



OM-193 696A September 2001

Effective with serial number :
153 421

Processes



Stick (SMAW) Welding

Description



Arc Welding Power Source

CE

Bluthunder 340/440



OWNER'S MANUAL



Visit our website at
www.MillerWelds.com

From Miller to You

Thank you and congratulations on choosing Miller. Now you can get the job done and get it done right. We know you don't have time to do it any other way.



That's why when Niels Miller first started building arc welders in 1929, he made sure his products offered long-lasting value and superior quality. Like you, his customers couldn't afford anything less. Miller products had to be more than the best they could be. They had to be the best you could buy.

Today, the people that build and sell Miller products continue the tradition. They're just as committed to providing equipment and service that meets the high standards of quality and value established in 1929.

This Owner's Manual is designed to help you get the most out of your Miller products. Please take time to read the Safety precautions. They will help you protect yourself against potential hazards on the worksite. We've made installation and operation quick and easy. With Miller you can count on years of reliable service with proper maintenance. And if for some reason the unit needs repair, there's a Troubleshooting section that will help you figure out what the problem is. The parts list will then help you to decide which exact part you may need to fix the problem.

Warranty and service information for your particular model are also provided.

Miller Electric manufactures a full line of welders and welding related equipment. For information on other quality Miller products, contact your local Miller distributor to receive the latest full line catalog or individual catalog sheets.



Working as hard as you do – every power source from Miller is backed by the most hassle-free warranty in the business.



TABLE OF CONTENTS

SECTION 1 – SAFETY PRECAUTIONS - READ BEFORE USING	1
1-1. Symbol Usage	1
1-2. Arc Welding Hazards	1
1-3. Additional Symbols for Installation, Operation, and Maintenance	3
1-4. Principal Safety Standards	3
1-5. EMF Information	4
SECTION 2 – INSTALLATION	5
2-1. Specifications	5
2-2. Duty Cycle and Overheating	5
2-3. Volt-Ampere Curves	6
2-4. Positioning Jumper Links	6
2-5. Electrical Service Guide	7
2-6. Selecting a Location and Connecting Input Power	7
SECTION 3 – OPERATION	8
3-1. Controls	8
SECTION 4 – MAINTENANCE AND TROUBLESHOOTING	9
4-1. Routine Maintenance	9
4-2. Troubleshooting	9
SECTION 5 – ELECTRICAL DIAGRAM	10
SECTION 6 – PARTS LIST	12
WARRANTY	

Declaration of Conformity

Manufacturer's Name: **MILLER Europe S.r.l.**

Manufacturer's Address: Via Privata Iseo, 6/E
20098 San Giuliano
Milanese, Italy

Declares that this product: **Bluthunder 340/440**

Conforms to the following Directives and Standards:

Directives

Electromagnetic Compatibility Directives: 89/336/EEC, 92/31/EEC
Compatibilità Elettromagnetica: (EMC) 89/336/CEE, 92/31/CEE

Low Voltage: 73/23/EEC
Direttiva bassa tensione: 73/23/CEE

Machinery Directives: 89/392/EEC
Direttiva Macchine: 89/392/CEE

And their amendments 91/368/EEC, 93/C 133/04, 93/68/EEC
Aggiornate dalle direttive 91/368/CEE, 93/C 133/04, 93/68/CEE

Standards

Electromagnetic compatibility (EMC) Product standard for arc welding equipment:
EN50199: August 1995
Norma sulla compatibilità elettromagnetica (EMC) dei prodotti per apparecchi di saldatura ad arco:
EN50199, agosto 1995

Safety Requirements for Arc Welding Equipment part 1: EN 60974-1, 1989
Prescrizioni di sicurezza per apparecchi di saldatura ad arco, Sezione 1: EN 60974-1, 1989

European Contact: Danilo Fedolfi, Managing Director
MILLER Europe S.r.l.
Via Privata Iseo, 6/E
20098 San Giuliano
Milanese, Italy

Telephone: 39(0)2-982901
Fax: 39(0)2-98290-203

SECTION 1 – SAFETY PRECAUTIONS - READ BEFORE USING

som_nd_4/98

1-1. Symbol Usage



Means Warning! Watch Out! There are possible hazards with this procedure! The possible hazards are shown in the adjoining symbols.

▲ Marks a special safety message.

☞ Means "Note"; not safety related.



This group of symbols means Warning! Watch Out! possible ELECTRIC SHOCK, MOVING PARTS, and HOT PARTS hazards. Consult symbols and related instructions below for necessary actions to avoid the hazards.

1-2. Arc Welding Hazards

▲ The symbols shown below are used throughout this manual to call attention to and identify possible hazards. When you see the symbol, watch out, and follow the related instructions to avoid the hazard. The safety information given below is only a summary of the more complete safety information found in the Safety Standards listed in Section 1-4. Read and follow all Safety Standards.

▲ Only qualified persons should install, operate, maintain, and repair this unit.

▲ During operation, keep everybody, especially children, away.



ELECTRIC SHOCK can kill.

Touching live electrical parts can cause fatal shocks or severe burns. The electrode and work circuit is electrically live whenever the output is on. The input power circuit and machine internal circuits are also

live when power is on. In semiautomatic or automatic wire welding, the wire, wire reel, drive roll housing, and all metal parts touching the welding wire are electrically live. Incorrectly installed or improperly grounded equipment is a hazard.

- Do not touch live electrical parts.
- Wear dry, hole-free insulating gloves and body protection.
- Insulate yourself from work and ground using dry insulating mats or covers big enough to prevent any physical contact with the work or ground.
- Do not use AC output in damp areas, if movement is confined, or if there is a danger of falling.
- Use AC output ONLY if required for the welding process.
- If AC output is required, use remote output control if present on unit.
- Disconnect input power or stop engine before installing or servicing this equipment. Lockout/tagout input power according to OSHA 29 CFR 1910.147 (see Safety Standards).
- Properly install and ground this equipment according to its Owner's Manual and national, state, and local codes.
- Always verify the supply ground – check and be sure that input power cord ground wire is properly connected to ground terminal in disconnect box or that cord plug is connected to a properly grounded receptacle outlet.
- When making input connections, attach proper grounding conductor first – double-check connections.
- Frequently inspect input power cord for damage or bare wiring – replace cord immediately if damaged – bare wiring can kill.
- Turn off all equipment when not in use.
- Do not use worn, damaged, undersized, or poorly spliced cables.
- Do not drape cables over your body.

- If earth grounding of the workpiece is required, ground it directly with a separate cable.
- Do not touch electrode if you are in contact with the work, ground, or another electrode from a different machine.
- Use only well-maintained equipment. Repair or replace damaged parts at once. Maintain unit according to manual.
- Wear a safety harness if working above floor level.
- Keep all panels and covers securely in place.
- Clamp work cable with good metal-to-metal contact to workpiece or worktable as near the weld as practical.
- Insulate work clamp when not connected to workpiece to prevent contact with any metal object.
- Do not connect more than one electrode or work cable to any single weld output terminal.

SIGNIFICANT DC VOLTAGE exists after removal of input power on inverters.

- Turn Off inverter, disconnect input power, and discharge input capacitors according to instructions in Maintenance Section before touching any parts.

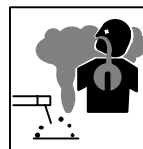

FUMES AND GASES can be hazardous.

Welding produces fumes and gases. Breathing these fumes and gases can be hazardous to your health.

- Keep your head out of the fumes. Do not breathe the fumes.
- If inside, ventilate the area and/or use exhaust at the arc to remove welding fumes and gases.
- If ventilation is poor, use an approved air-supplied respirator.
- Read the Material Safety Data Sheets (MSDSs) and the manufacturer's instructions for metals, consumables, coatings, cleaners, and degreasers.
- Work in a confined space only if it is well ventilated, or while wearing an air-supplied respirator. Always have a trained watch-person nearby. Welding fumes and gases can displace air and lower the oxygen level causing injury or death. Be sure the breathing air is safe.
- Do not weld in locations near degreasing, cleaning, or spraying operations. The heat and rays of the arc can react with vapors to form highly toxic and irritating gases.
- Do not weld on coated metals, such as galvanized, lead, or cadmium plated steel, unless the coating is removed from the weld area, the area is well ventilated, and if necessary, while wearing an air-supplied respirator. The coatings and any metals containing these elements can give off toxic fumes if welded.



ARC RAYS can burn eyes and skin.

Arc rays from the welding process produce intense visible and invisible (ultraviolet and infrared) rays that can burn eyes and skin. Sparks fly off from the weld.

- Wear a welding helmet fitted with a proper shade of filter to protect your face and eyes when welding or watching (see ANSI Z49.1 and Z87.1 listed in Safety Standards).
- Wear approved safety glasses with side shields under your helmet.
- Use protective screens or barriers to protect others from flash and glare; warn others not to watch the arc.
- Wear protective clothing made from durable, flame-resistant material (leather and wool) and foot protection.



WELDING can cause fire or explosion.

Welding on closed containers, such as tanks, drums, or pipes, can cause them to blow up. Sparks can fly off from the welding arc. The flying sparks, hot workpiece, and hot equipment can cause fires and burns. Accidental contact of electrode to metal objects can cause sparks, explosion, overheating, or fire. Check and be sure the area is safe before doing any welding.

- Protect yourself and others from flying sparks and hot metal.
- Do not weld where flying sparks can strike flammable material.
- Remove all flammables within 35 ft (10.7 m) of the welding arc. If this is not possible, tightly cover them with approved covers.
- Be alert that welding sparks and hot materials from welding can easily go through small cracks and openings to adjacent areas.
- Watch for fire, and keep a fire extinguisher nearby.
- Be aware that welding on a ceiling, floor, bulkhead, or partition can cause fire on the hidden side.
- Do not weld on closed containers such as tanks, drums, or pipes, unless they are properly prepared according to AWS F4.1 (see Safety Standards).
- Connect work cable to the work as close to the welding area as practical to prevent welding current from traveling long, possibly unknown paths and causing electric shock and fire hazards.
- Do not use welder to thaw frozen pipes.
- Remove stick electrode from holder or cut off welding wire at contact tip when not in use.
- Wear oil-free protective garments such as leather gloves, heavy shirt, cuffless trousers, high shoes, and a cap.
- Remove any combustibles, such as a butane lighter or matches, from your person before doing any welding.



FLYING METAL can injure eyes.

- Welding, chipping, wire brushing, and grinding cause sparks and flying metal. As welds cool, they can throw off slag.
- Wear approved safety glasses with side shields even under your welding helmet.



BUILDUP OF GAS can injure or kill.

- Shut off shielding gas supply when not in use.
- Always ventilate confined spaces or use approved air-supplied respirator.

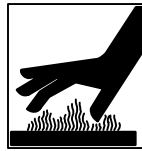

HOT PARTS can cause severe burns.

- Do not touch hot parts bare handed.
- Allow cooling period before working on gun or torch.

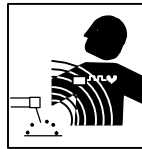

MAGNETIC FIELDS can affect pacemakers.

- Pacemaker wearers keep away.
- Wearers should consult their doctor before going near arc welding, gouging, or spot welding operations.

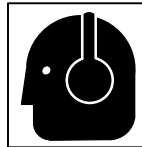

NOISE can damage hearing.

Noise from some processes or equipment can damage hearing.

- Wear approved ear protection if noise level is high.

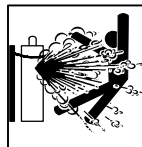

CYLINDERS can explode if damaged.

Shielding gas cylinders contain gas under high pressure. If damaged, a cylinder can explode. Since gas cylinders are normally part of the welding process, be sure to treat them carefully.

- Protect compressed gas cylinders from excessive heat, mechanical shocks, slag, open flames, sparks, and arcs.
- Install cylinders in an upright position by securing to a stationary support or cylinder rack to prevent falling or tipping.
- Keep cylinders away from any welding or other electrical circuits.
- Never drape a welding torch over a gas cylinder.
- Never allow a welding electrode to touch any cylinder.
- Never weld on a pressurized cylinder – explosion will result.
- Use only correct shielding gas cylinders, regulators, hoses, and fittings designed for the specific application; maintain them and associated parts in good condition.
- Turn face away from valve outlet when opening cylinder valve.
- Keep protective cap in place over valve except when cylinder is in use or connected for use.
- Read and follow instructions on compressed gas cylinders, associated equipment, and CGA publication P-1 listed in Safety Standards.

1-3. Additional Symbols For Installation, Operation, And Maintenance



FIRE OR EXPLOSION hazard.

- Do not install or place unit on, over, or near combustible surfaces.
- Do not install unit near flammables.
- Do not overload building wiring – be sure power supply system is properly sized, rated, and protected to handle this unit.



MOVING PARTS can cause injury.

- Keep away from moving parts such as fans.
- Keep all doors, panels, covers, and guards closed and securely in place.



FALLING UNIT can cause injury.

- Use lifting eye to lift unit only, NOT running gear, gas cylinders, or any other accessories.
- Use equipment of adequate capacity to lift and support unit.
- If using lift forks to move unit, be sure forks are long enough to extend beyond opposite side of unit.



OVERUSE can cause OVERHEATING

- Allow cooling period; follow rated duty cycle.
- Reduce current or reduce duty cycle before starting to weld again.
- Do not block or filter airflow to unit.



STATIC (ESD) can damage PC boards.

- Put on grounded wrist strap BEFORE handling boards or parts.
- Use proper static-proof bags and boxes to store, move, or ship PC boards.



MOVING PARTS can cause injury.

- Keep away from moving parts.
- Keep away from pinch points such as drive rolls.



WELDING WIRE can cause injury.

- Do not press gun trigger until instructed to do so.
- Do not point gun toward any part of the body, other people, or any metal when threading welding wire.

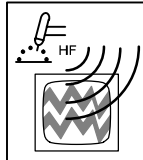

H.F. RADIATION can cause interference.

- High-frequency (H.F.) can interfere with radio navigation, safety services, computers, and communications equipment.
- Have only qualified persons familiar with electronic equipment perform this installation.
- The user is responsible for having a qualified electrician promptly correct any interference problem resulting from the installation.
- If notified by the FCC about interference, stop using the equipment at once.
- Have the installation regularly checked and maintained.
- Keep high-frequency source doors and panels tightly shut, keep spark gaps at correct setting, and use grounding and shielding to minimize the possibility of interference.



ARC WELDING can cause interference.

- Electromagnetic energy can interfere with sensitive electronic equipment such as computers and computer-driven equipment such as robots.
- Be sure all equipment in the welding area is electromagnetically compatible.
- To reduce possible interference, keep weld cables as short as possible, close together, and down low, such as on the floor.
- Locate welding operation 100 meters from any sensitive electronic equipment.
- Be sure this welding machine is installed and grounded according to this manual.
- If interference still occurs, the user must take extra measures such as moving the welding machine, using shielded cables, using line filters, or shielding the work area.

1-4. Principal Safety Standards

Safety in Welding and Cutting, ANSI Standard Z49.1, from American Welding Society, 550 N.W. LeJeune Rd, Miami FL 33126

Safety and Health Standards, OSHA 29 CFR 1910, from Superintendent of Documents, U.S. Government Printing Office, Washington, D.C. 20402.

Recommended Safe Practices for the Preparation for Welding and Cutting of Containers That Have Held Hazardous Substances, American Welding Society Standard AWS F4.1, from American Welding Society, 550 N.W. LeJeune Rd, Miami, FL 33126

National Electrical Code, NFPA Standard 70, from National Fire Protection Association, Batterymarch Park, Quincy, MA 02269.

Safe Handling of Compressed Gases in Cylinders, CGA Pamphlet P-1, from Compressed Gas Association, 1235 Jefferson Davis Highway, Suite 501, Arlington, VA 22202.

Code for Safety in Welding and Cutting, CSA Standard W117.2, from Canadian Standards Association, Standards Sales, 178 Rexdale Boulevard, Rexdale, Ontario, Canada M9W 1R3.

Safe Practices For Occupation And Educational Eye And Face Protection, ANSI Standard Z87.1, from American National Standards Institute, 1430 Broadway, New York, NY 10018.

Cutting And Welding Processes, NFPA Standard 51B, from National Fire Protection Association, Batterymarch Park, Quincy, MA 02269.

1-5. EMF Information

Considerations About Welding And The Effects Of Low Frequency Electric And Magnetic Fields

Welding current, as it flows through welding cables, will cause electromagnetic fields. There has been and still is some concern about such fields. However, after examining more than 500 studies spanning 17 years of research, a special blue ribbon committee of the National Research Council concluded that: "The body of evidence, in the committee's judgment, has not demonstrated that exposure to power-frequency electric and magnetic fields is a human-health hazard." However, studies are still going forth and evidence continues to be examined. Until the final conclusions of the research are reached, you may wish to minimize your exposure to electromagnetic fields when welding or cutting.

To reduce magnetic fields in the workplace, use the following procedures:

1. Keep cables close together by twisting or taping them.
2. Arrange cables to one side and away from the operator.
3. Do not coil or drape cables around your body.
4. Keep welding power source and cables as far away from operator as practical.
5. Connect work clamp to workpiece as close to the weld as possible.

About Pacemakers:

Pacemaker wearers consult your doctor first. If cleared by your doctor, then following the above procedures is recommended.



SECTION 2 – INSTALLATION

2-1. Specifications

Model	Rated Output				Max. Open Circuit Voltage	Rated Input Amperage at Rated Output				Dimension (mm)	Weight (kg)
	100%	60%	45%	35%		230 V	380 V	400 V	520 V		
340	190 A 27.6 V	245 A 29.8 V	--	320 A 32.8 V	68	55 A	32 A	32 A	23 A	510 x 650 x 1010	105
440	290 A 31.6 V	375 A 35 V	420 A 36.8 V	--	78	80 A	47 A	47 A	34 A	600 x 730 x 1150	175

* While idling

2-2. Duty Cycle and Overheating

Duty Cycle is percentage of 10 minutes that unit can weld at rated load without overheating.

▲ Exceeding duty cycle can damage unit and void warranty.

Rated Output

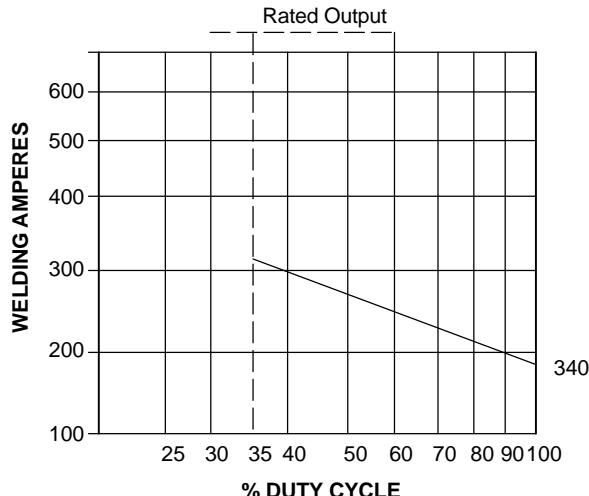

Rated Output

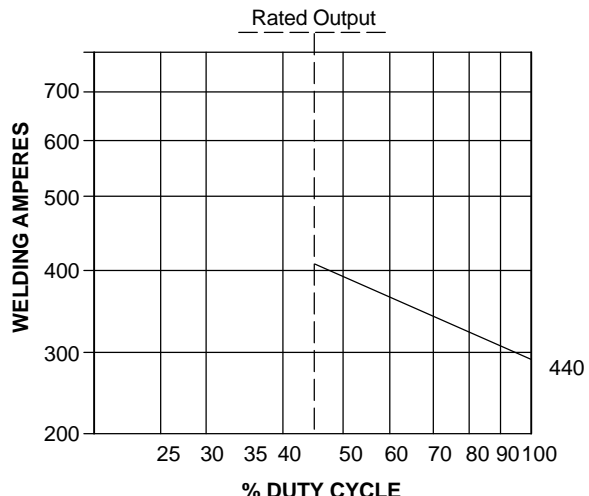

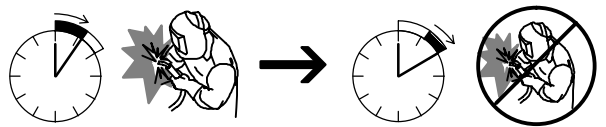

3.5 Minutes Welding 6.5 Minutes Resting

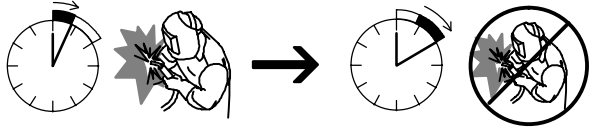

4.5 Minutes Welding 5.5 Minutes Resting

Overheating

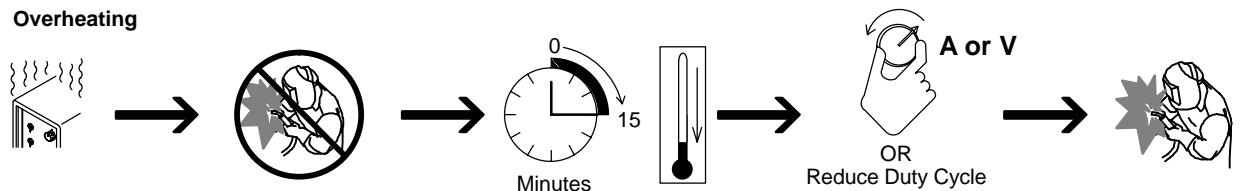

Minutes OR Reduce Duty Cycle

2-3. Volt-Ampere Curves

The volt-ampere curves show the normal minimum and maximum voltage and amperage output capabilities of the unit.

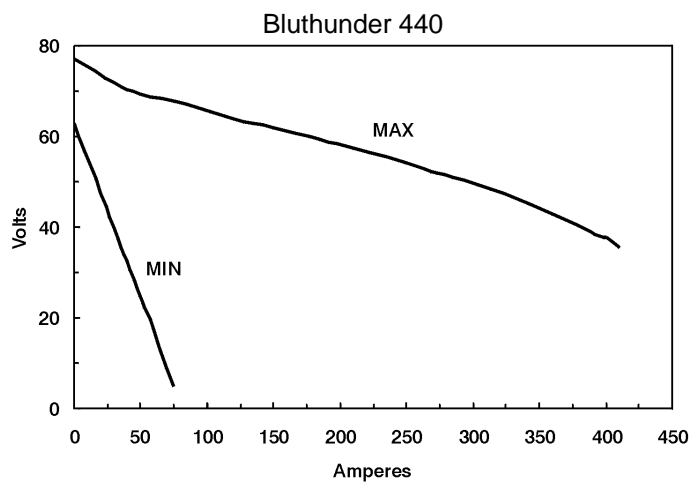
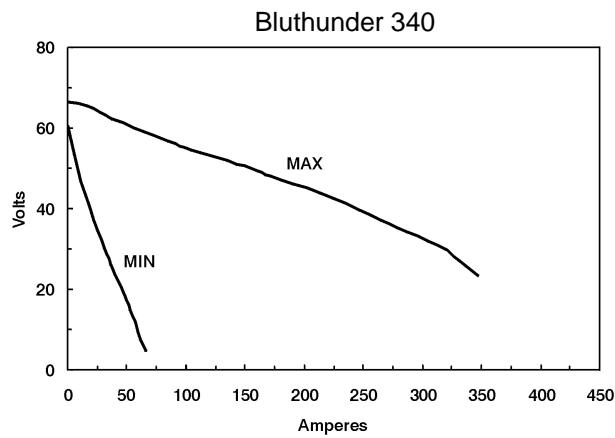

2-4. Positioning Jumper Links

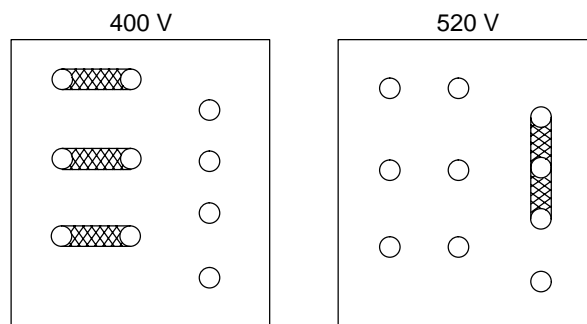

Check input voltage available at site.

1 Jumper Links Access

Remove side panel.

2 Jumper Link Label

Check label – only one is on unit.

3 Input Voltage Jumper Links

Move jumper links to match input voltage.

Close and secure side panel.

2-5. Electrical Service Guide

	340			440		
Input Voltage	230	400	520	230	400	520
Input Amperes at Rated Output	55	32	25	79	46	25
Max Recommended Standard Fuse or Circuit Breaker Rating in Amperes	55	32	25	79	46	25
** Input Conductor Size in mm²	6	6	6	6	6	6
** Grounding Conductor Size in mm²	6	6	6	6	6	6

** Power cord supplied with the unit is sized for 230V operation. Larger power cord may be required for cable lengths greater than 3 meters. Consult national and local regulations.

2-6. Selecting a Location and Connecting Input Power



Have only qualified persons make this installation.

1 Rating Label

Supply correct input power.

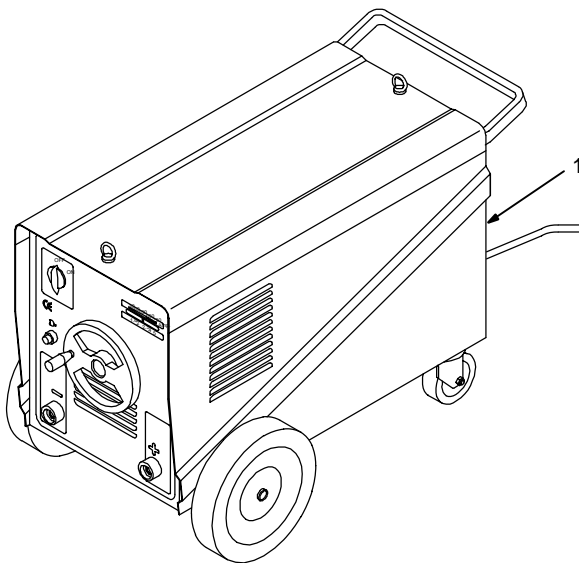
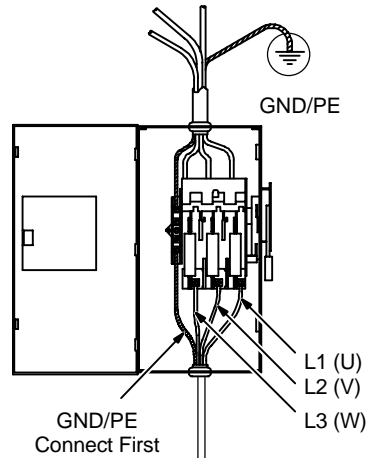
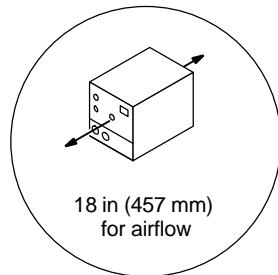

ST-801 721

SECTION 3 – OPERATION

3-1. Controls



- 1 Range
- 2 Output Amperage Control
- 3 + Positive Weld Terminal
- 4 - Negative Weld Terminal
- 5 Power On Pilot Light
- 6 Power Switch

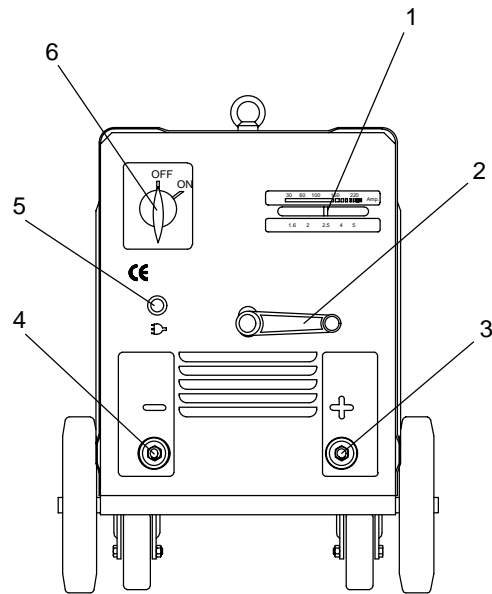
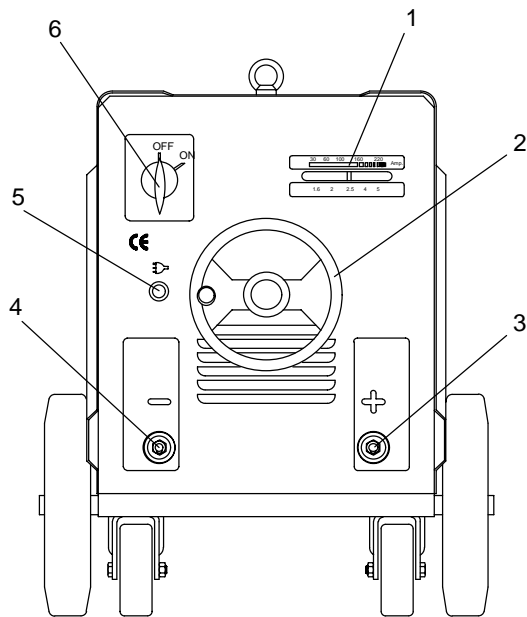

SECTION 4 – MAINTENANCE AND TROUBLESHOOTING

4-1. Routine Maintenance

			▲ Disconnect power before maintaining.
--	--	--	--

	3 Months	<p>Replace unreadable labels. </p> <p>Repair or replace cracked weld cable. </p>	
		<p>Clean and tighten weld terminals. </p>	
	6 Months	<p>Blow out or vacuum inside. During heavy service clean monthly. OR </p>	

4-2. Troubleshooting

--	--	--	--	--	--

Trouble	Remedy
No weld output; fan does not run.	Be sure line disconnect switch is in On position.
	Check and replace line fuses if open. Reset breakers if necessary.
Fan does not run; weld output okay.	Be sure nothing is blocking movement of fan. If fan does not run freely, replace fan motor.
Erratic weld current.	Clean and tighten all weld cable connections.
Erratic arc with excessive spatter.	Use dry, properly stored electrodes.
	Shorten arc length.
	Reduce amperage setting.
Electrode freezing to work.	Increase amperage setting.
	Increase arc length.
	Use dry, properly stored electrodes.

SECTION 5 – ELECTRICAL DIAGRAM

5-1. Bluthunder 340/440 230V - 400V

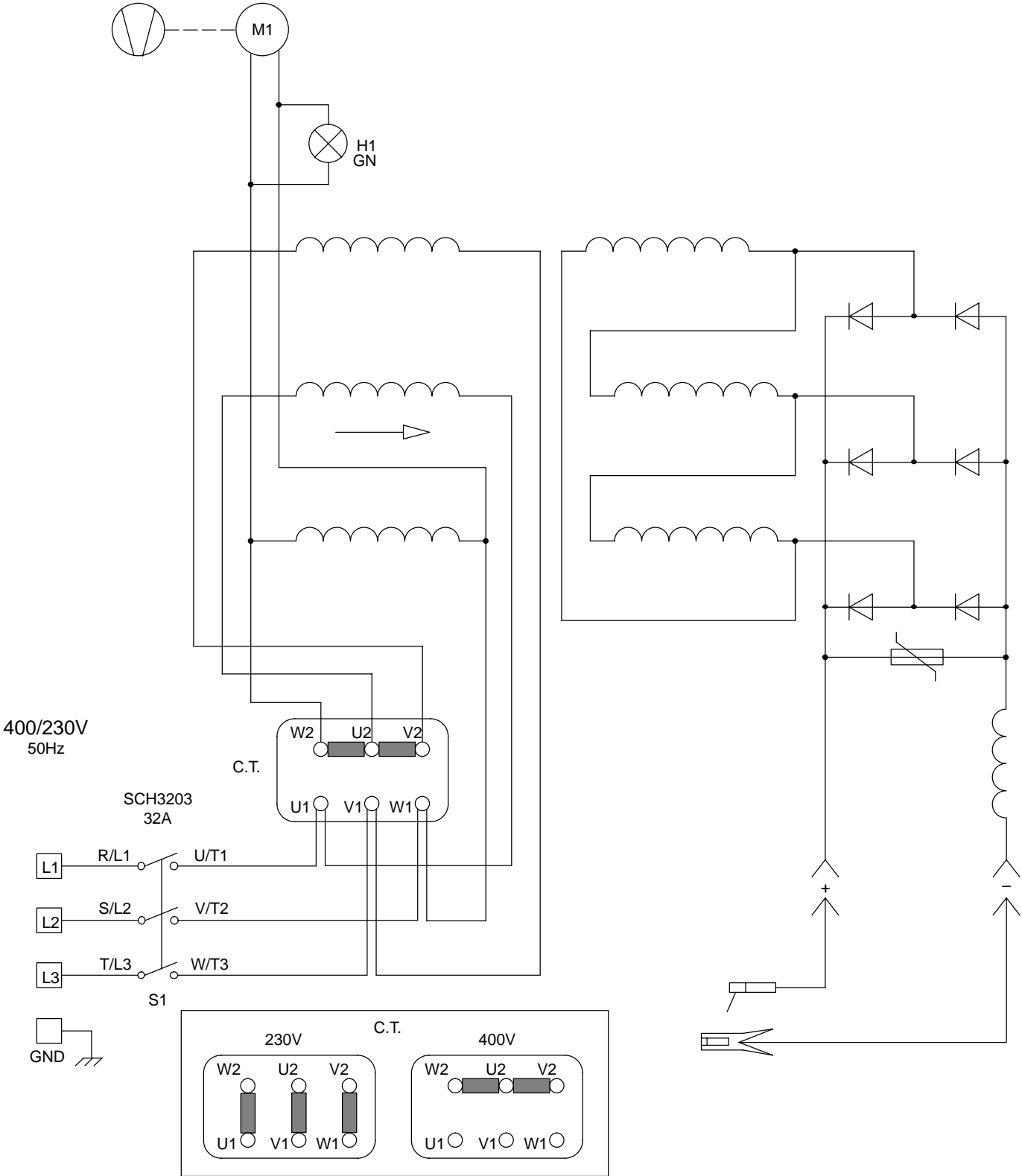

5-2. Bluthunder 340/440 400V - 520V

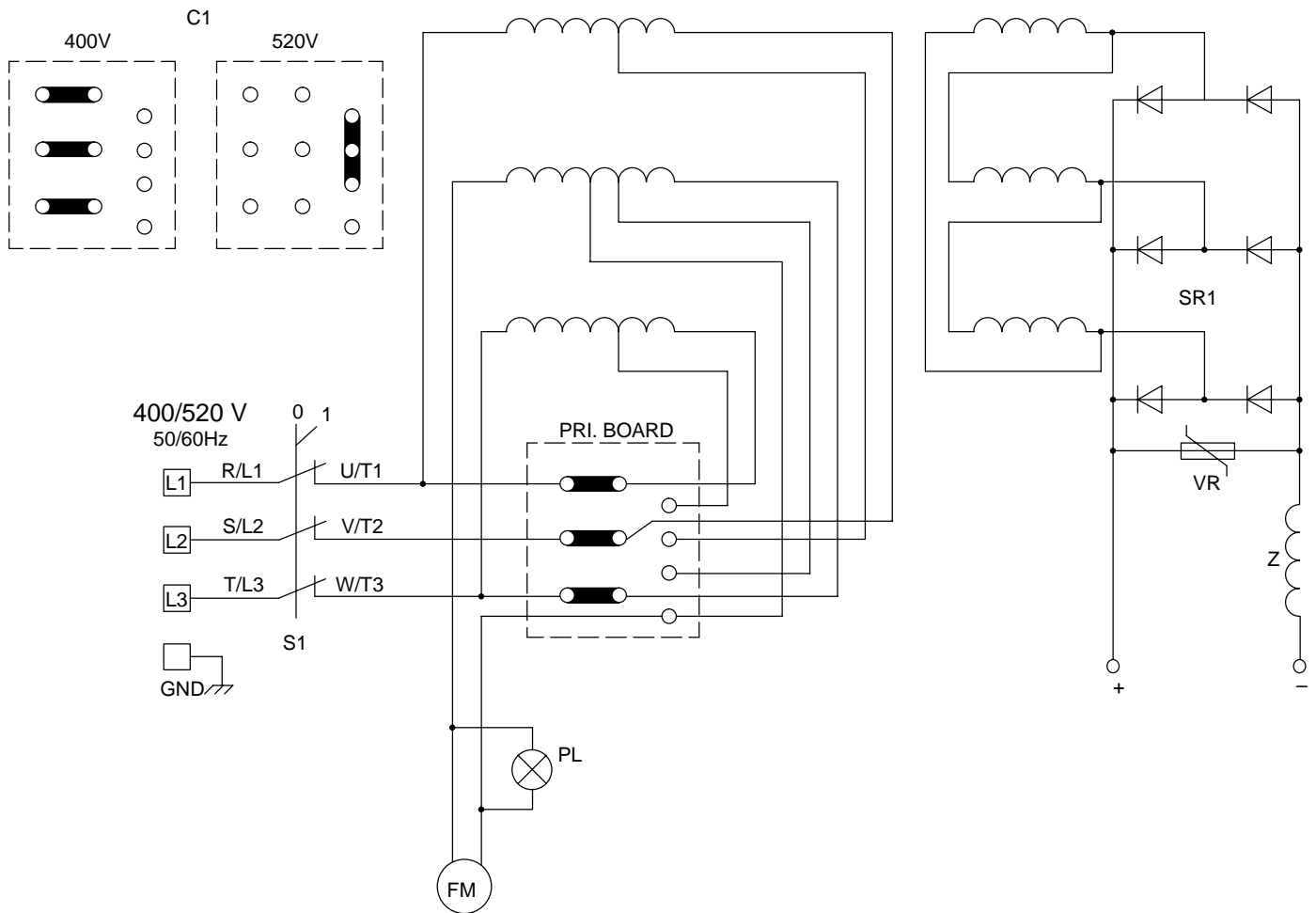

SECTION 6 – PARTS LIST

6-1. Main Assembly (340)

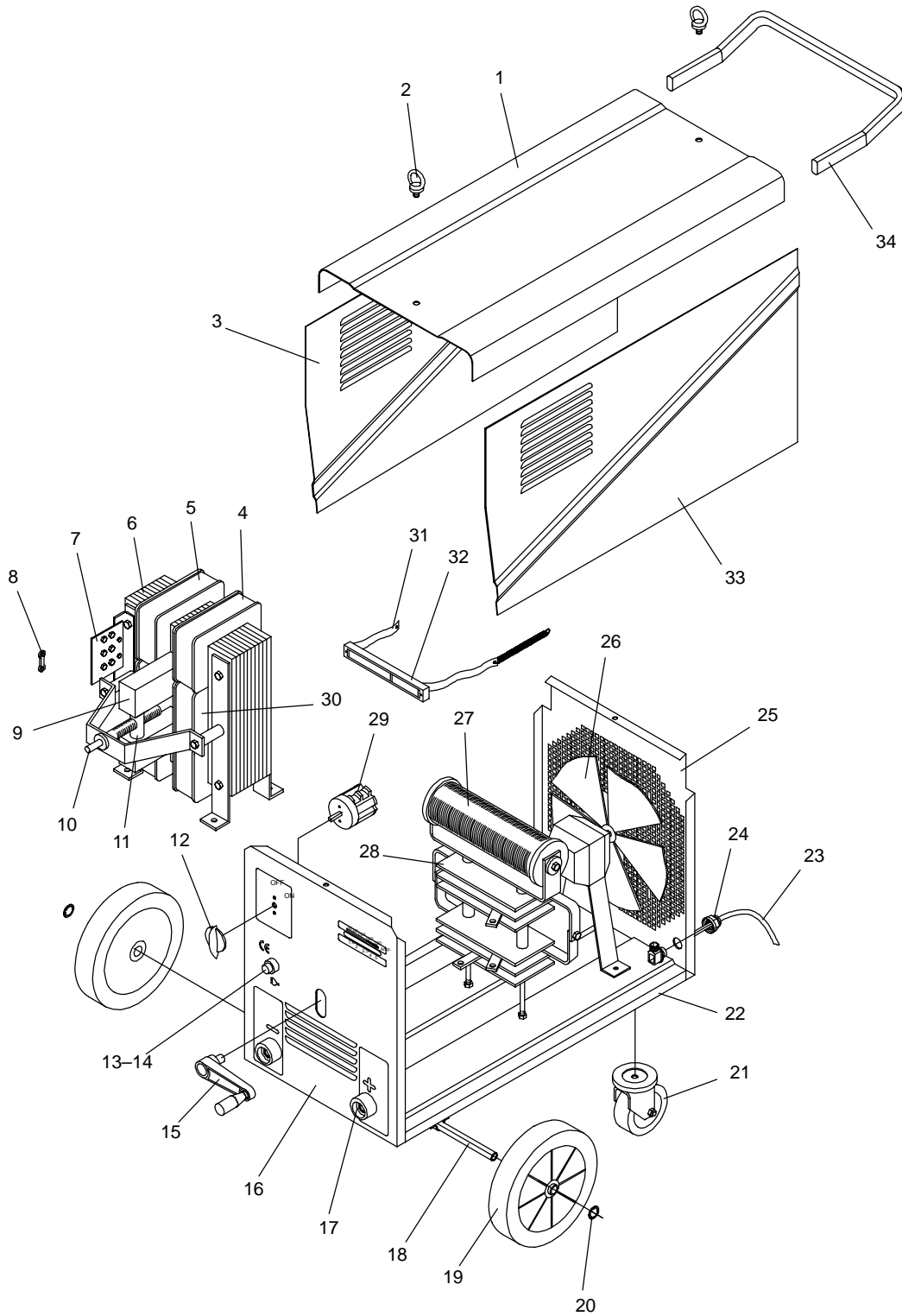

Item	Dia Ref.	Code	Dwg	Qty.
1		156121009	ZL.0.0.6	1
2		156011019	UZ.0.0.14	2
3		156122027	ZL.0.0.4	1
4	SEC. WIND.	057150063	UZ.1.2	3
5	PRIM. WIND.	057015099	UZ.3.1	3
6		058021132	UZ.3	
7	PRI. BOARD	756069030	ZI.0.0.10	1
8		556070015	VA.0.0.15	6
9		056059255	UZ.1.1.1	2
10		556019042	UZ.0.0.16	1
11		057029003	UZ.1.1	1
12		056020037	UZ.0.0.15	1
13	PL	056072064	UZ.0.0.4	1
14		056072065	UZ.0.0.5	1
15		056002010	UZ.0.0.6	1
16		156118042	ZL.0.0.12	1
17		056076152	DD.0.0.7	2
18		156012079	UZ.0.0.12	1
19		056054056	UZ.0.0.11	2
20		156023157	UZ.0.0.21	2
21		056054058	UZ.0.0.13	2
22		156118007	UZ.0.0.8	1
23		057014053	UZ.0.1	1
24		656089026	VA.0.0.1	1
25		156118020	UZ.0.0.20	1
26	FM. 230 V 50/60 Hz	057035008	UZ.0.2	1
27	Z	057098004	UZ.0.3	1
28	SR1	056050127	UZ.0.0.2	1
29	S1	056067211	UZ.0.0.18	1
31		656062010	ZL.0.0.9	1
32		176109019	UZ.0.0.22	1
33		156122028	ZL.0.0.5	1
34		156002019	UZ.0.0.10	1

Machine 400/520 V

Item	Dia Ref.	Code	Dwg	Qty.
4	PRI. WIND. 400/520	057015077	UZ.2.2	2
6	TI 400/520	058021097	UZ.2	1
7	PRI. BOARD	756069027	UZ.0.0.19	1
30	PRI. CENTER COIL	057015076	UZ.2.1	1

6-2. Main Assembly (440)

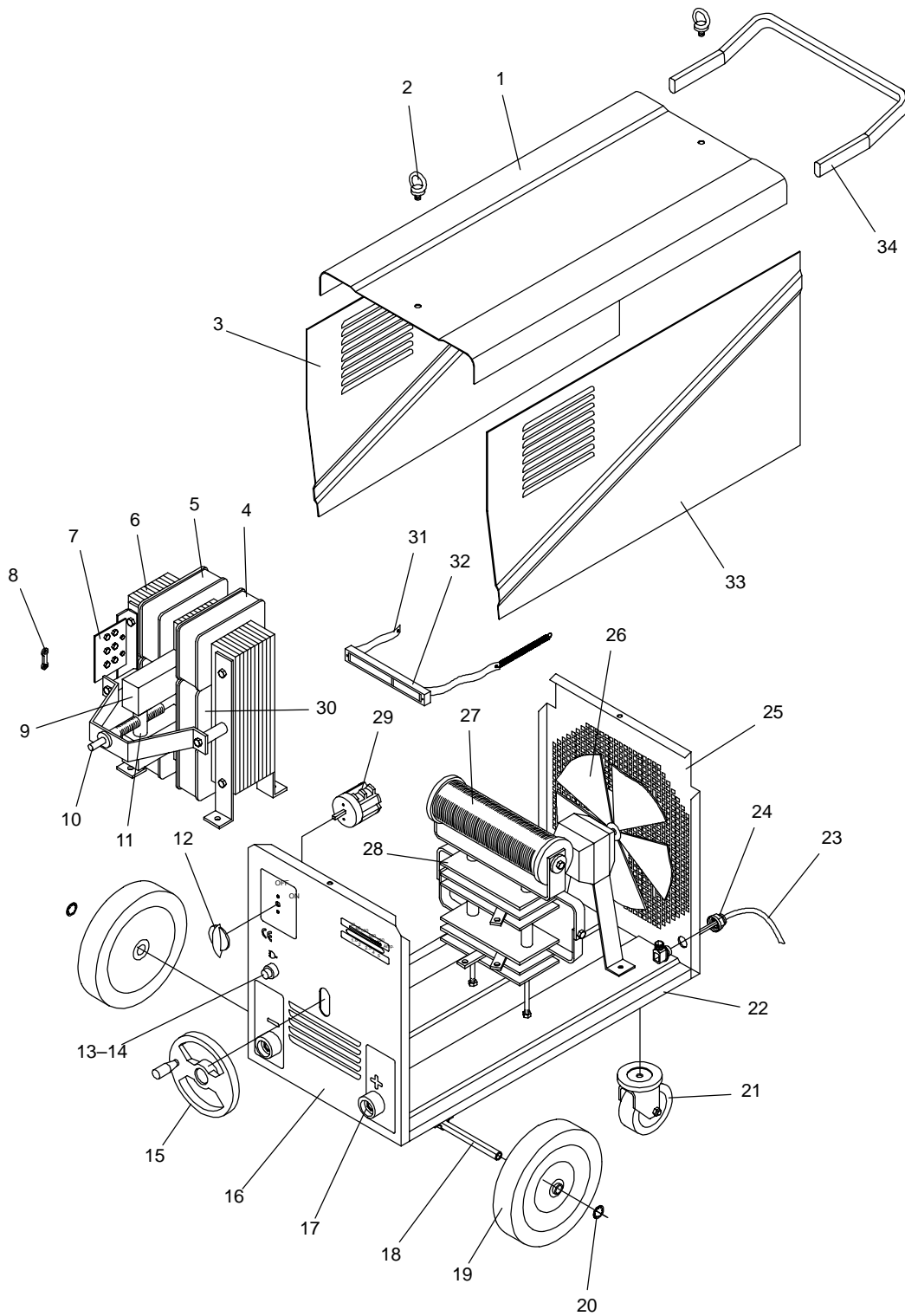

Item	Dia Ref.	Code	Dwg	Qty.
1		156121010	VA.0.0.20	1
2		156011019	UZ.0.0.14	2
3		156122032	VA.0.0.19	1
4	PRI. WIND. 230/400	057015091	VA.3.1	3
5	SEC. WIND	057015065	VA.1.2	3
6	T1 230/400 50/60 Hz	058021114	VA.3	1
7	PRI. BOARD	756069030	ZL.0.0.10	1
8		556070015	VA.0.0.15	6
9		056059256	VA.1.1.1	2
10		556019043	VA.0.0.12	1
11		057029004	VA.1.1	1
12		056020037	UZ.0.0.15	1
13	PL	056072064	UZ.0.0.4	1
14		056072065	UZ.0.0.5	1
15		056002036	VA.0.0.4	1
16		156118006	VA.0.0.5	1
17		056076152	DD.0.0.7	2
18		156012080	VA.0.0.10	1
19		056054057	VA.0.0.9	2
20		156023156	VA.0.0.17	2
21		056054059	VA.0.0.11	2
22		156118008	VA.0.0.6	1
23		057014054	VA.0.1	1
24		658089026	VA.0.0.1	1
25		156118019	VA.0.0.16	1
26	FM. 230 V 50/60 Hz	057035009	VA.0.2	1
27	Z	057098005	VA.0.3	1
28	SR1	056050128	VA.0.0.2	1
29	S1	056067210	VA.0.0.13	1
31		656062010	ZL.0.0.9	1
32		176109020	VA.0.0.18	1
33		156122031	VA.0.0.18	1
34		156002020	VA.0.0.8	1

Machine 400/520 V

Item	Dia Ref.	Code	Dwg	Qty.
4	PRI. COIL	058015080	VA.2.2	2
6	T1 400/520	058021098	VA.2	1
7	PRI. BOARD	157069026	VA.0.0.14	1
30	PRI. CENTER COIL	057015079	VA.2.1	1

TRUE BLUE® WARRANTY

Effective January 1, 2000

This limited warranty supersedes all previous Miller warranties and is exclusive with no other guarantees or warranties expressed or implied.

LIMITED WARRANTY – Subject to the terms and conditions below, Miller Electric Mfg. Co., Appleton, Wisconsin, warrants to its original retail purchaser that new Miller equipment sold after the effective date of this limited warranty is free of defects in material and workmanship at the time it is shipped by Miller. THIS WARRANTY IS EXPRESSLY IN LIEU OF ALL OTHER WARRANTIES, EXPRESS OR IMPLIED, INCLUDING THE WARRANTIES OF MERCHANTABILITY AND FITNESS.

Within the warranty periods listed below, Miller will repair or replace any warranted parts or components that fail due to such defects in material or workmanship. Miller must be notified in writing within thirty (30) days of such defect or failure, at which time Miller will provide instructions on the warranty claim procedures to be followed.

Miller shall honor warranty claims on warranted equipment listed below in the event of such a failure within the warranty time periods. All warranty time periods start on the date that the equipment was delivered to the original retail purchaser, or one year after the equipment is sent to a North American distributor or eighteen months after the equipment is sent to an International distributor.

1. 5 Years Parts – 3 Years Labor
 - * Original main power rectifiers
 - * Inverters (input and output rectifiers only)
2. 3 Years — Parts and Labor
 - * Transformer/Rectifier Power Sources
 - * Plasma Arc Cutting Power Sources
 - * Semi-Automatic and Automatic Wire Feeders
 - * Inverter Power Supplies
 - * Intelligent
 - * Engine Driven Welding Generators
(NOTE: Engines are warranted separately by the engine manufacturer.)
3. 1 Year — Parts and Labor
 - * DS-2 Feeder
 - * Motor Driven Guns (w/exception of Spoolmate 185 and Spoolmate 250)
 - * Process Controllers
 - * Positioners and Controllers
 - * Automatic Motion Devices
 - * RFCS Foot Controls
 - * IHPS Power Sources
 - * Water Coolant Systems
 - * HF Units
 - * Grids
 - * Maxstar 140
 - * Spot Welders
 - * Load Banks
 - * Miller Cyclomatic Equipment
 - * Running Gear/Trailers
 - * Plasma Cutting Torches (except APT & SAF Models)
 - * Field Options
(NOTE: Field options are covered under True Blue® for the remaining warranty period of the product they are installed in, or for a minimum of one year — whichever is greater.)
4. 6 Months — Batteries
5. 90 Days — Parts
 - * MIG Guns/TIG Torches
 - * Induction heating coils and blankets

- * APT, ZIPCUT & PLAZCUT Model Plasma Cutting Torches
- * Remote Controls
- * Accessory Kits
- * Replacement Parts (No labor)
- * Spoolmate 185 and Spoolmate 250
- * Canvas covers

Miller's True Blue® Limited Warranty shall not apply to:

1. Items furnished by Miller, but manufactured by others, such as engines or trade accessories. These items are covered by the manufacturer's warranty, if any.
2. Equipment that has been modified by any party other than Miller, or equipment that has been improperly installed, improperly operated or misused based upon industry standards, or equipment which has not had reasonable and necessary maintenance, or equipment which has been used for operation outside of the specifications for the equipment.
3. **Consumable components; such as contact tips, cutting nozzles, contactors, brushes, slip rings, relays or parts that fail due to normal wear.**

MILLER PRODUCTS ARE INTENDED FOR PURCHASE AND USE BY COMMERCIAL/INDUSTRIAL USERS AND PERSONS TRAINED AND EXPERIENCED IN THE USE AND MAINTENANCE OF WELDING EQUIPMENT.

In the event of a warranty claim covered by this warranty, the exclusive remedies shall be, at Miller's option: (1) repair; or (2) replacement; or, where authorized in writing by Miller in appropriate cases, (3) the reasonable cost of repair or replacement at an authorized Miller service station; or (4) payment of or credit for the purchase price (less reasonable depreciation based upon actual use) upon return of the goods at customer's risk and expense. Miller's option of repair or replacement will be F.O.B., Factory at Appleton, Wisconsin, or F.O.B. at a Miller authorized service facility as determined by Miller. Therefore no compensation or reimbursement for transportation costs of any kind will be allowed.

TO THE EXTENT PERMITTED BY LAW, THE REMEDIES PROVIDED HEREIN ARE THE SOLE AND EXCLUSIVE REMEDIES. IN NO EVENT SHALL MILLER BE LIABLE FOR DIRECT, INDIRECT, SPECIAL, INCIDENTAL OR CONSEQUENTIAL DAMAGES (INCLUDING LOSS OF PROFIT), WHETHER BASED ON CONTRACT, TORT OR ANY OTHER LEGAL THEORY.

ANY EXPRESS WARRANTY NOT PROVIDED HEREIN AND ANY IMPLIED WARRANTY, GUARANTY OR REPRESENTATION AS TO PERFORMANCE, AND ANY REMEDY FOR BREACH OF CONTRACT TORT OR ANY OTHER LEGAL THEORY WHICH, BUT FOR THIS PROVISION, MIGHT ARISE BY IMPLICATION, OPERATION OF LAW, CUSTOM OF TRADE OR COURSE OF DEALING, INCLUDING ANY IMPLIED WARRANTY OF MERCHANTABILITY OR FITNESS FOR PARTICULAR PURPOSE, WITH RESPECT TO ANY AND ALL EQUIPMENT FURNISHED BY MILLER IS EXCLUDED AND DISCLAIMED BY MILLER.

Some states in the U.S.A. do not allow limitations of how long an implied warranty lasts, or the exclusion of incidental, indirect, special or consequential damages, so the above limitation or exclusion may not apply to you. This warranty provides specific legal rights, and other rights may be available, but may vary from state to state.

In Canada, legislation in some provinces provides for certain additional warranties or remedies other than as stated herein, and to the extent that they may not be waived, the limitations and exclusions set out above may not apply. This Limited Warranty provides specific legal rights, and other rights may be available, but may vary from province to province.



Owner's Record

Please complete and retain with your personal records.

Model Name

Serial/Style Number

Purchase Date

(Date which equipment was delivered to original customer.)

Distributor

Address

Miller Electric Mfg. Co.

An Illinois Tool Works Company
1635 West Spencer Street
Appleton, WI 54914 USA

International Headquarters—USA

Phone: 414-735-4505
USA & Canada FAX: 920-735-4134
International FAX: 920-735-4125

European Headquarters – United Kingdom

Phone: 44 (0) 1204-593493
FAX: 44 (0) 1204-598066

Miller Europe

Italy
Phone: 39 (0) 2982901

