

User guide

MAGNAVOX
SMART. VERY SMART.

MCR140 CLOCK RADIO



Thank you for choosing Magnavox
NEED HELP FAST?

Read your Quick Use Guide and/or Owner's Manual first for quick tips that make using your Magnavox product more enjoyable.

If you have read your instructions and still need assistance, you may access our online help at

www.usasupport.Magnavox.com
or call

1-800-705-2000

while with your product
(and Model / serial number)



MAGNAVOX
Philips Consumer Electronics North America
Knoxville, Tennessee 37914-1810, U.S.A.

Meet Philips at the Internet
<http://www.philips.com>

MCR140

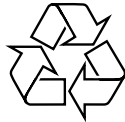

Printed in China

PDCC/JH - 523

SAFETY

Know these *safety* symbols



This "bolt of lightning" indicates uninsulated material within your unit which may cause an electrical shock. For the safety of everyone in your household, please do not remove product covering.



The "exclamation point" calls attention to features for which you should read the enclosed literature closely to prevent operating and maintenance problems.

WARNING: WARNING: TO PREVENT FIRE OR SHOCK HAZARD, DO NOT EXPOSE THIS EQUIPMENT TO RAIN OR MOISTURE.

CAUTION: To prevent electric shock, match wide blade of plug to wide slot, and fully insert.

IMPORTANT SAFETY INSTRUCTIONS

1. Read these instructions.
2. Keep these instructions.
3. Heed all warnings.
4. Follow all instructions.
5. Do not use this apparatus near water.
6. Clean only with dry cloth.
7. Do not block any ventilation openings. Install in accordance with the manufacturer's instructions.
8. Do not install near any heat sources such as radiators, heat registers, stoves, or other apparatus (including amplifiers) that produce heat.
9. Do not defeat the safety purpose of the polarized or grounding-type plug. A polarized plug has two blades with one wider than the other. A grounding type plug has two blades and a third grounding prong. The wide blade or the third prong are provided for your safety. If the provided plug does not fit into your outlet, consult an electrician for replacement of the obsolete outlet.
10. Protect the power cord from being walked on or pinched, particularly at plugs, convenience receptacles, and the point where they exit from the apparatus.
11. Only use attachments/accessories specified by the manufacturer.
12.  Use only with the cart, stand, tripod, bracket, or table specified by the manufacturer or sold with the apparatus. When a cart is used, use caution when moving the cart/apparatus combination to avoid injury from tip-over.
13. Unplug this apparatus during lightning storms or when unused for long periods of time.
14. Refer all servicing to qualified service personnel. Servicing is required when the apparatus has been damaged in any way, such as power-supply cord or plug is damaged, liquid has been spilled or objects have fallen into the apparatus, the apparatus has been exposed to rain or moisture, does not operate normally, or has been dropped.
15. Battery usage **CAUTION** – To prevent battery leakage which may result in bodily injury, property damage, or damage to the unit:
 - Install **all** batteries correctly, + and – as marked on the unit.
 - Do not mix batteries (**old** and **new** or **carbon** and **alkaline**, etc.).
 - Remove batteries when the unit is not used for a long time.
16. Apparatus shall not be exposed to dripping or splashing.
17. Do not place any sources of danger on the apparatus (i.e. liquid filled objects, lighted candles).
18. This product may contain lead and mercury. Disposal of these material may be regulated due to environmental considerations. **For disposal or recycling information, please contact your local authorities or the Electronic Industries Alliance : www.eiae.org.**

EL 6475-E005: 04/01

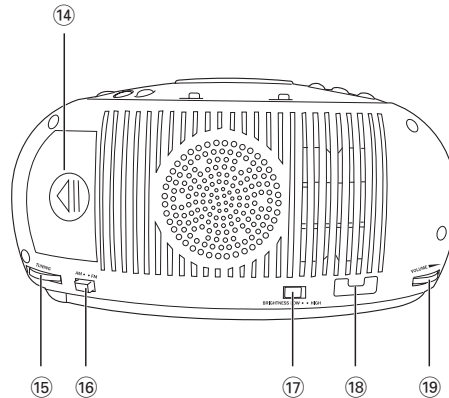
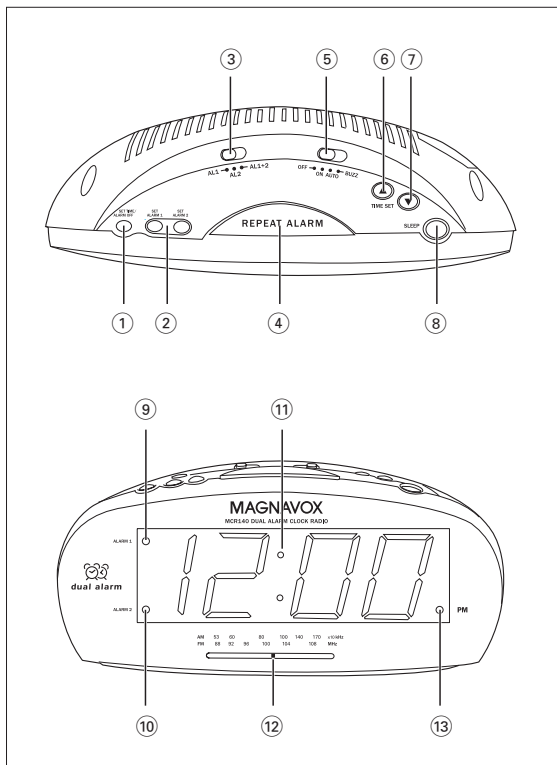

English

CONTROLS

Top View (see fig. [1])

- ① **SET TIME /ALARM OFF**
 - sets the clock time
 - stops the active alarm for 24 hours
 - switches off the radio sleep function
- ② **SET ALARM 1 / SET ALARM 2** - sets the alarm time for alarm 1 / alarm 2
- ③ **AL1/ AL2 /AL1+2** - selects which alarm(s) you want to set alarm time on
- ④ **REPEAT ALARM** - switches off the active alarm for a 7-8 minutes period
- ⑤ **OFF/ ON/ AUTO/ BUZZ**
 - OFF:** switches off the radio/alarm
 - ON:** switches on the radio
 - AUTO:** activates the radio for alarm
 - BUZZ:** activates the buzzer for alarm
- ⑥ **TIME SET ▲** - to adjust time fast forward
- ⑦ **TIME SET ▼** - to adjust time back
- ⑧ **SLEEP**
 - activates the radio for sleep function
 - adjusts the sleep period

Front View (see fig. [2])

- ⑨ **ALARM 1** indicator - lights up when alarm 1 is activated.
- ⑩ **ALARM 2** indicator - lights up when alarm 2 is activated.
- ⑪ **DISPLAY** - shows the clock/alarm time and status of the setting
- ⑫ **Frequency** pointer - shows the radio frequency of your selected waveband
- ⑬ **PM** indicator -lights up when time is PM.

CLOCK MEMORY BACKUP

The clock memory backup allows your alarm and clock time settings to be stored for up to a day when there is a power interruption e.g. power failure. The complete clock radio and display illumination will be switched off. As soon as the power supply returns, the display will indicate the correct time.

- 1 Remove the battery door to insert a **9 volts 6F22** type battery (not included) for backup.
- 2 Replace the battery door.

NOTE: If no backup battery is installed or the power interruption is prolonged, you will need to set the clock and alarm times again.

Batteries contain chemical substances so they should be disposed of properly.

Standby power consumption 2W

RADIO

You can use this set solely as a radio!

- 1 Adjust **OFF/ ON/ AUTO/ BUZZ** to **ON** to switch on the radio.
- 2 Select your waveband by adjusting the **FM/AM** switch.
- 3 Adjust **TUNING** to tune to your desired station.
- 4 Turn the **VOLUME** control to adjust the volume level.
- 5 Adjust **OFF/ ON/ AUTO/ BUZZ** to **OFF** to switch off the radio.

To improve reception:

- FM:** use the antenna built in the power cord. Adjust the position of the power cord for optimum reception.
- AM:** uses a built-in antenna inside the set. Direct the antenna by adjusting the position of your set.

Back View (see fig. [3])

- ⑭ **Battery door** - opens to store a **9 volts 6F22** battery (not included) for clock memory backup.
- ⑮ **TUNING** - tunes to radio stations
- ⑯ **FM/AM** - selects FM/AM waveband
- ⑰ **BRIGHTNESS (High or Low)** -selects display brightness
- ⑱ **Power cord** - for power supply and to improve FM reception
- ⑲ **VOLUME** - adjusts the sound level

INSTALLATION

POWER SUPPLY

- 1 Check if the power supply, as shown on the **type plate located on the bottom of the set**, corresponds to your local power supply. If it does not, consult your dealer or service center.
- 2 Connect the power cord to the wall outlet.
- 3 **To disconnect the set from the power supply completely, remove the plug from the wall outlet.**

SELECTING DISPLAY BRIGHTNESS

This set allows you to choose high or low brightness of display.

- Adjust **BRIGHTNESS** switch (located on the rear of the set) to **HIGH** or **LOW** position.

SETTING THE CLOCK TIME

The time is displayed using the 12-hour clock with PM indicator (PM off = AM).

- 1 Hold down **SET TIME/ALARM OFF**.
- 2 Press **TIME SET ▲** or **▼** repeatedly, or hold down **TIME SET ▲** or **▼** to adjust minute and/or hour.
 - **TIME SET ▲** : to adjust time fast forward
 - **TIME SET ▼** : to adjust time back
- 3 Release **SET TIME/ALARM OFF** and **TIME SET ▲** or **▼** when you reach the correct setting.
 - The set clock time will show on the display and start to run.

USING THE ALARM

This set allows you to set one alarm (alarm 1 or alarm 2), or set two alarms simultaneously. This set also offers you two alarm modes: Auto (radio) and Buzz.

SETTING THE ALARM TIME

- 1 Hold down **SET ALARM 1** or **SET ALARM 2**
- 2 Press **TIME SET ▲** or **▼** repeatedly, or hold down **TIME SET ▲** or **▼** to adjust minute and/or hour.
- 3 Release **SET ALARM 1** or **SET ALARM 2**, and **TIME SET ▲** or **▼** when you reach the desired time setting. The display will return to the clock time.

SELECTING THE ALARM MODE

- 1 Adjust **AL1/AL2/AL1+2** to **AL1** (alarm 1), or **AL2** (alarm 2), or **AL1+2** (alarm 1 + alarm 2) .
- 2 Select your choice of alarm mode by adjusting **OFF/ ON/ AUTO/ BUZZ** to **AUTO** or **BUZZ**.
 - The corresponding alarm indicator(s) will light up.

Helpful Hint:

- If you have selected the radio mode, make sure you have adjusted the volume loud enough to wake you.
- The buzzer is set at a fixed volume and cannot be adjusted.

SWITCHING OFF THE ALARM

There are three ways of switching off the alarm. Unless you cancel the alarm completely, the **24 hour alarm reset option** will be automatically selected after 59 minutes, from the time your alarm time first goes off.

24 HOUR ALARM RESET

If you want the alarm mode to be stopped immediately but also wish to retain the same alarm setting for the following day:

- Press **SET TIME/ALARM OFF** during the alarm call.

CANCELING THE ALARM COMPLETELY

To cancel the set alarm time before it goes off, or during the alarm call:

- Adjust **OFF/ON/AUTO/BUZZ** to **OFF** position.

REPEAT ALARM

This repeats your alarm call at 7-8-minute intervals.

1 During the alarm call, press **REPEAT ALARM**.

2 Repeat if desired for up to 59 minutes.

SLEEP

This set has a built-in timer which enables the set to be automatically switched off during radio playback after a set period of time. This allows you to lie back, listen and fall asleep. The maximum sleep time is 59 minutes.

Setting SLEEP

1 Set **OFF/ON/AUTO/BUZZ** to **OFF** position.

2 Set your sleep time by pressing on the **SLEEP** button. Keep your finger on the button and the display will begin to count down from 0:59 to 0:00 minute.

→ To cancel sleep, press **SET TIME/ALARM OFF**.

→ To view the remaining sleep time, press **SLEEP**.

TROUBLESHOOTING

If a fault occurs, first check the points listed below before taking the set for repair.

If you are unable to remedy a problem by following these hints, consult your dealer or service center.

WARNING: Under no circumstances should you try to repair the set yourself, as this will invalidate the warranty. Do not open the set as there is a risk of electric shock.

Problem

– Possible Cause

- Remedy

No sound/power

– Volume not adjusted

- Adjust the volume

Occasional crackling sound during FM broadcast

– Weak signal

- Adjust the position of the power cord

Continuous crackling/hiss disturbance during AM broadcast

– Electrical interference from TV, computer, fluorescent lamp, etc.

- Move set away from other electrical equipment

The alarm does not function

– Alarm time not set and/or alarm mode not selected

- Set the alarm time and / select alarm mode

– Volume too low for RADIO

- Adjust the volume

– Radio alarm not adjusted to radio station

- Tune to a radio station

MAINTENANCE

- If you do not intend to use the set for a long time, withdraw the power plug from the wall outlet. In addition to this, it is advisable to remove the battery from the clock radio. This will prevent any danger of leakage and the clock radio will not be damaged.
- Do not expose the set to humidity, rain, sand or excessive heat caused by heating equipment or direct sunlight.
- To clean the set, use a soft, slightly dampened chamois leather. Do not use any cleaning agents containing alcohol, ammonia, benzene or abrasives as these may harm the housing.

ENVIRONMENTAL INFORMATION

We have reduced packaging to the minimum for easy separation into two materials: paper and cardboard.

Your set consists of materials which can be recycled if disassembled by a specialized company. Please observe local regulations on the disposal of packing materials and old equipment.

The set complies with the FCC-Rules, Part 15.

Operation is subject to the following two conditions:

- 1. This device may not cause harmful interference, and*
- 2. This device must accept any interference received, including interference that may cause undesired operation.*

MAGNAVOX LIMITED WARRANTY

Ninety (90) Days Free Product Exchange

MAGNAVOX warrants this product against defect in material or workmanship, subject to any conditions set forth as follows:

PROOF OF PURCHASE:

You must have proof of the date of purchase to exchange the product. A sales receipt or other document showing the product and the date that you purchased the product as well as the authorized retailer included, is considered such proof.

COVERAGE:

Warranty coverage begins the day you buy the product. For a period of ninety (90) days from the date of purchase, if the product is determined to be defective, Magnavox will exchange the defective product with a new or renewed product, at its option, at no charge. The replacement product is covered only for the warranty period of the original product. When the warranty on the original product expires, the warranty on all replaced products also expires. When it is necessary for you to ship the product to Magnavox for exchange, you will pay the shipping cost for shipment to Magnavox. Magnavox will pay the shipping costs when returning a product to you.

Note: The exchange model supplied will be the most comparable one in Magnavox current inventory. Shipping of your product to Magnavox implies intent to follow the specified requirements of the warranty and exchange program. Product received by Magnavox cannot be returned. Replacement product can only be sent if all warranty requirements are met. Failure to follow all requirements can result in delay of exchange process.

EXCLUDED FROM WARRANTY COVERAGE

Your warranty does not cover:

- Shipping charges to return defective product.
- Labor charges for installation or setup of the product, adjustment of customer controls on the product, and installation or repair of antenna systems outside of the product.
- Product repair and/or part replacement because of improper installation, connections to improper voltage supply, abuse, neglect, misuse, accident, unauthorized repair or other cause not within the control of Magnavox.
- A product that requires modification or adaptation to enable it to operate in any country other than the country for which it was designed, manufactured, approved and/or authorized, or repair of products damaged by these modifications.
- Damage occurring to product during shipping when improperly packaged or cost associated with packaging.
- Product lost in shipment and no signature verification of receipt can be provided.
- A product used for commercial or institutional purposes (including but not limited to rental purposes).
- Product sold AS IS or RENEWED.

WHERE WARRANTY EXCHANGE IS AVAILABLE:

Exchange is available in all countries where Magnavox officially distributes the product. In countries where Magnavox does not distribute the product, the local Magnavox organization will attempt to exchange the product, although there may be a delay if the appropriate product is not readily available or special customs processes are implied.

FOR EXCHANGE IN THE U.S.A., PUERTO RICO, OR U.S. VIRGIN ISLANDS...

Contact Magnavox Customer Care Center at:
1-800-705-2000

FOR EXCHANGE IN CANADA...

1-800-661-6162 (French Speaking)
1-800-705-2000 (English or Spanish Speaking)

REPLACEMENT AS PROVIDED UNDER THIS WARRANTY IS THE EXCLUSIVE REMEDY FOR THE CONSUMER. MAGNAVOX SHALL NOT BE LIABLE FOR ANY INCIDENTAL OR CONSEQUENTIAL DAMAGES FOR BREACH OF ANY EXPRESS OR IMPLIED WARRANTY ON THIS PRODUCT. EXCEPT TO THE EXTENT PROHIBITED BY APPLICABLE LAW, ANY IMPLIED WARRANTY OF MERCHANTABILITY OR FITNESS FOR A PARTICULAR PURPOSE ON THIS PRODUCT IS LIMITED IN DURATION TO THE DURATION OF THIS WARRANTY.

Some states do not allow the exclusions or limitation of incidental or consequential damages, or allow limitations on how long an implied warranty lasts, so the above limitations or exclusions may not apply to you. In addition, if you enter into a service contract agreement with the MAGNAVOX partnership within ninety (90) days of the date of sale, the limitation on how long an implied warranty lasts does not apply.

This warranty gives you specific legal rights. You may have other rights which vary from state/province to state/province.

Magnavox, P.O. Box 671539, Marietta, GA. 30006-0026

(Warranty: 4835 710 27750)