

3500 OWNER'S MANUAL



WARNING:

Improper installation, adjustment, alteration, service or maintenance can cause property damage, injury or death. Read the installation, operation and maintenance instructions thoroughly before installing or servicing this equipment.

FOR YOUR SAFETY:

Do not store or use gasoline or other flammable vapors and liquids in the vicinity of this or any other appliance.

Post in a prominent location, instructions to be followed in the event the user smells gas. This information shall be obtained by consulting the local gas supplier.

MODEL: 3500

INSTALLATION, OPERATION, MAINTENANCE, SERVICE AND PARTS MANUAL



35 Garvey Street • Everett • MA 02149

Tel: (617) 387-4100 • Fax: (617) 387-4456 • Toll Free: (866) 698-3188 • Outside MA Fax: (800) 227-2659

E-mail: custserv@mfi.com • Web site: www.mfii.com

TABLE OF CONTENTS

INTRODUCTION

BASIC FUNCTIONING	1
SERVICE	1

INSTALLATION

ASSEMBLY	2
SETTING IN PLACE	2
MECHANICAL CONNECTIONS	2
WATER CONNECTIONS	2
INSTALLATION CHECK-OUT	2
INITIAL CONTROL SETTINGS	2
COOKER CHECK-OUT	2
SHUT-DOWN PROCEDURE	3
REVERSING THE DOORS	3

OPERATION

OPERATING CONTROLS AND INDICATORS ...	3
OPERATING PROCEDURES	3
STEAM SOURCE OPERATING	4
PREHEATING	4
COOKING	4
SHUT-DOWN PROCEDURE	4
CLEANING	4
DRAINAGE	4
COOKING COMPARTMENT DRAINAGE	4
DRIP / SPILL TROUGH DRAINAGE	4
CONTROLS AND INDICATORS	5
FACTS ON PARADE	6
TIMER SETTINGS	7

PRINCIPLES OF OPERATION

GENERAL	9
PLUMBING CIRCUITS	9
STEAM INLET LINE	10
STEAM EXHAUST AND DRAIN LINES	10
STEAM EXHAUST CONDENSING SYSTEM	10
ELECTRICAL CIRCUITS	10
CONTROL CIRCUIT COMPONENTS	10
PICTORIAL DIAGRAM OF STEAM AND WATER.....	11

CIRCUITS	11
INDICATOR LIGHTS	11
BUZZER	11
DOOR INTERLOCK SWITCH	11
THERMOSTATIC SWITCH	11

TROUBLE-SHOOTING

GENERAL	12
GENERAL TROUBLE-SHOOTING GUIDE	12
INCOMING POWER	13
ELECTRIC INSPECTION	13
60 MINUTE TIMER	13
TIMER CONTACTS	13
ELECTRICAL FAULT ISOLATION GUIDE	13
WIRING AND SCHEMATIC DIAGRAM	14
TIMER MOTOR	15
DOOR INTERLOCK SWITCH	15
STEAM SOLENOID VALVES	15
INDICATOR LIGHTS	15
COOKING COMPARTMENT THERMOSTATIC SWITCH	15
BUZZER	16
COLD WATER CONDENSER CIRCUIT	16

MAINTENANCE

GENERAL	16
PREVENTIVE MAINTENANCE	16
COOKING COMPARTMENT CLEANING	17
REPAIR AND REPLACEMENT	17
DOOR LATCH TENSION ADJUSTMENT	17

ILLUSTRATED PARTS LIST

GENERAL	17
ORDERING INFORMATION	17
CABINET ASSEMBLY	18
DOOR ASSEMBLY	20
CONTROL PANEL ASSEMBLY	21
CONDENSER ASSEMBLY	22
COMPLETE CONDENSER ASSEMBLY	23

INTRODUCTION

This service and parts manual contains general information, installation operation, principles of operation, trouble-shooting, and maintenance information for the Market Forge 3500 Pressureless Steam Cookers. Also included is a parts list in which each replaceable part is identified and shown in an accompanying exploded view.

The 3500 is a pressureless steam cooker consisting of two independently controlled compartments enclosed in a single cabinet. Each compartment is equipped with a separate three-piece door with inner gasket plate isolated from the exterior surface.

Door latches operate by action for positive sealing of inner door. Steam and steam-condensing circuits are electrically controlled. Operating controls are displayed on a single front-mounted panel and include separate timers with indicator lights for selection of constant steam or 60 minute long duration cooking.

A separate steam source required for operation of the Pressureless Cooker is normally purchased with it, please refer to the respective manual for guidance.

BASIC FUNCTIONING:

The Model 3500 may be operated with only one compartment in use; or both may be used simultaneously. Each compartment is equipped with identical controls, allowing selection of constant steam or 60 minute timer operation.

The cooker becomes operational when it is set to constant steam, or the timer is set at the desired cooking time and the compartment door is closed. The indicator light comes on and the steam solenoid valve opens, allowing steam to flow into the compartment.

When steam flowing inside the compartment has raised the interior temperature to 195°F, the contacts of a thermostatic switch automatically close, completing the circuit to the timer motor and starting the cooking time period.

At the end of the set interval, timer contacts switch to shut off the cooking operation and sound a signal buzzer. The buzzer is silenced by returning the timer dial to the OFF position. In the constant steam mode, operation will be continuous.

Steam emitted from the compartment along with liquid cooking drainage is directed through a drain screen inside the compartment into the cooker drain line.

A cold water solenoid valve connected into the cooker drain line is automatically actuated by a thermostatic switch in the boiler drain to condense the steam to water prior to discharge into the boiler drain.

SERVICE:

Required service, both preventive and corrective, is explained in Section 6. Should repairs be required, a network of authorized agencies is available to assist with prompt service.

A current Directory of Authorized Service Agencies may be obtained by contacting:

Market Forge Industries Inc.
35 Garvey Street
Everett, Massachusetts 02149-4403
Telephone: (617) 387-4100
Toll Free: (866) 698-3188
Fax: (617) 387-4456
Outside MA Fax: (800) 227-2659
Parts / Price / Service Telephone: (888) 259-7076
custserv@mfii.com
www.mfii.com

The model and serial numbers must be referenced when corresponding with Market Forge.

The data plate containing the serial number pertaining to the equipment is located on the lower front trim of the cabinet.

INSTALLATION

ASSEMBLY:

The Pressureless Cooker is factory-mounted on a cabinet base containing either a steam boiler or direct steam connection controls for the cooker. The assembled unit is shipped bolted to a skid, with cabinet feet in a separate container. Steps required for assembly are as follows:

1. Remove the four bolts that fasten the equipment frame to the skid.
2. Install feet in threaded mounting locations of the cabinet frame.
3. Mount the two baffles on studs located on the right-inside of the cooking compartments.
4. Mount the four pan support racks in brackets inside control compartments.
5. Attach panels to lower cabinet. Detailed instructions are enclosed with the panels.
6. Attach the drip trough on studs located on the face of the unit.

SETTING IN PLACE:

The location of installation must be under an exhaust hood, which will remove small amounts of water vapor emitted when the cooker doors are opened, and exhaust fumes from the air. Level the unit in final location by turning the adjustable feet. Using the cabinet top as a reference, obtain level adjustment left-to-right and front-to-back.

MECHANICAL CONNECTIONS:

Since the Pressureless Cooker is interconnected at the factory to the steam boiler or direct steam plumbing, no field connections to the cooker are required. All electrical and plumbing connections are routed to the steam boiler cabinet through the 6 inch high space between the floor and the bottom edge of the cabinet frame. Connection locations for the cooker mounted on steam boilers of electric, gas, and steam coil utility and direct-connected steam are shown in separate installation instructions for each.

WATER CONNECTIONS:

Before connecting water to this unit, have water supply analyzed to make sure that hardness is no greater than 2.0 grains per gallon and pH level is within the range of 7.0–8.5. Water that fails to meet these standards should be treated by the installation of a water conditioner.

Equipment failure caused by inadequate water quality is not covered under warranty.

CAUTION:

PVC or CPVC are not acceptable materials for drains.

INSTALLATION CHECK-OUT:

Check-out procedures for the cooker mounted on steam boilers of electric, gas, and steam coil utility or direct-connected steam are given in separate installation instructions for each. If the cooker fails to perform as described, consult the Trouble-Shooting Guide for corrective action. If difficulty arises with the boiler, reference the separate service and parts manual for that equipment.

Before making this check-out, the operator must be thoroughly familiar with the operating procedures on page 3 and with the function of each control described in Table 1 on page 5. Reference Figure 1, also on page 5 for identification of controls required in the following procedures.

INITIAL CONTROL SETTINGS:

Before beginning the start-up procedures for the cooker, the instruction plate and service manual for the steam boiler must be consulted and all start-up procedures completed to supply 15 PSI steam to the steam inlet line for the cooker.

1. All steam boiler controls are in the operating mode and 15 PSI steam is applied to the cooker inlet plumbing.
2. Cooker timers for both compartments (Figure 1, page 5) are in the OFF position.
3. Cooker compartments are empty of all information materials, pan supports are mounted in place, and doors are open.

COOKER CHECK-OUT:

The cooker check-out procedures are as follows:

1. With the doors open set timers to about the “4 minute” position. Observe that indicator lights are off and steam does not enter compartments.
2. Close cooker compartment doors. Observe that indicator lights turn on, and steam can be heard rushing into the compartment simultaneously with the door closing.
3. Observe the boiler drain line for passage of steam into the open floor drain. Correct steam condenser operation is evidenced by presence of water flow-

INSTALLATION

ing from the drain line.

4. Observe cooker operation for several minutes. Operation is correct if timer dials begin to rotate after a short delay period required for preheating. After the delay period plus the "4 minute" initial setting, the timer dials will return to the "0 minute" position, at which a buzzer sounds. The buzzer is silenced by turning the dial to the OFF position.

SHUT-DOWN PROCEDURE:

No shut-down procedure is required for the Pressureless Cooker except to check that all timer dials (2) are in the OFF position and the compartment doors are open. Consult the steam boiler instruction plate and complete the shut-down procedures for the boiler.

REVERSING THE DOORS:

The Pressureless Steam Cooker has a reversible cooking compartment door. This section contains instructions for reversing this door.

1. Open the cooking compartment door.
2. Remove the two screws that attach the top hinge to the front of the unit.
3. Slide the door upward, off the bottom hinge.
4. Remove the two screws that attach the bottom hinge to the front of the unit.
5. Remove the plastic hole plugs from the front of the unit. Push the black hole plugs into the left-upper and -lower hinge mounting holes.
6. Reinstall the top hinge with spacers and screws into the right-lower hinge mounting hole. Rotate the hinge 180° for installation, so that the pin that the door rides on is now facing UP.
7. Remove the door latch assembly from the face of the unit. The two nuts mounting the door latch are located behind the face of the unit and must be accessed by removing the control panel. First

shut off the power to the unit at its source then remove the control panel by unscrewing the eight mounting screws and pulling the panel away from the front frame.

8. Remove the two white hole plugs from the left door latch mounting holes, and insert them into the right door latch mounting holes (where the door latch assembly was originally mounted).
9. Rotate the door latch assembly 180°, and install into the left door latch mounting holes.

NOTE: *Each stud on the latch assembly should have a plastic washer, a spring, a plastic washer, and a Nyloc type nut.*

10. To adjust the tension of the door latch, tighten both nuts down until the springs are fully compressed, then back each nut off 1/2 turn.
11. Replace the control panel, and reconnect the power to the unit.
12. Remove the inner door assembly by removing the six screws and spacers on the top and bottom of the door.
13. Move the magnet and magnet clip to the opposite side of the inner door panel (see fig. 5, page 20).
14. Put the door back together, making sure the magnet is located at the top of the door, and refasten it together with the six screws and spacers into the top and bottom of the door.
15. Rotate the door 180° for mounting.
16. Slide the remaining hinge into the top door bearing.
17. Slide the door and hinge assembly down onto the hinge that you have already mounted to the front of the unit. Use the two to mount the top hinge into the right upper hinge mounting holes.

NOTE: *Be sure to include spacer washers behind*

OPERATION

OPERATING CONTROLS AND INDICATORS:

The controls and indicators required to operate the Pressureless Steam Cooker are listed in Table 1 on page 5, together with a short functional description of each. Figure 1 on page 5 shows the physical location of each control and indicator.

OPERATING PROCEDURES:

The 3500 Pressureless Steam Cooker defrosts frozen foods and cooks fresh and defrosted foods. Each cooking compartment permits selection of continuous (constant steam) cooking or timed (0–60 minutes) cooking. Instructions for operation are included in this section. Consult Test Kitchen Bulletin for detailed cooking information.

OPERATION

STEAM SOURCE OPERATION:

The Pressureless Cooker is supplied mounted on a cabinet containing either a steam boiler or controls for direct-connected steam. Manual controls are accessed by opening the cabinet door. The start-up procedure for the steam source is completed once before each daily operating period of the cooker. (For steam boilers, see instruction plate.)

PREHEATING:

Before each initial operation of the cooker, and at any other time when the cooking compartment is cold, a one minute preheating period is required. To preheat the cooker, put steam source into operation and proceed as follows:

1. Close cooking compartment door.
2. Set 60 Minute Timer Dial (1) to "one minute" setting.

NOTE:

Total elapsed preheating time equals the timer setting plus a short delay period needed to activate a thermostatic switch included in the controls.

3. Turn off buzzer, which sounds to indicate cooking is complete, by setting the Timer Dial (1) to OFF position.

COOKING:

Before loading the cooker, be sure compartment is hot. Refer to the preheating section above for instructions.

1. Slide pans of food into cooking compartment pan supports.
2. Close cooking compartment door.
3. Set timer cooking time:
 - a. Constant steam - for continuous cooking.
 - b. 60 minute timer - for timed cooking.
4. Set appropriate timer to the required cooking time (see Test Kitchen Bulletin #59).
5. Turn off buzzer, which sounds to indicate cooking is complete, by setting timer dial (1) to the OFF position.
6. Open door slightly at first letting most of the steam

out of the compartment and then fully open the door.

7. Unload by sliding pans of food from pan supports, taking care to avoid hitting compartment opening.

SHUT-DOWN PROCEDURE:

No shut-down procedure is required for the cooker except to check that both timer dials (1) are in the OFF position and that both compartment doors are open. When all cooking has been completed for the day, the steam source must be shut off. (For steam boilers, see instruction plate.)

CAUTION:

When the unit is not in use, leave the cooking compartment door slightly ajar to prolong the life of the door gasket.

CLEANING:

After each period of daily operation (more frequently as required to maintain cleanliness), the cooker should be thoroughly cleaned by completing the following steps:

1. Remove left- and right-side pan supports, baffles, and drain screens by lifting up and off mounting studs. Wash with a mild detergent. Rinse and set aside for reassembly.
2. Wash cooking compartment interior using a mild detergent and water. Rinse and dry thoroughly.
3. Replace pan supports, baffles, and drain screens in compartment and leave door open.

DRAINAGE:

○ COOKING COMPARTMENT DRAINAGE:

The bottom of the cooking compartment is angled slightly toward the rear of the unit. This assures that any condensate build-up or spills will be directed toward the drain hole, which is located at the rear bottom center of the cooking compartment. Any liquid exiting the cooking compartment runs down the cooking compartment drain tube and into the drain line.

DRIP/SPILL TROUGH DRAINAGE:

The 3500 Pressureless Steam Cooker has a drip/spill trough below the cooking compartment door. It will catch any condensate gathering on the front of the unit when the door is opened.

OPERATION

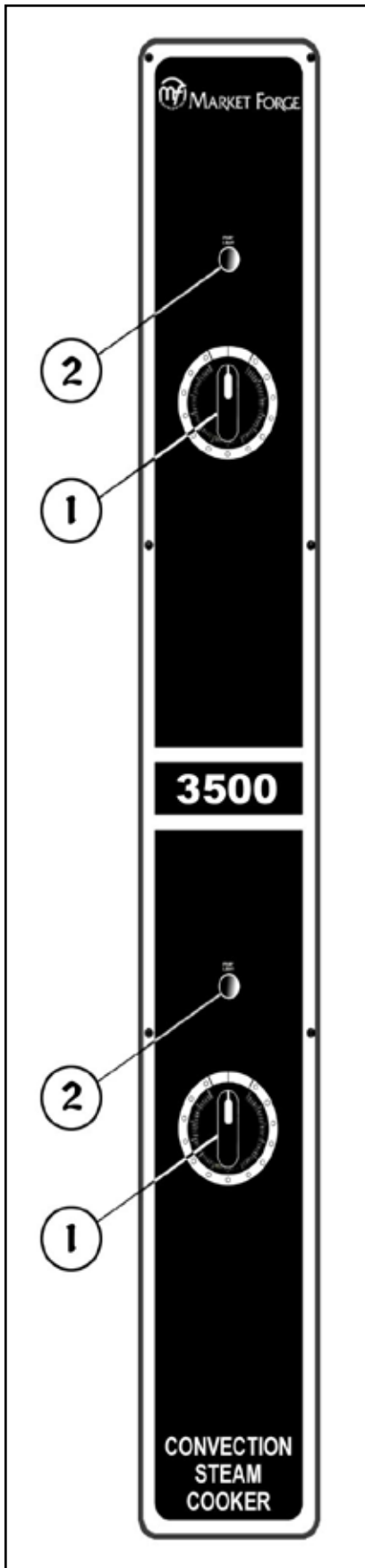

Fig. 1 Control Panel

TABLE 1
CONTROLS & INDICATORS (Refer to Fig. 1)

ITEM	DESCRIPTION	FUNCTION
1	Timer/Constant Steam	Controls cooking up to 60 minutes for uses constant operation.
2	Indicator Light (<i>Red</i>)	Indicated when lit that the cooker is in operation.
3	Buzzer (<i>Not Shown</i>)	Signals end of cooking period.

OPERATION

TEST KITCHEN BULLETIN

MODEL 3500 PRESSURELESS COOKER FACTS ON PARADE

1. Frozen vegetables should always be cooked in perforated 12" x 20" x 2 1/2" pans 7 1/2 lbs (34 kg) maximum per pan.
2. Frozen entrees should be underlined with a perforated pan for best results. If they are defrosted first, the heating time will be decreased.
3. Fresh foods may also be cooked in this unit. Vegetables and other foods where the stock is not to be retained should be cooked in perforated 12" x 20" x 2 1/2" pans for the most nutritious results.
4. There is a thermostatic time delay built into this unit which adapts the unit to the proper cooking time. This means that the total time will usually be longer than the time setting.
5. There is a safety microswitch on the door which shuts off the steam each time the door is opened if the unit is in the cooking cycle.
6. Both compartments may be filled and timers set simultaneously.
7. Total cooking time will vary depending on the load, even though the timer setting is the same.
8. All foods, except cakes and pastry, can be cooked in a steam cooking unit.
9. Steam cooked meals have greater nutritional value since they retain most of their vitamins and minerals.
10. Because foods are cooked faster by the higher temperatures of steam cooking, they can be prepared closer to serving time, insuring maximum freshness.
11. Steam cooked foods have a higher percent yield more portions per dollar spent.
12. Food may be served from the same pan in which it is steam cooked, thus reducing food breakage since there is no extra handling or transferring of food from cooking pans to serving pans. It also reduces pot washing tasks.
13. Some important advantages of steam cooking are labor saving, reduced operating costs, space saving, and the lifting of heavy stock pots is eliminated.
14. Rice and spaghetti products, if thoroughly wet at the start of the cooking process, are very easily prepared.
15. Food such as potatoes, poultry, seafood, and some meats may be blanched in the steam cooker, thus reducing the total cooking time and grease absorption.
16. Fuel is used only when the steam cooking unit is in operation.
17. The steam cooker will loosen foods burned on pans making washing easier.
18. Solid pans are recommended when liquid is to be retained and perforated pans when the liquid is not to be retained.
19. Eggs may be cooked out of the shell if they are to be chopped which eliminates peeling after steaming.
20. The steam cooker can be opened during the cooking period to add or remove items. If any time is lost, and adjustment may be make on the timer.
21. Steam cooking information, including recommended pan size and type, weight per pan, cooking times and pan yields are given on the following pages of this bulletin.

OPERATION

PRESSURELESS STEAM COOKING TIMER SETTINGS

The 3500 Pressureless Cooker is a two compartment unit. Each compartment holds five 12" x 20" x 2 1/2" or three 12" x 20" x 4" pans. This unit enables the cook to prepare foods close to the time of service. The cooking times given are timer settings and should be set on a preheated compartment. There is a thermostatic time delay in each compartment that adjusts the total time depending on the temperature and amount of the food. Therefore the total time will be greater than the timer setting. At the end of the timer cooking cycle the bell will ring, steam will stop flowing and the food can be removed.

FROZEN VEGETABLES

ITEM	APPROX. FROZEN WT. PER PAN	RECOMMENDED PAN SIZE, 12" x 20" PERFORATED	NUMBER OF PANS	TIMER SETTINGS IN MINUTES	APPROX/ NO. COOKED SERVINGS PER PAN
Asparagus Spears	7 1/2 lbs. (3.4 kg)	2 1/2" (65mm)	1-3	12-15	30 3 oz. (85 g)
Beans, Green Regular	6 lbs. (2.7 kg)	2 1/2" (65mm)	1-3	10-15	25 3 oz. (85g)
Beans, Green French Cut	6 lbs. (2.7 kg)	2 1/2" (65mm)	1-3	5-7	25 3 oz. (85 g)
Beans, Lima	7 1/2 lbs. (3.4 kg)	2 1/2" (65mm)	1-3	12-15	30 3 oz. (85 g)
Broccoli	6 lbs. (2.7 kg)	2 1/2" (65mm)	1-3	4-6	25 3 oz. (85 g)
Brussel, Sprouts	7 1/2 lbs. (2.7 kg)	2 1/2" (65mm)	1-3	10-15	30 3 oz. (85 g)
Carrots	6 lbs. (2.7 kg)	2 1/2" (65mm)	1-3	10-15	25 3 oz. (85 g)
Cauliflower	6 lbs. (2.7 kg)	2 1/2" (65mm)	1-3	7-12	25 3 oz. (85 g)
Corn-Cut	7 1/2 lbs. (3.4 kg)	2 1/2" (65mm)	1-3	8-12	30 3 oz. (85 g)
Mixed Vegetables	7 1/2 lbs. (3.4 kg)	2 1/2" (65mm)	1-3	8-12	30 3 oz. (85 g)
Peas (Loose)	7 1/2 lbs. (3.4kg)	2 1/2" (65mm)	1-3	3-5	30 3 oz. (85 g)
Spinach	9 lbs. (4kg)	2 1/2" (65mm)	1-3	Must be Defrosted	30 4 oz. (115 g)
Squash	12 lbs. (5.4 kg)	2 1/2" (65mm)	1-3	Must be Defrosted	50 3 oz. (85 g)

FROZEN PREPARED ENTREES

Lobster Tails 6-8 oz. (170-255 g)	7-8 lbs. (3.2-3.6 kg)	2 1/2" (65mm)	1-3	15-25	15 6 oz. (170 g)
Shrimp, C.D.P.	16-20 lbs. (7-9 kg)	2 1/2" (65mm)	1-3	8-11	75 3 oz. (85g)
Shrimp, Green	16-20 lbs. (7-9 kg)	2 1/2" (65mm)	1-3	11-15	50 3 oz. (85 g)
Bulk Pack, Frozen	3 1/2-4 lbs. (1.6-1.8 kg)	2 1/2" (65mm)	1-3	35-45	10 6 oz. (170 g)
Bulk Pack, Defrosted	3 1/2-4 lbs. (1.6-1.8 kg)	2 1/2" (65mm)	1-3	25-35	10 6 oz. (170 g)

OPERATION

VEGETABLES

ITEM	APPROX. FROZEN WT. PER PAN	RECOMMENDED PAN SIZE, 12" x 20" PERFORATED	NUMBER OF PANS	TIMER SETTINGS IN MINUTES	APPROX/ NO. COOKED SERVINGS PER PAN
Beans, Snap Green or Waxed	6 lbs. (2.7 kg)	2 1/2" (65mm)	1-3	18-22	25-30 3 oz. (85 g)
Beets, 2" Diameter	7 1/2 lbs. (3.4 kg)	2 1/2" (65mm)	1-3	40-50	30-35 3 oz. (85 g)
Broccoli, Stalks 1/2-3/4"	6 lbs. (2.7 kg)	2 1/2" (65mm)	1-3	14-18	25-30 3 oz. (85 g)
Carrots, Sliced	9 lbs. (4 kg)	2 1/2" (65mm)	1-3	18-21	35-40 3 oz. (85 g)
Cauliflower, Trimmed 1 1/2-2"	6 lbs. (2.7 kg)	2 1/2" (65mm)	1-3	12-16	30-35 3 oz. (85 g)
Corn on Cob Husked	1 doz.	2 1/2" (65mm)	1-3	10-15	12
Cabbage 1/4-1/6 of Head, Cored	5 lbs. (2.25 kg)	2 1/2" (65mm)	1-3	14-18	15-20 4 oz. (115 g)
Onions, 2" Diameter	6 lbs. (2.7 kg)	2 1/2" (65mm)	1-3	20-25	25-30 4 oz. (115 g)
Peas, Shelled	5 lbs. (2.25 kg)	2 1/2" (65mm)	1-3	5-6	25-30 3 oz. (85 g)
Potatoes, French Fry Cut	10 lbs. (4.5 kg)	2 1/2" (65mm)	1-3	18-21	50 3 oz. (85 g)
Potatoes, Regular Cut, 3"	10 lbs. (4.5 kg)	2 1/2" (65mm)	1-3	35-40	50 3 oz. (85 g)
Spinach, Cleaned Cut	3 lbs. (1.4 kg)	2 1/2" (65mm)	1-3	3-5	10-12 3 3/4 oz. (105 g)
Squash, Summer, Sliced 1" thick	7 lbs. (3.2 kg)	2 1/2" (65mm)	1-3	7-10	30-35 3 oz. (85 g)
Squash, Winter Peeled	9 lbs. (4 kg)	2 1/2" (65mm)	1-3	10-15	25-30 3 oz. (85 g)
Turnip, Dice	5 lbs. (2.25 kg)	2 1/2" (65mm)	1-3	28-32	20-25 4 oz. (115 g)

CANNED VEGETABLES

Canned, Vegetables	7 lbs. (3.2 kg)	2 1/2" (65mm)	1-3	5-10	25-30 3 oz. (85 g)
-----------------------	--------------------	------------------	-----	------	-----------------------

MISCELLANEOUS

Eggs, in Shell	3 dozen	2 1/2" (65mm)	1-3	9-11	36 1 Egg Each
Eggs, out of Shell	4 dozen	2 1/2" (65mm)	1-3	6-8	48 1 Egg Each
Rice, (See Bulletin #16)	4 lbs. (1.8 kg)	2 1/2" (65mm)	1-2	18-22	60-65 3 oz. (85 g)
Spaghetti, (See Bulletin #13)	3 lbs. (1.4 kg)	2 1/2" (100mm)	1-2	18-22	40-45 4 oz. (115 g)

OPERATION

MEAT, POULTRY, FISH

ITEM	APPROX. FROZEN WT. PER PAN	RECOMMENDED PAN SIZE, 12" x 20" PERFORATED	NUMBER OF PANS	TIMER SETTINGS IN MINUTES	APPROX/ NO. COOKED SERVINGS PER PAN
Chicken, Cut-up	8 lbs (3.6 kg)	2 1/2" (65mm)	1-3	20-30	15-20 2 oz. Protein (55 g)
Chicken, 4 lbs. Whole	3 each	4" (100 mm)	1-3	45-50	25-30 2 oz. Protein (55 g)
Fowl, 5 lbs. or more, Whole	2 each	4" (100 mm)	1-3	50-60	20-25 2 oz. Protein (55 g)
Fish, Fillets	3 lbs (1.4 kg)	2 1/2" (65mm)	1-3	10-15	12-15 2 oz. (55 g)
Frankforts	5 lbs (2.3 kg)	2 1/2" (65mm)	1-3	3-5	35-40 2 oz. (55 g)
Hamburgers, 3 oz. (85 g)	5 lbs (2.3 kg)	2 1/2" (65mm)	1-3	18-22	20-25 2 oz. Protein (55 g)
Meatballs, 1 oz. (30 g), size*	6 lbs (2.7 kg)	2 1/2" (65mm)	1-3	20-25	20-25 2 oz Protein (55 g)
Meatloaf *	15 lbs (6.8 kg)	2 1/2" (65mm)	1-3	40-50	50-60 2 oz. Protein (55 g)
Pork Chops, 4 oz., Loin Bone (115 g)	6 lbs (2.7 kg)	2 1/2" (65mm)	1-3	25-30	24 2 oz. Protein (55 g)
Sausage, 1 1/2 oz. (45 g)	6 lbs (2.7 kg)	2 1/2" (65mm)	1-3	18-21	18-20 2 oz. (55 g)
Turkey, On Carcass	20-22 lbs (9-10 kg)	2 1/2" (65mm)	1	2-2 1/2 hrs.	50-60 2 oz. Protein (55 g)
Turkey, Off Carcass	10-12 lbs (4.5-5 kg)	2 1/2" (65mm)	1-3	1-1 1/4 hrs.	55-65 2 oz. Protein (55 g)

* Raw weight for Meatballs and Meatloaf includes hamburger and extenders and yields 2 oz. (55 g) protein plus extenders or 3 oz. (85 g) total portion.

PRINCIPLES OF OPERATION

GENERAL:

The 3500 Pressureless Steam Cooker consists of two identical cooking compartments, one above the other, in a single cabinet assembly. Each compartment is fitted with independent electrically controlled steam circuits and spring-loaded, self-sealing doors with slam action latches. Compartments can be used separately or simultaneously for either constant steam or 60 minute timing. The principles of operation in this section include an explanation of steam, steam condensing, and electrical circuits and their functioning.

PLUMBING CIRCUITS:

The plumbing circuits consist of the piping, steam solenoid valves, orifice, drain, and cold water condenser required to provide controlled steam application to the cooking compartments. A simplified diagram of

these circuits is shown in Fig. 2 on page 5.

NOTE: Fig. 2 is strictly a pictorial schematic diagram and is not intended to show the actual configuration of the plumbing. All components are shown in correct relationship with each other. However, the diagram does not show their actual locations or position within the cooker.

As shown in the diagram, steam inlet and exhaust connections are connected at the factory directly into a steam boiler or direct-connected steam plumbing enclosed within the base cabinet on which the cooker is mounted. The boiler (or direct-connected steam control system) is equipped to supply constant, regulated steam at 14–15 PSI. Steam exhaust, having been reduced to water by the cold water condenser,

PRINCIPLES OF OPERATION

is directed into the boiler (or direct-connected steam control) drain system. Steam inlet lines for compartments are equipped with normally closed solenoid valves operated by the electrical control circuits. The inlet valves are opened whenever the compartment control circuit is activated by use of the 60 minute timers.

STEAM INLET LINE:

A steam supply line is plumbed from the boiler output (or direct-connected steam control) to a 1/2 inch barb fitting connected to the input sides of both steam inlet solenoid valves. When a cooking compartment is not in use, the valve for the compartment remains closed to prevent steam from entering. During operation, the appropriate inlet solenoid valve is opened by activation of the control circuit.

Steam is projected onto the surface of pans of food loaded into the compartment by an orifice located inside the compartment. Steam continues to flow through the compartment in this manner until the control circuit closes the solenoid valve.

STEAM EXHAUST AND DRAIN LINES:

Perforated strainers at the drain line openings inside each compartment allow only steam, condensation, and liquid cooking drainage to enter. Prior to discharge into the boiler drain system, steam is converted to water by the cold water condensing systems for each compartment.

STEAM EXHAUST CONDENSING SYSTEM:

The steam condensing system consists of the identical, two-position, normally closed cold water solenoid valves, with outlet sides connected into the exhaust plumbing for each cooking compartment. A spray nozzle directs cold water about the inside of the drain lines to increase cold water contact with exhausted steam.

Valve inlet sides are connected remote from the supply line of the steam boiler (or direct-connected steam plumbing). The valves respond to a thermostatic

switch located inside the compartment. When the timer starts the cold water solenoids will energize.

ELECTRICAL CIRCUITS:

The electrical circuits of the cooker control the power to activate timer motors and energize solenoid-operated valves and circuits, which in turn control application of steam to the cooking compartment and condensation of steam from the exhaust line. The cooker operates on 120V, 2 amp, 60Hz electrical service connected to all circuits from the circuits of the steam boiler (or direct-connected steam controls) contained within the cabinet on which the cooker is mounted. Power is supplied to the control circuit at all times when the shut-off device for the unit (supplied by the user) is in the ON position.

CONTROL CIRCUIT COMPONENTS: A brief description of the electrical circuit elements follows.

60 MINUTE TIMER/CONSTANT STEAM:

The timer contains a 120-volt AC synchronous motor that drives a timing dial through a gear reduction and clutch mechanism. The timer dial is manually set for any interval of operation from 0 to 60 minutes or constant steam as read on the calibrated dial face. The manual rotation of the dial moves the common element (1) of the timer switch from the neutral (OFF) position to contact (3), which connects with the steam inlet solenoid valve operating circuit.

The cooker is placed into automatic operation with the setting of the timer dial. Its timing cycle, however, is automatically delayed by a thermostatic switch, which assures operating temperature is achieved before the timer motor begins to "time out." When the timer motor has operated for the preset duration, the common element is transferred to contact (4), returning the inlet solenoid valve to the closed position and energizing the buzzer. Contact to the buzzer circuit remains closed until the dial is manually turned to the OFF position, returning the common element (1) of the timer switch to the neutral position.

PRINCIPLES OF OPERATION

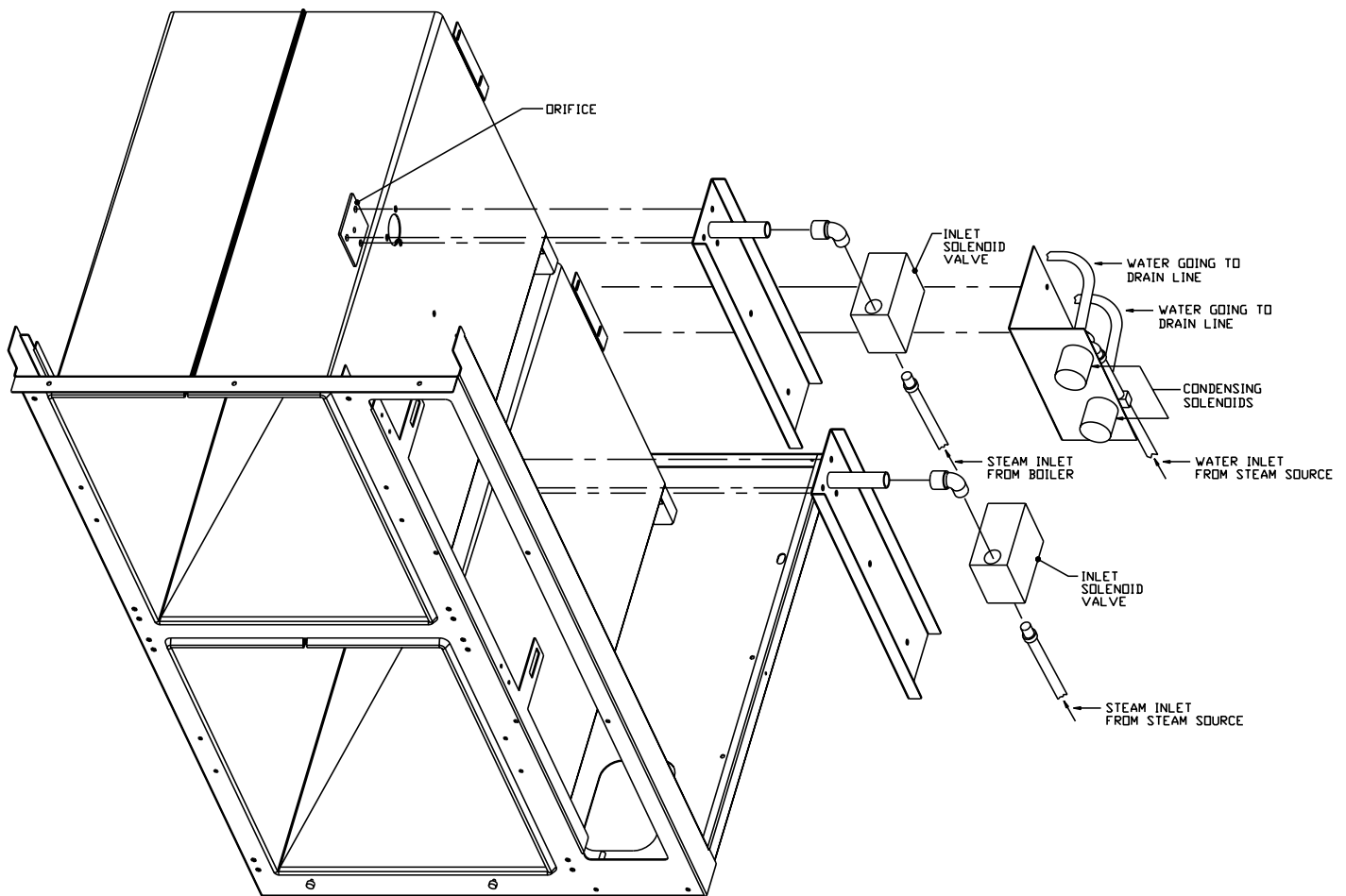

Fig. 2 Pictorial Diagram, Steam and Water Circuits

INDICATOR LIGHTS:

An indicator light is included for both compartments. The light remains on (red) at all times when the coinciding timer dial is set and the door interlock switch is closed. The light turns off at the end of the timed cooking duration.

BUZZER:

The buzzer is an alarm device that operates by oscillation of a striker against the core of an electromagnet. When the 60 minute timer dials reach the "0 Minute" position, the buzzer coil is energized to sound the buzzer. Movement of the timer dial to the OFF position opens the contact to the buzzer coil to shut it off.

DOOR INTERLOCK SWITCH:

The interlock switch is a single-pole proximity switch with normally open contacts. The switch is operated

by the proximity of a magnet within the door. When the door is open, the switch contacts remain in the open position. When the door is closed and securely latched in place, the magnet is near the switch to close the contacts. Connected between the operating contact (3) of the timers and the steam inlet solenoid valve, the door switch acts as a protective device to interrupt valve operation unless the door is closed.

THERMOSTATIC SWITCH:

The thermostatically operated switch is a two-position, normally open switch mounted on the cooking compartment. The switch functions to activate the cold water solenoid valves of the steam condensing system and to delay timer motor operation until the compartment temperature reaches 195°F, thus assuring that cooking temperature exists throughout the timed duration.

TROUBLE-SHOOTING

GENERAL:

The information in this section is intended to assist both the operator and service personnel in locating the general source of problems that may occur with the cooker. Before following any of the procedures given in this section, the operator should be thoroughly familiar with the operating instructions and the function of all controls that are described in the operating section of this manual. If the problem cannot be readily corrected, the operator should contact the nearest Market Forge service agency for assistance.

TROUBLE-SHOOTING GUIDES:

Refer to the trouble-shooting guide for use by service personnel given on page 12-13.

ELECTRICAL FAULT ISOLATION:

Correction of an electrical failure first requires isolation of the fault to a single circuit or component. In most cases, the nature of the failure and its effect upon the operation of the cooker will be sufficient to narrow it down to one or more circuit elements. Refer to the isolating electrical faults table on page 14.

ELECTRICAL TROUBLE-SHOOTING PROCEDURES:

Before performing the trouble-shooting procedures in this section, the serviceman must be familiar with the function of all controls as described in the operating section as well as with the principles of operation section in this manual.

GENERAL TROUBLE-SHOOTING GUIDE

PROBABLE CAUSE	REMEDY
1. INDICATOR LIGHT FAILS TO LIGHT WITH TIMER SET.	
A. Power to Cooker Off.	Located external circuit breaker for incoming power and place in ON position.
B. Door interlock switch contact not closed.	Shut cooker door to close switch contacts. Check alignment of door with switch.
C. Door interlock switch faulty.	Replace switch. (Refer to door interlock switch section on page 15)
D. Indicator light burned out.	Replace light.
E. Faulty timer contacts.	Replace timer. (Refer to 60 minute timer section on page 13)
F. Faulty wiring.	Inspect condition of wire and tightness of all connections. Correct as needed.
2. STEAM FAILS TO ENTER COMPARTMENT WITH INDICATOR LIGHT ON.	
A. Faulty steam solenoid valve.	Replace valve. (Refer to steam solenoid valve section on page 15)
B. Faulty wiring.	Inspect condition of wire and tightness of all connections. Correct as needed.
3. STEAM ENTERS COMPARTMENT CONTINUOUSLY. TIMER DIAL NOT TURNING.	
A. Constant steam position.	Move knob to timing location.
B. Faulty thermostatic switch.	Replace switch. (Refer to cooking compartment thermostatic switch section on page 15)
C. Faulty timer motor.	Replace switch. (Refer to 60 minute timer section on page 13)
D. Faulty steam solenoid valve.	Replace switch. (Refer to steam solenoid valve section on page 15)
E. Faulty wiring.	Inspect condition of wire and tightness of all connections. Correct as needed.
4. STEAM CONTINUES TO FLOW INTO COMPARTMENT AND/OR BUZZER FAILS TO SOUND AT END OF TIMER SETTING.	
A. Timer contacts faulty.	Replace timer. (Refer to 60 minute timer section on page 13)
B. Buzzer faulty.	Replace buzzer. (Refer to cooking compartment thermostatic switch section on page 15)
C. Faulty wiring.	Inspect condition of wire and tightness of all connections. Correct as needed.
5. STEAM FLOWS CONTINUOUSLY FROM BOILER (OR DIRECT CONNECTED STEAM CONTROL) DRAIN LINE WITH COOKER IN OPERATION.	
A. Cold water not connected.	Turn on external shut-off valve.
B. Faulty thermostat.	Replace thermostat. (Refer to cooking compartment thermostatic switch section on page 15)
C. Faulty cold water solenoid.	Replace valve.
D. Faulty wiring.	Inspect condition of wire and tightness of all connections. Correct as needed.

TROUBLE-SHOOTING

The electrical trouble-shooting procedures that follow require access to components and terminals of the electrical control panel shown in Fig. 6 on page 21. Electrical controls are reached by removing screws that fasten the control panel to the frame. The panel may be pulled forward for testing while interconnected to the cooker circuits or disconnected at the pin connection for complete removal and repair.

INCOMING POWER:

Before trouble-shooting any of the electrical parts or assemblies, verify that power is being supplied to the cooker. Incoming power is connected at the boiler (or direct-connected steam) control box located in the base cabinet. With power connected to the cooker, an AC volt-meter is used to measure 120 volts across L1 and L2. If 120 volts is present, and the cooker will not operate, the fault lies within the electrical circuits of the cooker.

ELECTRIC INSPECTION:

The first step in any electrical trouble-shooting procedure is a thorough physical inspection of all wiring connections.

WARNING:

Before removing control panel or checking connections and wiring, be sure that the circuit breaker for incoming power is OFF. When power is supplied, all exposed terminals of the control panel carry 120 volts.

Check all wiring connections by hand to assure that both ends of all connection points are tightly secured. Use a screwdriver to tighten connection points. If necessary, visually inspect all quick-disconnect terminals for evidence of corrosion. Terminals in this condition should be separated, cleaned with emery cloth until shiny, and tightly reconnected.

60 MINUTE TIMER:

○ TIMER CONTACTS:

Defective timer contacts will result in failure of either cooker compartment to operate. When this occurs, remove the control panel and proceed as follows:

1. Turn off power to the cooker at external circuit breaker.
2. Disconnect all five wires from timer terminals. (see Fig. 2, page 11).

ELECTRICAL FAULT ISOLATION GUIDE

FAILURE	FAULT LOCATION
1. Will not operate in either constant steam or 60 minute timer.	A. Incoming power. B. Timer. C. Door interlock switch/relay. D. Wiring.
2. Operating in constant steam position, but not in 60 minute timer.	A. 60 minute timer. B. Wiring.
3. Operating in 60 minute timer position, but not in constant steam.	A. Timer. B. Wiring.
4. Steam solenoid valve fails to open with indicator light on.	A. Solenoid valve coil. B. Wiring.
5. Indicator light off with steam solenoid valve open.	A. Indicator light. B. Wiring.
6. With indicator light off steam solenoid valve open, timer dial fails to turn.	A. Compartment thermostatic switch. B. Constant steam position. C. Timer motor. D. Wiring.
7. Buzzer fails to sound at end of 60 minute timer mode.	A. 60 minute timer contacts. B. Buzzer. C. Wiring.
8. Steam flows continuously form boiler drain line.	A. Thermostatic switch. B. Cold water solenoid valve. C. Wiring.

TROUBLE-SHOOTING

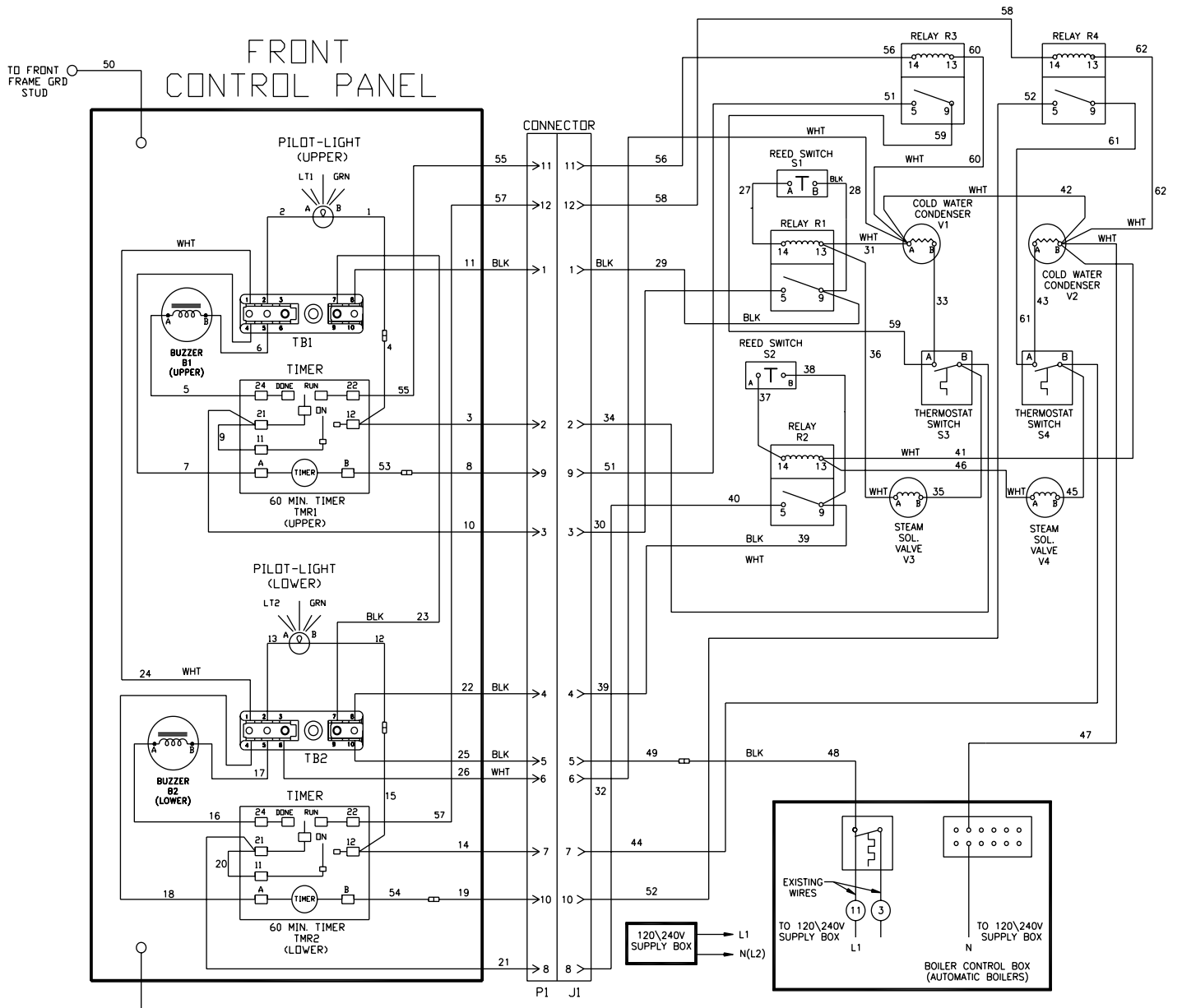

- NOTES: 1. ALL WIRES 18 AWG AND YELLOW EXCEPT WHERE INDICATED OTHERWISE.
 2. FOR WIRE LEAD SCHEDULE REFER TO DRAWING C 91-6472.

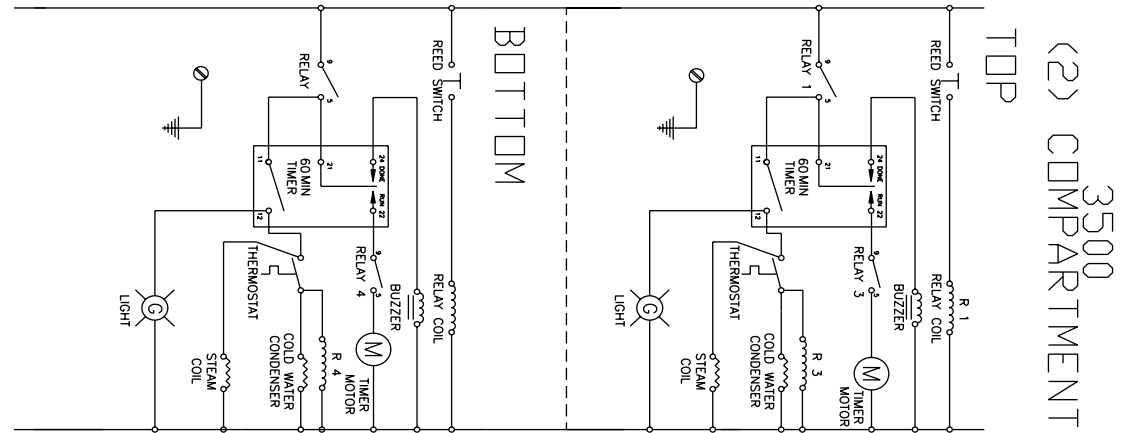

Fig. 3 Wiring and Schematic Diagram

TROUBLE-SHOOTING

3. Connect an ohmmeter between terminals 1 and 3.
 4. Rotate timer dial beyond the "0 Minute" point (*any setting*) to obtain a reading of zero ohms on the ohmmeter. If zero ohm reading cannot be obtained, timer contacts are defective and the timer must be replaced.
 5. Move ohmmeter leads to terminals 1 and 4.
 6. Rotate timer dial to "0 Minute" position (*an audible click indicates correct position*). If zero ohm reading cannot be obtained, the timer is defective and must be replaced.
 7. Remove ohmmeter and replace all five leads on timer terminals as shown in Fig. 2 on page 11.
3. Connect an ohmmeter between the terminals of the switch.
 4. Actuate the switch by closing the cooking compartment door. If a zero reading cannot be obtained, the switch is defective and must be replaced.
 5. Remove the ohmmeter and replace the leads on switch terminals (*see Fig. 2, page 11*).

TIMER MOTOR:

A defective timer motor will cause continuous operation in the Time mode, with the timer dial failing to return to the "0 Minute" position. Since thermostatic switch failure can cause the same symptom, fault must first be isolated to the timer by testing the thermostat (*Refer to cooking compartment thermostatic switch section on page 15*).

1. Carefully check motor wire leads and tighten loose connections.

WARNING:

Use care while working with control panel. Terminals carry 120 volts.

2. Turn on power to the cooker.
3. Set timer dial (any setting beyond "0 Minute"). If operation is correct, the motor will turn the dial toward "0 Minute." If the motor fails to operate, it is defective and the entire timer must be replaced.
4. Shut off power to the cooker.

DOOR INTERLOCK SWITCH:

Malfunction of the cooker door interlock switch prevents timer indicator lights from turning on and steam solenoid from opening when the timer dial is set. If steam does not enter the compartment and the indicator light fails to turn on with the door latch securely engaged, the fault may be in the door interlock switch. Proceed as follows:

1. Turn off power to the cooker.
2. Disconnect wires to the door switch terminals (*see Fig. 2, page 11*).

STEAM SOLENOID VALVES:

When either inlet solenoid valve fails to operate, the fault may be a defective coil. A defective coil is found using an AC volt-meter to check the voltage at the coil wire terminals, with the cooker compartment operating in either constant steam or 60 minute timer mode. If voltage of 120 volts is present and the coil fails to open the valves, the fault is in the valve coil. Defective valve coils are not separately replaceable, requiring complete valve replacement.

INDICATOR LIGHTS:

If the cooker compartment functions correctly, with the single exception that the indicator light fails to light during operation, the fault is a defective indicator light. A "burned out" or defective light is verified by using an AC volt-meter at the leads, with input power on the selector switch in the correct position for that timer, the timer set, and the door latches closed. If 120 volts is present, the fault is in the indicator light and requires replacement. If 120 volts is not present, the fault is in the wiring or control components (selector switch, timer, or door switch).

COOKING COMPARTMENT THERMOSTATIC SWITCH:

A thermostatic switch included in the circuit for the timer motor delays timer operation until steam flowing into the compartment satisfies the temperature-actuated switch device. If a timer motor fails to operate within about one minute after the indicator light comes on (with cooker compartment empty), the cause may be a defective thermostatic switch. To test the switch, proceed as follows:

1. Disconnect the two wires connected to the thermostatic switch terminals.
2. Connect an ohmmeter between the two terminals of the switch.
3. Place the cooker into operation and observe ohmmeter dial. Within one minute of operation, the switch contacts close automatically to register a zero ohm reading on the dial. If a zero ohm reading

TROUBLE-SHOOTING

is not obtained, the switch is defective.

4. Shut off cooker, disconnect ohmmeter leads, and replace wires on switch terminals.

BUZZER:

If the buzzer does not sound at the termination of the operator-selected timer setting (timer dial returned to "0 Minute" position), the fault may be a defective buzzer. Buzzer operation is verified using an AC voltmeter at buzzer coil connections with input power on and selector switch and coinciding timer dial set at the "0 Minute" position. If voltage is 120 volts, the fault is in the buzzer, which must be replaced. If 120 volts is not present, the fault is in the wiring or control components (timer or selector switch).

COLD WATER CONDENSER CIRCUIT:

If during cooker operation steam exits from the drain line opening (located in lower boiler compartment) and the condensing system fails to operate, as evidenced by repeated discharge of water from the drain line, the condensing circuit is malfunctioning. The failure can be caused by a defective condenser thermostat or cold water solenoid coil, or by wiring failure. To test condenser thermostat, refer to cooking compartment thermostatic switch section on page 15.

If the condenser thermostat functions correctly, but either of the cold water solenoid valves fails to operate, the cause might be a faulty valve coil. A defective coil is found using an AC volt-meter to check the voltage

at the coil wire terminals with the cooker compartment in operation. If voltage of 120 volts is present and the valve fails to open, the fault is in the valve coil. Defective valve coils are separately replaceable.

WIRING:

All of the electrical components of the cooker (timers, indicator lights, etc.) are connected to each other by wiring shown in Fig. 2 on page 11.

If all of the electrical components are operating correctly (and the incoming power has been checked), but the cooker fails to operate, the fault lies in the wiring.

Fig. 2 on page 11 is a diagram that shows all terminals and interconnections within the electrical circuits. All numbered terminals are identified and all leads number-coded as shown. Connections can be easily removed.

Figure 3 on page 14 also shows the schematically information and is an aid in isolating circuits for testing.

Using an ohmmeter, wiring continuity between the connections shown on the wiring diagram (Fig. 2, page 11) is readily verified. This is best done in stages, removing only those wires required for each continuity check. As each lead is replaced, it should be checked for evidence of corrosion, and cleaned if necessary. All leads must be tightly attached so as to provide a good electrical connection.

MAINTENANCE

GENERAL:

This section contains both preventive and corrective maintenance information. Preventive maintenance may be performed by maintenance personnel at the establishment in which the cooker is installed. It is recommended that user personnel never attempt to make repairs or replacements to the equipment without the assistance of authorized service. Assistance in service methods or a current Directory of Authorized Agencies may be obtained from Market Forge (Refer to service section on page 1).

PREVENTIVE MAINTENANCE:

A good preventive maintenance program begins with

the daily cleaning procedure described in the cleaning section on page 4. Additional preventive maintenance operations are presented in this section. In establishments that employ full-time maintenance personnel, the tasks described can be assigned to them. For other installations, tasks requiring mechanical or electrical experience should be performed by an authorized service agency.

The following paragraphs set forth minimum preventive maintenance procedures that must be completed periodically to assure continued trouble-free operation of the cooker.

MAINTENANCE

CAUTION:

Under no circumstances should hardware (or parts) be replaced with a different length, size, or type other than as specified in the parts list. The hardware used in the cooker has been selected or designed specifically for its application, and the use of other hardware may damage the equipment and will void any warranty.

COOKING COMPARTMENT CLEANING:

A daily cleaning of the cooking compartments and pan supports is required. See cleaning section on page 4 for details.

REPAIR AND REPLACEMENT:

Refer to Illustrated parts section of this manual contains a listing of all replaceable parts and associated

exploded views of the 3500 Cooker. In most cases, disassembly procedures will be obvious from the exploded views. Instructions follow for procedures that are not readily apparent.

DOOR LATCH TENSION ADJUSTMENT:

CAUTION: Shut off main electrical power to unit.

1. Open the cooking compartment door.
2. Remove the control panel by removing the eight mounting screws and disconnecting the wire plug and restraining wire.
3. Tighten both nuts down until the springs are fully compressed.
4. Back each nut off 1/2 turn.
5. Remount the control panel, reconnecting wire plug and restraining wire.

ILLUSTRATED PARTS LIST

GENERAL:

This section contains a complete listing of all replaceable parts of the 3500. For the purpose of parts identification, the unit is broken down into functional assemblies, and each assembly is shown in an exploded view that is keyed to the accompanying parts list. Each parts list contains the figure index number, the Market Forge part number, and an abbreviated description.

ORDERING INFORMATION:

Orders for repair parts should be directed to the nearest authorized parts distributor. For a current Market Forge Authorized Parts Distributor List, contact:

Market Forge Industries Inc.
35 Garvey Street
Everett, Massachusetts 02149-4403
Telephone: (617) 387-4100
Toll Free: (866) 698-3188
Fax: (617) 387-4456
Outside MA Fax: (800) 227-2659
Parts / Price / Service Telephone: (888) 259-7076
custserv@mfii.com
www.mfii.com

All orders should contain the Market forge part number(s), the part description(s), and the model and serial number of the cooker for which the part or parts are ordered.

ILLUSTRATED PARTS LIST

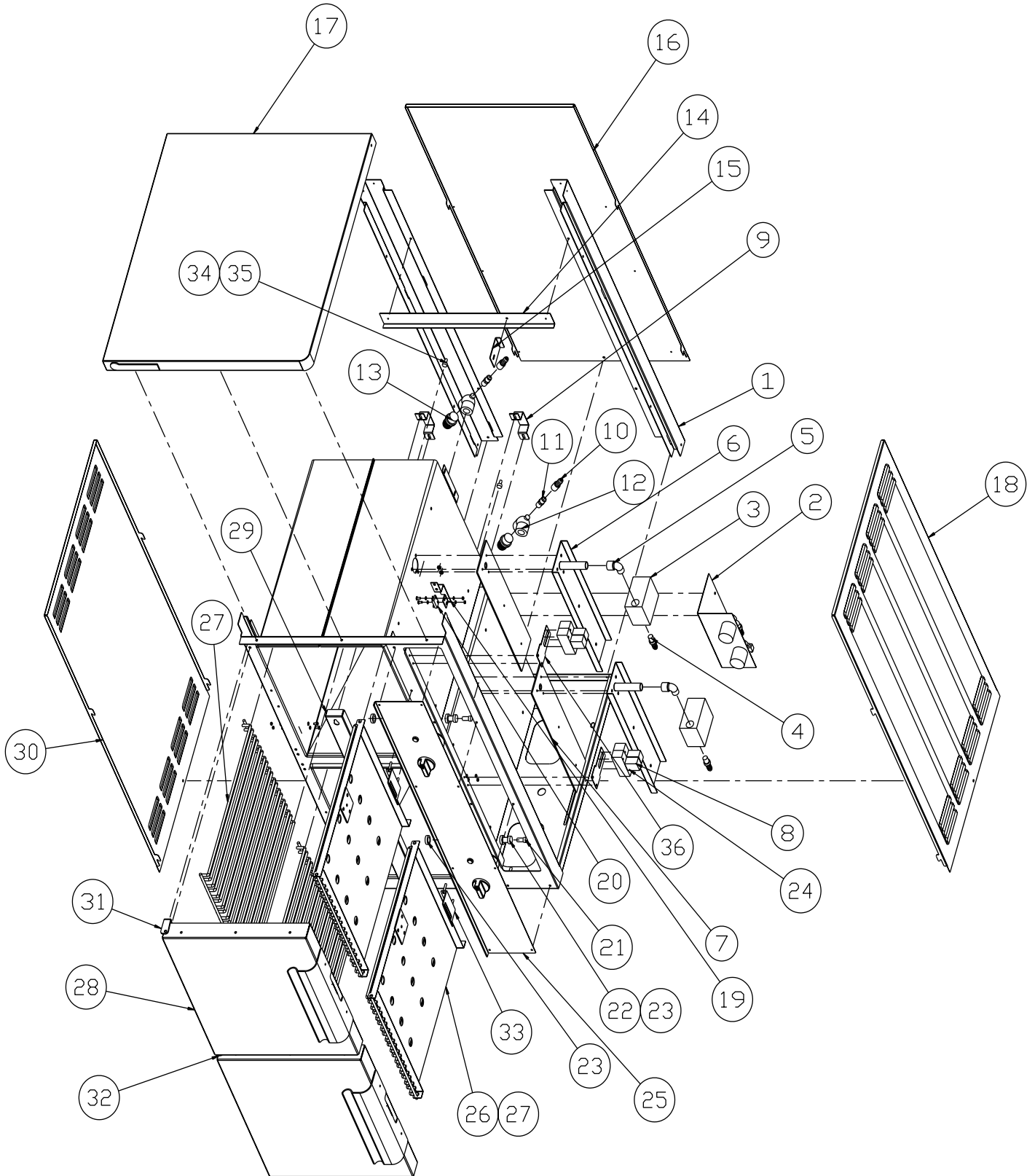

Fig. 4 Cabinet Assembly

ILLUSTRATED PARTS LIST

Fig. 4 Cabinet Assembly

ITEM	PART NO.	DESCRIPTION	QTY.
1	98-3501	POST, REAR	2
2	REF.	CONDENSER ASSY. (see Fig. 7)	1
3	10-5859	INLET SOLENOID	2
4	08-4892	BARB, 1/2" IPS x 3/8" ID TUBE	2
5	10-8823	ELBOW, STREET, 1/2" IPS	2
6	98-3510	INLET ADAPTER ASSY.	2
7	91-6838	INLET GASKET	2
8	10-9174	RELAY TUBE	2
9	91-6477	BRACKET, LINER HOLD DOWN	2
10	08-4978	BARB, 1/4" IPS FEMALE X 1/4" ID TUBE	2
11	08-4866	SPRAYER NOZZLE	2
12	08-4833	REDUCING TEE, 1" X 1" X 1/4" IPS	2
13	08-1207	BARB, 1" IPS	2
14	91-7638	STIFFENER, BACK	1
15	91-7639	BRACKET, LINER TIE	1
16	98-3503	PANEL, BACK	1
17	91-7619	PANEL, TOP	1
18	98-3505	PANEL, SIDE	2
19	91-7690	BRACKET, REED SWITCH	2
20	08-6308	REED SWITCH	2
21	10-8105	THERMOSTAT, CONDENSER	2
22	10-3739	REDUCER, 1/2" IPS X 3/8" IPS	2
23	10-4586	NUT, SEALER, 1/2" IPS	4
24	10-9175	RELAY, SOCKET	2
25	98-3511	CONTROL PANEL ASSY.	1
26	91-7697	BAFFLE, RACK SLIDE	2
27	91-5700	RACK, WIRE	4
28	91-6493	DOOR ASSY.	2
29	91-7684	STRAINER	2
30	08-4600	COMPRESSION SPRING	4
31	91-6475	HINGE, TOP	2
32	91-6476	HINGE, BOTTOM	2
33	91-6492	LATCH, RECEIVER	2
34	91-6491	GROMMET	2
35	08-6538	VACUUM BREAKER	2
36	91-6940	RELAY BRACKET	2

ILLUSTRATED PARTS LIST

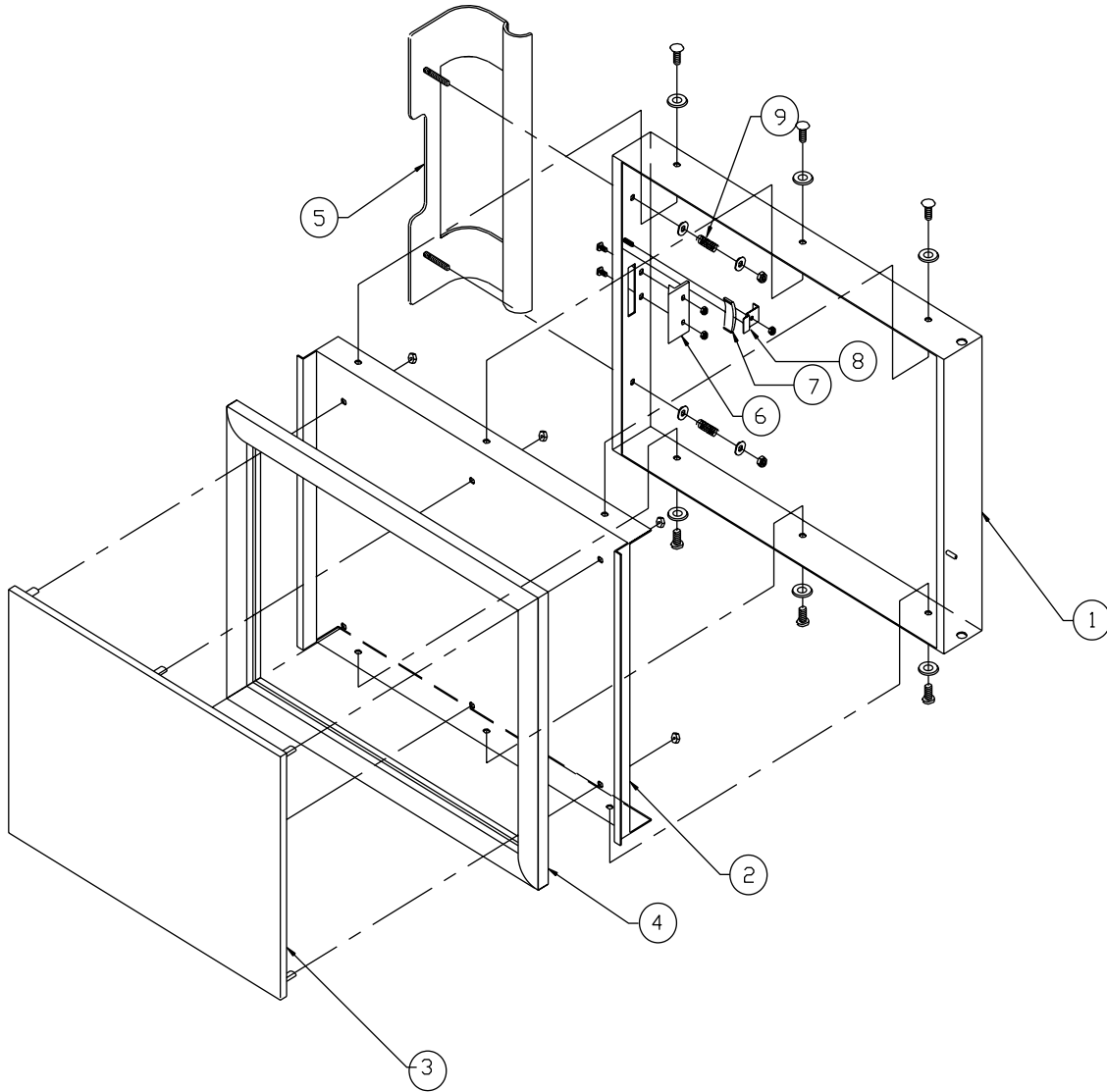

Fig. 5 Door Assembly

ITEM	PART NO.	DESCRIPTION	QTY.
1	91-5729	OUTER DOOR	1
2	91-5766	INNER DOOR	1
3	91-5731	GASKET RETAINING PLATE	1
4	91-5286	DOOR GASKET	1
5	91-5745	DOOR HANDLE	1
6	09-1608	STRIKER	1
7	08-5027	MAGNET	1
8	91-5901	MAGNET BRACKET	1
9	08-4600	COMPRESSION SPRING	2

ILLUSTRATED PARTS LIST

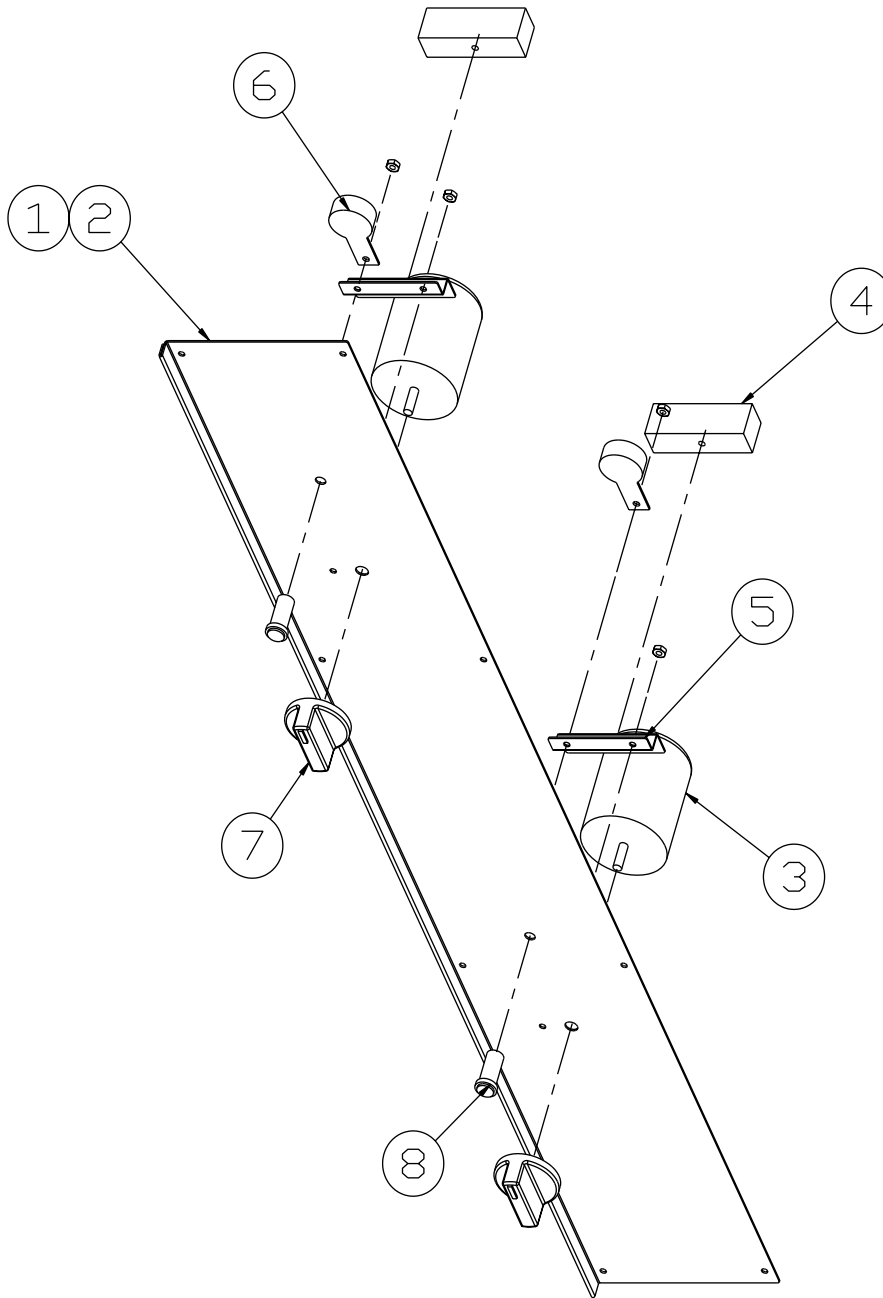

Fig. 6 Control Panel Assembly

ITEM	PART NO.	DESCRIPTION	QTY.
1	98-3504	CONTROL PANEL	1
2	98-3507	ARTWORK, CONTROL PANEL	1
3	08-6464	60 MIN. TIMER	2
4	08-6541	TERMINAL STRIP	2
5	91-6471	BRACKET, TERMINAL STRIP	2
6	10-7395	BUZZER	2
7	08-3826	KNOB, TIMER	2
8	10-5052	LIGHT, RED, ON/OFF	2

ILLUSTRATED PARTS LIST

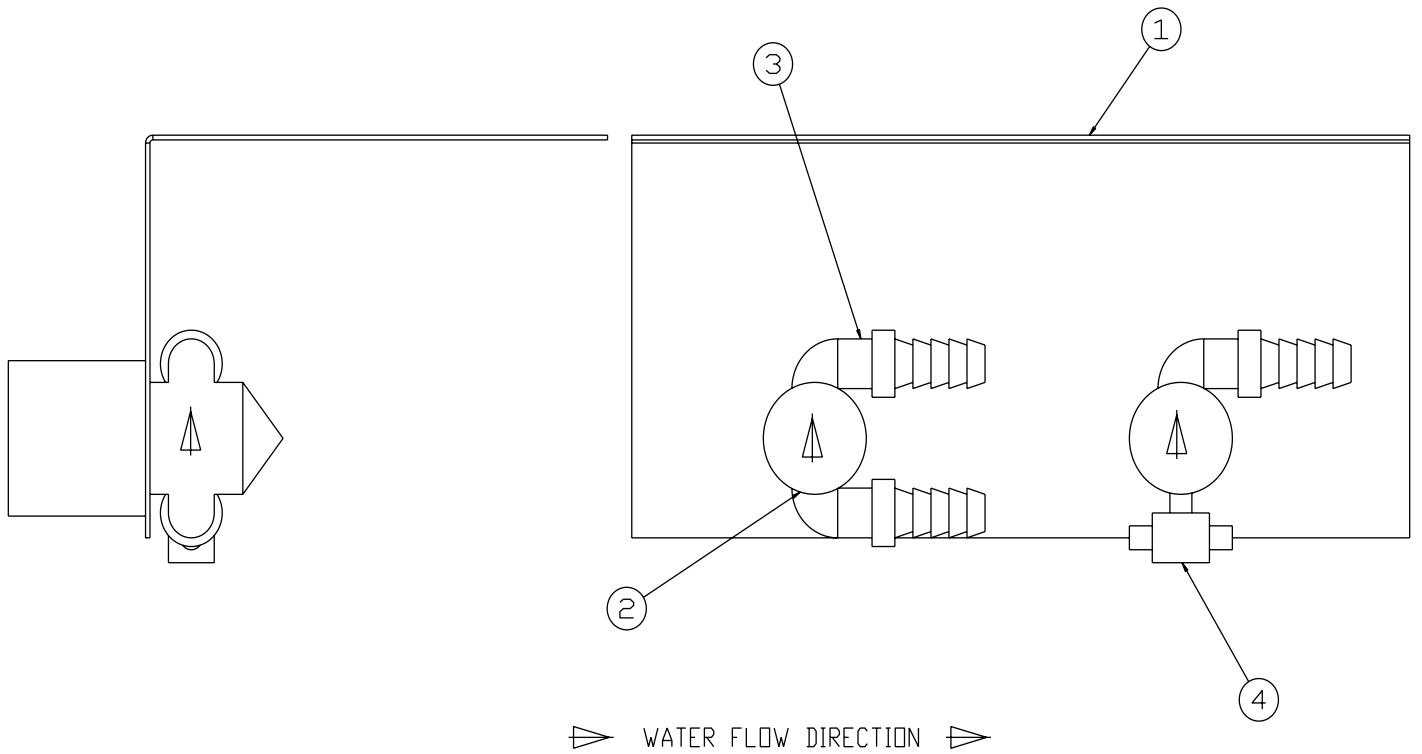

Fig. 7 Condenser Assembly

ITEM	PART NO.	DESCRIPTION	QTY.
1	91-7640	CONDENSER BRACKET	1
2	08-4821	CONDENSER SOLENOID	2
3	08-4864	HOSE BARB, 90°, 1/8" IPS	3
4	08-5009	TEE, 1/8 IPS x 1/4 ID HOSE	1

ILLUSTRATED PARTS LIST

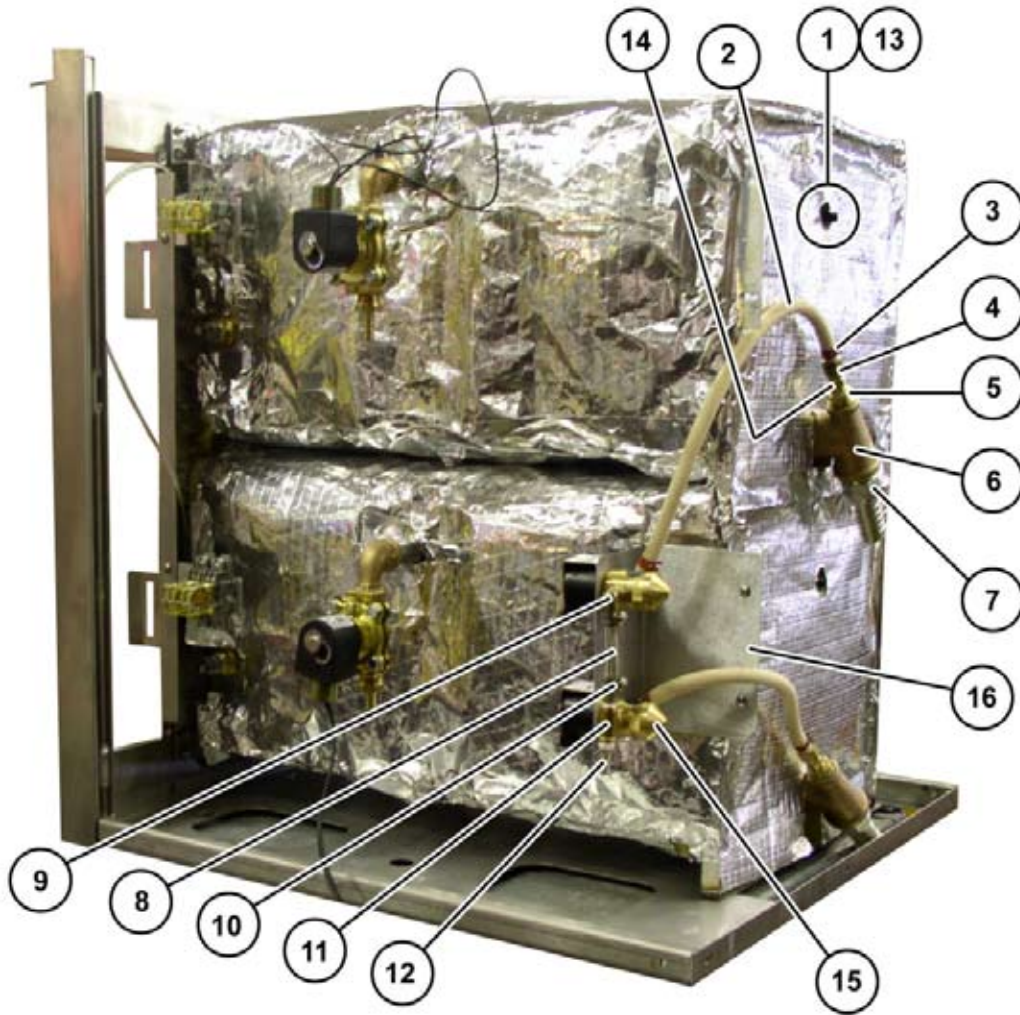

Fig. 8 Complete Condenser Assembly

ITEM	PART NO.	DESCRIPTION	QTY.
1	08-6538	3/8" CHECK VALVE	1
2	08-7970	NEOPRENE HOSE 15 1/2"	1
3	08-7975	CLAMP	2
4	08-4978	HOSE BABS	1
5	10-3539	BUSHING 1/2 x 1/4 HEX	1
6	08-5438	TEE, BRASS 1" x 1/2" X 1"	1
7	08-1207	HOSE FITTING 1" NPT	1
8	15-7208	BRAIDED STAINLESS STEEL HOSE 2 1/2"	1
9	08-4864	HOSE BARB, 90°, 1/8" IPS	2
10	08-1206	HOSE CLAMP	2
11	08-7923	TEE 1/8" NPT	1
12	08-4890	HOSE COUPLER, 1/8 IPS x 1/4 ID	2
13	91-6491	GROMMET	1
14	08-4866	SPRAY NOZZLE	1
15	08-4821	CONDENSER SOLENOID	2
16	91-7640	CONDENSER BRACKET	