



Projection Alarm Clock
with Indoor / Outdoor Thermometer and Ice Alert
Model: EW98
USER MANUAL

Thank you for your purchase of this Projection Alarm Clock. Please read these instructions carefully and keep the manual well for future reference.

The receiver unit has a clear and easy-to-read display that shows the indoor temperature, time, calendar, the maximum & minimum temperature records in the past 24 hours as well as the outdoor temperature measured and transmitted from the remote sensors. It is able to receive and display readings from up to 3 remote sensors.

The 433 MHz technology means no wire installation is required and you can place the sensors within 30m (100ft) from the main (indoor) unit.

This product is designed to synchronize its date and time automatically once it is within range of the WWVB-60 signal from the atomic clock in Fort Collins, Colorado.

OVERVIEW

RECEIVER

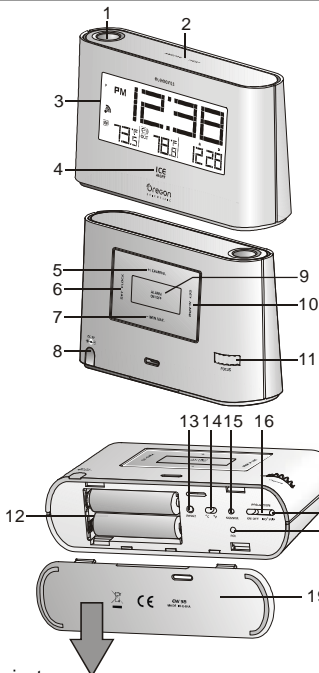

- 1. Projector:**
 - Use it to project the time and temperature.
- 2. SNOOZE/LIGHT key:**
 - In normal time mode, press it once to turn on the backlight for 5 seconds.
 - Press it to silence the current alarm when it is going and enter the snooze mode for 8 minutes.
- 3. LCD display:**
 - Displays time, indoor & outdoor temperature, date.
- 4. Ice alert indicator light:**
 - Flashes when the outdoor temperature is between -2.0°C(28 °F) and 3.0°C(37 °F).
- 5. +/-CHANNEL key:**
 - Press it once to switch between Channel 1, 2 and 3.
 - Press and hold it for 2 seconds to view the channels automatically. Press it again to exit the automatic display mode.
 - In time setting mode, press it to increase the setting values.
- 6. SET CLOCK key:**
 - In normal time mode, press it once to enter the normal time setting mode.
 - In normal time setting mode, press it to step the setting items. Press and hold it to exit the setting mode in any step.
- 7. -/MIN.MAX. key:**
 - Press it to show the minimum and maximum temperature records in the past 24 hours.
 - Press and hold it for 3 seconds to delete the minimum and maximum temperature records.
 - In time setting mode, press it to decrease the setting values.
- 8. DC jack:**
 - Plug DC adaptor to power the clock.
- 9. ALARM ON/OFF key:**
 - Press it once to turn on the backlight and display

- the alarm time for 5 seconds.
 - Press it again to turn on/off the alarm.
- 10. SET ALARM key:**
 - Press it once to turn on the backlight for 5 seconds, and press it again to enter the alarm time setting mode.
 - In alarm time setting mode, press it to step the setting items.
 - 11. FOCUS turning knob:**
 - Focus the projected image.
 - 12. BATTERY COMPARTMENT:**
 - Accommodates 2 AA size batteries.
 - 13. RESET key:**
 - Press it to return all values to default values.
 - In case of malfunction, the unit may be required to reset.
 - 14. °C/°F slide switch:**
 - Slide it to switch between Celsius and Fahrenheit.
 - 15. SENSOR key:**
 - Press it once to turn on the reception of transmitter signal (433 MHz).
 - During the reception period, press and hold it for 3 seconds to stop the reception.
 - 16. PROJECTION ON/OFF slide switch:**
 - Slide it to turn on/off the projector.
 - 17. 180° FLIP key:**
 - Press it to rotate the projected image by 180°.
 - 18. RCC key:**
 - In normal time mode, press it once to receive the RC signal for reception testing.

BATTERY DOOR

LCD DISPLAY

- Time zone
- Low battery indicator
- Signal reception indicator
- Indoor temperature
- Channel
- Sensor signal
- Outdoor temperature
- °C & °F
- Alarm time & Date
- Min and Max temperature
- Time

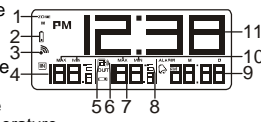

SENSOR

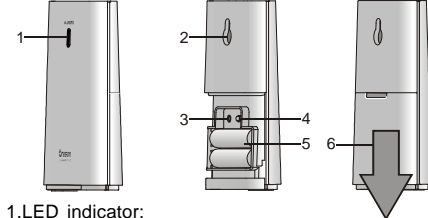

- 1. LED indicator:**
 - Flashes when the remote unit sensor a reading.
- 2. Wall-mounting holder:**
 - Supports the sensor on the wall.
- 3. RESET key:**
 - Press it to restart the sensor and return all values to default values.
- 4. CHANNEL slide switch:**
 - Assign the sensor to channel 1, 2 or 3.
- 5. BATTERY COMPARTMENT:**
 - Accommodates 2 AAA size batteries.
- 6. BATTERY DOOR**

RECEPTION OF SENSOR SIGNAL

OPERATING THE MAIN UNIT

- Remove the battery door and insert 2 new AA size batteries as per the polarity information marked on the battery compartment.
- Press "RESET" key to restart the clock.
- Slide "°C/°F" switch to select between Celsius and Fahrenheit.
- Slide the battery door back on.
- Press "+/CHANNEL" key to select the desired channel.

	Main unit is searching for the sensor(s) (the icon will be flashing)
	The sensor(s) cannot be found
	Sensor 1 has been found (the icon will be displayed, but won't flash)
	The sensor(s) cannot be found after operating the main unit for 15 minutes

Note When the sensor signal is received, the icon "📶" will be displayed on the LCD.

OPERATING THE SENSOR

- Remove the battery door and slide "CHANNEL" switch to CH 1. (When using additional sensors, make sure each sensor is assigned a different CHANNEL number.
- Insert 2 new AAA batteries, matching polarities (+/-).
- Press the "RESET" key .
- Slide the battery door back on.

Note

- Place the sensor in location away from direct sunlight and rain.
- Do not place the sensor more than 30 m (100 ft) from the main (indoor) unit.
- Position the sensor so that it faces the main (indoor) unit, minimizing obstructions such as doors, walls, and furniture.
- Place the sensor in a location with a clear view to the sky, away from metallic or electronic objects.
- Position the sensor closer to the main unit during cold winter months as below-freezing temperatures may affect battery performance and signal transmission.

The transmission range may vary depending on many factors. You may need to experiment with various locations to get the best results.

Standard Alkaline batteries contain significant amounts of water. Because of this they will freeze in low temperatures of approximately -12°C (10°F). Disposable Lithium batteries have a much lower threshold for temperature with an estimated freezing range of below -30°C (-22°F).

Wireless ranges can be impacted by a variety of factors such as extremely cold temperatures. Extreme cold may temporarily reduce the effective range between the sensor and the base station. If the unit's performance fails due to low temperature, the unit will resume proper functioning as the temperature rises to within the normal temperature range (i.e. no permanent damage will occur to the unit due to low temperatures).

RECEPTION OF RADIO CONTROLLED TIME SIGNAL

The time and calendar are radio-controlled. The current time and calendar are automatically synchronized with the atomic clock signal from Fort Collins, Colorado. When used for the first time (after inserting batteries or pressing "RESET" key), the clock will start to search for the atomic clock signal and the signal reception icon will flash for 5 minutes.

SIGNAL RECEPTION INDICATOR

The wave segment flashing means time signals are being received. The signal quality could be classified into 3 types:



Note

- The unit will automatically search for the time signal at 2:00am (3:00am or 4:00am is also available if the signal is not received at 2:00am), 8:00am, 2:00pm, and 20:00 each day.
- Always place the unit away from electrical devices such as televisions, computers, telephones, etc.
- Avoid placing the unit on or next to metal plates.
- If possible, place the unit next to a window. Signal reception is greatly decreased when located in closed areas like basements or metal buildings.
- Do not start reception in moving vehicles or trains.

TIME AND CALENDAR MANUAL SETTING

If you are out of reach of the Radio Controlled transmitter or if the reception is not reachable, the time and calendar can be set manually. As soon as the signal of transmitter is received again, the clock will automatically synchronize with the exact time and calendar.

- In normal time mode, press "SET CLOCK" key once to enter the time setting mode.
- Press "+/CHANNEL" or "-/MIN.MAX." key to change the settings.
- Press "SET CLOCK" to confirm. The setting order is: 12/24-hr format, time, time zone offset, year, day/month format, date.
- Press "SET CLOCK" key to save and exit the setting mode.

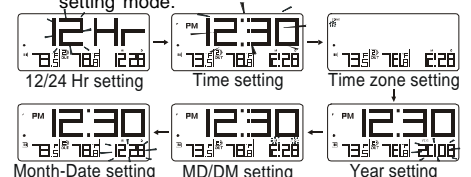

Note

- During the setting period, press and hold "+/CHANNEL" or "-/MIN.MAX." key to speed up the change of settings.
- The time zone indicators are abbreviated as below: P=Pacific, M=Mountain, C=Central, E=Eastern.

ALARM TIME SETTING

- In normal time mode, press "SET ALARM" key once to enter the alarm time setting mode.
- Press "+/CHANNEL" or "-/MIN.MAX." key to set hour/minute.
- Press "SET ALARM" key to save and exit the setting mode "A" indicates alarm is ON.

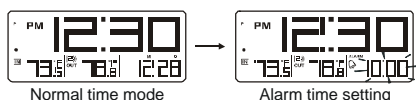

Normal time mode

Alarm time setting

Note

- The alarm will be automatically turned on when you set the alarm time.
- During the alarm time setting period, press and hold "+/CHANNEL" or "-/MIN.MAX." key to speed up the change of settings.

USING ALARM FUNCTION

- Follow the directions above to set the alarm time.
- In normal time mode, press "ALARM ON/OFF" key once to display the current alarm time.
- Press it again to turn alarm ON/OFF.

TO SILENCE THE ALARM

- Press "SNOOZE/LIGHT" to silence the alarm for 8 minutes. The "A" will be flashing.
- Press any other key to turn the alarm off and activate it again after 24 hours.
- If no key is pressed within 120 seconds, the alarm will be turned off and be activated again after 24 hours.

USING THE PROJECTOR

Slide the "PROJECTION ON/OFF" switch to turn on/off the projection light. The projection light must be on a dark background and within 1-4 meters (3 to 12 feet) from the clock, see example below:

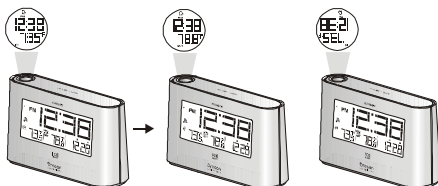

Note

- Slide "PROJECTION ON/OFF" to turn on the projection function.
- Press "SNOOZE/LIGHT" to turn on the projector for 5 seconds.
- When using DC power adapter, the projector will be turned on all the time.
- The indoor and outdoor temperature will be projected alternatively for 5 seconds.
- If the alarm is set to go off, the alarm icon "A" will be projected.
- Press "180 FLIP" to rotate the projected image by 180°.
- Turn "FOCUS" knob to focus the projected image.

READING INDOOR AND OUTDOOR TEMPERATURE RECORDS

Slide "°C/°F" switch to select between Celsius and Fahrenheit.

Note

- If no signals are received or the transmission is interfered, "--" will appear on the display.
- Replace the batteries if the batteries are low, relocate the sensor or main display unit away from electronic devices, or hit the reset buttons on the main display unit and sensor.

VIEWING THE MINIMUM AND MAXIMUM TEMPERATURE RECORDS

- In normal mode, press "-/MIN.MAX." key twice to show the minimum indoor & outdoor temperature records in the past 24 hours.
- Press it again to show the maximum temperature records.
- Press it again to exit.

Note Press and hold it for 3 seconds to delete the minimum and maximum temperature records.

MAX.temperature records MIN.temperature records



USING ICE ALERT FUNCTION

If the outdoor temperature range is -2.0°C ~ 3.0°C (28.4°F ~ 37.4°F), the ice alert indicator light will be turned on and flash.

BATTERY REPLACEMENT

If the low battery icon turns on next to the outdoor temperature reading, replace the sensor's battery with 2 AAA batteries.

If the low battery icon turns on next to time, replace the main unit's battery with 2 new AA batteries.

Low battery indicator



Note

Attention! Please dispose of the used unit or batteries in an ecologically safe manner.

PLACEMENT OF MAIN UNIT AND SENSOR

For the sensor, place the screw on the desired wall and hang the sensor by the recessed hole in the back of it or simply place it on the desktop. For the main unit, you can just place it on the table by itself.

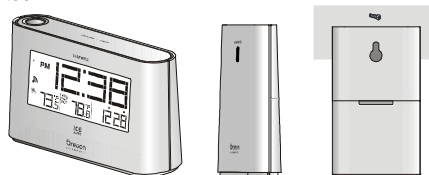

SPECIFICATIONS

TYPE	DESCRIPTION
MAIN UNIT	
L x W x H	138 x 42 x 82 mm (5.43 x 1.65 x 3.23 in)
Weight	196g
Signal frequency	433 MHz
Temperature range	-5°C to 50°C (23°F to 122°F)
Temperature resolution	0.1°C (0.2°F)
Ice alert temperature range	3°C to -2°C (37°F to 28°F)
Power	2 x AA 1.5V batteries
REMOTE UNIT (EW-99)	
L x W x H	58 x 23 x 100 mm (2.28 x 0.9 x 3.94 in)
Weight	52g
Signal frequency	433 MHz
Number of channel	3
Transmission range	30 m (98 ft) unobstructed
Temperature range	-20°C to 60°C (-4°F to 140°F)
Power	2 x AAA 1.5V batteries

Note We recommend that you use alkaline batteries with this product for longer usage and lithium batteries in temperatures below freezing.

PRECAUTIONS

- Do not subject the unit to excessive force, shock, dust, temperature or humidity.
- Do not cover the ventilation holes with any items such as newspapers, curtains etc.
- Do not immerse the unit in water. If you spill liquid over it, dry it immediately with a soft, lint-free cloth.
- Do not clean the unit with abrasive or corrosive materials.
- Do not tamper with the unit's internal components. This invalidates the warranty.
- Only use fresh batteries. Do not mix new and old batteries.
- Images shown in this manual may differ from the actual display.
- When disposing of this product, ensure it is

collected separately for special treatment and not as normal household waste.

- Placement of this product on certain types of wood may result in damage to its finish for which Oregon Scientific will not be responsible. Consult the furniture manufacturer's care instructions for information.
- The contents of this manual may not be reproduced without the permission of the manufacturer.
- Do not dispose old batteries as unsorted municipal waste. Collection of such waste separately for special treatment is necessary.
- Please note that some units are equipped with a battery safety strip. Remove the strip from the battery compartment before first use.

Note The technical specifications for this product and the contents of the user manual are subject to change without notice.

ABOUT OREGON SCIENTIFIC

Visit our website (www.oregonscientific.com) to learn more about Oregon Scientific products. If you're in the US and would like to contact our Customer Care department directly, please visit: www2.oregonscientific.com/service/support

For international inquiries, please visit: www2.oregonscientific.com/about/international

FCC STATEMENT

This device complies with Part 15 of the FCC Rules. Operation is subject to the following two conditions: (1) This device may not cause harmful interference, and (2) This device must accept any interference received, including interference that may cause undesired operation.

WARNING Changes or modifications to this unit not expressly approved by the party responsible for compliance could void the user's authority to operate the equipment.

Note This equipment has been tested and found to comply with the limits for a Class B digital device, pursuant to Part 15 of the FCC Rules. These limits are designed to provide reasonable protection against harmful interference in a residential installation.

This equipment generates, uses and can radiate radio frequency energy and, if not installed and used in accordance with the instructions, may cause harmful interference to radio communications. However, there is no guarantee that interference will not occur in a particular installation. If this equipment does cause harmful interference to radio or television reception, which can be determined by turning the equipment off and on, the user is encouraged to try to correct the interference by one or more of the following measures:

- Reorient or relocate the receiving antenna.
- Increase the separation between the equipment and receiver.
- Connect the equipment into an outlet on a circuit different from that to which the receiver is connected.
- Consult the dealer or an experienced radio / TV technician for help.

DECLARATION OF CONFORMITY

The following information is not to be used as contact for support or sales. Please visit our website at www2.oregonscientific.com/service/support for all inquiries.

We
Name: Oregon Scientific, Inc.
Address: 19861 SW 95th Ave., Tualatin, Oregon 97062 USA
Telephone No.: 1-800-853-8883

Declare that the product

Product No.: EW98
Product Name: Projection Alarm Clock with Indoor / Outdoor Thermometer and Ice Alert
Manufacturer: IPM Concepts Limited
Address: Block C, 9/F, Kaiser Estate, Phase 1, 41 Man Yue St., Hung Hom, Kowloon, Hong Kong

is in conformity with Part 15 of the FCC Rules. Operation is subject to the following two conditions:

- This device may not cause harmful interference.
- This device must accept any interference received, including interference that may cause undesired operation.