

Pneumatic Brad Nailer

MODEL AF501

INSTRUCTION MANUAL

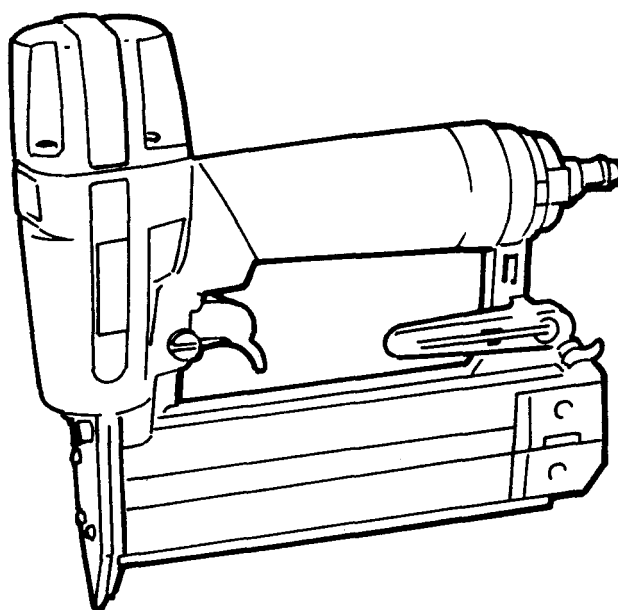

SPECIFICATIONS

Air pressure	Applicable length (Brad nails)	Nail capacity	Min. hose diameter	Dimensions (L x W x H)	Net weight
4 – 7 kgf/cm ² G (60 – 100 PSIG)	25 mm, 30 mm, 35 mm, 40 mm, 45 mm, 50 mm (1", 1-3/16", 1-3/8", 1-9/16", 1-3/4", 2")	100 pcs.	6.5 mm (1/4")	246 mm x 57 mm x 225 mm (9-11/16" x 2-1/4" x 8-7/8")	1.26 kg (2.78 lbs)

* Manufacturer reserves the right to change specifications without notice.

* Note: Specifications may differ from country to country.

IMPORTANT SAFETY INSTRUCTIONS

WARNING: WHEN USING THIS TOOL, BASIC SAFETY PRECAUTIONS SHOULD ALWAYS BE FOLLOWED TO REDUCE THE RISK OF PERSONAL INJURY, INCLUDING THE FOLLOWING:

READ ALL INSTRUCTIONS.

- For personal safety and proper operation and maintenance of the tool, read this instruction manual carefully before using the tool.

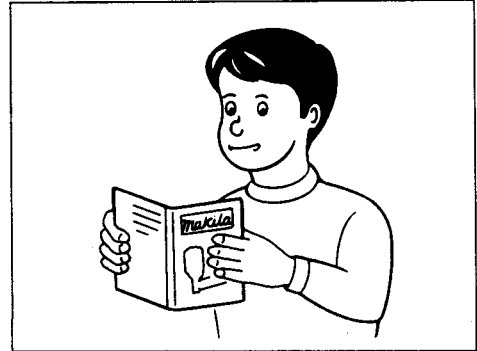

- Wear light but not loose clothing. Sleeves should be buttoned or rolled up. No necktie should be worn.

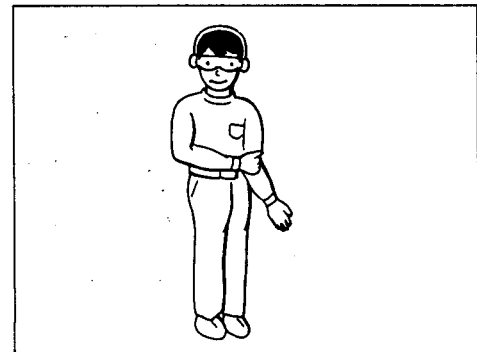

- Always wear safety glasses to protect your eyes from dust or nail injury. The safety glasses should conform with the requirements of ANSI Z87. 1 — 1979. Also wear hearing protection to protect your ears against exhaust noise.

WARNING:

It is an employer's responsibility to enforce the use of safety eye protection equipment by the tool operators and by other persons in the immediate working area.



- Rushing the job or forcing the tool is dangerous. Handle the tool carefully. Do not operate when under the influence of alcohol, drugs or the like.

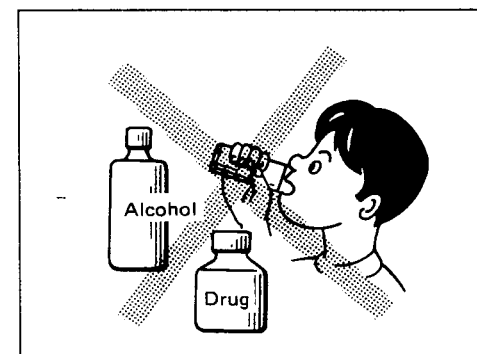

• **General Tool Handling Guidelines:**

1. Always assume that the tool contains fasteners.
2. Do not point the tool toward yourself or anyone whether it contains fasteners or not.
3. Never depress the operating control unless the nosepiece of the tool is directed toward the workpiece.
4. Respect the tool as a working implement.
5. No horseplay.

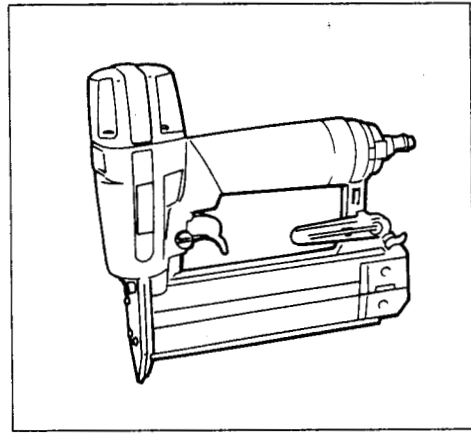

- Sparks sometimes fly when the tool is used. Do not use the tool near volatile, flammable materials such as gasoline, thinner, paint, gas, adhesives, etc.; they will ignite and explode, causing serious injury.

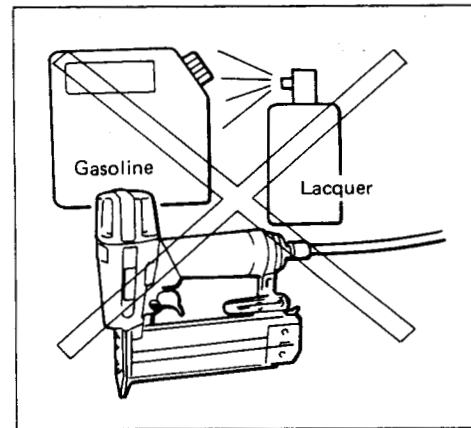

- The area should be sufficiently illuminated to assure safe operations. The area should be clear and litter-free. Be especially careful to maintain good footing and balance.

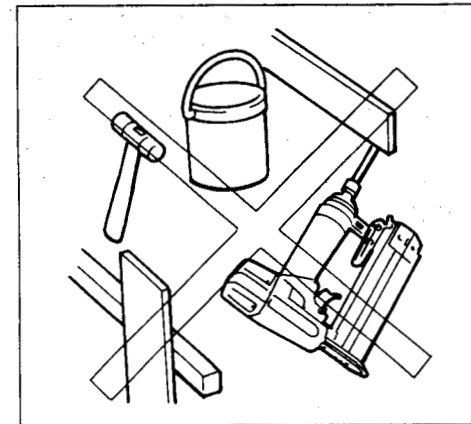

- Only those involved in the work should be in the vicinity. Children especially must be kept away at all times.

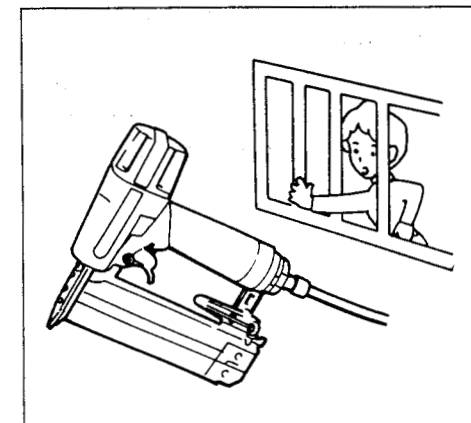

- There may be local regulations concerning noise which must be complied with by keeping noise levels within prescribed limits. In certain cases, shutters should be used to contain noise.

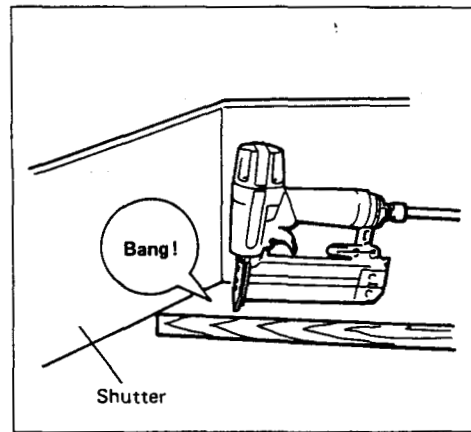

- Do not tamper with the tool or attempt to use it for other than nailing.

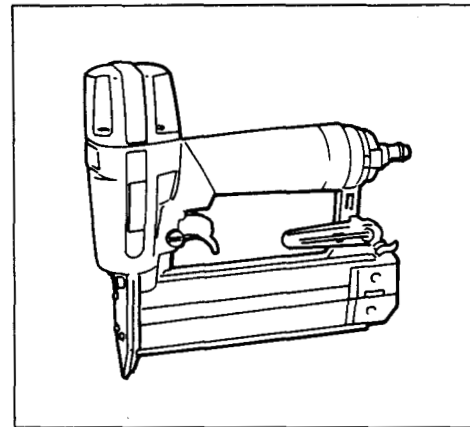

- Operate the tool within the specified air pressure of 4.0 – 7.0 kgf/cm²G (60 – 100 PSIG) for safety and longer tool life. Do not exceed the recommended max. operating pressure of 7 kgf/cm²G (100 PSIG). The tool should not be connected to a source whose pressure potentially exceeds 14.0 kgf/cm²G (200 PSIG).

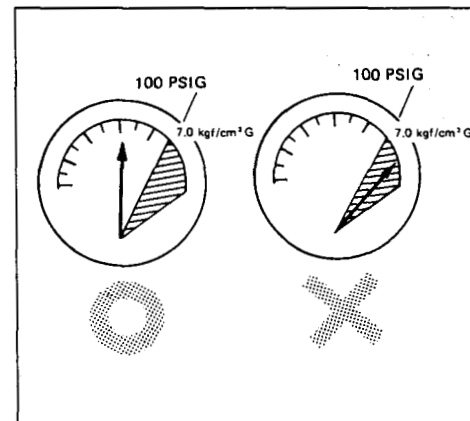

- Never use the tool with other than compressed air. If high-pressure gas (carbon dioxide, oxygen, nitrogen, hydrogen, propane, acetylene, etc.) is used as a power source for this tool, the tool will explode and cause serious injury.

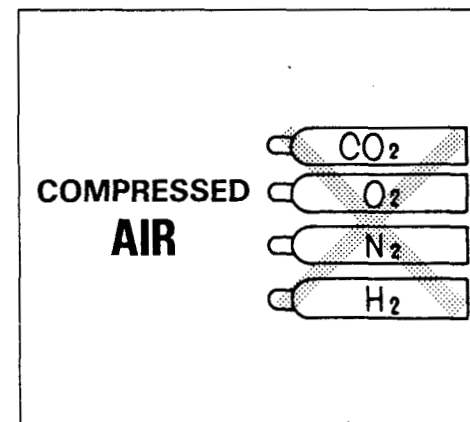

- Always check the tool for its overall condition and loose screws before operation. Tighten as required.

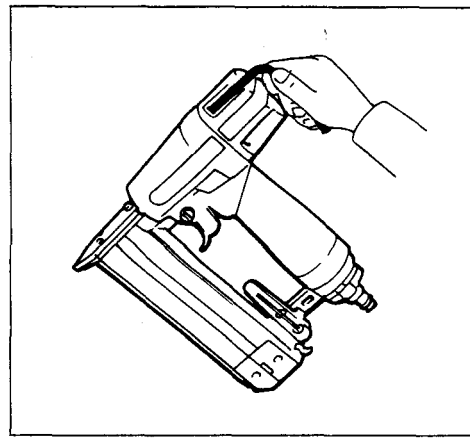

- Make sure the safety mechanism is in working order before operation. First, disconnect the hose from the tool and open the magazine. Turn the lock knob (lock pin) to make sure the trigger is locked and released alternately with every quarter turn of the lock knob (lock pin).

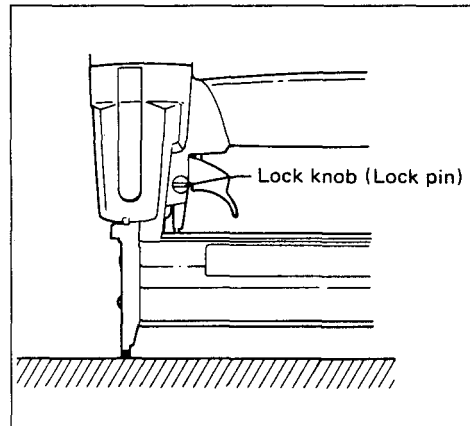

- Check walls, ceilings, floors, roofing and the like carefully to avoid possible electrical shock, gas leakage, explosions, etc. caused by striking lives wires, conduits or gas pipes.

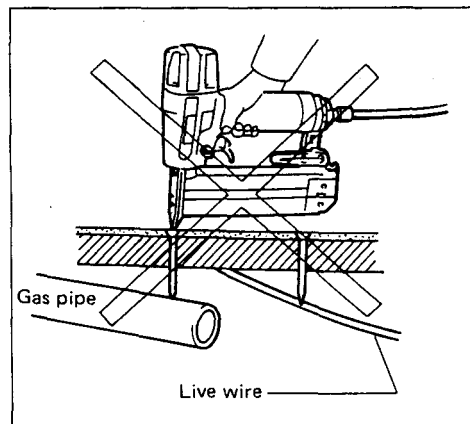

- Use only nails specified in this manual. The use of any other nails may cause malfunction of the tool.

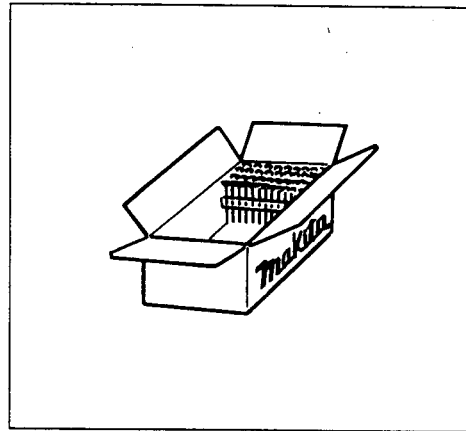

- Do not permit those uninstructed to use the tool.

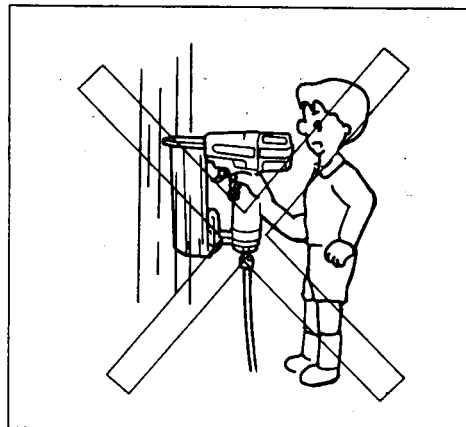

- Make sure no one is nearby before nailing. Never attempt to nail from both the inside and outside at the same time. Nails may rip through and/or fly off, presenting a grave danger.

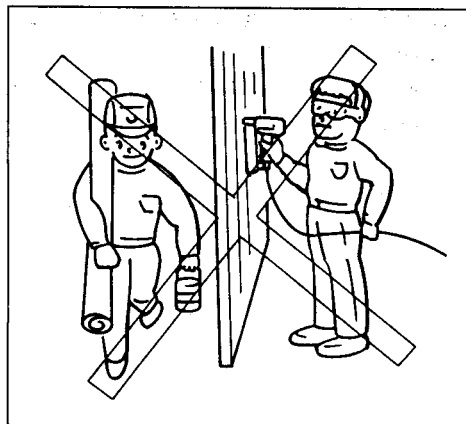

- Watch your footing and maintain your balance with the tool. Make sure there is no one below when working in high locations, and secure the air hose to prevent danger if there is sudden jerking or catching.

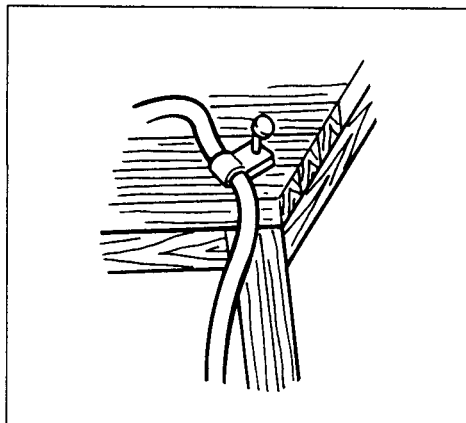

- On rooftops and other high locations, nail as you move forward. It is easy to lose your footing if you nail while inching backward. When nailing against perpendicular surface, nail from the top to the bottom. You can perform nailing operations with less fatigue by doing so.

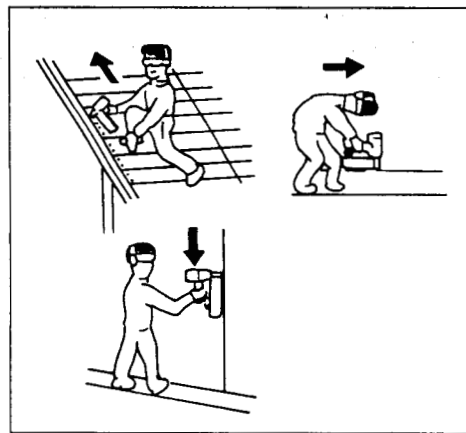

- A nail will be bent or the tool can become jammed if you mistakenly nail on top of another nail or strike a knot in the wood. The nail may be thrown and hit someone, or the tool itself can react dangerously. Place the nails with care.

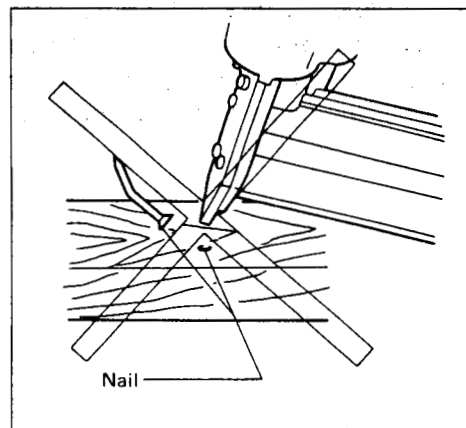

- Do not leave the loaded tool or the air compressor under pressure for a long time out in the sun. Be sure that dust, sand, chips and foreign matter will not enter the tool in the place where you leave it setting.

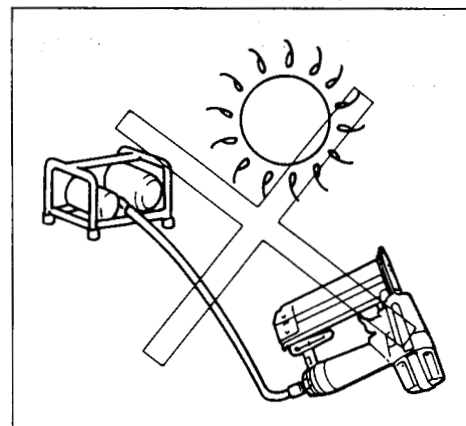

- Do not point the ejection port at anyone in the vicinity. Keep hands and feet away from the ejection port area.

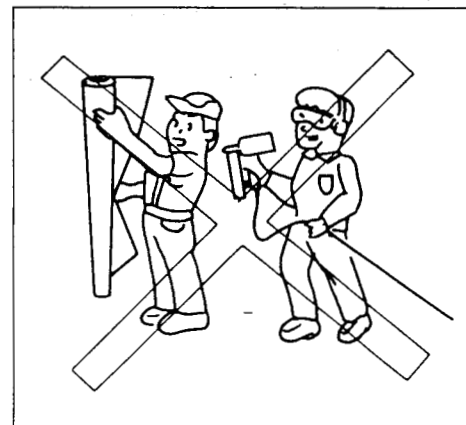

- When the air hose is connected, do not carry the tool with your finger on the trigger or hand it to someone in this condition. Accidental firing can be extremely dangerous.

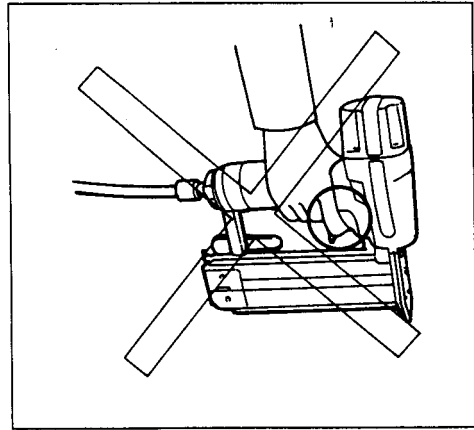

- Handle the tool carefully as there is high pressure inside the tool that can be dangerous if a crack is caused by rough handling (dropping or striking). Do not attempt to carve or engrave on the tool.

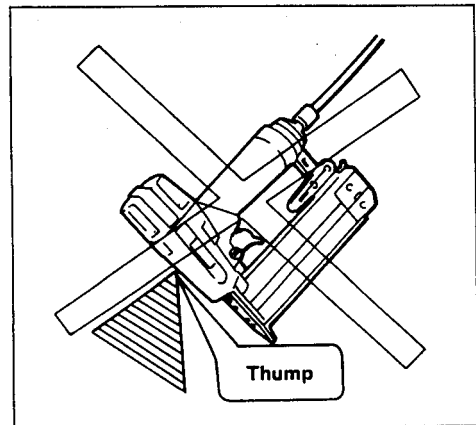

- Stop nailing operations immediately if you notice something wrong or out of the ordinary with the tool.

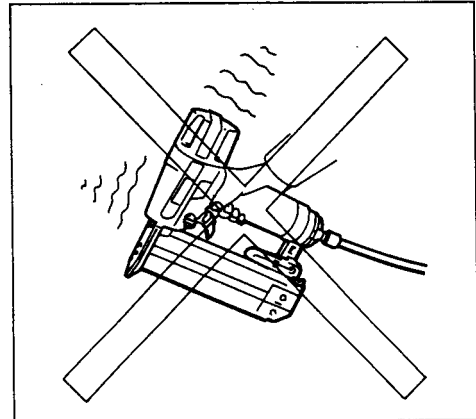

- Always lock the trigger, disconnect the air hose and remove all of the nails before inspection, maintenance, relocating, or after operation is over.

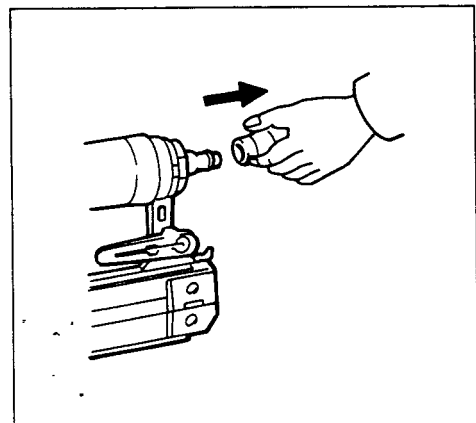

- Perform cleaning and maintenance right after finishing the job. Keep the tool in tip-top condition. Lubricate moving parts to prevent rusting and minimize friction related wear. Wipe off all dust from the parts.

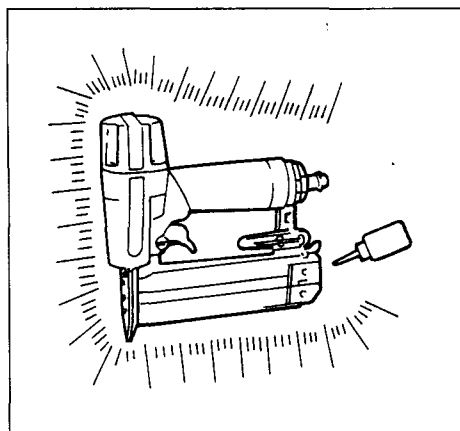

- When not operating the tool, always lock the trigger by turning the lock knob (lock pin).

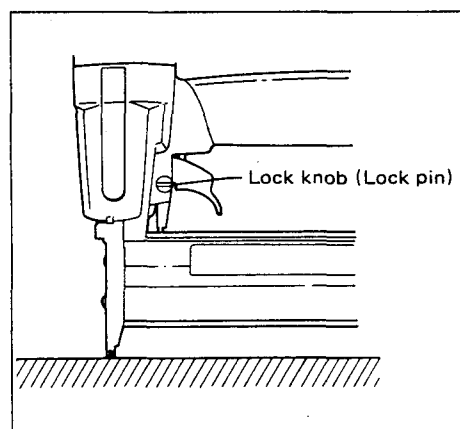

- This trigger operated tool is intended for use only when a work contacting element is not practical due to the requirements of the application. Extreme caution must be maintained not to point the nosepiece of the tool in any unsafe direction. It must be firmly held against only an intended and substantial workpiece.

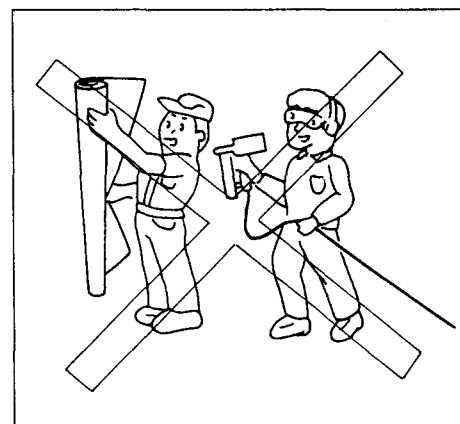

- Ask Makita's Factory or Authorized service center for periodical inspection of the tool.

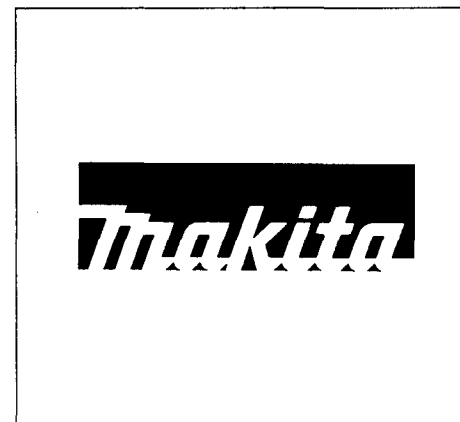

SAVE THESE INSTRUCTIONS.

TOOL INSTALLATION INSTRUCTIONS AND USE

Lubrication

To insure maximum performance, install an air set (oiler, regulator, air filter) as close as possible to the tool. Adjust the oiler so that one drop of oil will be provided for every 50 nails.

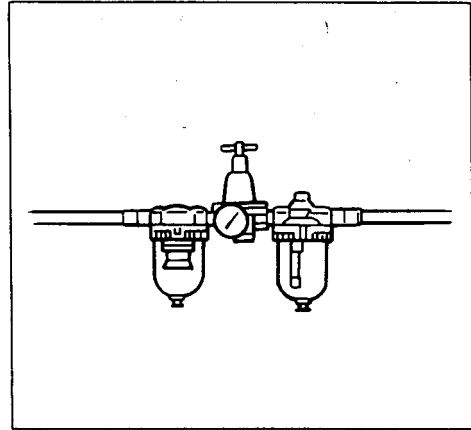

When an air set is not used, oil the tool with pneumatic tool oil by placing 2 (two) or 3 (three) drops into the air fitting. This should be done before and after use. For proper lubrication, the tool must be fired a couple of times after pneumatic tool oil is introduced.

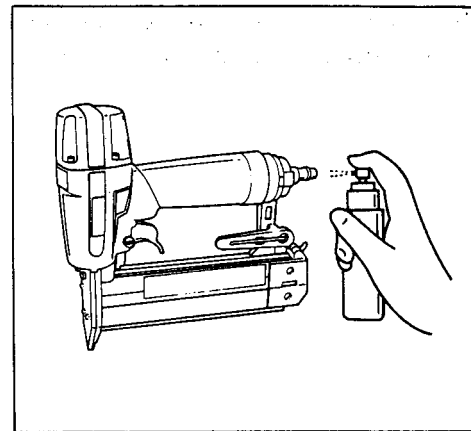

Loading nailer

CAUTION:

Always lock the trigger by turning the lock knob (lock pin) 90° and disconnect the hose before loading the nailer.

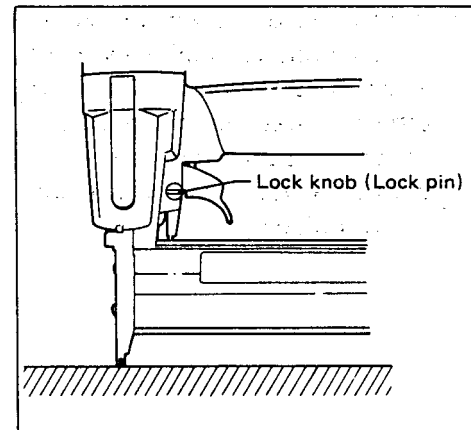

To open the slide door, pull the door knob toward you while pushing up the leaf spring.

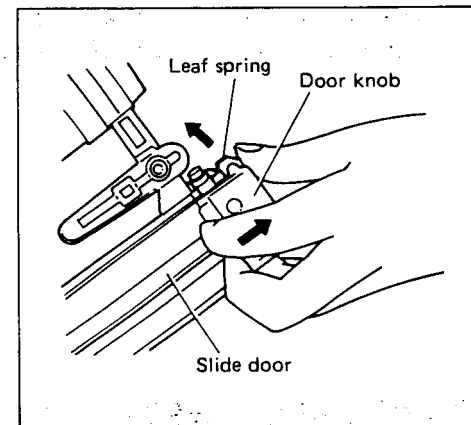

Load nails into the magazine so that the nail points will be set into the groove at the bottom of the magazine. Move the nails into the ejection slot as far as they will go.

CAUTION:

Always load the same type and size of nail into the magazine. If you load the tool with different types and/or sizes at the same time, a malfunction may result.

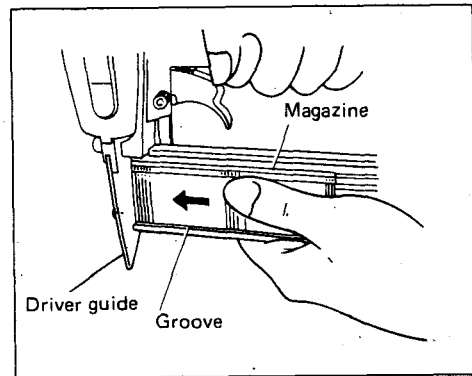

To close the slide door, slide it toward the driver guide until the slide door is locked by the leaf spring.

Adjusting depth of nailing

CAUTION:

Always lock the trigger and disconnect the hose before adjusting the depth of nailing.

The depth of nailing can be adjusted by moving the driver guide up or down. When moving the driver guide to the higher position, you can obtain a deeper depth of nailing; when moving it to a lower position, you can obtain the shallower depth of nailing. To adjust the depth of nailing, proceed as follows:

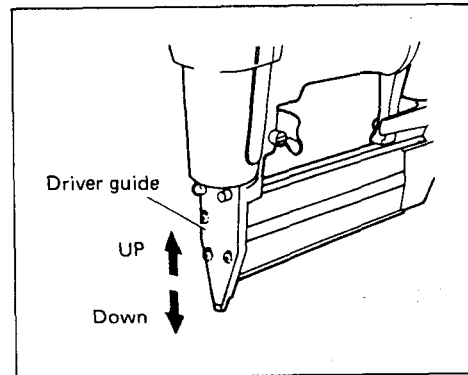

1. Remove hex wrench 3 from the hook.

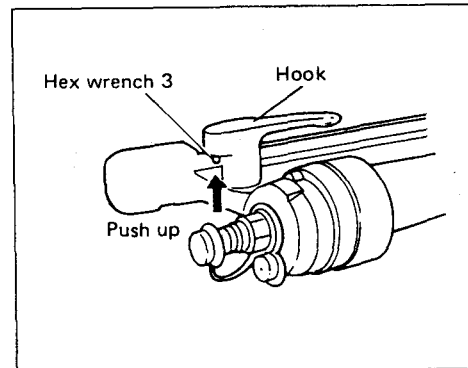

2. Turn the adjusting bolt with hex wrench 3 until the adjusting bolt contacts the projection of the center plate.

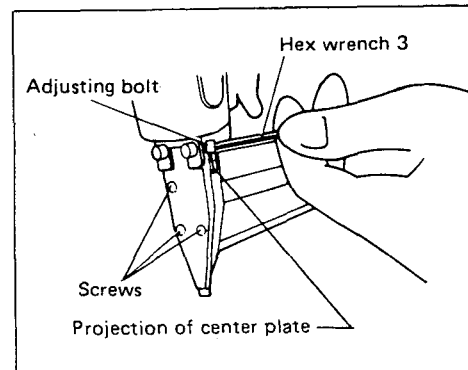

3. Loosen the three screws which secure the driver guide a half turn.
4. Turn the adjusting bolt until the desired depth of nailing can be obtained. The adjusting bolt moves 0.7 mm (1/32") per turn.
5. Tighten the three screws while holding the driver guide so that the projection of the center plate contacts the adjusting bolt.
6. If nails are driven too deep even when the driver guide is set at the lowest position, decrease the air pressure. If nails cannot be driven deep enough even when the driver guide is set at the highest position, increase the air pressure.

Nose adapter

CAUTION:

Always lock the trigger and disconnect the hose before installing or removing the nose adapter.

To prevent the workpiece from being damaged or scratched, attach the nose adapter to the end of the driver guide.

When not using it, store it in either storage cavity in the inlet cap.

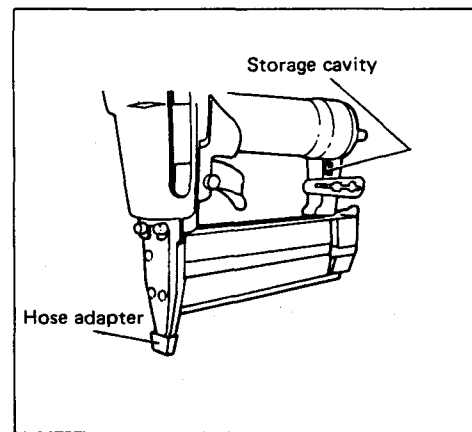

Selecting compressor

The air compressor must comply with the requirements of ANSI B19.3 – 1981.

Select a compressor that has ample pressure and air output to assure cost-efficient operation. The graph shows the relation between nailing frequency, applicable pressure and compressor air output. Thus, for example, if nailing takes place at a rate of approximately 50 times per minute at a compression of 6 kgf/cm² G (85 PSIG), a compressor with an air output over 29 liters/minute is required. Pressure regulators must be used to limit air pressure to the rated pressure of the tool where air supply pressure exceeds the tool's rated pressure. Failure to do so may result in serious injury to tool operator or persons in the vicinity.

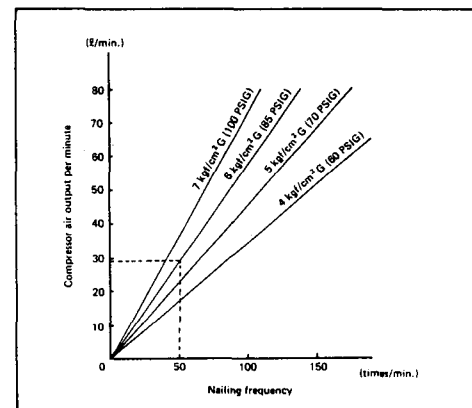

Selecting air hose

Use an air hose as large and as short as possible to assure continuous, efficient nailing operation. An air hose with an internal diameter of over 6.5 mm (1/4") and a length of less than 20 m (6.6 ft.) is recommended. Air supply hoses shall have a minimum working pressure rating of 10.7 kgf/cm² G (150 PSIG) or 150 percent of the maximum pressure produced in the system whichever is higher.

CAUTION:

Low air output of the compressor, or a long or smaller diameter air hose in relation to the nailing frequency may cause a decrease in the driving capability of the tool.

Connecting air hose

Lock the trigger. Slip the air socket of the air hose onto the air fitting on the nailer. Be sure that the air socket locks firmly into position when installed onto the air fitting. A hose coupling must be installed on or near the tool in such a way that the pressure reservoir will discharge at the time the air supply coupling is disconnected.

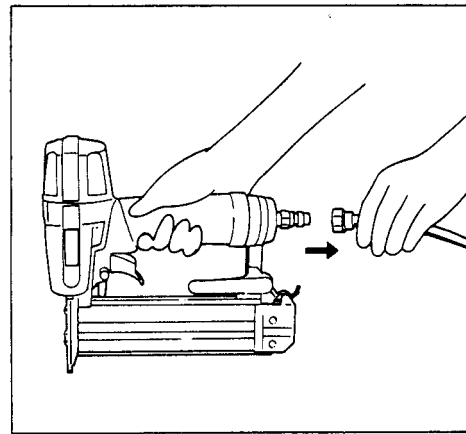

Operation

Release the trigger by turning the lock knob. Place the driver guide against the workpiece and pull the trigger. Nails will be driven into the workpiece. When nails are depleted, the trigger cannot be pulled because a mechanism actuates. Load nails into the magazine, and the trigger can now be pulled.

CAUTION:

- The mechanism cannot actuate when the slide door is open. So always lock the trigger by turning the lock knob to prevent accidental firing when the slide door is open.
- Operating the tool without nails shortens the life of the tool and should be avoided.

Air exhaust

Air exhaust direction can be changed easily by rotating the exhaust cover. Change it when necessary.

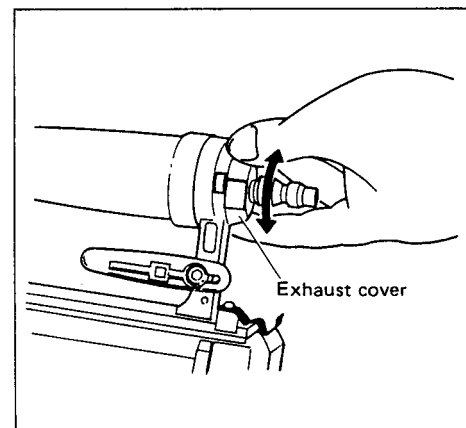

Jammed nailer

When the nailer becomes jammed, proceed as follows:

1. First, lock the trigger and disconnect the hose.
2. Remove the three screws which secure the driver guide. Remove the driver guide.
3. Remove the jammed nail from the ejection slot.

To reassemble the tool, perform the above operations in reverse sequence.

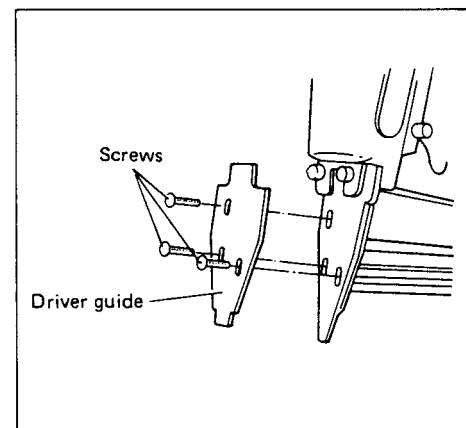

Hook

The hook is convenient for hanging the tool temporarily. This hook can be installed on either side of the tool.

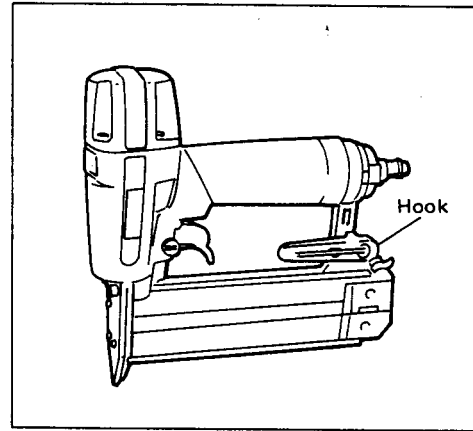

CAUTION:

- Always lock the trigger and disconnect the hose when hanging the tool using the hook.
- Never hang the tool on a waist belt or the like. Dangerous accidental firing may result.

Nails

Handle nail strips and their box carefully. If the nail strips have been handled roughly, they may be out of shape or their connector breaks, causing poor nail feed.

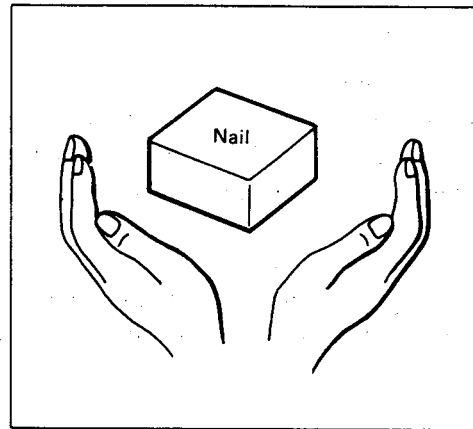

Avoid storing nails in a very humid or hot place or place exposed to direct sunlight.

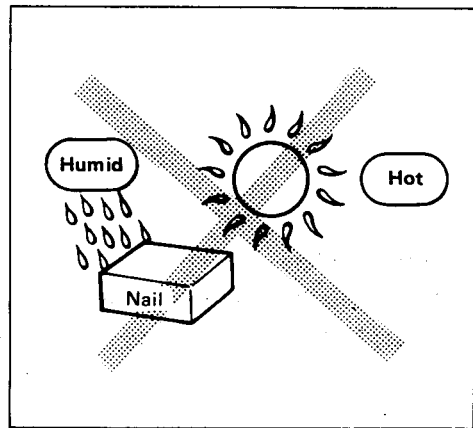

Check regularly to see if there is sufficient pneumatic oil in the oiler of the air set. Failure to maintain sufficient lubrication will cause O-ring to wear quickly.

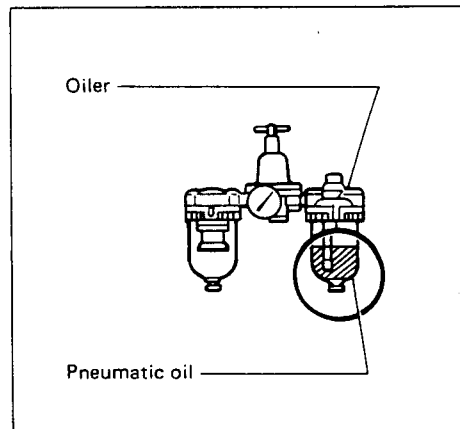

Keep the air hose away from heat (over 60°C, over 140°F), away from chemicals (thinner, strong acids or alkalis). Also, route the hose away from obstacle which it may become dangerously caught on during operation. Hoses must also be directed away from sharp edges and areas which may lead to damage or abrasion to the hose.

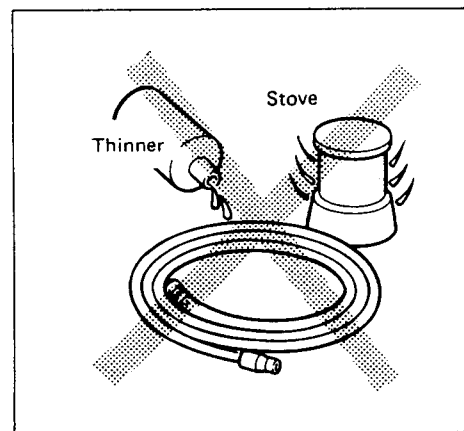

To maintain product SAFETY and RELIABILITY, maintenance and repairs should be performed by Makita Authorized or Factory Service Centers, always using Makita replacement parts.

MAKITA LIMITED ONE YEAR WARRANTY

Warranty Policy

Every Makita tool is thoroughly inspected and tested before leaving the factory. It is warranted to be free of defects from workmanship and materials for the period of ONE YEAR from the date of original purchase. Should any trouble develop during this one-year period, return the COMPLETE tool, freight prepaid, to one of Makita's Factory or Authorized Service Centers. If inspection shows the trouble is caused by defective workmanship or material, Makita will repair (or at our option, replace) without charge.

This Warranty does not apply where:

- repairs have been made or attempted by others;
- repairs are required because of normal wear and tear;
- The tool has been abused, misused or improperly maintained;
- alterations have been made to the tool.

IN NO EVENT SHALL MAKITA BE LIABLE FOR ANY INDIRECT, INCIDENTAL OR CONSEQUENTIAL DAMAGES FROM THE SALE OR USE OF THE PRODUCT. THIS DISCLAIMER APPLIES BOTH DURING AND AFTER THE TERM OF THIS WARRANTY.

MAKITA DISCLAIMS LIABILITY FOR ANY IMPLIED WARRANTIES, INCLUDING IMPLIED WARRANTIES OF "MERCHANTABILITY" AND "FITNESS FOR A SPECIFIC PURPOSE," AFTER THE ONE-YEAR TERM OF THIS WARRANTY.

This Warranty gives you specific legal rights, and you may also have other rights which vary from state to state. Some states do not allow the exclusion or limitation of incidental or consequential damages, so the above limitation or exclusion may not apply to you. Some states do not allow limitation on how long an implied warranty lasts, so the above limitation may not apply to you.

Makita Corporation

3-11-8, Sumiyoshi-cho,
Anjo, Aichi 446 Japan

883858 — 062

PRINTED IN JAPAN
1993 — 10 — N