

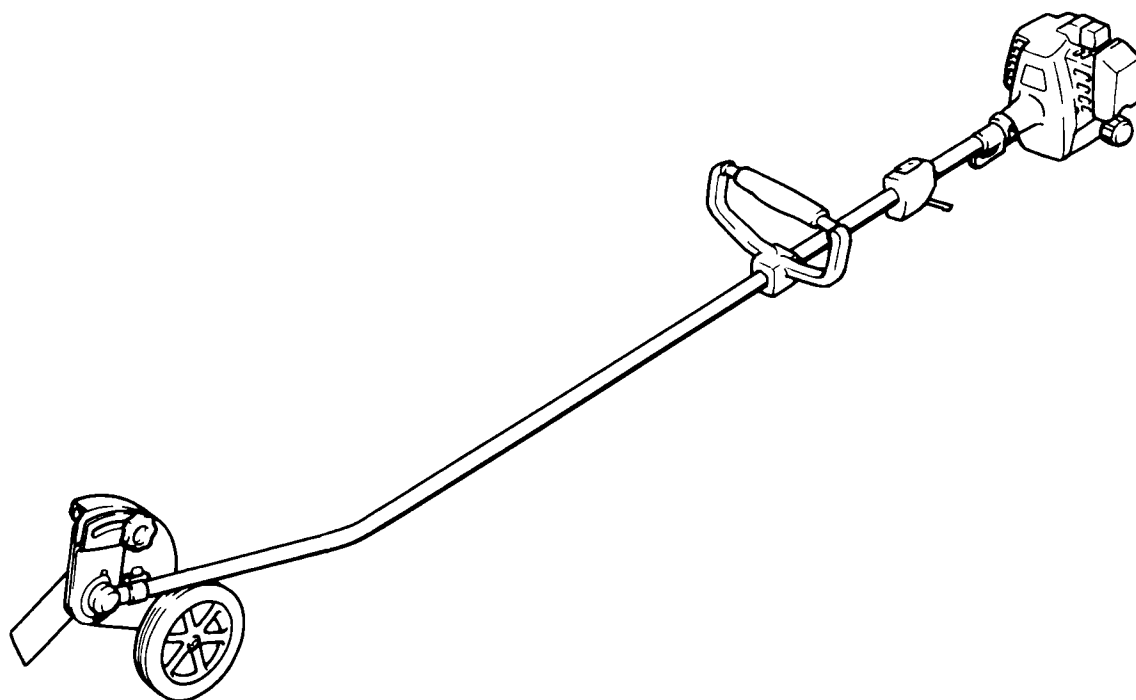

LAWN EDGER

MODEL RBE250

INSTRUCTION MANUAL



Read rules for operation and instructions carefully.

Thank you very much for purchasing the MAKITA LAWN EDGER. We are pleased to recommend to you the MAKITA LAWN EDGER which is the result of a long development programme and many years of knowledge and experience. Please read the booklet that refers to in detail the various points that will demonstrate its outstanding performance. This will assist you to obtain the best possible result from your MAKITA LAWN EDGER.

CAUTION:

- Always stop the engine when a blade jam occurs.
- DO NOT attempt to remove an object causing a blade jam if the engine is running. Physical injury can occur if a blade jam is removed and the blade suddenly starts.
- Keep a firm grip on the edger with both hands, the right hand on the rear handle, the left hand on the front handle. Use a firm grip with thumbs and fingers encircling the handles. A firm grip will help you keep control of the edger.
- NEVER OPERATE the edger with only one hand.
- Before edging, plan your direction of travel so that the until will always be positioned on your right side and so that you walk on hard surface whenever possible.
- Never adjust blade height with engine running.

SAFETY RULES AND PRECAUTIONS

Proper safety precautions must be observed. Like all power equipment this unit must be handled carefully. DO NOT EXPOSE YOURSELF OR OTHERS TO DANGER. Follow these simple rules.

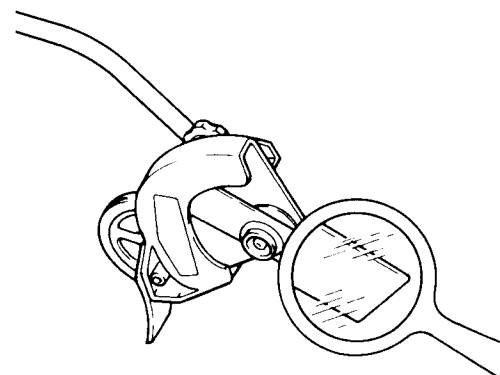
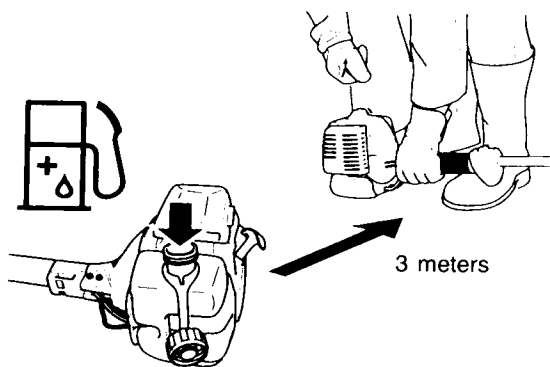
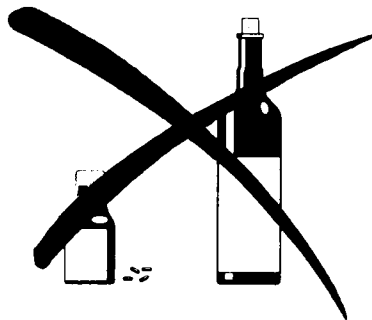

1. For safety and proper operation, read this instruction manual carefully and thoroughly, familiarize yourself with the unit before use. Failure to do so may result in serious injury to yourself or bystanders.
2. Children and young persons aged under 18 years must not be allowed to operate the stick edger. Persons over the age of 16 years may however use the device for the purpose of being trained only whilst under supervision of a qualified trainer.
3. Do not operate the unit when fatigued or under the influence of alcohol or drugs.
4. Dress properly, do not wear loose clothing or jewelry that could become caught in moving parts of the unit. Wear proper protectors such as safety goggles, ear plugs, sturdy gloves, safety footwear, etc.
5. Keep the handles free of oil and fuel.
6. Do not smoke while mixing fuel or filling tank.
7. Do not mix fuel in an enclosed room or near open flames.
8. Always mix and store the fuel in a properly marked container that is approved for such usage.
9. When refueling, be sure to stop the engine and confirm that it is cooled down. Never refuel when the engine is running or hot.
10. Do not start the engine in the place of refueling. Move at least 3 m (10 feet) away from the place of refueling.
11. If fuel is spilled, be sure to wipe it up completely and properly dispose of those materials before starting the engine.
12. Never start or run the engine inside a closed room or building. Fumes from the exhaust contain dangerous carbon monoxide.
13. Inspect the entire unit for loosening, missing and damage of the parts (especially the cutter blade). Never use cracked, deformed or damaged cutter blade.
14. Do not operate the unit without the blade cover (guard) in place.

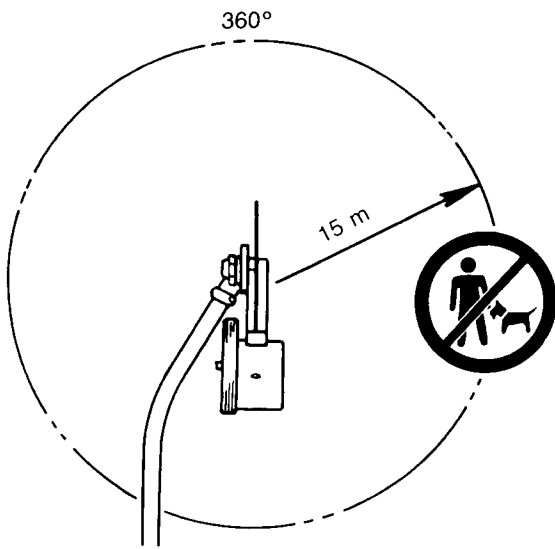

15. In startup or during operation, pay attention to anyone or any objects in working vicinity. Start the engine on a flat, clear surface. Operate the unit by yourself.
16. Inspect the area to be cut and remove all debris that could become entangled in the blade. Also remove any objects that the unit may sling during cutting.
17. Keep hands, feet, clothing, and the like well away from cutting member and moving parts.
18. Do not overreach. Keep proper footing and balance at all times. Do not run the unit standing on a ladder or any other unstable footing. Keep handles dry, clean, and free from oil and fuel.
19. Keep children away. Onlookers should be kept at a safe distance from the work area, at least 50 feet.
20. Do not use the unit on graveled surfaces. Never operate the unit without good visibility or light. Always push slowly over rough ground.
21. Objects struck by the cutting member can cause severe injuries to persons. The lawn should always be carefully examined and cleared of all objects prior to edging.
22. Never direct discharge of material toward bystanders nor allow anyone near the area of operation. Use care in directing discharge to avoid glass enclosures, automobiles, and the like.
23. Use the unit only for edging the grass, lawn or weeds.
24. If the unit strikes a foreign object, stop the engine and disconnect the spark plug lead. Inspect for damage. Repair any damage before restarting and operating the unit.
25. Never attempt to make engine adjustments while the unit is running. Always make engine adjustments with the unit resting on a flat, clear surface.
26. Do not put the hot engine onto dry grass or combustible materials.
27. Stop the engine and disconnect the spark plug lead before replacing the cutter blade, adjusting or maintaining the unit.
28. Periodically clean and inspect the unit for loose parts (screws, bolts, nuts, etc.). Tighten them if necessary.
29. Do not use any attachment with this power head other than those recommended by the manufacture of the engine. Never tamper with the unit. Serious injury to the user or bystanders or damage to the engine could result.
30. Do not attempt to repair the unit. Have repairs made by qualified dealer or repairman, using only identical replacement parts.
31. When not in use, the unit should be stored in dry place after draining all fuel from the fuel tank and carburetor. Do not store in a closed area where fuel vapors can reach an open flame from hot water heaters, furnaces, etc.

DESIGNATION OF PARTS

- (1) Blade Cover
- (2) Blade
- (3) Gear Case
- (4) Debris Deflector
- (5) Drive Shaft
- (6) Loop Handle
- (7) Throttle Lever
- (8) Fuel Tank
- (9) Clutch Case
- (10) Carburetor
- (11) Plug
- (12) Air Cleaner
- (13) Choke Lever
- (14) Starter Knob
- (15) Pump
- (16) Tank Cap
- (17) Recoil Starter
- (18) Exhaust Pipe
- (19) Muffler
- (20) Wheel

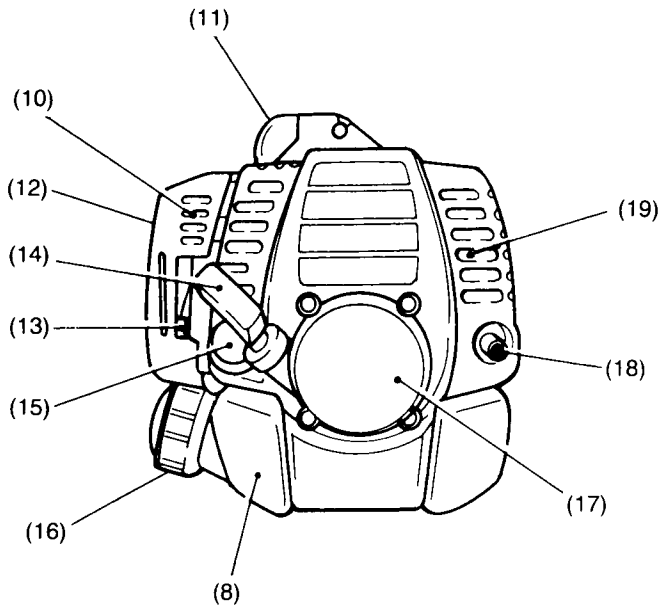
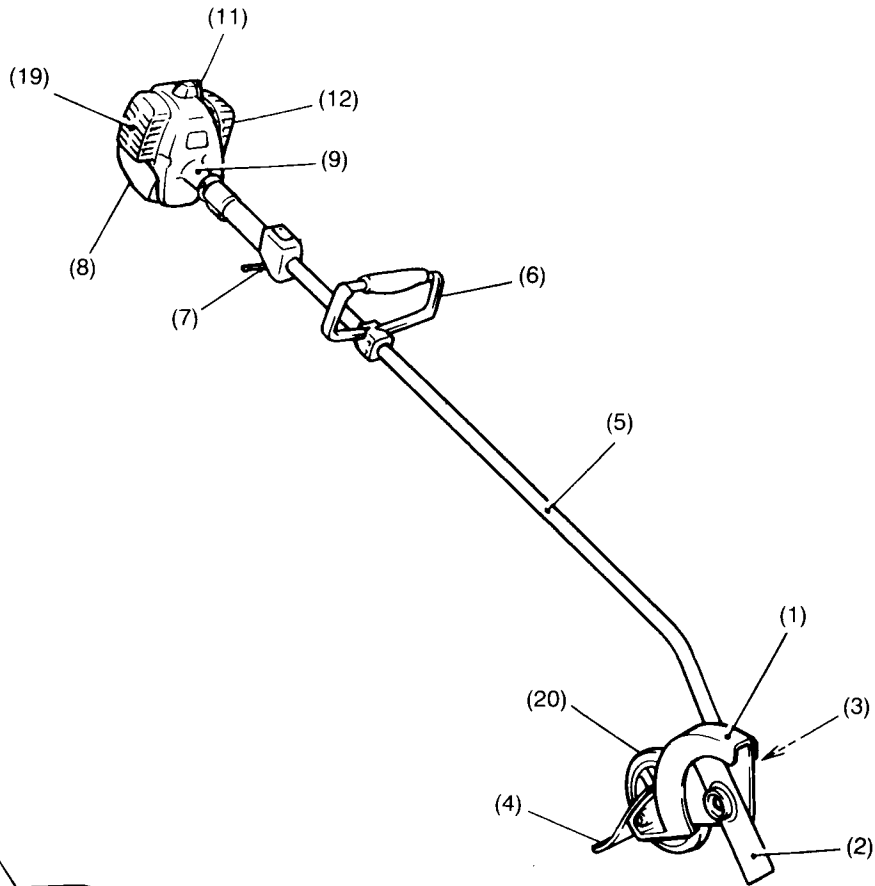

Model	RBE250
Dimensions (L x W x H) (mm)	1,710 x 320 x 295 (67-5/16" x 12-19/32" x 11-19/32")
Weight (kg)	4.9 (10.7 lbs)
Revolution of cutter head (rpm)	6,000
Clutch	Automatic centrifugal type
Engine	EC025G
Displacement (cc)	24.5
Powerrating (kg)	1.3
Carburetor	All position diaphragm type
Starting system	Recoil starter
Ignition system	Solid state ignition
Plug	NGK BM7A or equivalent
Fuel tank (l)	0.5 (0.48 quarts)
Fuel	Mixed gas (Gasoline: Makita Genuine 2 stroke Engine Oil = 50 : 1)

NOTE: Specifications are subject to change without notice.

ASSEMBLY INSTRUCTION

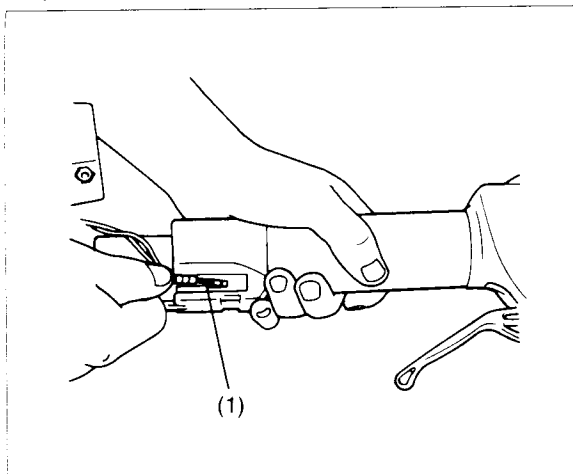

CAUTION:

Before doing any work on the lawn edger, always stop the engine and pull the spark plug connector off the spark plug. Always wear protective gloves!

CAUTION:

Start the lawn edger only after having assembled it completely.

1. Insert the nipple (1) of the throttle wire through the square hole in the grip until it fits into the square hole in the moving part which is inside the grip. It should move when the throttle lever is squeezed.

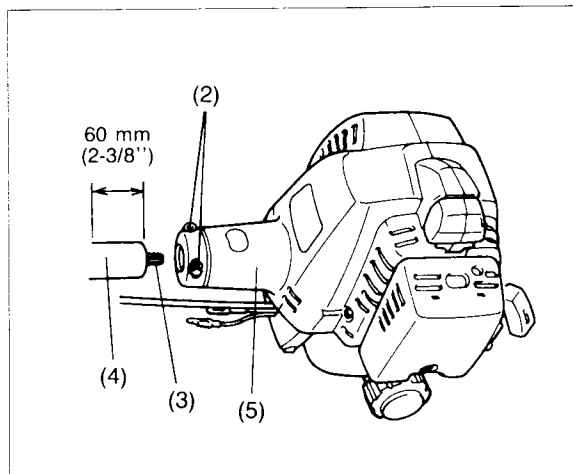

2. Loosen the screws M5 x 18 (2) and insert the drive shaft (4) into the clutch case (5).

NOTE:

Always insert the drive shaft into the clutch case fully (approx. 60 mm; 2-3/8"). If the flexible shaft (3) resists full insertion of the drive shaft, try to insert it again after slightly rotating the drive shaft or the receive washer on the gear case to match the flexible shaft to the hole inside the clutch case.

3. After making sure that the drive shaft is installed fully and properly, tighten the screws M5 x 18 to secure the drive shaft.

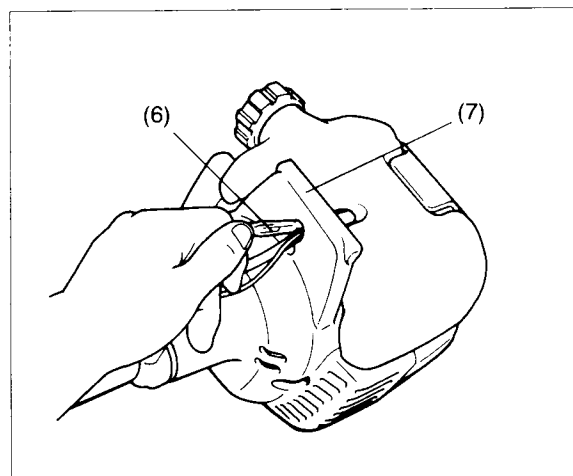

NOTE:

Squeeze the throttle lever to make sure that the throttle wire moves smoothly.

4. Connect the switch cords to the two cords from the engine by inserting one into the other.
5. Insert the bullet connectors (6) through the holes in the cover (7).

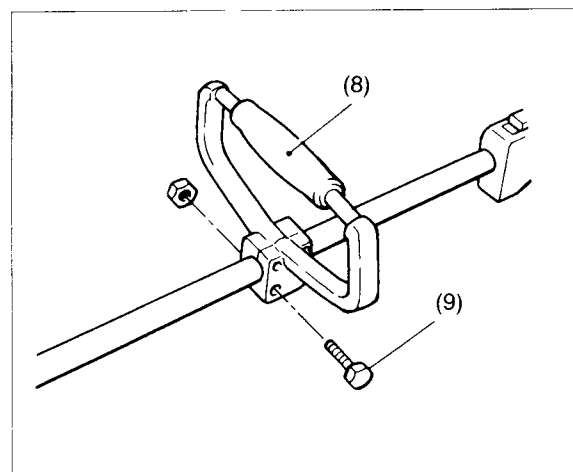

6. After the loop handle (8) is in place, tighten the four bolts (9). Be sure the bolts are tight, but do not over tighten.

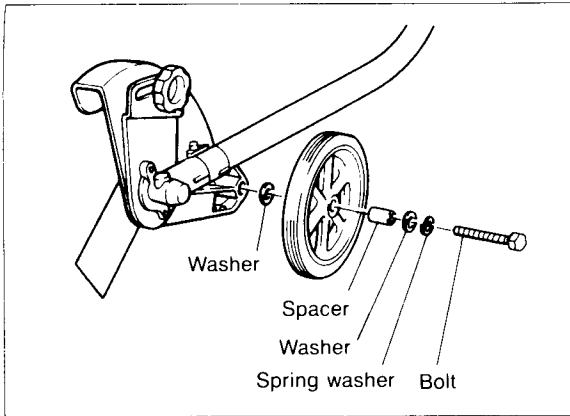

CAUTION:

Stop the engine and disconnect the spark plug lead before installing the wheel and the debris deflector.

7. Mount the wheel as shown in the figure. Tighten the bolt M8 to secure the wheel.

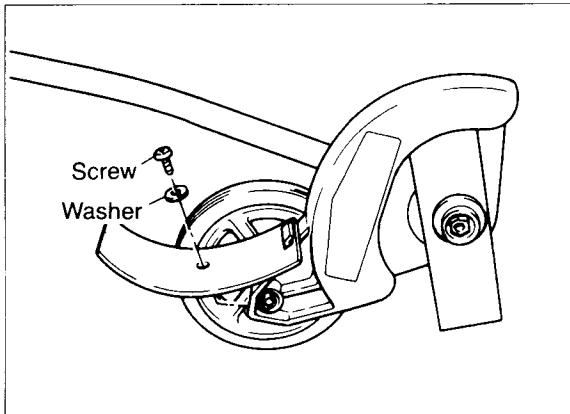

8. Attach the debris deflector onto the hook on the blade cover. Tighten the screw M5 to secure the debris deflector.

FUEL AND MIXTURE

Inspect the fuel tank and fill with clean, fresh fuel of the proper mixture to assure the longer life of the tool. Use the following mixed gas.

- Gasoline : Makita genuine two-stroke engine oil = 50 : 1
- Gasoline : Other maker's two-stroke engine oil = 25 : 1

FOR CALIFORNIA REGULATIONS:
THIS EQUIPMENT IS CERTIFIED TO OPERATE ON GASOLINE + TWO-STROKE OIL

WHEN MIXING GASOLINE WITH TWO-STROKE ENGINE OIL, USE ONLY UNLEADED GASOLINE WHICH CONTAINS NO ETHANOL OR METHANOL (TYPES OF ALCOHOL), THIS WILL HELP TO AVOID POSSIBLE DAMAGE TO ENGINE FUEL LINES AND OTHER ENGINE PARTS.

DO NOT MIX GASOLINE AND OIL DIRECTLY IN THE FUEL TANK.

IMPORTANT:

Failure to follow proper fuel mix instructions may cause damage to the engine.

CAUTION:

1. When preparing fuel mixture, mix only the amount needed for the job you are to do. Do not use fuel mixture that has been stored longer than two months. Fuel mixture stored longer than this will cause hard starting and poor performance. If fuel mix has been stored longer than this time, it should be removed and filled with a fresh mixture.
2. Never fill the fuel tank to the very top.
3. Never add fuel to the tank in a closed unventilated area.
4. Do not add fuel to this unit close to an open fire or sparks.
5. Be sure to wipe off spilled fuel before attempting to start the engine.
6. Do not attempt to refuel a hot engine.

Refuelling

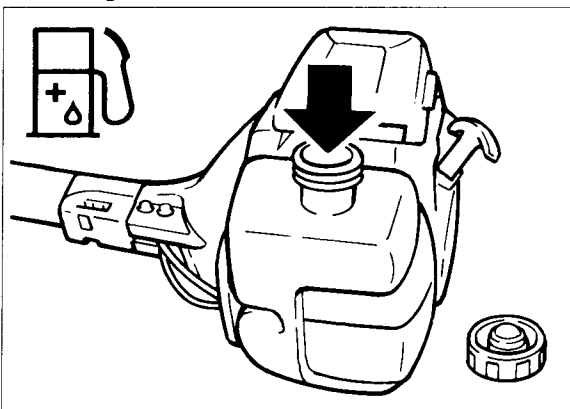

The engine must be switched off.

- Thoroughly clean the area around the plugs (1), to prevent dirt from getting into the fuel tank.
- Unscrew the plug (2) and fill the tank with fuel as the case may be.
- Tightly screw on the plug(2).
- Clean screw plug and tank after refuelling!

CORRECT HANDLING OF MACHINE

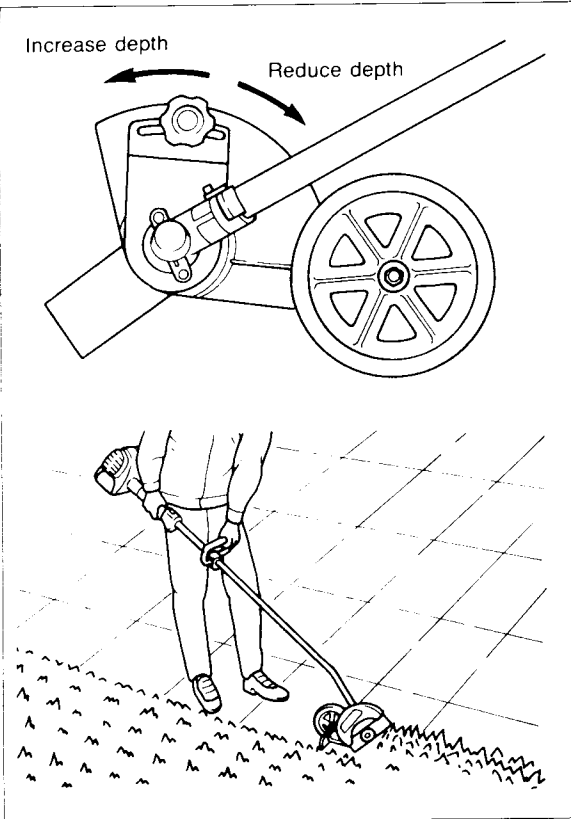

- Before edging, water the area to soften the ground and make edging easier.
- Before edging, check the area and remove all obstacles and objects that could be thrown.
- Plan to edge regularly to make it easier to keep a neat edge and to avoid having to make more than one pass.

NOTE:

Blade depth may have to be adjusted due to differences in height between the hard surface and the top of the grass.

- Adjust the blades' depth of cut to produce a fine cut between sidewalk and grass using a minimum blade depth, usually with about 1/2" of the blade into the ground.

NOTE:

- The blades' depth of cut is adjusted by moving the blade guard.
- Adjust blades' depth of cut by loosening the grip bolt, moving the guard toward the operator to reduce depth or away from the operator to increase depth, and then retightening the bolt.
- When starting to edge, run the engine at full throttle, and lower the blade gently into the ground, being careful not to hit the concrete with the blade.
- Do not force the blade rotate more than the normal rotation.

PUTTING INTO OPERATION

Observe the applicable accident prevention regulations!

STARTING:

Move at least 3 m away from the place of refueling. Place the lawn edger on a clear piece of ground taking care that the cutting tool does not come into contact with the ground or other object.

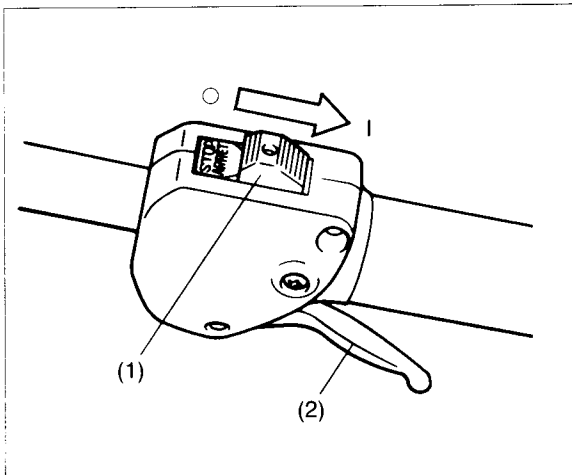

COLD START

1. Push the ON-OFF switch (1) in the direction shown by the arrow.
2. Squeeze the throttle lever (2) fully.

○ : OFF/STOP
I : ON/START

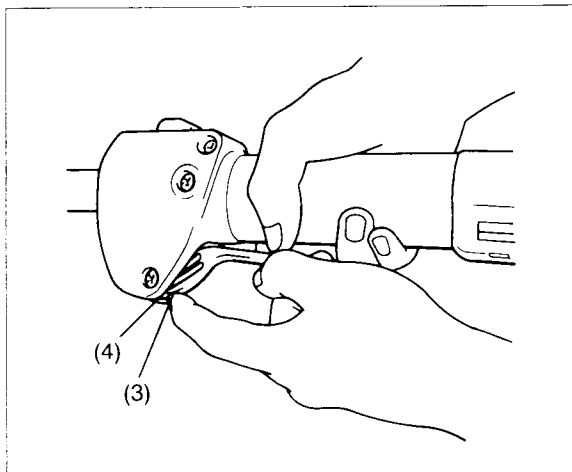

3. Hook the lock fin (3) to the notch (4) in the throttle lever case while releasing the throttle lever.

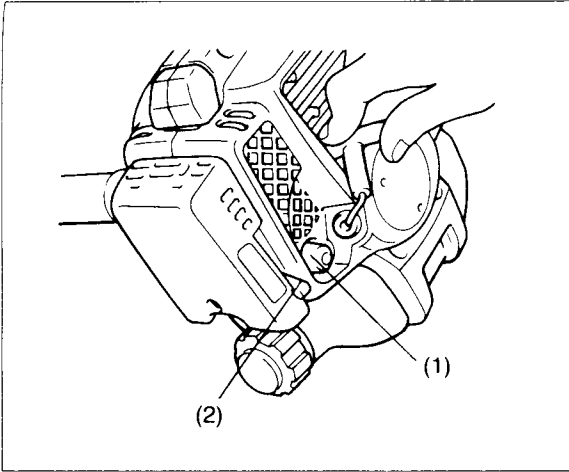

- First place the machine on the ground.
- Give a gentle push on the primer pump (1) repeatedly. (7 - 10 times) until fuel comes into the primer pump.
- Move the choke lever (2) to the top position (|◆|).

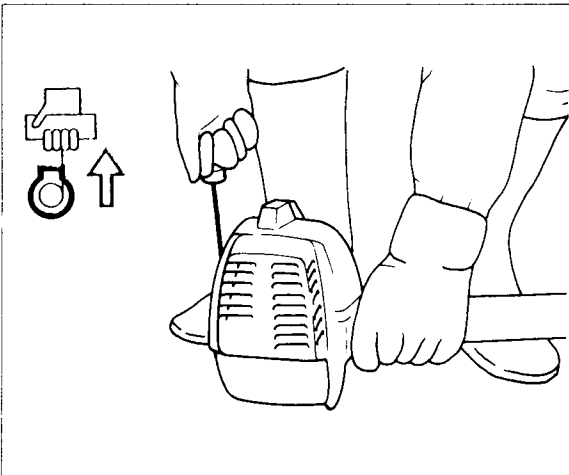

- Firmly hold the holder case by your left hand, as illustrated.
- Slowly withdraw the starter grip until resistance is felt and continue with a smart pull.
- Do not pull out the starter rope to its full extent and do not allow the starter handle to be retracted without control, but ensure that it is retracted slowly.
- Repeat the starting operation until initial ignitions are heard.
- Depress the choke lever (|◆|) and pull the starter rope again until the engine starts.
- As soon as the engine starts, immediately tap and release the throttle, thus releasing the half-throttle lock so that the engine can run in idle.
- Run the engine for approximately one minute at a moderate speed before applying full throttle.

Caution during operation:
 If the throttle lever is opened fully in a no-load operation, the engine rotation is increased to 10,000 rpm or more. Never operate the engine at a higher speed than required and at an approximate speed of 6,000 - 8,000 rpm.

Starting the warm engine

- As described above, except without moving the choke lever (choke lever remains in the down position (|◆|)).

Stopping

- Release the throttle lever fully, and when the engine rpm has lowered, push the ON-OFF switch to "O" position engine will stop.

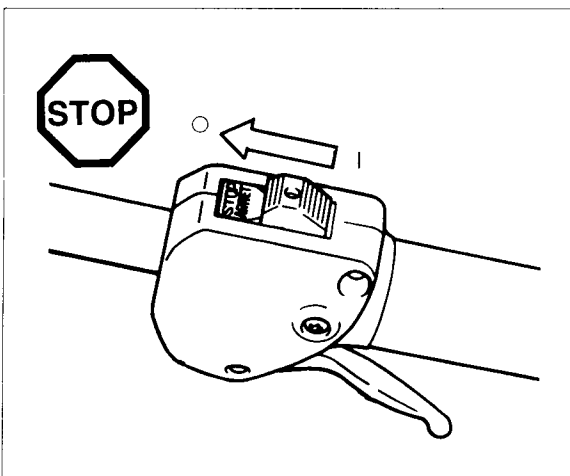

IDLE ADJUSTMENT

The cutter blade should not run when throttle lever is fully released. If necessary, adjust the idle rpm using the idle adjusting screw.

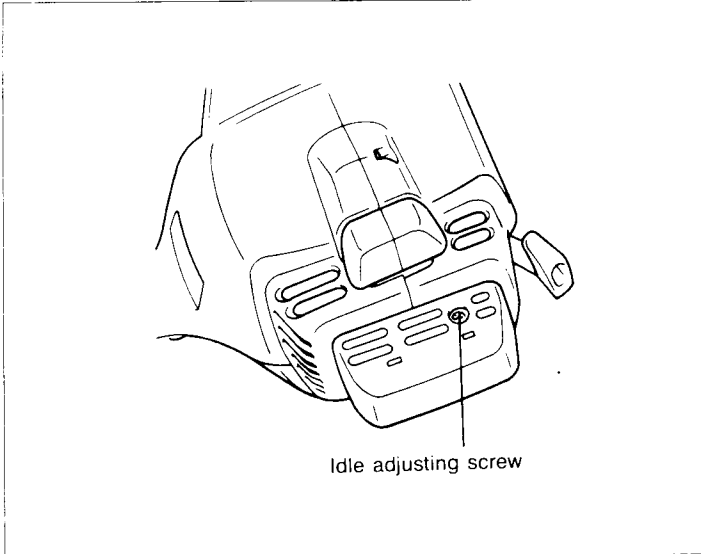

Checking the idling speed

- Idle speed should be set to 2,600 rpm. If necessary correct it by means of the idle screw (the blade must not turn when the engine is on idle). Screwing in of the screw (1) will cause an increase in the engine speed, whereas backing off of the screw will reduce the engine speed.

DAILY CHECKUP AND MAINTENANCE

CAUTION:

Before doing any work on the lawn edger, always switch off the motor and pull the plug cap off the spark plug.

Always wear protective gloves!

To ensure a long service life and to avoid any damage to the equipment, the following servicing operations should be performed at regular intervals.

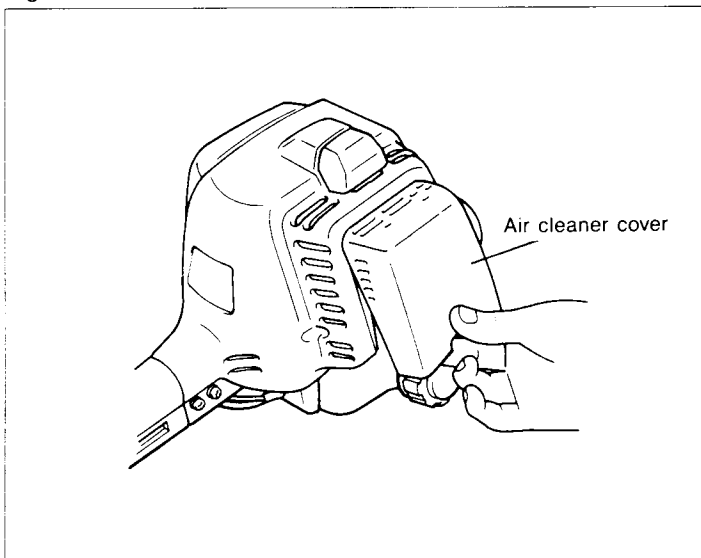

Fig. 1

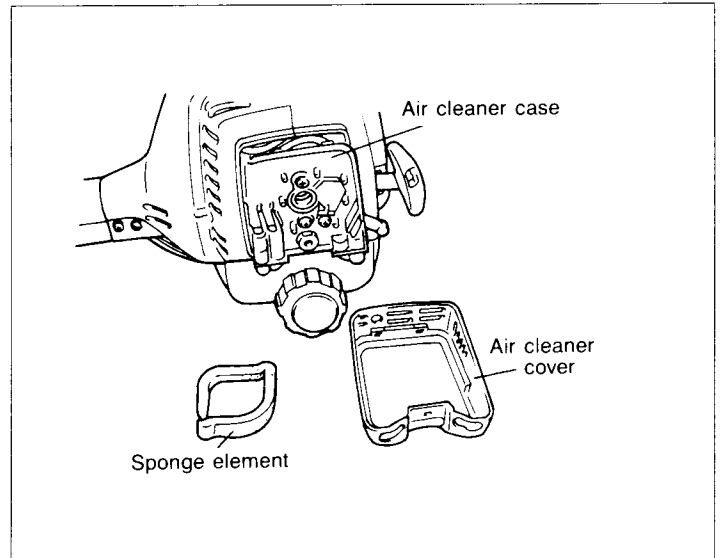

Fig. 2

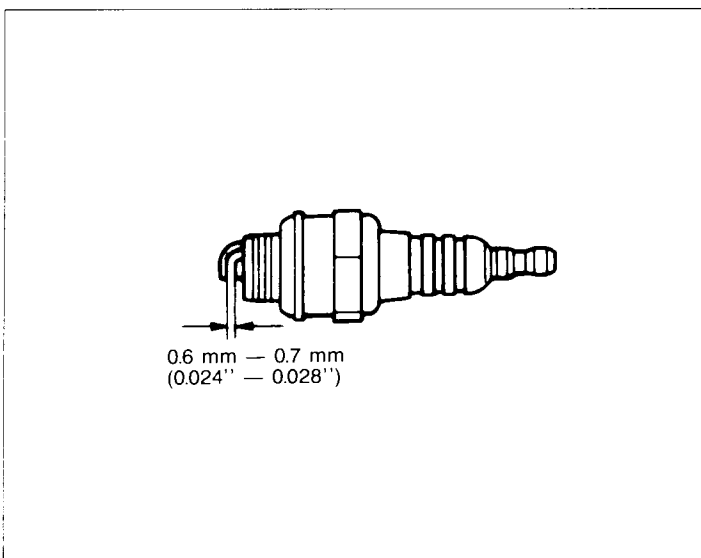

Fig. 3

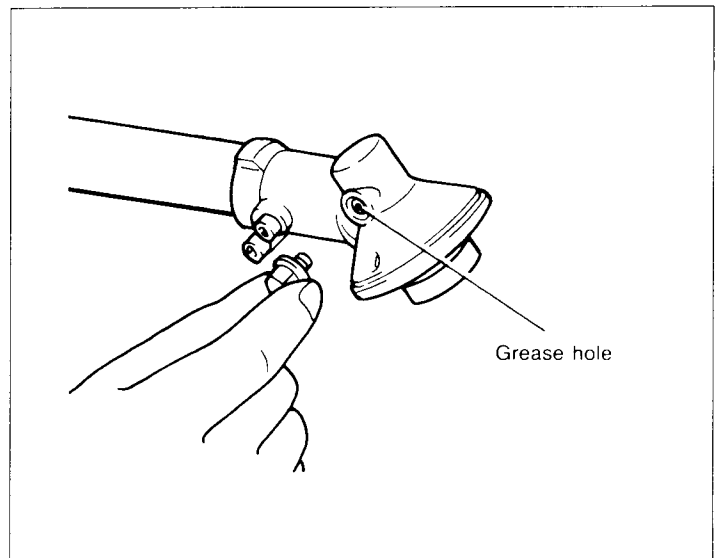
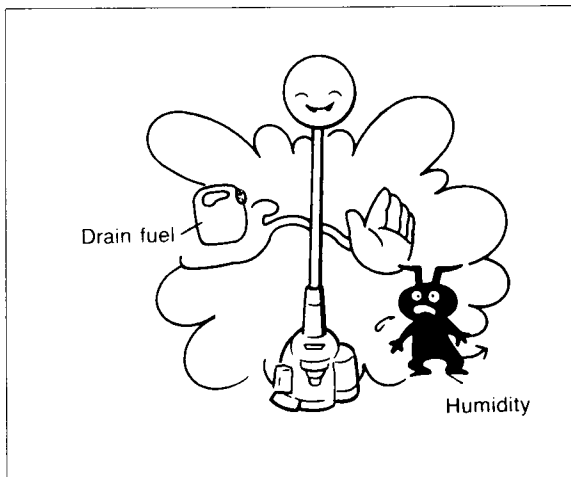

Fig. 4

1. Before operation, pay particular attention to the tightness of Cutter Blade. Check bolts and nuts and retighten if necessary: Every 8 hours (Daily).
2. Check clogging of the cooling air passage and the cylinder fins. Clean them if necessary: Every 8 hours (Daily)
3. Cleaning of air cleaner: Every 8 hours (Daily)
 - 1) Remove the air cleaner cover and clean the sponge element.
If there is excessive dust or dirt adhering to the cleaner, clean it. A clogged air cleaner may make it difficult or impossible to start the engine or increase the engine rotational speed (Fig. 1 and 2)
 - 2) Install the sponge element around the ribs of the air cleaner case.
4. Checkup of spark plug: Every 8 hours (Daily)
The gap between the two electrodes of the spark plug should be 0.6 to 0.7 mm (0.024'' - 0.028''). If the gap is too wide or too narrow, adjust it. If the spark plug is clogged with carbon or fouled, clean it thoroughly or replace it. (Fig. 3)
5. Supply of grease to gear case
Apply grease (Shell alvania No. 3 or equivalent) to the gear case through the grease hole every 30 hours. (Fig. 4)
6. Supply of grease to flexible shaft
Pull the flexible shaft out of the drive shaft and apply grease (Shell alvania No. 2 or equivalent) to the flexible shaft every 10 hours.
7. Cleaning of muffler exhaust port: Every 50 hours (Monthly)
If the exhaust port is clogged with carbon, remove it scrapping and tapping gently with a screwdriver or the like.
8. Check of fuel filter. If clogged, replace with new one.: Every 50 hours
9. Replace fuel lines: Every 200 hours (Yearly)
10. Overhaul engine: Every 200 hours (Yearly)
11. Replace packings and gaskets with new ones: Every time engine is reassembled.

STORAGE



- When keep the machine in storage for a long time, drain fuel from the fuel tank and carburetor, as follows: Drain all fuel from the fuel tank. Dispose of properly and in accordance with all local laws.
- Remove the tank cap and take the filter out of the tank. Depress the primer pump several times until all fuel is expelled out of the primer pump. Then drain all fuel from the fuel tank.
- Remove the spark plug and addition a few drops of oil into the spark plug hole. Then, pull the starter gently, confirm that oil film covers the engine inside and tighten the spark plug.
- Clear dirt or dust from the cutter blade and outside of engine, wipe them with a oil-immersed cloth and keep the machine at a place as dry as possible.

California Emission Control Warranty Statement

YOUR WARRANTY RIGHTS AND OBLIGATIONS

The California Air Resources Board and Makita U.S.A., Inc. are pleased to explain the emission control warranty on your 1995 and later utility and/or lawn and garden equipment engine. In California, new utility and lawn and garden equipment engines must be designed, built and equipped to meet the State's stringent anti-smog standards. Makita U.S.A., Inc. must warrant the emission control system on your utility and/or lawn and garden equipment engine for the periods of time listed below provided there has been no abuse, neglect or improper maintenance of your utility and/or lawn and garden equipment engine.

Your emission control system includes parts such as the carburetor or fuel injection systems, the ignition system and the catalytic converter. Also included are the hoses, and connectors and other emission-related assemblies.

Where a warrantable condition exists, Makita USA, Inc. will repair your utility and/or lawn and garden equipment at no cost to you including diagnosis, parts and labor.

MANUFACTURER'S WARRANTY COVERAGE:

The 1995 and later utility and/or lawn and garden equipment engines are warranted for two years. If any emission-related part on your engine is defective, the part will be repaired or replaced by Makita USA, Inc.

OWNER'S WARRANTY RESPONSIBILITIES:

As the utility and lawn and garden equipment engine owner, you are responsible for the performance of the required maintenance listed in your owner's manual. Makita USA, Inc. recommends that you retain all receipts covering maintenance on your utility and/or lawn and garden equipment engine, but Makita USA, Inc. cannot deny warranty solely for the lack of receipts or for your failure to ensure the performance of all scheduled maintenance.

As the utility and/or lawn and garden equipment engine owner, you should be aware, however, that Makita USA, Inc. may deny you warranty coverage if your utility and/or lawn and garden equipment engine or a part has failed due to abuse, neglect, improper maintenance or unapproved modifications.

You are responsible for presenting your utility and/or lawn and garden equipment engine to a Makita USA, Inc. service center as a problem exists. The warranty repairs should be completed in a reasonable time, not to exceed 30 days.

If you have any questions regarding your warranty rights and responsibilities, you should contact a Makita Factory Service Center Manager nearest you. A list of the Factory Service Center locations and phone numbers is provided below for your convenience.

LIMITED WARRANTY

- California Only -

Makita U.S.A., Inc., a distributor of utility and lawn and garden equipment in the U.S., warrants to the owner of 1995 and later utility and/or lawn and garden equipment engines that the engine (1) has been designed, built, and equipped at the time of manufacture so as to conform with the applicable regulations of the California Air Resources Board, and (2) is free from defects in materials and workmanship which may cause it to fail to conform with those regulations as applicable according to the terms and conditions stated below.

WARRANTY PERIOD

The warranty period begins on the date which the utility and/or lawn and garden equipment engine is delivered to the original retail purchaser and ends two years after that date. During this two year period Makita U.S.A., Inc. warrants to the original retail purchaser and each subsequent purchaser that the engine is free from defect in material and workmanship that can cause the failure of a warranted emission-related part.

WHAT IS COVERED UNDER THIS WARRANTY

Repair and/or replacement of any warranted emission-related part will be performed at no charge provided the work is performed at an authorized warranty station. There will also be no charge for any diagnostic labor performed at an authorized warranty station which leads to the determination that a warranted emission-related part is defective.

Any warranted part which is not scheduled for replacement as required maintenance, or which is scheduled only for regular inspection to the effect of "repair or replace as necessary" shall be warranted for the warranty period. Any warranted part which is scheduled for replacement as required maintenance shall be warranted for the period of time up to the first scheduled replacement of that part. This warranty shall apply only towards the repair, replacement, and/or adjustment of the component parts listed below.

EMISSION-RELATED PARTS COVERED UNDER THIS WARRANTY

1. Fuel Metering Systems
 - (a) Carburetor and its internal parts
 - (b) Air cleaner plate
 - (c) Air cleaner case
 - (d) Air cleaner element
 - (e) Fuel filter
2. Ignition Systems
 - (a) Spark Plug
 - (b) Flywheel Magneto
 - (c) Ignition Coil
3. Other Miscellaneous Items Used in Above Systems
 - (a) Fuel Hoses
 - (b) Sealing Gaskets

If it is determined by an authorized warranty station that other engine components have been damaged due to the failure of a warranted emission-related part during the warranty period, Makita U.S.A., Inc. will repair and/or replace the necessary components.

WHAT IS NOT COVERED UNDER THIS WARRANTY

This warranty does not cover any emission-related part which malfunctions, fails, or is damaged due to alterations and/or modifications such as changing, adding, or removing parts.

When an engine is being serviced under warranty, Makita U.S.A., Inc. and any of its authorized dealers, distributors, or warranty stations shall not be liable for any loss of use of the engine, for any damage to goods, or loss of time or inconvenience.

This limited warranty also does not apply to any emission-related part which malfunctions, fails, or is damaged due to failure to follow the maintenance and operating instructions specified in the 1995 and later Owner's Manual including:

- (a) Improper or inadequate maintenance of any warranted emission-related part.
- (b) Improper installation, adjustment, or repair of the engine or any warranted emission-related part unless performed by a factory authorized warranty station.
- (c) Failure to use recommended fuel as specified in the 1995 and later Owner's Manual.
- (d) Repairs and diagnosis performed outside of an authorized warranty station.
- (e) Use of parts which are not authorized by Makita U.S.A., Inc.

MAINTENANCE SCHEDULE

The engine owner is responsible for having all scheduled inspection and maintenance services performed at the intervals specified in the 1995 and later Owner's Manual and to retain records of these services as having been performed. These records should be transferred to each subsequent owner of the engine. Makita U.S.A., Inc., cannot deny a claim solely because there are no records of scheduled maintenance; however, a warranty claim may be denied if the failure to perform the scheduled maintenance and inspection resulted in the failure of a warranted emission-related part. As a minimum, the engine owner is responsible for the scheduled inspection and maintenance described below which are based on the procedures described in the Owner's Manual.

PROCEDURE

- (a) Check all nuts and bolts and tighten as necessary.
- (b) Check air passages and engine cylinder fins for clogging.
Remove all obstructions as necessary.
- (c) Clean air cleaner.
- (d) Check spark plug. Clean and adjust if necessary.
- (e) Check muffler exhaust port. Clean if necessary.
- (f) Check fuel filter. If clogged, replace with new filter.
- (g) Replace fuel lines.
- (h) Overhaul engine.
- (i) Replace packings and gaskets.

INTERVAL

- Every 8 hours of use or daily.
- Every 8 hours of use or daily.
- Every 8 hours of use or daily.
- Every 8 hours of use or daily.
- Every 50 hours of use or monthly.
- Every 50 hours of use or monthly.
- Every 200 hours of use or annually.
- Every 200 hours of use or annually.
- Every time engine is reassembled.

REPAIR AND REPLACEMENT OF EMISSION-RELATED PARTS

It is recommended that only engine replacement parts which have been authorized and approved by Makit U.S.A., Inc. should be used in the performance of any warranty maintenance or repairs of emission-related parts. These replacement parts will be provided at no charge if the part is still under warranty.

HOW TO FILE A WARRANTY CLAIM AND WHERE TO GET WARRANTY SERVICES

Contact the nearest Makita Factory Service Center Manager to determine the appropriate location where the required warranty services are to be performed. A list of the Factory Service Center locations and phone numbers are provided below for your convenience.

14930 Northam Street
La Mirada, CA 90638-5753
(714) 522-8088

1421N. Clovis Ave., Ste. 112
Fresno, CA 93727
(209) 252-5166

392 S. Arrowhead Ave., #A-1
San Bernardino, CA 92408
(909) 885-1289

333 Littlefield Ave.
S. San Francisco, CA 94080
(415) 875-1002

16735 Saticoy St., Ste. 105
Van Nuys, CA 91406
(818) 782-2440

41850 Christy Street
Fremont, CA 94538-5107
(510) 657-9881

4554 Roseville Rd., Ste E
North Highlands, CA 95660
(916) 331-6211

7674 Clairemont Mesa Blvd.
San Diego, CA 92111
(619) 278-4471

1714 E McFadden Ave., Unit M
Santa Ana, CA 92705
(714) 667-5066



WARNING: The Engine Exhaust from this product contains chemicals known to the State of California to cause cancer, birth defects or other reproductive harm.

Makita Corporation
3-11-8, Sumiyoshi-cho,
Anjo, Aichi 446 Japan