

***lenovo***

# M500 Projector User's Guide



***lenovo***

# M500 Projector User's Guide



---

# Contents

## Safety information . . . . . v

### General safety guidelines. . . . . vii

Service . . . . .	vii
Power cords and power adapters . . . . .	vii
Extension cords and related devices . . . . .	vii
Plugs and outlets . . . . .	vii
Batteries . . . . .	viii
Heat and product ventilation . . . . .	viii
CD and DVD drive safety. . . . .	ix

### Registering your option. . . . . xi

### Chapter 1. Product Description . . . . . 1-1

Packing checklist . . . . .	1-2
Top view of the projector . . . . .	1-3
Rear view of the projector . . . . .	1-5
Bottom view of the projector . . . . .	1-6
Remote control parts . . . . .	1-6
Remote control operating range . . . . .	1-8
Projector and remote control buttons. . . . .	1-9

### Chapter 2. Setup and Operation. . . . . 2-1

Inserting remote control batteries . . . . .	2-1
Connecting input devices . . . . .	2-2
Connecting to a USB device. . . . .	2-2
Starting and shutting down the projector . . . . .	2-3
Setting access passwords (security lock). . . . .	2-4
Adjusting the projected image position . . . . .	2-6
Adjusting zoom, focus and keystone. . . . .	2-7
Adjusting volume . . . . .	2-8
Adjusting with the projector quick menu button . . . . .	2-8

### Chapter 3. On-screen display (OSD) menu settings . . . . . 3-1

OSD menu controls . . . . .	3-1
Navigating the OSD . . . . .	3-1
Setting the OSD language . . . . .	3-3
Quality menu . . . . .	3-3
Quality menu functions available for connected source . . . . .	3-4
Properties menu . . . . .	3-5
Properties menu functions available for connected source . . . . .	3-6
Advance features . . . . .	3-7
User Color . . . . .	3-8
Options menu . . . . .	3-10
Setup menu. . . . .	3-11
Setup menu functions available for connected source . . . . .	3-12

Language menu . . . . .	3-12
Information menu . . . . .	3-13

### Appendix A. Maintenance . . . . . A-1

Replacing the projection lamp. . . . .	A-1
Resetting the lamp . . . . .	A-2
Cleaning the projector . . . . .	A-3
Cleaning the lens . . . . .	A-3
Cleaning the case . . . . .	A-3
Using the Kensington lock . . . . .	A-4

### Appendix B. Troubleshooting . . . . . B-1

Common problems and solutions. . . . .	B-1
Troubleshooting tips . . . . .	B-1
LED error messages . . . . .	B-1
Image problems . . . . .	B-2
Lamp problems. . . . .	B-2
Remote control problems . . . . .	B-3
Audio problems . . . . .	B-3
Servicing the projector . . . . .	B-3

### Appendix C. Specifications . . . . . C-1

Specifications . . . . .	C-1
Projection distance vs. projection size . . . . .	C-2
Timing mode table . . . . .	C-3

### Appendix D. Service and Support. . . . . D-1

Online technical support . . . . .	D-1
Telephone technical support . . . . .	D-1

### Appendix E. Lenovo Statement of Limited Warranty . . . . . E-1

Part 1 - General Terms . . . . .	E-1
Part 2 - Country-unique Terms . . . . .	E-3
Part 3 - Warranty Information . . . . .	E-13
Warranty Period . . . . .	E-13
Types of Warranty Service . . . . .	E-13
Worldwide telephone list . . . . .	E-14
Guarantee supplement for Mexico . . . . .	E-17

### Appendix F. Notices. . . . . F-1

Trademarks . . . . .	F-2
----------------------	-----

### Appendix G. Electronic emission notices . . . . . G-1

Federal Communications Commission (FCC)	
Declaration of Conformity . . . . .	G-1



---

## Safety information

Before installing this product, read the Safety Information.

مج، يجب قراءة دات السلامة

Antes de instalar este produto, leia as Informações de Segurança.

在安装本产品之前，请仔细阅读 **Safety Information** (安全信息)。

Prije instalacije ovog produkta obavezno pročitajte Sigurnosne Upute.

Před instalací tohoto produktu si přečtěte příručku bezpečnostních instrukcí.

Læs sikkerhedsforskrifterne, før du installerer dette produkt.

Ennen kuin asennat tämän tuotteen, lue turvaohjeet kohdasta Safety Information.

Avant d'installer ce produit, lisez les consignes de sécurité.

Vor der Installation dieses Produkts die Sicherheitshinweise lesen.

Πριν εγκαταστήσετε το προϊόν αυτό, διαβάστε τις πληροφορίες ασφάλειας (safety information).

לפני שתתקינו מוצר זה, קראו את הוראות הבטיחות.

A termék telepítése előtt olvassa el a Biztonsági előírásokat!

Prima di installare questo prodotto, leggere le Informazioni sulla Sicurezza.

製品の設置の前に、安全情報をお読みください。

본 제품을 설치하기 전에 안전 정보를 읽으십시오.

Пред да се инсталира овој продукт, прочитајте информацијата за безбедност.

Lees voordat u dit product installeert eerst de veiligheidsvoorschriften.

Les sikkerhetsinformasjonen (Safety Information) før du installerer dette produktet.

Przed zainstalowaniem tego produktu, należy zapoznać się z książką "Informacje dotyczące bezpieczeństwa" (Safety Information).

Antes de instalar este produto, leia as Informações sobre Segurança.

Перед установкой продукта прочтите инструкции по технике безопасности.

Pred inštaláciou tohto produktu si prečítajte bezpečnostné informácie.

Pred namestitvijo tega proizvoda preberite Varnostne informacije.

Antes de instalar este producto lea la información de seguridad.

Läs säkerhetsinformationen innan du installerar den här produkten.

安裝本產品之前，請先閱讀「安全資訊」。



---

## General safety guidelines

Always observe the following precautions to reduce the risk of injury and property damage.

---

### Service

Do not attempt to service a product yourself unless instructed to do so by the Customer Support Center. Use only a service provider who is approved to repair your particular product.

**Note:** Some parts can be upgraded or replaced by the customer. These parts are referred to as Customer Replaceable Units, or CRUs. Lenovo expressly identifies CRUs as such, and provides documentation with instructions when it is appropriate for customers to replace those parts. You must closely follow all instructions when performing such replacements. Always make sure that the power is turned off and that the product is unplugged from any power source before you attempt the replacement. If you have any questions or concerns, contact the Customer Support Center.

---

### Power cords and power adapters

Use only the power cords and power adapters supplied by the product manufacturer.

Never wrap a power cord around the power adapter or other object. Doing so can stress the cord in ways that can cause the cord to fray, crack or crimp. This can present a safety hazard.

Always route power cords so that they will not be walked on, tripped over, or pinched by objects.

Protect the cord and power adapters from liquids. For instance, do not leave your cord or power adapter near sinks, tubs, toilets, or on floors that are cleaned with liquid cleansers. Liquids can cause a short circuit, particularly if the cord or power adapter has been stressed by misuse. Liquids can also cause gradual corrosion of the power cord terminals and/or the connector terminals on the adapter which can eventually result in overheating.

Always connect power cords and signal cables in the correct order and ensure that all power cord connectors are securely and completely plugged into receptacles.

Do not use any power adapter that shows corrosion at the ac input pins and/or shows signs of overheating (such as deformed plastic) at the ac input or anywhere on the power adapter.

Do not use any power cords where the electrical contacts on either end show signs of corrosion or overheating or where the power cord appears to have been damaged in any way.

---

### Extension cords and related devices

Ensure that extension cords, surge protectors, uninterruptible power supplies, and power strips that you use are rated to handle the electrical requirements of the product. Never overload these devices. If power strips are used, the load should not exceed the power strip input rating. Consult an electrician for more information if you have questions about power loads, power requirements, and input ratings.

---

### Plugs and outlets

If a receptacle (power outlet) that you intend to use with your computer equipment appears to be damaged or corroded, do not use the outlet until it is replaced by a qualified electrician.

Do not bend or modify the plug. If the plug is damaged, contact the manufacturer to obtain a replacement.

Some products are equipped with a three-pronged plug. This plug fits only into a grounded electrical outlet. This is a safety feature. Do not defeat this safety feature by trying to insert it into a non-grounded outlet. If you cannot insert the plug into the outlet, contact an electrician for an approved outlet adapter or to replace the outlet with one that enables this safety feature. Never overload an electrical outlet. The overall system load should not exceed 80 percent of the branch circuit rating. Consult an electrician for more information if you have questions about power loads and branch circuit ratings.

Be sure that the power outlet you are using is properly wired, easily accessible, and located close to the equipment. Do not fully extend power cords in a way that will stress the cords.

Connect and disconnect the equipment from the electrical outlet carefully

---

## Batteries

All personal computers manufactured by Lenovo contain a non-rechargeable coin cell battery to provide power to the system clock. In addition many mobile products such as notebook PCs utilize a rechargeable battery pack to provide system power when in portable mode. Batteries supplied by Lenovo for use with your product have been tested for compatibility and should only be replaced with Lenovo approved parts.

Never attempt to open or service any battery. Do not crush, puncture, or incinerate batteries or short circuit the metal contacts. Do not expose the battery to water or other liquids. Only recharge the battery pack strictly according to instructions included in the product documentation.

Battery abuse or mishandling can cause the battery to overheat, which can cause gasses or flame to “vent” from the battery pack or coin cell. If your battery is damaged, or if you notice any discharge from your battery or the buildup of foreign materials on the battery leads, stop using the battery and obtain a replacement from the battery manufacturer.

Batteries can degrade when they are left unused for long periods of time. For some rechargeable batteries (particularly Lithium Ion batteries), leaving a battery unused in a discharged state could increase the risk of a battery short circuit, which could shorten the life of the battery and can also pose a safety hazard. Do not let rechargeable Lithium-Ion batteries completely discharge or store these batteries in a discharged state.

---

## Heat and product ventilation

Computers generate heat when turned on and when batteries are charging. Notebook PCs can generate a significant amount of heat due to their compact size. Always follow these basic precautions:

- Do not leave the base of your computer in contact with your lap or any part of your body for an extended period when the computer is functioning or when the battery is charging. Your computer produces some heat during normal operation. Extended contact with the body could cause discomfort or, potentially, a skin burn.
- Do not operate your computer or charge the battery near flammable materials or in explosive environments.
- Ventilation slots, fans and/or heat sinks are provided with the product for safety, comfort, and reliable operation. These features might inadvertently become blocked by placing the product on a bed, sofa, carpet, or other flexible surface. Never block, cover or disable these features.

---

## **CD and DVD drive safety**

CD and DVD drives spin discs at a high speed. If a CD or DVD is cracked or otherwise physically damaged, it is possible for the disc to break apart or even shatter when the CD drive is in use. To protect against possible injury due to this situation, and to reduce the risk of damage to your machine, do the following:

- Always store CD/DVD discs in their original packaging
- Always store CD/DVD discs out of direct sunlight and away from direct heat sources
- Remove CD/DVD discs from the computer when not in use
- Do not bend or flex CD/DVD discs, or force them into the computer or their packaging
- Check CD/DVD discs for cracks before each use. Do not use cracked or damaged discs



---

## Registering your option

Thank you for purchasing this Lenovo™ product. Please take a few moments to register your product and provide us with information that will help Lenovo to better serve you in the future. Your feedback is valuable to us in developing products and services that are important to you, as well as in developing better ways to communicate with you. Register your option on the following Web site:

<http://www.lenovo.com/register>

Lenovo will send you information and updates on your registered product unless you indicate on the Web site questionnaire that you do not want to receive further information.



---

## Chapter 1. Product Description

The M500 projector can be used for both business presentations and home entertainment and is easy to connect, use, and maintain. Some main features of this projector are:

- Extremely powerful, lightweight, and portable at 1.1 kg (2.5 lbs).
- Sharp and clear images with a high contrast ratio of 2000:1.
- Bright, high quality images with 1700 lumens and XGA native resolution.
- Beautiful reproduction of high-quality images from PC and AV sources.
- "Off And Go" feature allows the user to unplug the projector after 10 seconds of cool-down.
- Digital technology corrects vertical keystone distortion of the projector pictures.

## Packing checklist

Carefully unpack the projector and check that the following items are included:

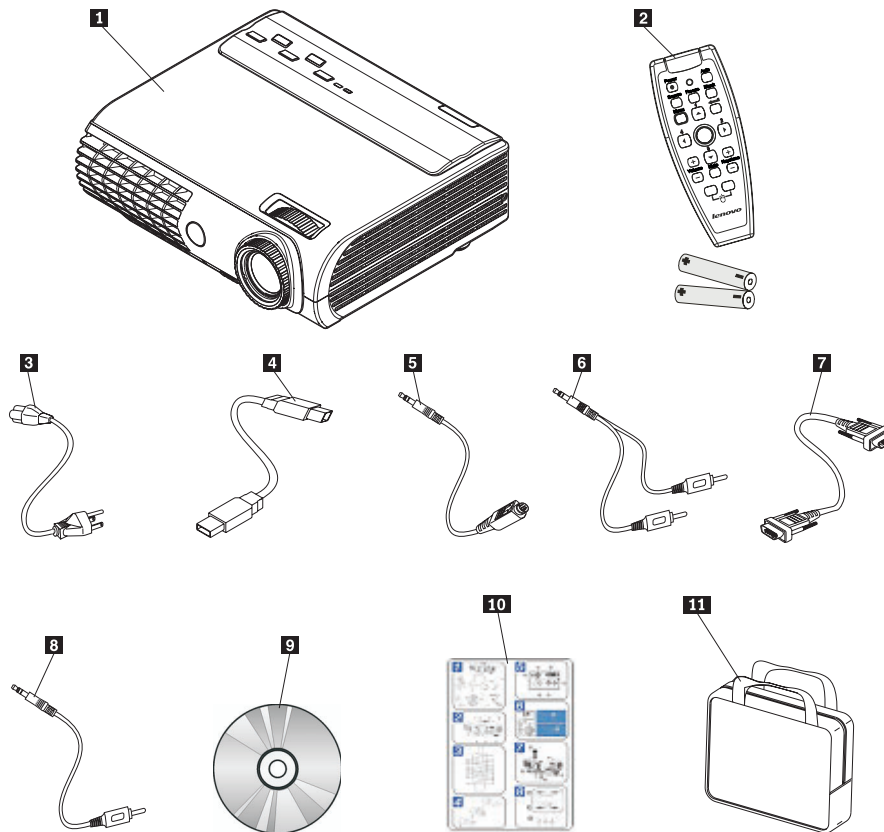

<b>1</b>	Lenovo M500 Projector
<b>2</b>	Remote control and batteries
<b>3</b>	Power cord
<b>4</b>	USB cable
<b>5</b>	S-video cable
<b>6</b>	Audio cable (Mini Jack - RCA)
<b>7</b>	Computer cable
<b>8</b>	Video cable (Mini Jack - RCA)
<b>9</b>	User's guide (and installation) CD
<b>10</b>	Multi-lingual quick start guide
<b>11</b>	Carrying case

Contact your dealer immediately if any items are missing, appear damaged, or if the unit does not work.

**Attention:** Avoid using the projector in dusty environments.



## Top view of the projector

This section provides information on the controls on the top of the projector.

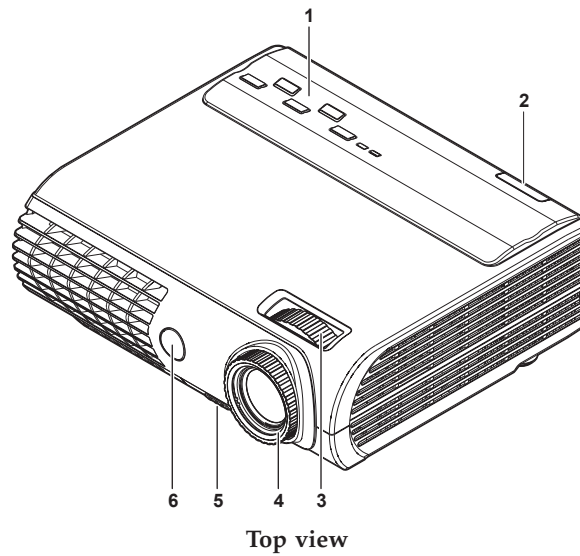

<b>1</b> User controls	See top view detail
<b>2</b> Rear IR receiver	Receives IR signal from remote control
<b>3</b> Lens zoom	Enlarges projected image
<b>4</b> Focus	Clarifies projected image
<b>5</b> Height-adjuster button	Push to release height adjuster
<b>6</b> Front IR receiver	Receives IR signal from remote control

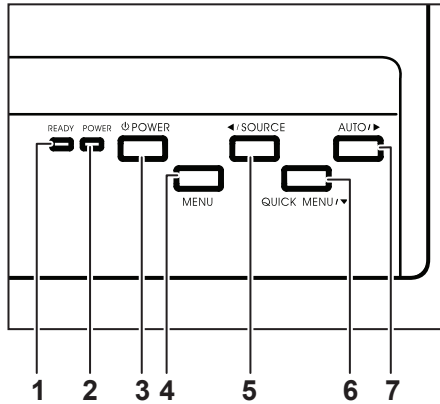

On-Screen Display (OSD) buttons and LEDs

<b>1</b> Ready LED	Orange - Lamp ready, you can safely turn off projector or unplug the projector Flashing - do not press power button
<b>2</b> Power LED	Green - Unit is powered on and working Off - Unit is powered off Flashing - operational error code. For more information, refer to "LED error messages" on page B-1.
<b>3</b> Power button	Turns the projector on or off
<b>4</b> Menu	Opens and exits the OSD
<b>5</b> Source/Left cursor	Detects the input device Navigates and changes settings in the OSD
<b>6</b> Quick menu/Down cursor	Opens a quick menu for brightness, contrast, volume and keystone adjustment Navigates and changes settings in the OSD
<b>7</b> Auto/Right cursor	Optimizes image size, position and resolution Navigates and changes settings in the OSD

## Rear view of the projector

This section provides information on the items on the back of the projector.

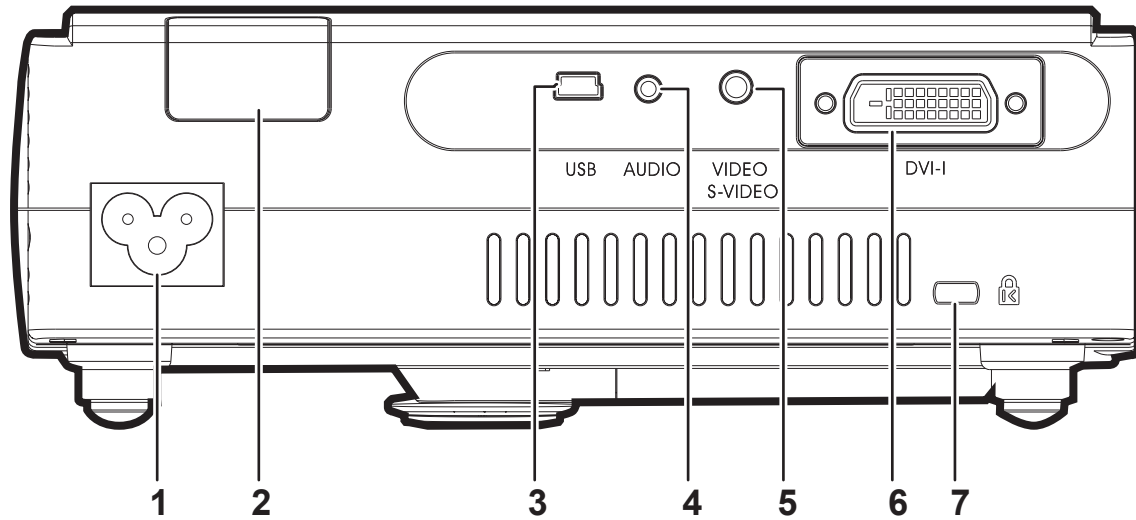

Rear view

<b>1</b> Power	Connects the supplied power cord
<b>2</b> Rear IR receiver	Receiver for IR signal from remote control
<b>3</b> USB	Connects the USB cable from a computer
<b>4</b> Audio-in	Connects the audio cable from the input device
<b>5</b> Video/S-Video	Connects the composite or S-video cable from a video device
<b>6</b> DVI-I	Connects the computer cable from a computer
<b>7</b> Security lock	Secures to permanent object with a Kensington lock system

## Bottom view of the projector

This section provides information on the tilt adjustment foot and projector lamp cover on the bottom of the projector.

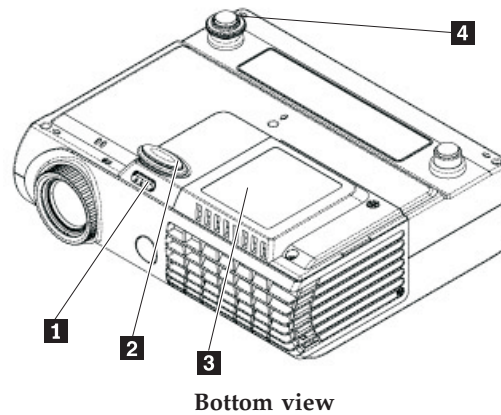

<b>1</b> Height-adjuster button	Push to release height adjuster
<b>2</b> Height adjuster	Adjusts level of projector
<b>3</b> Projection lamp cover	Remove when changing lamp
<b>4</b> Tilt adjustment foot	Turn to adjust the image

---

## Remote control parts

Avoid using the projector with bright fluorescent lighting turned on. Certain high-frequency fluorescent lights can disrupt remote control operation.

Ensure that nothing obstructs the path between the remote control and the projector. If the path between remote control and the projector is obstructed, you can bounce the signal off certain reflective surfaces such as projector screens.

The buttons and keys on the projector have the same functions as the corresponding buttons on the remote control. This user's manual describes the functions based on the remote control.



**Attention:** To reduce the risk of injury to the eyes, do not look directly into the remote control laser light and do not point the laser light into anyone's eyes. The remote control is equipped with a Class II laser that emits radiation.

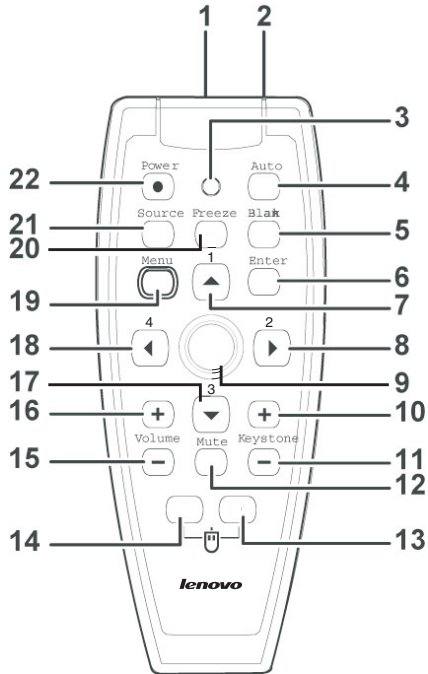

<b>1</b> Laser	Use as on-screen pointer. Do not point in eyes.
<b>2</b> IR transmitter	Transmits signals to projector.
<b>3</b> Status LED	Lights when the remote control is used.
<b>4</b> Auto	Auto adjustment for phase, tracking, size, position.
<b>5</b> Blank	Makes the screen blank.
<b>6</b> Enter	Changes settings in the OSD.
<b>7</b> Up cursor	Navigates and changes settings in the OSD. Page Up when connected through USB to a PC.
<b>8</b> Right cursor	Navigates and changes settings in the OSD. Page Down when connected through USB to a PC.
<b>9</b> Cursor pad	Moves the on-screen cursor when connected through USB to a PC.
<b>10</b> Keystone top	Corrects image-trapezoid (wider top) effect.
<b>11</b> Keystone button	Corrects image-trapezoid (wider bottom) effect.
<b>12</b> Mute	Mutes the built-in speaker.
<b>13</b> Right mouse	Functions as right mouse button when connected through USB to a PC.
<b>14</b> Left mouse	Functions as left mouse button when connected through USB to a PC.
<b>15</b> Volume down	Adjusts volume.
<b>16</b> Volume up	Adjusts volume.
<b>17</b> Down cursor	Navigates and changes settings in the OSD. Page Down when connected through USB to a PC.
<b>18</b> Left cursor	Navigates and changes settings in the OSD. Page Up when connected through USB to a PC.
<b>19</b> Menu	Opens the OSD.
<b>20</b> Freeze	Freeze/unfreezes the on-screen picture.
<b>21</b> Source	Detects the input device.
<b>22</b> Power	Turns the projector on or off.

**Note:** The remote control can only interface with a computer when the projector is connected to the computer through a USB cable connection. The computer cable connects a computer to the projector for display purposes only.

---

## **Remote control operating range**

The remote control uses infrared transmission to control the projector. It is not necessary to point the remote directly at the projector. Provided you are not holding the remote perpendicular to the sides or the rear of the projector, the remote will function well within a radius of about 10 meters (33 feet) and 30 degrees above or below the projector level. If the projector does not respond to the remote control, move a little closer.

## Projector and remote control buttons

The projector can be operated using the remote control or the buttons on the top of the projector. All operations can be carried out with the remote control; however the buttons on the projector are limited in use. The following illustration shows the corresponding buttons on the remote control and on the projector. Some buttons on the projector have multiple functions.

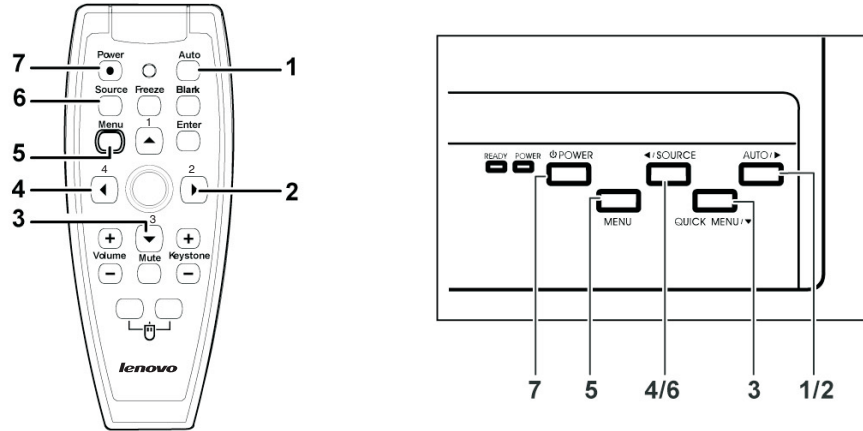

<b>1</b> Auto	Auto adjustment for phase, tracking, size, position.
<b>2</b> Right button	Navigates and changes settings in the OSD. Page Down when connected through USB to a PC.
<b>3</b> Down button	Navigates and changes settings in the OSD. Page Down when connected through USB to a PC.
<b>4</b> Left button	Navigates and changes settings in the OSD. Page Up when connected through USB to a PC.
<b>5</b> Menu	Opens the OSD.
<b>6</b> Source	Detects the input device.
<b>7</b> Power	Turns the projector on or off.





---

## Chapter 2. Setup and Operation

This chapter provides information on positioning the projector, connecting a computer source, using the projector with Microsoft Windows, and displaying and adjusting a computer source image.

**Attention:** Only use AAA alkaline batteries. Dispose of used batteries according to local ordinance regulations. Remove the batteries when not using the projector for prolonged periods.

---

### Inserting remote control batteries

Remove the battery compartment cover by sliding the cover in the direction of the arrow.

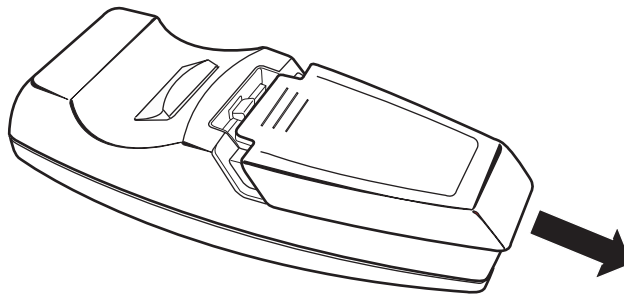

Insert the supplied batteries, taking note of the polarity (+/-) as shown here.

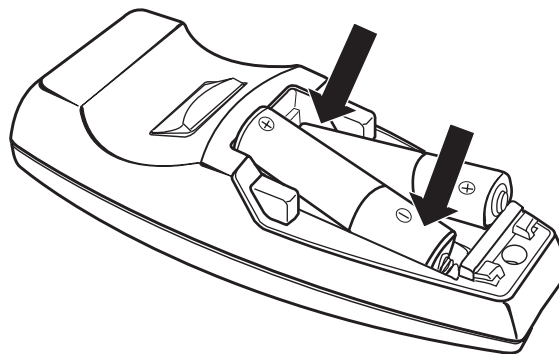

Replace the cover.

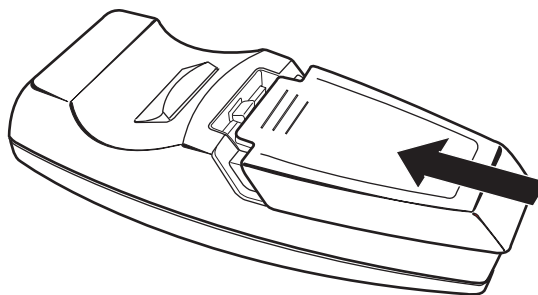

## Connecting input devices

**Attention:** Be sure to disconnect all power to the projector and connecting devices before making connections.

A PC or notebook computer as well as video devices can be connected to the projector at the same time. Video devices include DVD, VCD, and VHS players, as well as movie camcorders and digital still cameras. Check the user manual of the connecting device to confirm it has the appropriate output connector.

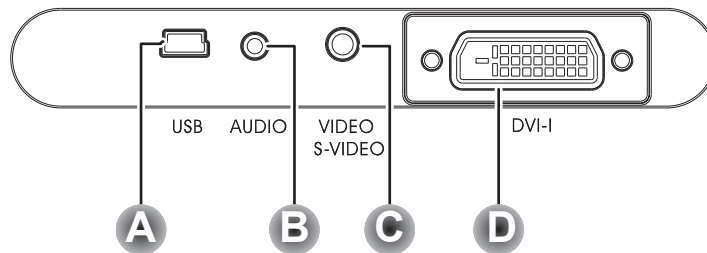

Connecting devices	Description
<b>A</b> USB	Connect the supplied USB cable from a computer.
<b>B</b> Audio-in	Connect the supplied audio cable (mini jack-to-RCA x 2) from a video device. Connect an audio cable (not supplied) from the computer's audio-out connector.
<b>C</b> Video/S-video	Connect the supplied composite video cable from a video device. Connect the supplied S-video cable from a video device
<b>D</b> DVI-I	Connect the supplied computer cable from a computer. Connect a component video cable (not supplied) from a video device.

## Connecting to a USB device

To control your computer mouse using the projector remote control, connect the projector to the computer with a USB cable as shown below.

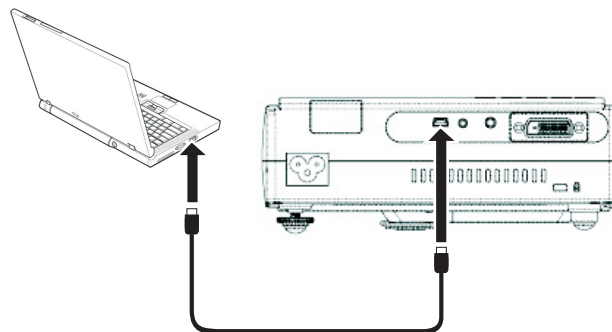

**Note:** USB mouse function is only supported with Windows 2000 and Windows XP.

---

## Starting and shutting down the projector

1. Connect the power cord to the projector. Connect the other end to a wall outlet. This turns on the POWER and READY LEDs on the projector.

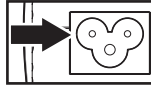

2. Turn on the connected devices.
3. Ensure that the Ready LED is on a steady (not flashing) orange and then press the Power button to turn on the projector. The projector splash screen displays and connected devices are detected. If the connected device is a PC, press the appropriate keys on the computer keyboard to switch the display output to the projector. (Check the user manual of the PC to determine the appropriate Fn key combination to change display output). See "Navigating the OSD on "Navigating the OSD" on page 3-1 if Security Lock is enabled.
4. If more than one input device is connected, press the Source button repeatedly to switch among devices. DVI and component video are supported through the DVI-I connector.



5. To turn off the projector, press the Power button. The projector prepares for shutdown and a "Wait a moment please..." message appears.

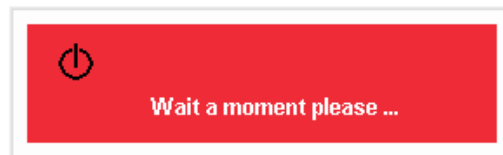

6. When the "Power Off?/Press Power again" message appears, press the Power button. The projector turns off.

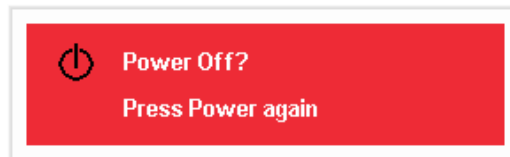

**Note:** This projector has a fast shutdown cycle to let you unplug the projector. However, to allow proper cooling of the bulb, the projector will not turn on again for 60 seconds.

**Attention:** Do not unplug the power cord until the Ready LED stops flashing, indicating the projector has cooled down.

## Setting access passwords (security lock)

You can use the cursor (arrow) buttons on the remote to set a password and prevent unauthorized use of the projector. When enabled, the password must be entered after you power on the projector. (See “Navigating the OSD” on page 3-1 and “Setting the OSD language” on page 3-3 for help on using OSD menus.)

**Attention:** Keep the password in a safe place. Without the password, you will not be able to use the projector. If you lose the password, contact Lenovo support for information on clearing the password.

1. Press Menu to open the OSD menu.
2. Press the left or right cursor button to move to the Properties menu.
3. Press the up or down cursor button to select Advance Feature and press Enter or the right cursor button.

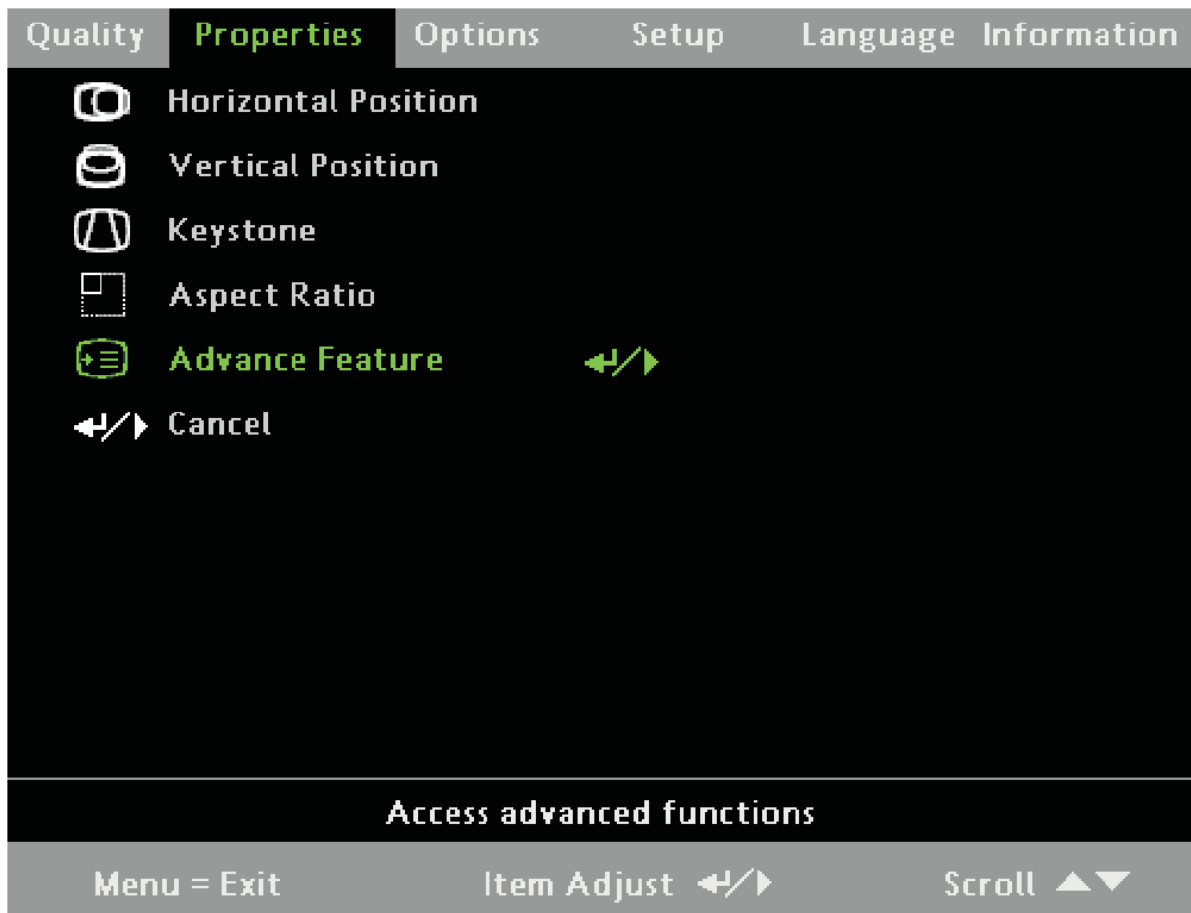

4. Press the up and down cursor button to select Security Lock.

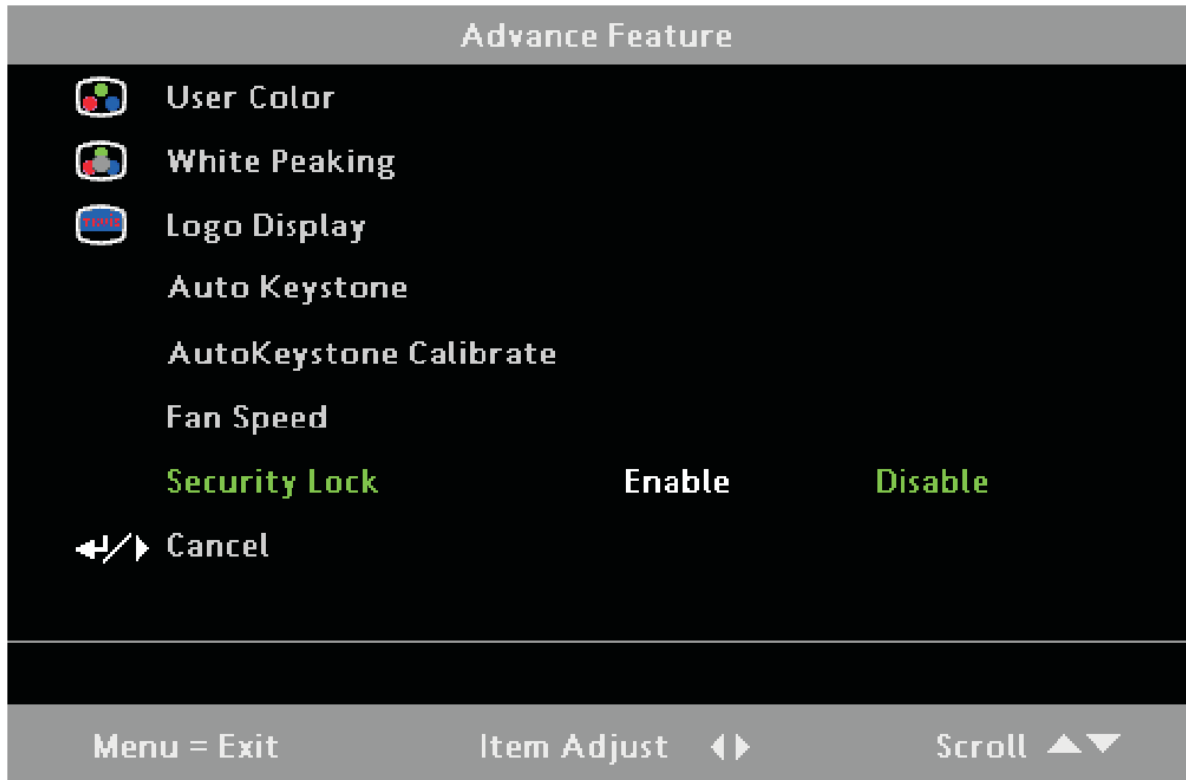

5. Press the left or right cursor button to select Enable (green text is selected). A password dialog box appears.

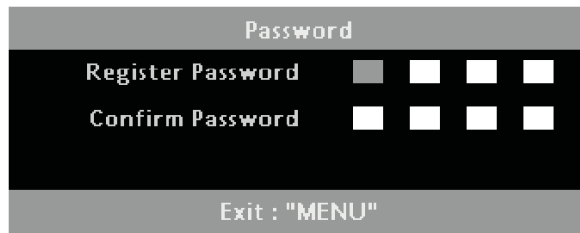

6. You can use the cursor buttons numbered 1, 2, 3, and 4 on the remote to enter the password. You can use any combination including the same number multiple times, but the password must be four characters. After entering the password a second time to confirm it, OK displays.

7. Every time you start the projector a password dialog box appears. Enter the password set in step 6. Press Menu to cancel if you enter the wrong password.

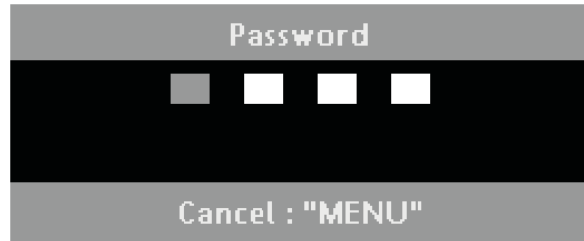

---

## Adjusting the projected image position

Take note of the following when setting up the projector:

- The projector table or stand should be level and sturdy.
- Position the projector so that it is perpendicular to the screen.
- Be sure cables are not in the way or can cause the projector to be knocked over.

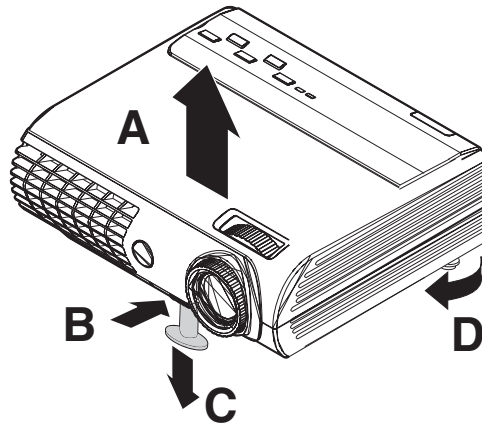

1. To raise the projected image, lift the projector **A** and press the height-adjuster button **B**. The height adjuster drops down **C**.
2. To lower the level of the projector, press the height-adjuster button and push down on the top of the projector.
3. If the image is not level, rotate the leveling foot **D** on the left of the projector. To rotate the image clockwise, rotate the foot clockwise (as viewed from above).

## Adjusting zoom, focus and keystone

1. Use the Image-zoom control (on the projector only) to resize the projected image and screen size **A**.

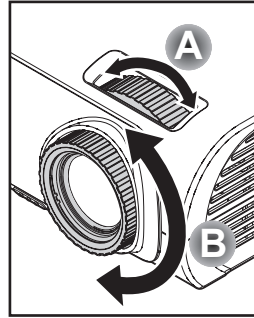

2. Use the Image-focus control (on the projector only) to sharpen the projected image **B**.
3. Press the Keystone +/- buttons on remote control. The keystone control appears on the display. (See page 15 to adjust keystone with the Quick Menu button on the projector.)

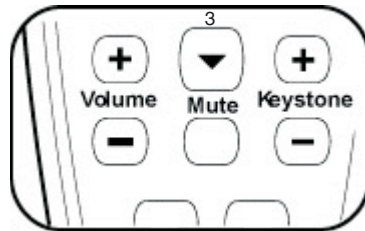

4. Use the Keystone +/- buttons to correct image distortion.



---

## Adjusting volume

1. Press the Volume +/- buttons on the remote control. The volume control appears on the display.

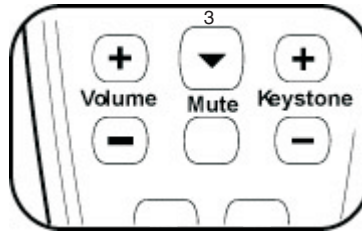

2. Use the Volume +/- buttons to adjust the level.



3. Press the Mute button to turn off the sounds.



---

## Adjusting with the projector quick menu button

Use the Quick Menu button on the projector to adjust brightness, contrast, volume, and keystone.

1. Press the Quick Menu button. The brightness control appears on the display.



2. Press the Quick Menu button repeatedly to scroll through the options contrast, volume, and keystone.



3. Use the left cursor/Source and Auto/cursor right buttons to adjust the value. The slider menu closes automatically.



---

## Chapter 3. On-screen display (OSD) menu settings

This section provides information on the On-screen display (OSD) menu settings.

---

### OSD menu controls

The projector has an OSD that lets you make image adjustments and change various settings.

**Note:** You must have a display on the screen in order to access the OSD.

### Navigating the OSD

You can use the remote control cursor buttons or the buttons on the top of the projector to navigate and make changes to the OSD. The following illustration shows the corresponding buttons on the remote control and on the projector.

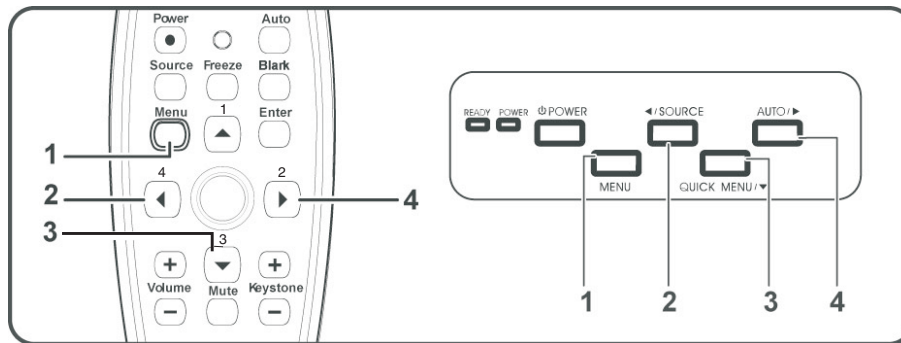

Item	Function
<b>1</b> Menu	Opens and closes the OSD.
<b>2</b> Left cursor button	Navigates and changes settings in the OSD menus.
<b>3</b> Up and down cursor buttons	Navigates and changes settings up and down in the OSD menus.
<b>4</b> Right cursor button	Navigates and changes settings in the OSD menus.

1. To open the OSD, press the **Menu** button.
2. There are six menus. Press the left or right cursor buttons to move through the menus.
3. Press the up or down cursor button to move up and down in a menu.
4. Press the left or right cursor buttons to change values for settings.
5. Press the up or down cursor buttons to select a different sub-menu item for change.
6. If you wish to cancel all changes made within a sub-menu, select Cancel and press the Enter button.
7. Press Menu to confirm the new setting and leave the sub-menu, or to close the OSD from the main menu screen.

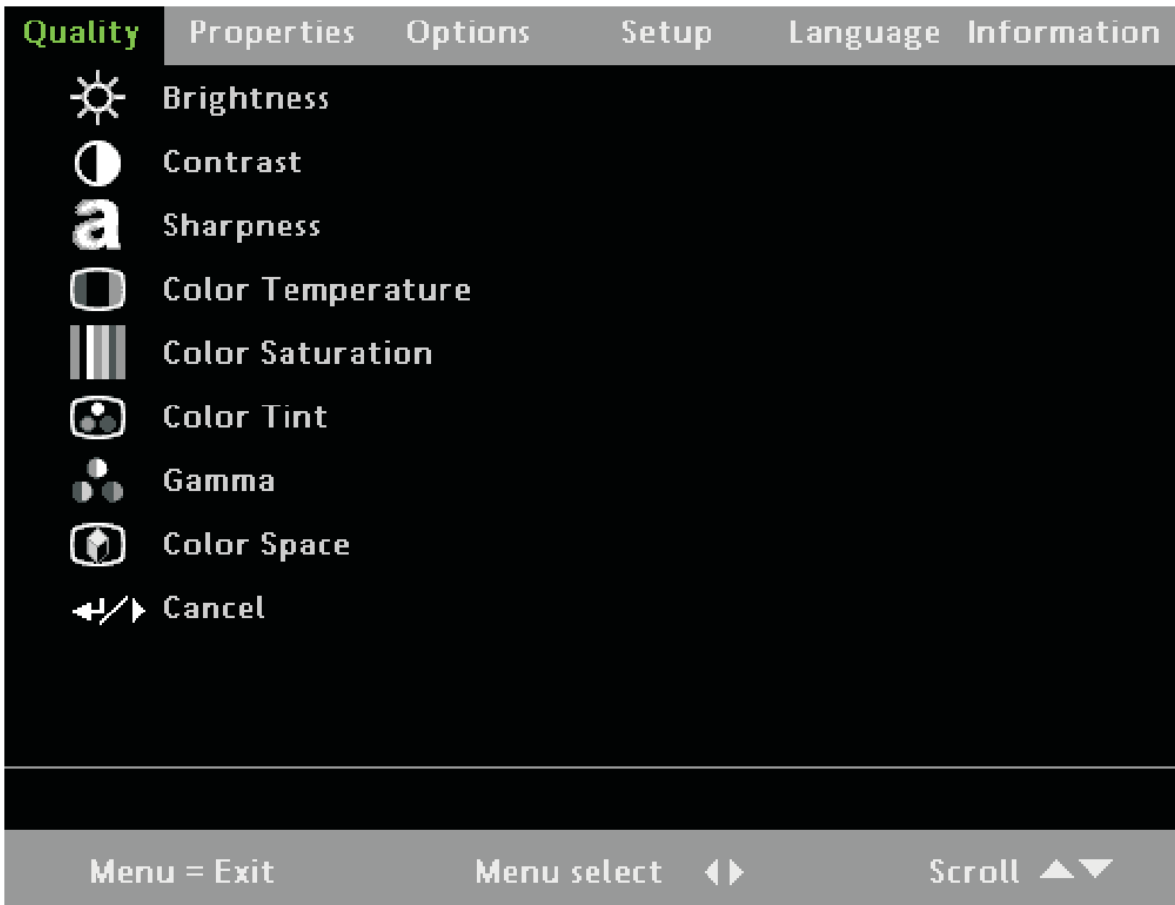

**Note:** Depending on the video source not all items in the OSD are available. For example, the Horizontal or Vertical Position items in the Properties menu can only be modified when connected to a PC. Items that are not available are grayed out and cannot be accessed.

---

## Setting the OSD language

You may want to reference the OSD on your projector while reading this section. Set the OSD language to your preference before continuing. The default language is English.

1. Press the menu button to open the OSD menu.

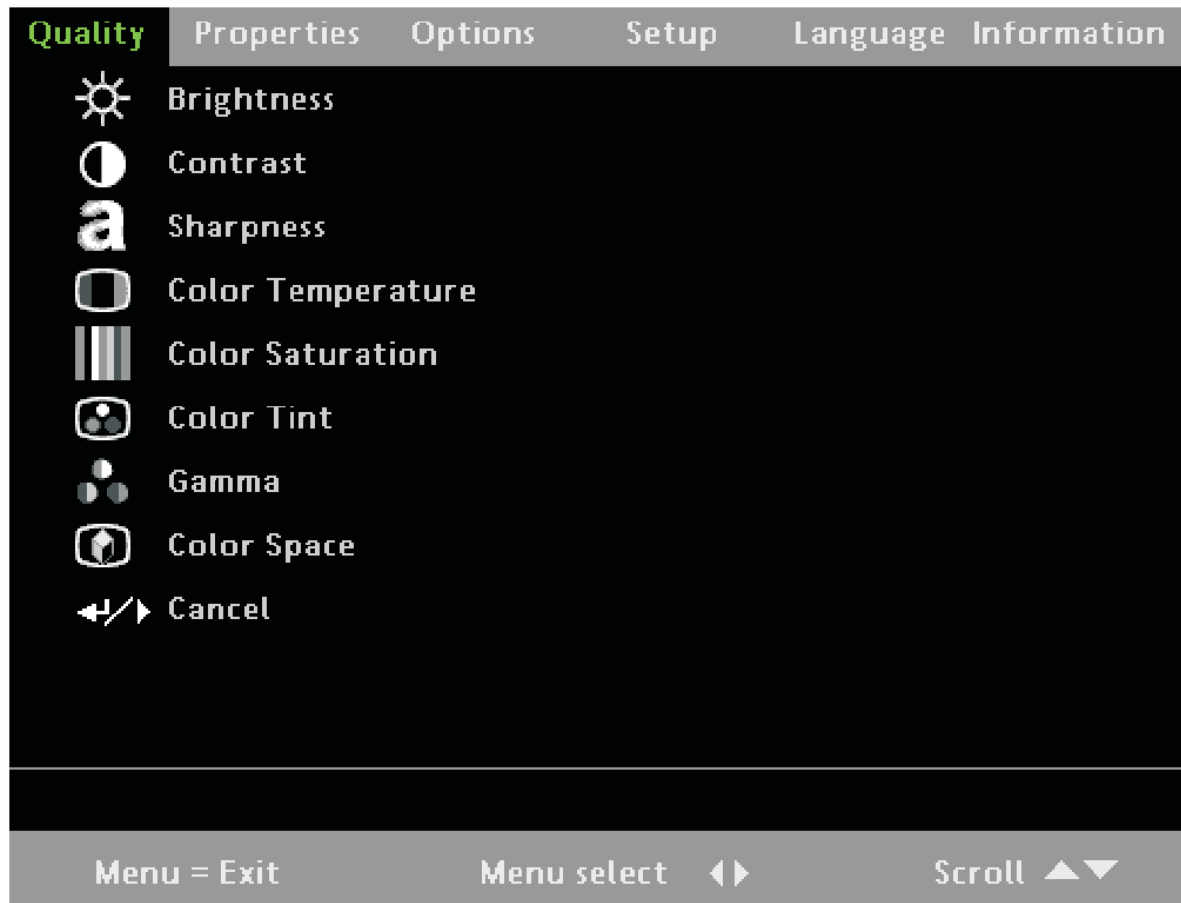

2. Press the left or right cursor button until **Language** is highlighted.
3. Press the up or down cursor button to highlight the desired language.
4. Press the cursor right cursor button or **Enter** to confirm the language.
5. Press **Menu** twice to close the OSD.

---

## Quality menu

1. Press the Menu button to open the OSD.
2. Press the left or right cursor buttons to move to the Quality menu.
3. Press the up or down cursor button to move up and down in the Quality menu.
4. Press the left or right cursor buttons to change values for settings.
5. Press the up or down cursor buttons to select a different Quality menu item for change.
6. If you wish to cancel all changes made within the Quality menu, select Cancel and press the Enter button.
7. Press Menu to confirm the new settings and leave the Quality menu.

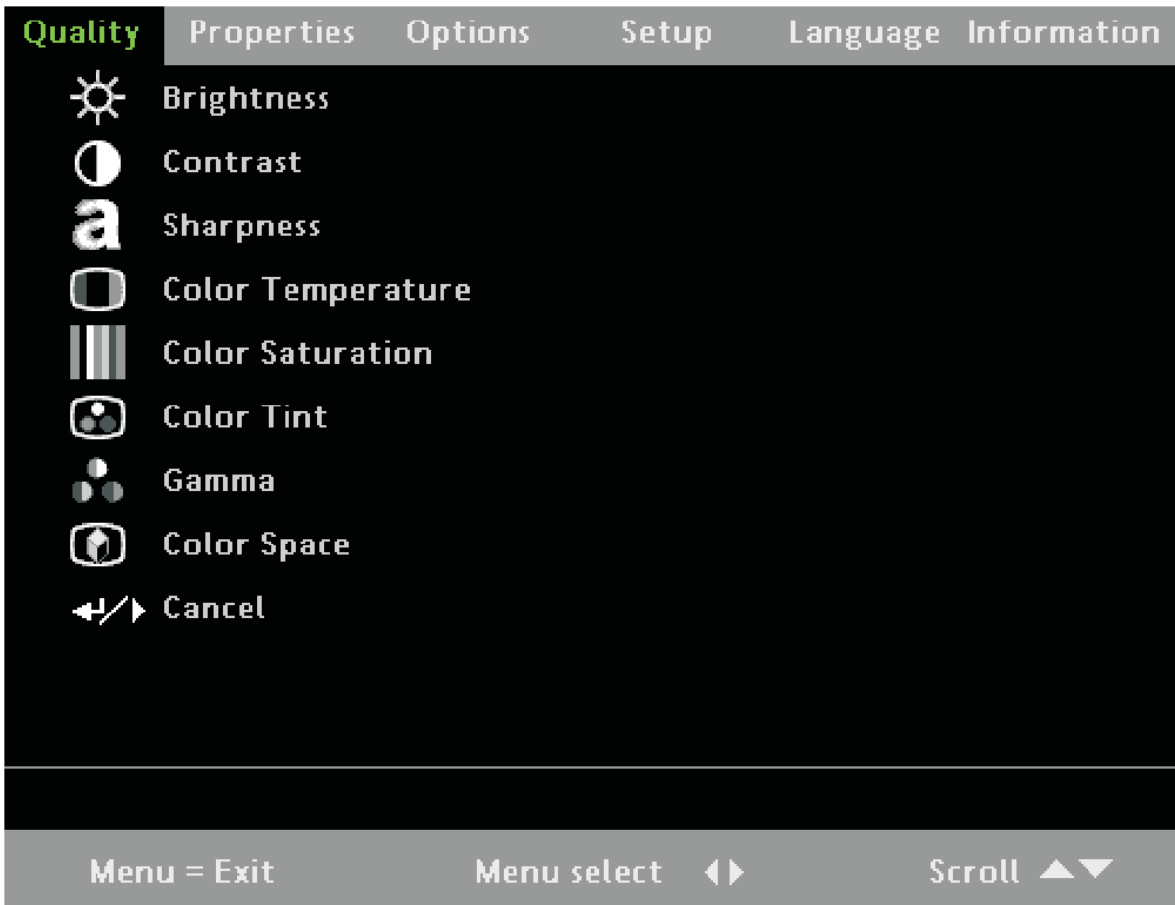

Item	Description	Default
Brightness	Press the left or right cursor button to adjust the brightness (range 0 - 100)	50
Contrast	Press the left or right cursor button to adjust the contrast (range 0 - 100)	50
Sharpness	Press the left or right cursor button to adjust the display sharpness (range 1 - 5)	3
Color temperature	Press the left or right cursor button to adjust the video tint/hue (range cool/normal/warm)	Normal
Color saturation	Press the left or right cursor button to adjust the video saturation (range 0 - 100)	50
Color tint	Press the left or right cursor button to adjust the video tint/hue (range 0 - 100)	50
Gamma	Press the left or right cursor button to adjust the gamma display correction (range: PC-MAC-Video-Chart-B&W)	PC
Color space	Press the left or right cursor button to adjust the color space (range: Auto - RGB - YPbPr - YCbCr)	Auto
Cancel	Return to previous menu.	n/a

### Quality menu functions available for connected source

Function	RGB	DVI-D	Component video	Composite video	S-video
Brightness	x	x	x	x	x
Contrast	x	x	x	x	x

Function	RGB	DVI-D	Component video	Composite video	S-video
Sharpness	x	x	x	x	x
Color temp	x	x	x	x	x
Color saturation			x	x	x
Color tint			x	x	x
Gamma	x	x	x	x	x
Color space	x	x	x	x	x
Cancel	x	x	x	x	x

x = available to video source

---

## Properties menu

1. Press the Menu button to open the OSD.
2. Press the left or right cursor buttons to move to the Properties menu.
3. Press the up or down cursor button to move up and down in the Properties menu.
4. Press the left or right cursor buttons to change values for settings.
5. Press the up or down cursor buttons to select a different Properties menu item for change.
6. If you wish to cancel all changes made within the Properties menu, select Cancel and press the Enter button.
7. Press Menu to confirm the new settings and leave the Properties menu.



Item	Description	Default
Horizontal position	Press the left or right cursor button to move the image left or right. (Range: 0 - 100)	50
Vertical position	Press the left or right cursor button to move the image up or down. (Range: 0 - 100)	50
Keystone correction	Press the left or right cursor button to correct distortion of the projected image.	0
Aspect ratio	Press the left or right cursor button to toggle between the 4:3 standard format and the 16:9 High Definition TV (HDTV) format	4:3
Advance feature	See "Advance features" on page 3-7.	n/a
Cancel	Return to previous menu.	n/a

### Properties menu functions available for connected source

Function	RGB	DVI-D	Component video	Composite video	S-video
Horizontal position	x				
Vertical position	x				
Keystone correction	x	x	x	x	x
Aspect ratio	x	x	x	x	x

Function	RGB	DVI-D	Component video	Composite video	S-video
Advance feature	x	x	x	x	x
Cancel	x	x	x	x	x

x = available to video source

## Advance features

1. Press the Menu button to open the OSD menu.
2. Press the up or down cursor buttons to move to the Properties menu.
3. Press the up or down cursor buttons to move to the Advance Feature menu and then press the Enter button.
4. Press the up or down cursor buttons to move up and down in the Advance Feature menu. Press the left or right cursor buttons to change values for settings. Press the up or down cursor buttons to select a different Advanced Feature menu item for change.
5. If you wish to cancel all changes made within the Advanced Feature menu, select Cancel and press the Enter button.
6. Press Menu to confirm the new settings and leave the Advanced Feature menu.

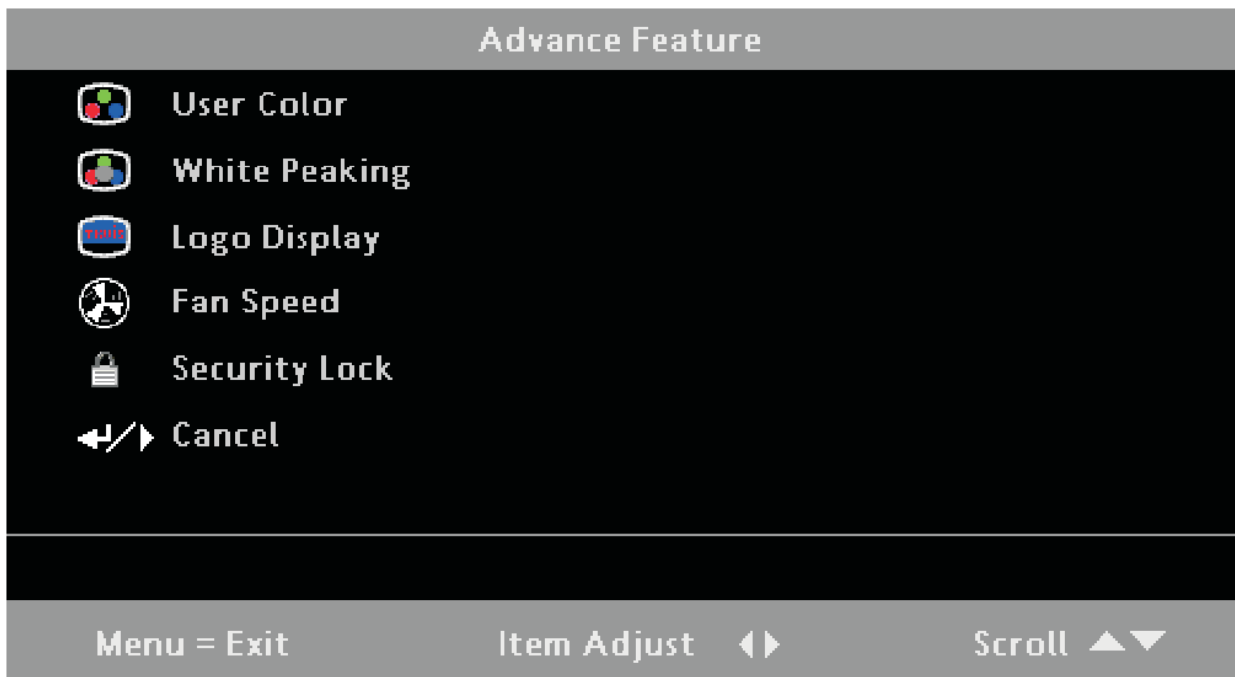

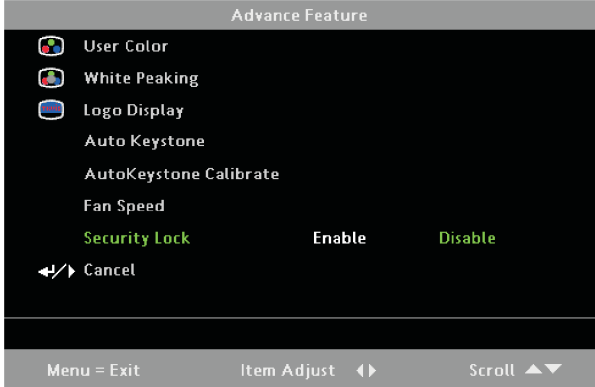
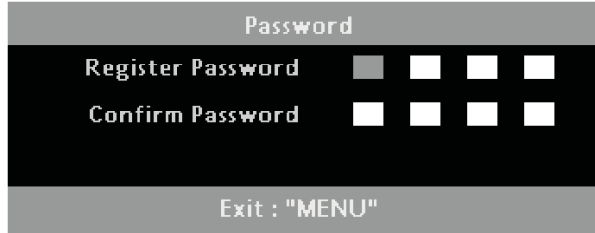
Item	Description	Default
User color	This feature adjusts the color balance in each color (red, green, blue, cyan, magenta, yellow and white) by using color correction adjustment. Increasing a color's setting heightens the intensity of that color on the screen, while a lower setting makes the color less intense. Press the up or down cursor button to select a color. Press the left or right cursor button to adjust the selected color (range: 0 - 100).	80
White peaking	White Peaking increases the output in the brightest whites without changing the blacks and dark grays. Higher settings may cause very bright shades of gray to saturate. For a smoother, more natural image, use lower settings. Press the left or right cursor button to adjust the value of white peaking (range: 0 - 10).	Data source: 10 Video source: 2
Logo display	Press the left or right cursor button to enable or disable if the logo displays when the projector starts, and when no source is detected (range: On - Off).	on
Fan speed	Press the left or right cursor button to toggle between Normal and High fan speeds.	normal
Security lock	<p>Press the left or right cursor button to enable or disable Security Lock.</p>  <p>When you enable the security lock, the Register Password dialog box appears:</p>  <p>You can use the cursor buttons numbered 1, 2, 3, and 4 on the remote to enter the password. You can use any combination including the same number multiple times, but the password must be four characters. After entering the password a second time to confirm it, OK displays. When the password is enabled, it must be entered every time after you power on the projector. See "Setting access passwords (security lock)" on page 2-4 for steps on setting the password.</p>	no password
Cancel	Return to previous menu.	n/a

**Note:** If Security Lock is enabled, you must enter the password every time the projector is turned on. However, if the projector is already turned on, Security Lock can be disabled without having to enter the current password.

## User Color

1. Press the Menu button to open the OSD menu.
2. Press the left or right cursor buttons to move to the Properties menu. Press the up or down cursor buttons to move to the Advance Feature menu.



3. Press the up or down cursor buttons to move to the User Color menu and then press the Enter button.
4. Press the up or down cursor buttons to move up and down in the User Color menu. Press the left or right cursor buttons to change values for settings. Press the up or down cursor buttons to select a different User Color menu item for change.
5. If you wish to cancel all changes made within the User Color menu, select Cancel and press the Enter button. Press Menu to confirm the new settings and leave the User Color menu.



Item	Description	Default
Colors	Press the left or right cursor button to adjust the color levels. (Range: 0 - 100)	80
Cancel	Return to previous menu	n/a

## Options menu

1. Press the Menu button to open the OSD.
2. Press the left or right cursor buttons to move to the Options menu.
3. Press the up or down cursor button to move up and down in the Options menu.
4. Press the left or right cursor buttons to change values for settings.
5. Press the up or down cursor buttons to select a different Options menu item for change.
6. If you wish to cancel all changes made within the Options menu, select Cancel and press the Enter button.
7. Press Menu to confirm the new settings and leave the Options menu.

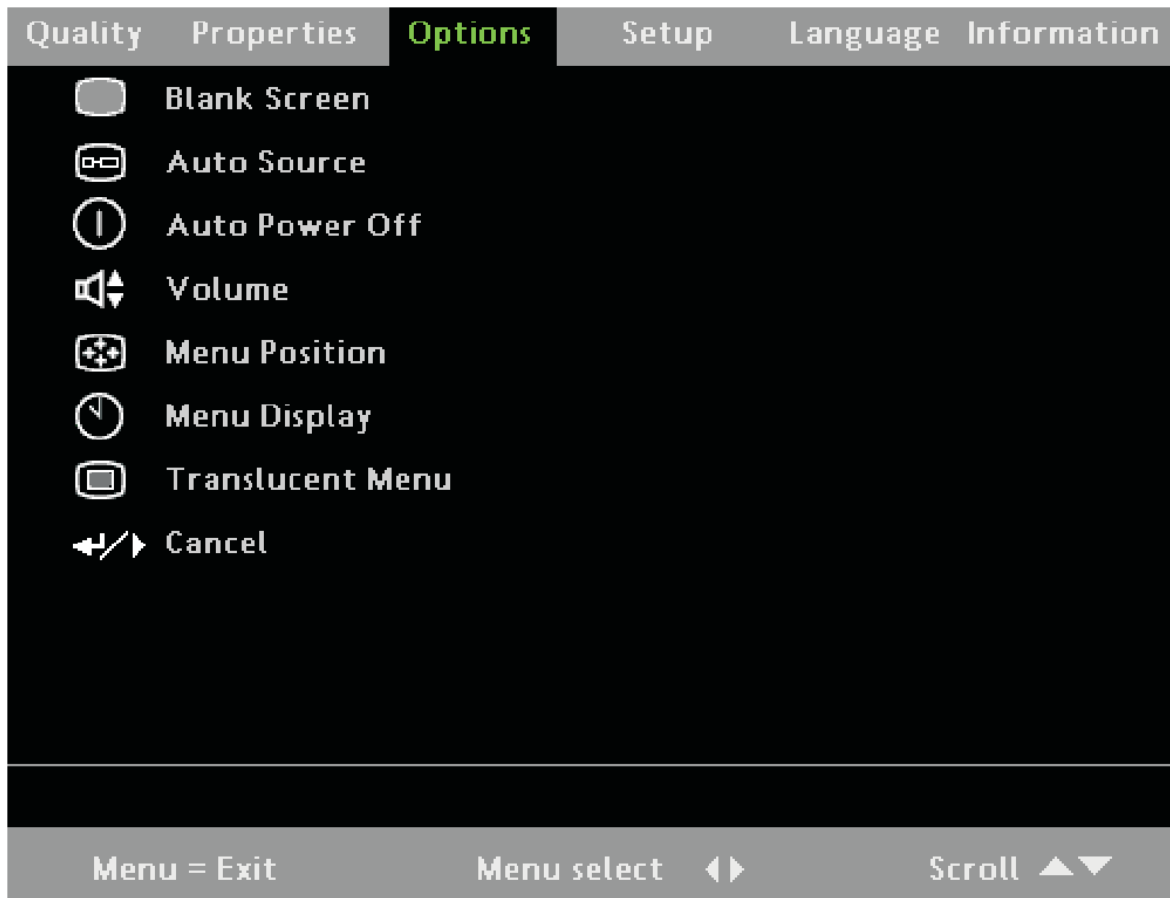

Item	Description	Default
Blank screen	Press the left or right cursor button to select a background color for the blank screen. (Range: Black - Red - Green - Blue - White)	blue
Auto source	Press the left or right cursor button to enable or disable automatic source detection. (Range: On - Off)	on
Auto power off	Press the left or right cursor button to enable or disable automatic shutdown of lamp after 10 minutes of inactivity. (Range: On - Off)	off
Volume	Press the left or right cursor button to adjust the audio volume level. (Range: 0 - 8)	off
Menu position	Press the left or right cursor button to position the OSD on screen. (Range: Left - Right - Center - Down - Up)	center
Menu display	Press the left or right cursor button to determine the timeout delay of the OSD. (Range: 10 - 20 sec.)	15

Translucent menu	Press the left or right cursor button to set menu screen translucency. (Range: 0% - 100%)	0%
Cancel	Return to previous menu	n/a

**Note:** The Options menu functions are available to all video sources.

## Setup menu

1. Press the Menu button to open the OSD.
2. Press the left or right cursor buttons to move to the Setup menu.
3. Press the up or down cursor button to move up and down in the Setup menu.
4. Press the left or right cursor buttons to change values for settings.
5. Press the up or down cursor buttons to select a different Setup menu item for change.
6. If you wish to cancel all changes made within the Setup menu, select Cancel and press the Enter button.
7. Press Menu to confirm the new settings and leave the Setup menu.

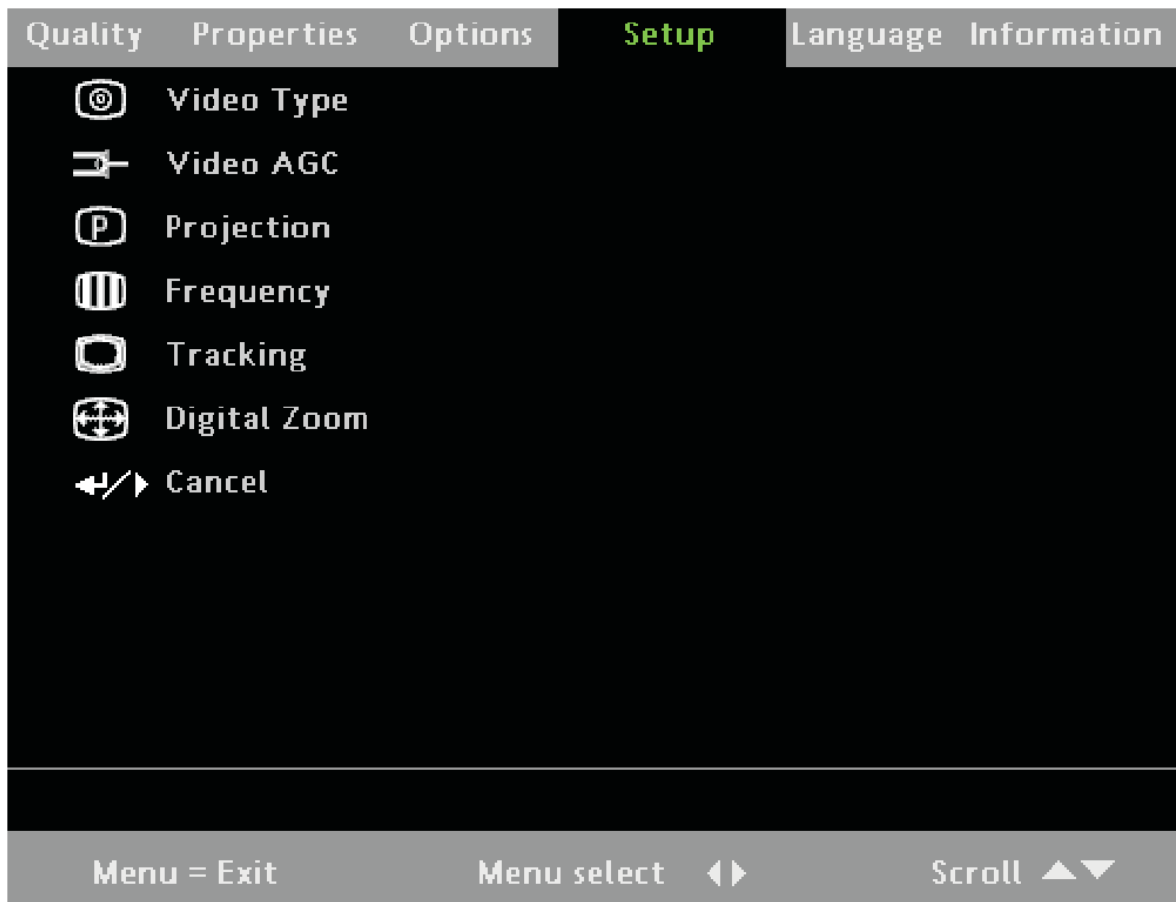

Item	Description	Default
Video type	Press the left or right cursor button to select the video standard. (Range: Auto - NTSC - PAL - SECAM)	auto
Video AGC	Press the left or right cursor button to enable or disable automatic gain control for the video source. (Range: On - Off)	on
Projection	Press the left or right cursor button to choose from front or rear projection	Desktop front
Frequency	Press the left or right cursor button to adjust the A/D sampling clock (in degrees. (Range: 0 - 180)	Auto detected
Tracking	Press the left or right cursor button to adjust the A/D sampling number. (Range: 1 - 100)	Auto detected
Digital zoom	<p>Digital operation for zoom and pan adjustment. Press Enter or the right cursor button. The Zoom menu appears.</p> <div style="border: 1px solid black; background-color: #cccccc; padding: 10px; text-align: center; margin: 10px auto; width: fit-content;"> <p><b>Zoom : ▲▼</b></p> <p><b>Pan : "Enter"</b></p> <p><b>Exit : "MENU"</b></p> </div> <p>Press the up cursor to zoom in; press the down cursor to zoom out. Press Enter or the right cursor to open the Pan menu. You must zoom in before you can open the Pan menu. Use the cursor buttons to pan the zoomed image. Press the Menu button to exit.</p>	n/a
Cancel	Return to previous menu.	n/a

## Setup menu functions available for connected source

Function	RGB	DVI-D	Component video	Composite video	S-video
Video type				x	x
Video AGC				x	x
Projection	x	x	x	x	x
Frequency	x		x		
Tracking	x				
Digital zoom	x		x	x	x
Cancel	x	x	x	x	x

## Language menu

1. Press the Menu button to open the OSD menu.
2. Press the left or right cursor buttons to move to the Language menu.
3. Press the up or down cursor buttons to move up and down in the Language menu.
4. Press the left or right cursor buttons to change values for settings.
5. Press the up or down cursor buttons to select a different Language menu for change.
6. If you wish to cancel all changes made within the Language menu, select Cancel and press the Enter button.
7. Press Menu to confirm the new settings and leave the Language menu.



---

## Information menu

1. Press the Menu button to open the OSD menu.
2. Press the left or right cursor buttons to move to the Information menu.
3. Press the up or down cursor buttons to move up and down in the Information menu.
4. Press the left or right cursor buttons to change values for settings.
5. Press the up or down cursor buttons to select a different Information menu item for change.
6. If you wish to cancel all changes made within the Information menu, select Cancel and press the Enter button.
7. Press Menu to confirm the new settings and leave the Information menu.

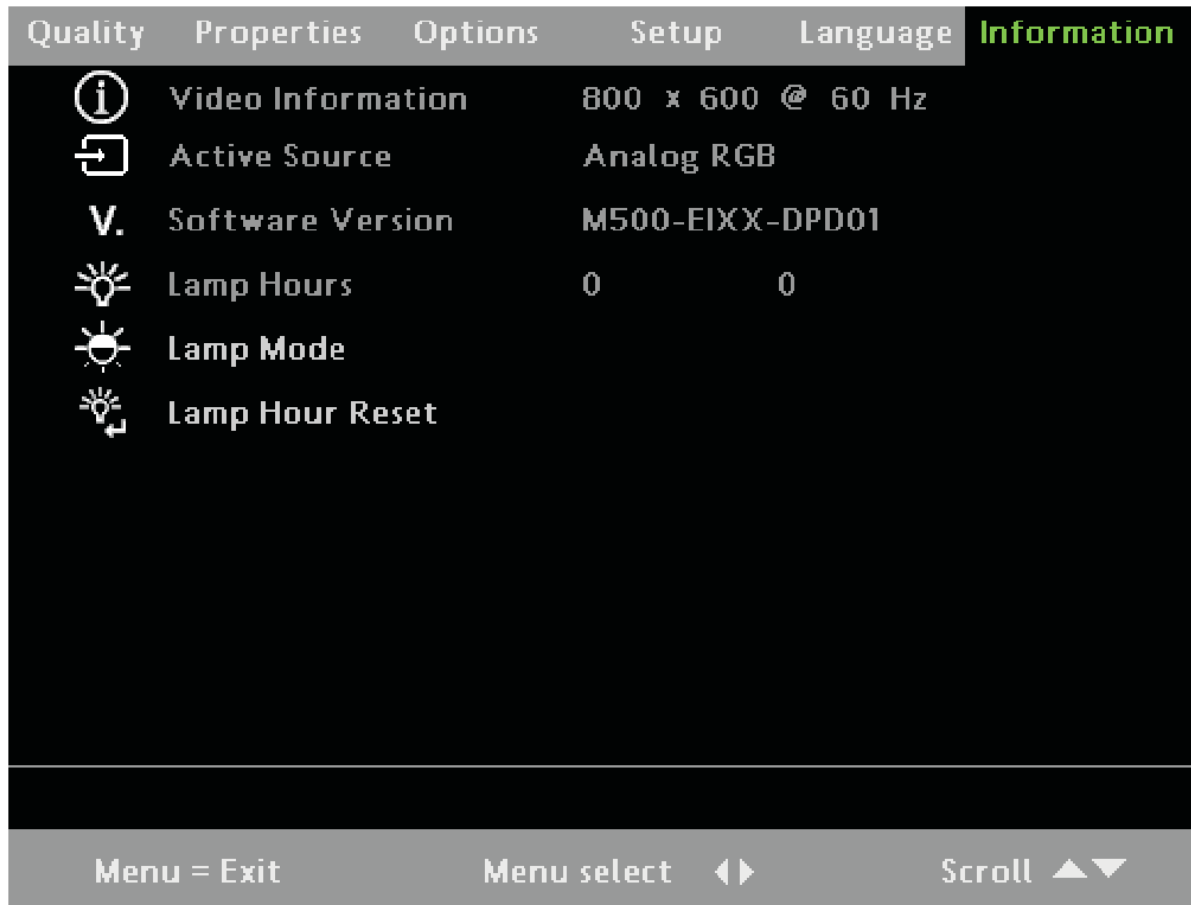

Item	Description	Default
Video information	Displays the resolution and refresh rate for RGB/DVI mode. Displays the color standard for video mode.	Display only
Active source	Displays the active source.	Display only
Software version	Displays information about the software version.	Display only
Lamp hours	Shows the number of hours lamp has been in use for Eco and Normal modes.	Display only
Lamp mode	Press the left or right cursor button to choose the lamp mode (Range: Eco; Normal). Eco mode uses less power and extends lamp life, but decreases lamp brightness.	normal
Lamp hour reset	After replacing the lamp, this item should be reset. Refer to "Replacing the projection lamp" on page A-1.	n/a

---

## Appendix A. Maintenance

This chapter provides information on projector maintenance.

---

### Replacing the projection lamp

The projection lamp should be replaced when it burns out. It should only be replaced with a certified replacement part, which you can order from your local dealer.

**Attention:** This product contains a metal arc lamp, which contains a small amount of mercury. Dispose of it as required by local ordinances and regulations. Avoid touching the glass surface of the new lamp. Doing so may shorten its operation life. The USA restricts or prohibits the disposal of some or all lamps containing mercury in the municipal waste stream. Please visit <http://www.lamprecycle.org> for more information on specific state disposal requirements and recycling facilities. For users in Connecticut, please call Northeast Lamp Recycling toll-free at 1 (888) 657-5267 to place an order for the delivery of a kit that includes a box for the lamp, tape, and a return shipping label.

**Attention:** Be sure to turn off and unplug the projector at least an hour before replacing the lamp.

1. Loosen the two captive screws on the lamp compartment cover **A**.
2. Remove the lamp compartment cover **B**.

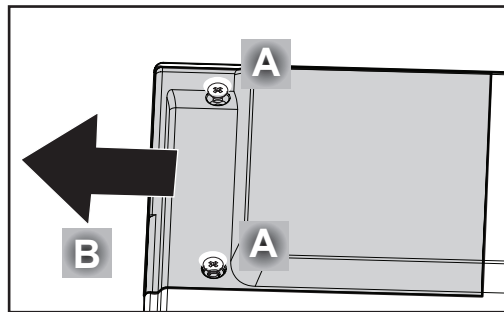

3. Remove the two screws from the lamp module **A**.
4. Lift the module handle up **B**.

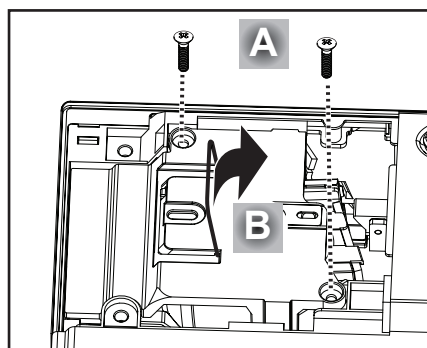

5. Pull firmly on the module handle to remove the lamp module.

6. Reverse steps 1 to 5 to install the new lamp module.

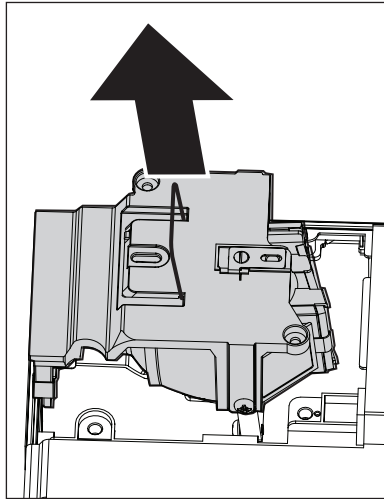

## Resetting the lamp

After replacing the lamp, you should reset the lamp hour counter to zero. Refer to the following:

1. Press the Menu button to open the Main menu.
2. Press the left or right cursor button to move to the Information menu.
3. Press the up or down cursor button to move down to Lamp Hour Reset.

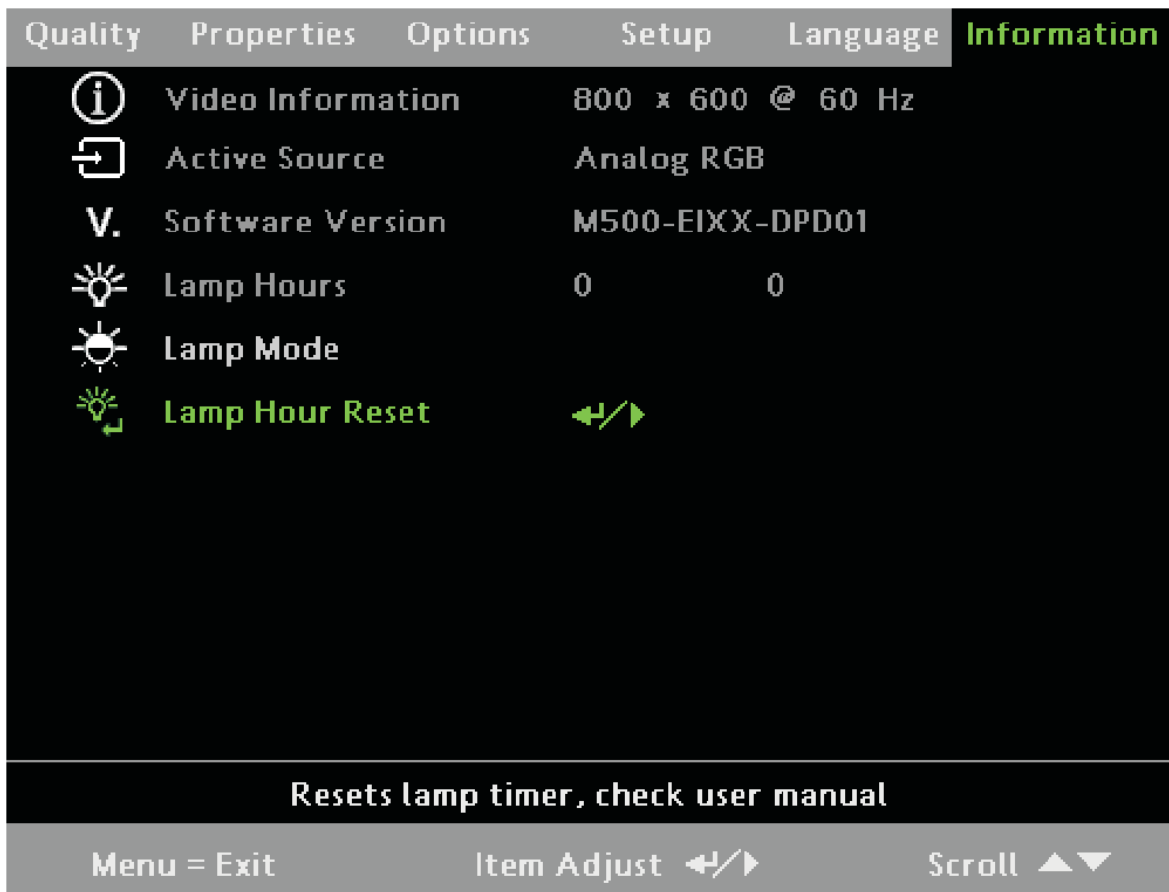



4. Press the up or down cursor button or the Enter button. A message screen appears.



5. Using the remote, press the cursor buttons in this order: down, up, left, right. The Status menu displays the Lamp Hours reset to zero.

---

## Cleaning the projector

Cleaning the projector to remove dust and grime will help ensure trouble-free operation.

**Attention:** Be sure to turn off and unplug the projector at least an hour before cleaning. Use only a dampened cloth when cleaning. Do not allow water to enter the ventilation openings on the projector. If any water gets into the projector interior while cleaning, leave unplugged in a well-ventilated room for several hours before using. If a lot of water gets into the projector interior when cleaning, have the projector serviced.

### Cleaning the lens

You can purchase optic lens cleaner from most camera stores. Refer to the following to clean the projector lens.

1. Apply a little optic lens cleaner to a clean soft cloth. (Do not apply the cleaner directly to the lens.)
2. Lightly wipe the lens in a circular motion.

**Attention:** Do not use abrasive cleaners or solvents. To prevent discoloration or fading, avoid getting cleaner on the projector case.

### Cleaning the case

Refer to the following to clean the projector case.

1. Wipe off dust with a clean dampened cloth.
2. Moisten the cloth with warm water and mild detergent (such as used to wash dishes), and then wipe the case.
3. Rinse all detergent from the cloth and wipe the projector again.

**Attention:** To prevent discoloration or fading of the case, do not use abrasive alcohol-based cleaners.

---

## Using the Kensington lock

If you are concerned about security, attach the projector to a permanent object with the Kensington slot and a security cable.

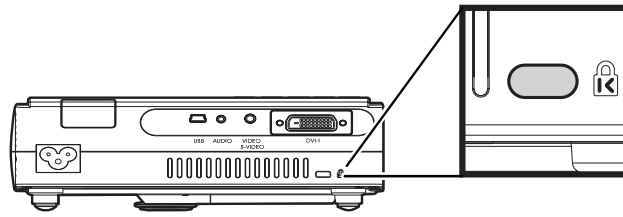

**Note:** Contact Lenovo for details on purchasing a suitable Kensington security cable.

---

## Appendix B. Troubleshooting

The following table provides troubleshooting information for the projector. In some cases, more than one possible solution is provided. Try the solutions in the order they are presented. When the problem is solved, you can skip the additional solutions.

---

### Common problems and solutions

These guidelines provide tips to deal with problems you may encounter while using the projector. If the problem remains unsolved, contact your dealer for assistance. Often after time spent troubleshooting, the problem is traced to something as simple as a loose connection. Check the following before proceeding to the problem-specific solutions.

- Use some other electrical device to confirm that the electrical outlet is working. Ensure that:
  - the projector is turned on.
  - all connections are securely attached.
  - that the attached device is turned on.
  - a connected PC is not in suspend mode.
  - a connected notebook computer is configured for an external display. This is usually done by pressing a Function key combination on the notebook.

---

### Troubleshooting tips

In each problem-specific section, try the steps in the order suggested. This may help you to solve the problem more quickly. Try to pinpoint the problem and avoid replacing non-defective parts. For example, if you replace batteries and the problem still exists, put the original batteries back and go to the next step. Keep a record of the steps you take when troubleshooting: The information may be useful when calling for technical support or for passing on to service personnel.

---

### LED error messages

LED	Status/Number of flashes	Description
Ready	Flashing	Lamp not ready - do not press the power button
	1	Fan 1 error
	2	Fan 2 error
Power	2	System task created error
	3	System overheating
	4	System interface error
	5	Lamp error
	6	Fan error (refer to Ready LED status to determine which fan)
	7	Lamp cover open
	8	DLP driver error
	9	Color wheel error

## Image problems

Issue	Solution(s)
<i>No image appears on the screen.</i>	<ol style="list-style-type: none"><li>1. Verify the settings on your notebook or desktop PC.</li><li>2. Turn off all equipment and power up again in the correct order.</li></ol>
<i>The image is blurred.</i>	<ol style="list-style-type: none"><li>1. Adjust the Focus on the projector.</li><li>2. Press the Auto button on the remote control or projector.</li><li>3. Ensure that the projector-to-screen distance is within the 10-meter (33-feet) specified range.</li><li>4. Check that the projector lens is clean.</li></ol>
<i>The image is wider at the top or bottom (trapezoid effect).</i>	<ol style="list-style-type: none"><li>1. Position the projector so it is as perpendicular to the screen as possible.</li><li>2. Use the Keystone button on the remote control or projector to correct the problem.</li></ol>
<i>The image is reversed.</i>	<ol style="list-style-type: none"><li>1. Check the Projection setting on the Setup menu of the OSD.</li></ol>
<i>The image is streaked.</i>	<ol style="list-style-type: none"><li>1. Set the Frequency and Tracking settings on the Setup menu of the OSD to the default settings.</li><li>2. To ensure the problem is not caused by a connected PC's video card, connect to another computer.</li></ol>
<i>The image is flat with no contrast.</i>	<ol style="list-style-type: none"><li>1. Adjust the Contrast setting on the Quality menu of the OSD.</li></ol>
<i>The color of the projected image does not match the source image.</i>	<ol style="list-style-type: none"><li>1. Adjust the Color Temperature and Gamma settings on the Quality menu of the OSD.</li></ol>

## Lamp problems

Issue	Solution(s)
<i>There is no light from the projector.</i>	<ol style="list-style-type: none"><li>1. Check that the power cable is securely connected.</li><li>2. Ensure the power source is good by testing with another electrical device.</li><li>3. Restart the projector in the correct order and check that the Power LED is green.</li><li>4. If you have recently replaced the lamp, try resetting the lamp connections.</li><li>5. Replace the lamp module.</li></ol>
<i>The lamp turns off.</i>	<ol style="list-style-type: none"><li>1. Power surges can cause the lamp to turn off. Press the power button twice to turn off the projector. When the Ready LED is on, press the power button.</li><li>2. Replace the lamp module.</li></ol>

---

## Remote control problems

Issue	Solution(s)
<i>The projector does not respond to the remote control.</i>	<ol style="list-style-type: none"><li>1. Direct the remote control towards remote sensor on the projector.</li><li>2. Ensure that the path between remote and sensor is not obstructed.</li><li>3. Turn off any fluorescent lights in the room.</li><li>4. Check the battery polarity.</li><li>5. Replace the batteries.</li><li>6. Turn off other Infrared-enabled devices in the vicinity.</li></ol>

---

## Audio problems

Issue	Solution(s)
<i>There is no sound.</i>	<ol style="list-style-type: none"><li>1. Adjust the volume on the remote control</li><li>2. Adjust the volume of the audio source.</li><li>3. Check the audio cable connection.</li><li>4. Test the source audio output with other speakers.</li></ol>
<i>The sound is distorted.</i>	<ol style="list-style-type: none"><li>1. Check the audio cable connection.</li><li>2. Test the source audio output with other speakers.</li></ol>

---

## Servicing the projector

If you are unable to solve the problem, you should have the projector serviced. For details on obtaining service, go to Appendix D, "Service and Support," on page D-1.



---

## Appendix C. Specifications

This section provides information on product specifications.

---

### Specifications

Display type	TI DMD 0.7-inch x 1, 12 degrees, DDR DLP with DDP 2000 ASIC controller
Resolution	XGA 1024 x 768 native
Color	16.7 Million (24-bits/pixel)
Bandwidth	Up to 140 MHz
Weight	1.1 kg (2.5 lbs.)
Projection distance	1.5 to 10 meters (59 to 394 inches)
Projection screen size	0.9 to 4.9 meters (35 to 191 inches)
Projection lens	Manual and digital zoom; manual focus
Zoom ratio	1.16
Vertical keystone correction	+/- 15
Projection methods	Desktop front/rear
Data compatibility	IBM PC or compatibles up to SXGA+, Mac
SDTV/EDTV/HDTV	480i, 576i/480p, 576p/720p, 1080i
Video compatibility	NTSC/NTSC 4.43, PAL (B/G/H/I/M/N 60), SECAM
H-sync	15,31 - 90 kHz
V-sync	50 - 85 Hz
Safety certification	FCC Class B, UL, C-UL, CE, CB, TUV-CB, CCC
Operation temperature	5° to 35° C (41° to 95° F) at sea level -10° to 60° C (14° to 140° F) (non-operating)
Dimensions	195 x 162 x 53 mm (7.7 x 6.4 x 2.1 in.)
Power consumption	Typical 190W (normal mode); Typical 165W (ECO mode)
Lamp power consumption	Typical 156W (normal mode); Typical 136W (ECO mode)
Stand by	< 8 watts
Audio speaker	0.5W mono speaker
Altitude (operating) Altitude (non-operating)	3,048 m (0 to 10,000 ft) 12,192 m (0 to 40,000 ft)
Humidity (operating) Humidity (non-operating)	5% to 90% relative humidity, non-condensing 5% to 95% relative humidity, non-condensing
Input power requirements	100 - 240 V 1.8A 50/60 Hz

## Projection distance vs. projection size

Shaded rows are equivalent measurement in feet and inches.

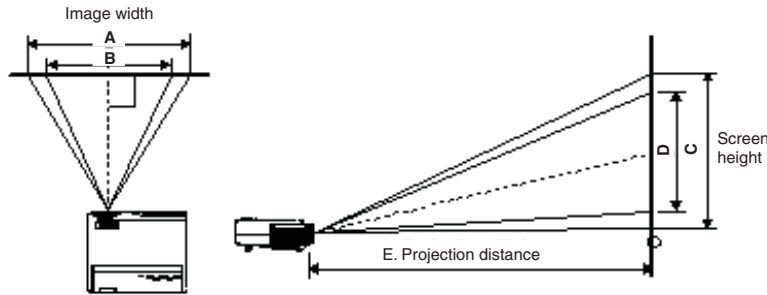

Projection Distance	Diagonal Max	Width Max	Height Max	Diagonal Min	Width Min	Height Min
E		A	C		B	D
1.00 m	0.69 m	0.56 m	0.42 m	0.60 m	0.48 m	0.36 m
3.28'	27.34"	21.87"	16.40"	23.43"	18.75"	14.06"
1.50 m	1.04 m	0.83 m	0.63 m	0.89 m	0.71 m	0.54 m
4.92'	41.01"	32.81"	24.61"	35.15"	28.12"	21.09"
2.40 m	1.67 m	1.33 m	1.00 m	1.43 m	1.14 m	0.86 m
7.87'	65.62"	52.49"	39.37"	56.24"	44.99"	33.75"
2.80 m	1.94 m	1.56 m	1.17 m	1.67 m	1.33 m	1.00 m
9.18'	76.55"	61.24"	45.93"	65.62"	52.49"	39.37"
3.20 m	2.22 m	1.78 m	1.33 m	1.90 m	1.52 m	1.14 m
10.50'	87.49"	69.99"	52.49"	74.99"	59.99"	44.99"
3.60 m	2.50 m	2.00 m	1.50 m	2.14 m	1.71 m	1.29 m
11.81'	98.43"	78.74"	59.06"	84.36"	67.49"	50.62"
4.00 m	2.78 m	2.22 m	1.67 m	2.38 m	1.90 m	1.43 m
13.12'	109.36"	87.49"	65.62"	93.74"	74.99"	56.24"
4.40 m	3.06 m	2.44 m	1.83 m	2.62 m	2.10 m	1.57 m
14.43'	120.30"	96.24"	72.18"	103.11"	82.49"	61.87"
4.80 m	3.33 m	2.67 m	2.00 m	2.86 m	2.29 m	1.71 m
15.74'	131.23"	104.99"	78.74"	112.49"	89.99"	67.49"
5.20 m	3.61 m	2.89 m	2.17 m	3.10 m	2.48 m	1.86 m
17.06'	142.17"	113.74"	85.30"	121.86"	97.49"	73.12"
5.60 m	3.89 m	3.11 m	2.33 m	3.33 m	2.67 m	2.00 m
18.37'	153.11"	122.48"	91.86"	131.23"	104.99"	78.74"
7.00 m	4.86 m	3.89 m	2.92 m	4.17 m	3.33 m	2.50 m
22.96'	191.38"	153.11"	114.83"	164.04"	131.23"	98.43"
10.00 m	6.94 m	5.56 m	4.17 m	5.95 m	4.76 m	3.57 m
32.80'	273.40"	218.72"	164.04"	234.35"	187.48"	140.61"



## Timing mode table

The projector can display several resolutions. The following table outlines the resolutions that can be displayed by the projector.

Signal	Resolution	Frequency H. (KHz)	Frequency V. (Hz)	Video	Digital	Analog
NTSC	-	15.734	60.0	Yes	No	No
PAL/SECAM	-	15.625	50.0	Yes	No	No
VESA	640 x 350	37.9	85.1	No	Yes	Yes
	720 x 400	31.5	70.0	No	Yes	Yes
	720 x 400	37.9	85.0	No	Yes	Yes
	640 x 480	31.5	60.0	No	Yes	Yes
	640 x 480	37.9	72.8	No	Yes	Yes
	640 x 480	37.5	75.0	No	Yes	Yes
	640 x 480	43.3	85.0	No	Yes	Yes
	800 x 600	37.9	60.3	No	Yes	Yes
	800 x 600	46.9	75.0	No	Yes	Yes
	800 x 600	48.1	72.2	No	Yes	Yes
	800 x 600	53.7	85.1	No	Yes	Yes
	1024 x 768	48.4	60.0	No	Yes	Yes
	1024 x 768	56.5	70.1	No	Yes	Yes
	1024 x 768	60.0	75.0	No	Yes	Yes
	1024 x 768	68.7	85.0	No	Yes	Yes
Apple Macintosh	640 x 480	35.0	66.7	No	Yes	Yes
	832 x 624	49.7	74.5	No	Yes	Yes
	1024 x 768	60.2	74.9	No	Yes	Yes
	1152 x 870	68.7	75.1	No	Yes	Yes
HDTV	1920 x 1080	33.8	30.0	Yes	No	No
	1920 x 1080	28.1	25.0	Yes	No	No
	1280 x 720	45.0	60.0	Yes	No	No
SDTV	720 x 576	31.3	50.0	Yes	No	No
	720 x 480	31.3	60.0	Yes	No	No



---

## Appendix D. Service and Support

The following information describes the technical support that is available for your product, during the warranty period or throughout the life of the product. Refer to your Lenovo Statement of Limited Warranty for a full explanation of Lenovo warranty terms.

---

### Online technical support

Online technical support is available during the life of your product through the Lenovo Support Web site at <http://www.lenovo.com/support>.

During the warranty period, assistance for replacement or exchange of defective components is available. In addition, if your option is installed in a Lenovo computer, you might be entitled to service at your location. Your technical support representative can help you determine the best alternative.

---

### Telephone technical support

Installation and configuration support through the Customer Support Center will be withdrawn or made available for a fee, at Lenovo's discretion, 90 days after the option has been withdrawn from marketing. Additional support offerings, including step-by-step installation assistance, are available for a nominal fee.

To assist the technical support representative, have available as much of the following information as possible:

- Option name
- Option number
- Proof of purchase
- Computer manufacturer, model, serial number, and manual
- Exact wording of the error message (if any)
- Description of the problem
- Hardware and software configuration information for your system

If possible, be at your computer. Your technical support representative might want to walk you through the problem during the call.

For a list of Service and Support phone numbers, see "Worldwide telephone list" on page E-14. Phone numbers are subject to change without notice. For the most current phone numbers, go to <http://www.lenovo.com/support> and click **Support phone list**. If the number for your country or region is not listed, contact your reseller or Lenovo marketing representative.



---

# Appendix E. Lenovo Statement of Limited Warranty

LSOLW-00 05/2005

---

## Part 1 - General Terms

*This Statement of Limited Warranty includes Part 1 - General Terms, Part 2 - Country-unique Terms, and Part 3 - Warranty Information. The terms of Part 2 replace or modify those of Part 1. The warranties provided by Lenovo Group Limited or one of its subsidiaries (called "Lenovo") in this Statement of Limited Warranty apply only to Machines you purchase for your use, and not for resale. The term "Machine" means a Lenovo machine, its options, features, conversions, upgrades or peripheral products, or any combination of them. The term "Machine" does not include any software programs, whether pre-loaded with the Machine, installed subsequently or otherwise. **Nothing in this Statement of Limited Warranty affects any statutory rights of consumers that cannot be waived or limited by contract.***

### What this Warranty Covers

Lenovo warrants that each Machine 1) is free from defects in materials and workmanship and 2) conforms to Lenovo's Official Published Specifications ("Specifications") which are available on request. The warranty period for the Machine starts on the original date of installation and is specified in Part 3 - Warranty Information. The date on your invoice or sales receipt is the date of installation unless Lenovo or your reseller informs you otherwise. Unless Lenovo specifies otherwise, these warranties apply only in the country or region in which you purchased the Machine.

**THESE WARRANTIES ARE YOUR EXCLUSIVE WARRANTIES AND REPLACE ALL OTHER WARRANTIES OR CONDITIONS, EXPRESS OR IMPLIED, INCLUDING, BUT NOT LIMITED TO, THE IMPLIED WARRANTIES OR CONDITIONS OF MERCHANTABILITY AND FITNESS FOR A PARTICULAR PURPOSE. SOME STATES OR JURISDICTIONS DO NOT ALLOW THE EXCLUSION OF EXPRESS OR IMPLIED WARRANTIES, SO THE ABOVE EXCLUSION MAY NOT APPLY TO YOU. IN THAT EVENT, SUCH WARRANTIES ARE LIMITED IN DURATION TO THE WARRANTY PERIOD. NO WARRANTIES APPLY AFTER THAT PERIOD. SOME STATES OR JURISDICTIONS DO NOT ALLOW LIMITATIONS ON HOW LONG AN IMPLIED WARRANTY LASTS, SO THE ABOVE LIMITATION MAY NOT APPLY TO YOU.**

### What this Warranty Does not Cover

This warranty does not cover the following:

- any software programs, whether pre-loaded or shipped with the Machine, or installed subsequently;
- failure resulting from misuse, accident, modification, unsuitable physical or operating environment, or improper maintenance by you;
- failure caused by a product for which Lenovo is not responsible; and
- any non-Lenovo products, including those that Lenovo may procure and provide with or integrate into a Lenovo Machine at your request.

The warranty is voided by removal or alteration of identification labels on the Machine or its parts.

Lenovo does not warrant uninterrupted or error-free operation of a Machine.

Any technical or other support provided for a Machine under warranty, such as assistance with "how-to" questions and those regarding Machine set-up and installation, is provided **WITHOUT WARRANTIES OF ANY KIND.**

### How to Obtain Warranty Service

Warranty service may be provided by Lenovo, IBM, your reseller if authorized to perform warranty service, or an authorized warranty service provider. Each of them is referred to as a "Service Provider."

If the Machine does not function as warranted during the warranty period, contact a Service Provider. If you do not register the Machine with Lenovo, you may be required to present proof of purchase as evidence of your entitlement to warranty service.

### **What Lenovo Will Do to Correct Problems**

When you contact a Service Provider for service, you must follow the problem determination and resolution procedures that we specify. An initial diagnosis of your problem can be made either by a technician over the telephone or electronically by access to a support website.

The type of warranty service applicable to your Machine is specified in Part 3 - Warranty Information.

You are responsible for downloading and installing designated software updates from a support web site or from other electronic media, and following the instructions that your Service Provider provides. Software updates may include basic input/output system code (called "BIOS"), utility programs, device drivers, and other software updates.

If your problem can be resolved with a Customer Replaceable Unit ("CRU") (e.g., keyboard, mouse, speaker, memory, hard disk drive), your Service Provider will ship the CRU to you for you to install.

If the Machine does not function as warranted during the warranty period and your problem cannot be resolved over the telephone or electronically, through your application of software updates, or with a CRU, your Service Provider, will either, at its discretion, 1) repair it to make it function as warranted, or 2) replace it with one that is at least functionally equivalent. If your Service Provider is unable to do either, you may return the Machine to your place of purchase and your money will be refunded.

As part of the warranty service, your Service Provider may also install selected engineering changes that apply to the Machine.

### **Exchange of a Machine or Part**

When the warranty service involves the exchange of a Machine or part, the item your Service Provider replaces becomes Lenovo's property and the replacement becomes yours. You represent that all removed items are genuine and unaltered. The replacement may not be new, but will be in good working order and at least functionally equivalent to the item replaced. The replacement assumes the warranty service status of the replaced item.

### **Your Additional Responsibilities**

Before your Service Provider exchanges a Machine or part, you agree to remove all features, parts, options, alterations, and attachments not under warranty service.

You also agree to:

1. ensure that the Machine is free of any legal obligations or restrictions that prevent its exchange;
2. obtain authorization from the owner to have your Service Provider service a Machine that you do not own; and
3. where applicable, before service is provided:
  - a. follow the service request procedures that your Service Provider provides;
  - b. backup or secure all programs, data, and funds contained in the Machine; and
  - c. provide your Service Provider with sufficient, free, and safe access to your facilities to permit Lenovo to fulfill its obligations.
4. (a) ensure all information about identified or identifiable individuals (Personal Data) is deleted from the Machine (to the extent technically possible), (b) allow your Service Provider or a supplier to process on your behalf any remaining Personal Data as your Service Provider considers necessary to fulfill its obligations under this Statement of Limited Warranty (which may include shipping the Machine for such processing to other service locations around the world), and (c) ensure that such processing complies with any laws applicable to such Personal Data.

### **Limitation of Liability**

Lenovo is responsible for loss of, or damage to, your Machine only while it is 1) in your Service Provider's possession or 2) in transit in those cases where Lenovo is responsible for the transportation charges.

Neither Lenovo nor your Service Provider are responsible for any of your confidential, proprietary or personal information contained in a Machine which you return for any reason. You should remove all such information from the Machine prior to its return.

Circumstances may arise where, because of a default on Lenovo's part or other liability, you are entitled to recover damages from Lenovo. In each such instance, regardless of the basis on which you are entitled to claim damages from Lenovo (including fundamental breach, negligence, misrepresentation, or other contract or tort claim), except for any liability that cannot be waived or limited by applicable laws, Lenovo is liable for no more than

1. damages for bodily injury (including death) and damage to real property and tangible personal property for which Lenovo is legally liable; and
2. the amount of any other actual direct damages, up to the charges for the Machine that is subject of the claim.

This limit also applies to Lenovo's suppliers, resellers and your Service Provider. It is the maximum for which Lenovo, its suppliers, resellers, and your Service Provider are collectively responsible.

**UNDER NO CIRCUMSTANCES IS LENOVO, ITS SUPPLIERS, RESELLERS OR SERVICE PROVIDERS LIABLE FOR ANY OF THE FOLLOWING EVEN IF INFORMED OF THEIR POSSIBILITY: 1) THIRD PARTY CLAIMS AGAINST YOU FOR DAMAGES (OTHER THAN THOSE UNDER THE FIRST ITEM LISTED ABOVE); 2) LOSS OF, OR DAMAGE TO, DATA; 3) SPECIAL, INCIDENTAL, OR INDIRECT DAMAGES OR FOR ANY ECONOMIC CONSEQUENTIAL DAMAGES; OR 4) LOST PROFITS, BUSINESS REVENUE, GOODWILL OR ANTICIPATED SAVINGS. SOME STATES OR JURISDICTIONS DO NOT ALLOW THE EXCLUSION OR LIMITATION OF INCIDENTAL OR CONSEQUENTIAL DAMAGES, SO THE ABOVE LIMITATION OR EXCLUSION MAY NOT APPLY TO YOU.**

### **Governing Law**

Both you and Lenovo consent to the application of the laws of the country in which you acquired the Machine to govern, interpret, and enforce all of your and Lenovo's rights, duties, and obligations arising from, or relating in any manner to, the subject matter of this Statement of Limited Warranty, without regard to conflict of law principles.

**THESE WARRANTIES GIVE YOU SPECIFIC LEGAL RIGHTS AND YOU MAY ALSO HAVE OTHER RIGHTS WHICH VARY FROM STATE TO STATE OR JURISDICTION TO JURISDICTION.**

### **Jurisdiction**

All of our rights, duties, and obligations are subject to the courts of the country in which you acquired the Machine.

---

## **Part 2 - Country-unique Terms**

### **AMERICAS**

#### **ARGENTINA**

**Jurisdiction:** *The following is added after the first sentence:*

Any litigation arising from this Statement of Limited Warranty will be settled exclusively by the Ordinary Commercial Court of the city of Buenos Aires.

## **BOLIVIA**

**Jurisdiction:** *The following is added after the first sentence:*

Any litigation arising from this Statement of Limited Warranty will be settled exclusively by the courts of the city of La Paz.

## **BRAZIL**

**Jurisdiction:** *The following is added after the first sentence:*

Any litigation arising from this Statement of Limited Warranty will be settled exclusively by the court of Rio de Janeiro, RJ.

## **CHILE**

**Jurisdiction:** *The following is added after the first sentence:*

Any litigation arising from this Statement of Limited Warranty will be settled exclusively by the Civil Courts of Justice of Santiago.

## **COLOMBIA**

**Jurisdiction:** *The following is added after the first sentence:*

Any litigation arising from this Statement of Limited Warranty will be settled exclusively by the Judges of the Republic of Colombia.

## **ECUADOR**

**Jurisdiction:** *The following is added after the first sentence:*

Any litigation arising from this Statement of Limited Warranty will be settled exclusively by the Judges of Quito.

## **MEXICO**

**Jurisdiction:** *The following is added after the first sentence:*

Any litigation arising from this Statement of Limited Warranty will be settled exclusively by the Federal Courts of Mexico City, Federal District.

## **PARAGUAY**

**Jurisdiction:** *The following is added after the first sentence:*

Any litigation arising from this Statement of Limited Warranty will be settled exclusively by the courts of the city of Asuncion.

## **PERU**

**Jurisdiction:** *The following is added after the first sentence:*

Any litigation arising from this Statement of Limited Warranty will be settled exclusively by the Judges and Tribunals of the Judicial District of Lima, Cercado.

**Limitation of Liability:** *The following is added at the end of this section:*

In accordance with Article 1328 of the Peruvian Civil Code the limitations and exclusions specified in this section will not apply to damages caused by Lenovo's willful misconduct ("dolo") or gross negligence ("culpa inexcusable").

## **URUGUAY**

**Jurisdiction:** *The following is added after the first sentence:*

Any litigation arising from this Statement of Limited Warranty will be settled exclusively by the City of Montevideo Court's Jurisdiction.

## **VENEZUELA**

**Jurisdiction:** *The following is added after the first sentence:*

Any litigation arising from this Statement of Limited Warranty will be settled exclusively by the Courts of the Metropolitan Area Of the City of Caracas.

## **NORTH AMERICA**



**How to Obtain Warranty Service:** *The following is added to this Section:*

To obtain warranty service from IBM service in Canada or the United States, call 1-800-IBM-SERV (426-7378).

#### **CANADA**

**Limitation of Liability:** *The following replaces item 1 of this section:*

1. damages for bodily injury (including death) or physical harm to real property and tangible personal property caused by Lenovo's negligence; and

**Governing Law:** *The following replaces "laws of the country in which you acquired the Machine" in the first sentence:*

laws in the Province of Ontario.

#### **UNITED STATES**

**Governing Law:** *The following replaces "laws of the country in which you acquired the Machine" in the first sentence:*

laws of the State of New York.

#### **ASIA PACIFIC**

##### **AUSTRALIA**

**What this Warranty Covers:** *The following paragraph is added to this section:*

The warranties specified in this Section are in addition to any rights you may have under the Trade Practices Act 1974 or other similar legislation and are only limited to the extent permitted by the applicable legislation.

**Limitation of Liability:** *The following is added to this section:*

Where Lenovo is in breach of a condition or warranty implied by the Trade Practices Act 1974 or other similar legislation, Lenovo's liability is limited to the repair or replacement of the goods or the supply of equivalent goods. Where that condition or warranty relates to right to sell, quiet possession or clear title, or the goods are of a kind ordinarily acquired for personal, domestic or household use or consumption, then none of the limitations in this paragraph apply.

**Governing Law:** *The following replaces "laws of the country in which you acquired the Machine" in the first sentence:*

laws of the State or Territory.

##### **CAMBODIA AND LAOS**

**Governing Law:** *The following replaces "laws of the country in which you acquired the Machine" in the first sentence:*

laws of the State of New York, United States of America.

##### **CAMBODIA, INDONESIA, AND LAOS**

**Arbitration:** *The following is added under this heading:*

Disputes arising out of or in connection with this Statement of Limited Warranty shall be finally settled by arbitration which shall be held in Singapore in accordance with the Arbitration Rules of Singapore International Arbitration Center ("SIAC Rules") then in effect. The arbitration award shall be final and binding for the parties without appeal and shall be in writing and set forth the findings of fact and the conclusions of law.

The number of arbitrators shall be three, with each side to the dispute being entitled to appoint one arbitrator. The two arbitrators appointed by the parties shall appoint a third arbitrator who shall act as chairman of the proceedings. Vacancies in the post of chairman shall be filled by the president of the SIAC. Other vacancies shall be filled by the respective nominating party. Proceedings shall continue from the stage they were at when the vacancy occurred.

If one of the parties refuses or otherwise fails to appoint an arbitrator within 30 days of the date the other party appoints its, the first appointed arbitrator shall be the sole arbitrator, provided that the arbitrator was validly and properly appointed.

All proceedings shall be conducted, including all documents presented in such proceedings, in the English language. The English language version of this Statement of Limited Warranty prevails over any other language version.

#### **HONG KONG S.A.R. OF CHINA AND MACAU S.A.R. OF CHINA**

**Governing Law:** *The following replaces "laws of the country in which you acquired the Machine" in the first sentence:*

laws of Hong Kong Special Administrative Region of China.

#### **INDIA**

**Limitation of Liability:** *The following replaces items 1 and 2 of this section:*

1. liability for bodily injury (including death) or damage to real property and tangible personal property will be limited to that caused by Lenovo's negligence; and
2. as to any other actual damage arising in any situation involving nonperformance by Lenovo pursuant to, or in any way related to the subject of this Statement of Limited Warranty, the charge paid by you for the individual Machine that is the subject of the claim.

**Arbitration:** *The following is added under this heading*

Disputes arising out of or in connection with this Statement of Limited Warranty shall be finally settled by arbitration which shall be held in Bangalore, India in accordance with the laws of India then in effect. The arbitration award shall be final and binding for the parties without appeal and shall be in writing and set forth the findings of fact and the conclusions of law.

The number of arbitrators shall be three, with each side to the dispute being entitled to appoint one arbitrator. The two arbitrators appointed by the parties shall appoint a third arbitrator who shall act as chairman of the proceedings. Vacancies in the post of chairman shall be filled by the president of the Bar Council of India. Other vacancies shall be filled by the respective nominating party. Proceedings shall continue from the stage they were at when the vacancy occurred.

If one of the parties refuses or otherwise fails to appoint an arbitrator within 30 days of the date the other party appoints its, the first appointed arbitrator shall be the sole arbitrator, provided that the arbitrator was validly and properly appointed.

All proceedings shall be conducted, including all documents presented in such proceedings, in the English language. The English language version of this Statement of Limited Warranty prevails over any other language version.

#### **JAPAN**

**Governing Law:** *The following sentence is added to this section:*

Any doubts concerning this Statement of Limited Warranty will be initially resolved between us in good faith and in accordance with the principle of mutual trust.

#### **MALAYSIA**

**Limitation of Liability:** The word "*SPECIAL*" in item 3 of the fifth paragraph is deleted.

#### **NEW ZEALAND**

**What this Warranty Covers:** *The following paragraph is added to this section:*

The warranties specified in this section are in addition to any rights you may have under the Consumer Guarantees Act 1993 or other legislation which cannot be excluded or limited. The Consumer Guarantees Act 1993 will not apply in respect of any goods which Lenovo provides, if you require the goods for the purposes of a business as defined in that Act.

**Limitation of Liability:** *The following is added to this section:*

Where Machines are not acquired for the purposes of a business as defined in the Consumer Guarantees Act 1993, the limitations in this Section are subject to the limitations in that Act.

#### **PEOPLE'S REPUBLIC OF CHINA (PRC)**

**Governing Law:** *The following replaces "laws of the country in which you acquired the Machine" in the first sentence:*

laws of the State of New York, United States of America (except when local law requires otherwise).

#### **PHILIPPINES**

**Limitation of Liability:** *Item 3 in the fifth paragraph is replaced by the following:*

**SPECIAL (INCLUDING NOMINAL AND EXEMPLARY DAMAGES), MORAL, INCIDENTAL, OR INDIRECT DAMAGES FOR ANY ECONOMIC CONSEQUENTIAL DAMAGES; OR**

**Arbitration:** The following is added: under this heading

Disputes arising out of or in connection with this Statement of Limited Warranty shall be finally settled by arbitration which shall be held in Metro Manila, Philippines in accordance with the laws of the Philippines then in effect. The arbitration award shall be final and binding for the parties without appeal and shall be in writing and set forth the findings of fact and the conclusions of law.

The number of arbitrators shall be three, with each side to the dispute being entitled to appoint one arbitrator. The two arbitrators appointed by the parties shall appoint a third arbitrator who shall act as chairman of the proceedings. Vacancies in the post of chairman shall be filled by the president of the Philippine Dispute Resolution Center, Inc.. Other vacancies shall be filled by the respective nominating party. Proceedings shall continue from the stage they were at when the vacancy occurred.

If one of the parties refuses or otherwise fails to appoint an arbitrator within 30 days of the date the other party appoints its, the first appointed arbitrator shall be the sole arbitrator, provided that the arbitrator was validly and properly appointed.

All proceedings shall be conducted, including all documents presented in such proceedings, in the English language. The English language version of this Statement of Limited Warranty prevails over any other language version.

#### **SINGAPORE**

**Limitation of Liability:** *The words "SPECIAL" and "ECONOMIC" in item 3 in the fifth paragraph are deleted.*

#### **EUROPE, MIDDLE EAST, AFRICA (EMEA)**

**THE FOLLOWING TERMS APPLY TO ALL EMEA COUNTRIES:**

The terms of this Statement of Limited Warranty apply to Machines purchased from Lenovo or a Lenovo reseller.

#### **How to Obtain Warranty Service:**

*Add the following paragraph in **Western Europe** (Andorra, Austria, Belgium, Cyprus, Czech Republic, Denmark, Estonia, Finland, France, Germany, Greece, Hungary, Iceland, Ireland, Italy, Latvia, Liechtenstein, Lithuania, Luxembourg, Malta, Monaco, Netherlands, Norway, Poland, Portugal, San Marino, Slovakia, Slovenia, Spain, Sweden, Switzerland, United Kingdom, Vatican State, and any country subsequently added to the European Union, as from the date of accession):*

The warranty for Machines acquired in Western Europe shall be valid and applicable in all Western Europe countries provided the Machines have been announced and made available in such countries.

If you purchase a Machine in one of the Western European countries, as defined above, you may obtain warranty service for that Machine in any of those countries from a Service Provider, provided the Machine has been announced and made available by Lenovo in the country in which you wish to obtain service.

If you purchased a Personal Computer Machine in Albania, Armenia, Belarus, Bosnia and Herzegovina, Bulgaria, Croatia, Czech Republic, Georgia, Hungary, Kazakhstan, Kyrgyzstan, Federal Republic of Yugoslavia, Former Yugoslav Republic of Macedonia (FYROM), Moldova, Poland, Romania, Russia, Slovak Republic, Slovenia, or Ukraine, you may obtain warranty service for that Machine in any of those countries from a Service Provider, provided the Machine has been announced and made available by Lenovo in the country in which you wish to obtain service..

If you purchase a Machine in a Middle Eastern or African country, you may obtain warranty service for that Machine from a Service Provider within the country of purchase, provided the Machine has been announced and made available by Lenovo in that country. Warranty service in Africa is available within 50 kilometers of a Service Provider. You are responsible for transportation costs for Machines located outside 50 kilometers of a Service Provider.

#### **Governing Law:**

*The phrase "the laws of the country in which you acquired the Machine" is replaced by:*

1) "the laws of Austria" in **Albania, Armenia, Azerbaijan, Belarus, Bosnia-Herzegovina, Bulgaria, Croatia, Georgia, Hungary, Kazakhstan, Kyrgyzstan, FYR Macedonia, Moldova, Poland, Romania, Russia, Slovakia, Slovenia, Tajikistan, Turkmenistan, Ukraine, Uzbekistan, and FR Yugoslavia;** 2) "the laws of France" in **Algeria, Benin, Burkina Faso, Cameroon, Cape Verde, Central African Republic, Chad, Comoros, Congo Republic, Djibouti, Democratic Republic of Congo, Equatorial Guinea, French Guiana, French Polynesia, Gabon, Gambia, Guinea, Guinea-Bissau, Ivory Coast, Lebanon, Madagascar, Mali, Mauritania, Mauritius, Mayotte, Morocco, New Caledonia, Niger, Reunion, Senegal, Seychelles, Togo, Tunisia, Vanuatu, and Wallis & Futuna;** 3) "the laws of Finland" in **Estonia, Latvia, and Lithuania;** 4) "the laws of England" in **Angola, Bahrain, Botswana, Burundi, Egypt, Eritrea, Ethiopia, Ghana, Jordan, Kenya, Kuwait, Liberia, Malawi, Malta, Mozambique, Nigeria, Oman, Pakistan, Qatar, Rwanda, Sao Tome, Saudi Arabia, Sierra Leone, Somalia, Tanzania, Uganda, United Arab Emirates, the United Kingdom, West Bank/Gaza, Yemen, Zambia, and Zimbabwe;** and 5) "the laws of South Africa" in **South Africa, Namibia, Lesotho and Swaziland.**

*Jurisdiction: The following exceptions are added to this section:*

1) **In Austria** the choice of jurisdiction for all disputes arising out of this Statement of Limited Warranty and relating thereto, including its existence, will be the competent court of law in Vienna, Austria (Inner-City); 2) **in Angola, Bahrain, Botswana, Burundi, Egypt, Eritrea, Ethiopia, Ghana, Jordan, Kenya, Kuwait, Liberia, Malawi, Malta, Mozambique, Nigeria, Oman, Pakistan, Qatar, Rwanda, Sao Tome, Saudi Arabia, Sierra Leone, Somalia, Tanzania, Uganda, United Arab Emirates, West Bank/Gaza, Yemen, Zambia, and Zimbabwe** all disputes arising out of this Statement of Limited Warranty or related to its execution, including summary proceedings, will be submitted to the exclusive jurisdiction of the English courts; 3) **in Belgium and Luxembourg**, all disputes arising out of this Statement of Limited Warranty or related to its interpretation or its execution, the law, and the courts of the capital city, of the country of your registered office and/or commercial site location only are competent; 4) **in France, Algeria, Benin, Burkina Faso, Cameroon, Cape Verde, Central African Republic, Chad, Comoros, Congo Republic, Djibouti, Democratic Republic of Congo, Equatorial Guinea, French Guiana, French Polynesia, Gabon, Gambia, Guinea, Guinea-Bissau, Ivory Coast, Lebanon, Madagascar, Mali, Mauritania, Mauritius, Mayotte, Morocco, New Caledonia, Niger, Reunion, Senegal, Seychelles, Togo, Tunisia, Vanuatu, and Wallis & Futuna** all disputes arising out of this Statement of Limited Warranty or related to its violation or execution, including summary proceedings, will be settled exclusively by the Commercial Court of Paris; 5) **in Russia**, all disputes arising out of or in relation to the interpretation, the violation, the termination, the nullity of the execution of this Statement of Limited Warranty shall be settled by Arbitration Court of Moscow; 6) **in South Africa, Namibia, Lesotho and Swaziland**, both of us agree to submit all disputes relating to this Statement of Limited Warranty to the jurisdiction of the High Court in Johannesburg; 7) **in Turkey** all disputes arising out of or in connection with this Statement of

Limited Warranty shall be resolved by the Istanbul Central (Sultanahmet) Courts and Execution Directorates of Istanbul, the Republic of Turkey; 8) in each of the following specified countries, any legal claim arising out of this Statement of Limited Warranty will be brought before, and settled exclusively by, the competent court of a) Athens for **Greece**, b) Tel Aviv-Jaffa for **Israel**, c) Milan for **Italy**, d) Lisbon for **Portugal**, and e) Madrid for **Spain**; and 9) **in the United Kingdom**, both of us agree to submit all disputes relating to this Statement of Limited Warranty to the jurisdiction of the English courts.

**Arbitration:** *The following is added under this heading:*

**In Albania, Armenia, Azerbaijan, Belarus, Bosnia-Herzegovina, Bulgaria, Croatia, Georgia, Hungary, Kazakhstan, Kyrgyzstan, FYR Macedonia, Moldova, Poland, Romania, Russia, Slovakia, Slovenia, Tajikistan, Turkmenistan, Ukraine, Uzbekistan, and FR Yugoslavia** all disputes arising out of this Statement of Limited Warranty or related to its violation, termination or nullity will be finally settled under the Rules of Arbitration and Conciliation of the International Arbitral Center of the Federal Economic Chamber in Vienna (Vienna Rules) by three arbitrators appointed in accordance with these rules. The arbitration will be held in Vienna, Austria, and the official language of the proceedings will be English. The decision of the arbitrators will be final and binding upon both parties. Therefore, pursuant to paragraph 598 (2) of the Austrian Code of Civil Procedure, the parties expressly waive the application of paragraph 595 (1) figure 7 of the Code. Lenovo may, however, institute proceedings in a competent court in the country of installation.

**In Estonia, Latvia and Lithuania** all disputes arising in connection with this Statement of Limited Warranty will be finally settled in arbitration that will be held in Helsinki, Finland in accordance with the arbitration laws of Finland then in effect. Each party will appoint one arbitrator. The arbitrators will then jointly appoint the chairman. If arbitrators cannot agree on the chairman, then the Central Chamber of Commerce in Helsinki will appoint the chairman.

## EUROPEAN UNION (EU)

### **THE FOLLOWING TERMS APPLY TO ALL EU COUNTRIES:**

The warranty for Machines acquired in EU countries is valid and applicable in all EU countries provided the Machines have been announced and made available in such countries.

**How to Obtain Warranty Service:** *The following is added to this section:*

To obtain warranty service from IBM service in EU countries, see the telephone listing in Part 3 - Warranty Information.

You may contact IBM service at the following address:

IBM Warranty & Service Quality Dept.  
PO Box 30  
Spango Valley  
Greenock  
Scotland PA16 0AH

## CONSUMERS

Consumers have legal rights under applicable national legislation governing the sale of consumer goods. Such rights are not affected by the warranties provided in this Statement of Limited Warranty.

## AUSTRIA, DENMARK, FINLAND, GREECE, ITALY, NETHERLANDS, NORWAY, PORTUGAL, SPAIN, SWEDEN AND SWITZERLAND

**Limitation of Liability:** *The following replaces the terms of this section in its entirety:*

Except as otherwise provided by mandatory law:

1. Lenovo's liability for any damages and losses that may arise as a consequence of the fulfillment of its obligations under or in connection with this Statement of Limited Warranty or due to any other cause related to this Statement of Limited Warranty is limited to the compensation of only those damages and losses proved and actually arising as an immediate and direct consequence of the non-fulfillment of such obligations (if Lenovo is at fault) or of such cause, for a maximum amount equal to the charges you paid for the Machine.



The above limitation shall not apply to damages for bodily injuries (including death) and damages to real property and tangible personal property for which Lenovo is legally liable.

2. **UNDER NO CIRCUMSTANCES IS LENOVO, ITS SUPPLIERS, RESELLERS OR SERVICE PROVIDERS LIABLE FOR ANY OF THE FOLLOWING, EVEN IF INFORMED OF THEIR POSSIBILITY: 1) LOSS OF, OR DAMAGE TO, DATA; 2) INCIDENTAL OR INDIRECT DAMAGES, OR FOR ANY ECONOMIC CONSEQUENTIAL DAMAGES; 3) LOST PROFITS, EVEN IF THEY ARISE AS AN IMMEDIATE CONSEQUENCE OF THE EVENT THAT GENERATED THE DAMAGES; OR 4) LOSS OF BUSINESS, REVENUE, GOODWILL, OR ANTICIPATED SAVINGS.**

#### **FRANCE AND BELGIUM**

**Limitation of Liability:** *The following replaces the terms of this section in its entirety:*

Except as otherwise provided by mandatory law:

1. Lenovo's liability for any damages and losses that may arise as a consequence of the fulfillment of its obligations under or in connection with this Statement of Limited Warranty is limited to the compensation of only those damages and losses proved and actually arising as an immediate and direct consequence of the non-fulfillment of such obligations (if Lenovo is at fault), for a maximum amount equal to the charges you paid for the Machine that has caused the damages.

The above limitation shall not apply to damages for bodily injuries (including death) and damages to real property and tangible personal property for which Lenovo is legally liable.

2. **UNDER NO CIRCUMSTANCES IS LENOVO, ITS SUPPLIERS, RESELLERS OR SERVICE PROVIDERS LIABLE FOR ANY OF THE FOLLOWING, EVEN IF INFORMED OF THEIR POSSIBILITY: 1) LOSS OF, OR DAMAGE TO, DATA; 2) INCIDENTAL OR INDIRECT DAMAGES, OR FOR ANY ECONOMIC CONSEQUENTIAL DAMAGES; 3) LOST PROFITS, EVEN IF THEY ARISE AS AN IMMEDIATE CONSEQUENCE OF THE EVENT THAT GENERATED THE DAMAGES; OR 4) LOSS OF BUSINESS, REVENUE, GOODWILL, OR ANTICIPATED SAVINGS.**

#### **THE FOLLOWING TERMS APPLY TO THE COUNTRY SPECIFIED:**

##### **AUSTRIA**

**The provisions of this Statement of Limited Warranty replace any applicable statutory warranties.**

**What this Warranty Covers:** *The following replaces the first sentence of the first paragraph of this section:*

The warranty for a Lenovo Machine covers the functionality of the Machine for its normal use and the Machine's conformity to its Specifications.

*The following paragraphs are added to this section:*

The limitation period for consumers in action for breach of warranty is the statutory period as a minimum. In case your Service Provider is unable to repair a Lenovo Machine, you can alternatively ask for a partial refund as far as justified by the reduced value of the unrepaired Machine or ask for a cancellation of the respective agreement for such Machine and get your money refunded.

*The second paragraph does not apply.*

**What Lenovo Will Do to Correct Problems:** *The following is added to this section:*

During the warranty period, Lenovo will reimburse you for the transportation charges for the delivery of the failing Machine to IBM Service.

**Limitation of Liability:** *The following paragraph is added to this section:*

The limitations and exclusions specified in the Statement of Limited Warranty will not apply to damages caused by Lenovo with fraud or gross negligence and for express warranty.

*The following sentence is added to the end of item 2:*

Lenovo's liability under this item is limited to the violation of essential contractual terms in cases of ordinary negligence.

## EGYPT

**Limitation of Liability:** *The following replaces item 2 in this section:*

as to any other actual direct damages, Lenovo's liability will be limited to the total amount you paid for the Machine that is the subject of the claim.

*Applicability of suppliers, resellers, and Service Providers (unchanged).*

## FRANCE

**Limitation of Liability:** *The following replaces the second sentence of the first paragraph of this section:*

In such instances, regardless of the basis on which you are entitled to claim damages from Lenovo, Lenovo is liable for no more than: (items 1 and 2 unchanged).

## GERMANY

**What this Warranty Covers:** *The following replaces the first sentence of the first paragraph of this section:*

The warranty for a Lenovo Machine covers the functionality of the Machine for its normal use and the Machine's conformity to its Specifications.

*The following paragraphs are added to this section:*

The minimum warranty period for Machines is twelve months. In case your Service Provider is unable to repair a Lenovo Machine, you can alternatively ask for a partial refund as far as justified by the reduced value of the unrepaired Machine or ask for a cancellation of the respective agreement for such Machine and get your money refunded.

*The second paragraph does not apply.*

**What Lenovo Will Do to Correct Problems:** *The following is added to this section:*

During the warranty period, transportation for delivery of the failing Machine to Lenovo or IBM service will be at Lenovo's expense.

**Limitation of Liability:** *The following paragraph is added to this section:*

The limitations and exclusions specified in the Statement of Limited Warranty will not apply to damages caused by Lenovo with fraud or gross negligence and for express warranty.

*The following sentence is added to the end of item 2:*

Lenovo's liability under this item is limited to the violation of essential contractual terms in cases of ordinary negligence.

## HUNGARY

**Limitation of Liability:** *The following is added at the end of this section:*

The limitation and exclusion specified herein shall not apply to liability for a breach of contract damaging life, physical well-being, or health that has been caused intentionally, by gross negligence, or by a criminal act.

The parties accept the limitations of liability as valid provisions and state that the Section 314.(2) of the Hungarian Civil Code applies as the acquisition price as well as other advantages arising out of the present Statement of Limited Warranty balance this limitation of liability.

## IRELAND

**What this Warranty Covers:** *The following is added to this section:*

Except as expressly provided in these terms and conditions, all statutory conditions, including all warranties implied, but without prejudice to the generality of the foregoing all warranties implied by the Sale of Goods Act 1893 or the Sale of Goods and Supply of Services Act 1980 are hereby excluded.

**Limitation of Liability:** *The following replaces the terms of section in its entirety:*

For the purposes of this section, a "Default" means any act, statement, omission, or negligence on the part of Lenovo in connection with, or in relation to, the subject matter of this Statement of Limited

Warranty in respect of which Lenovo is legally liable to you, whether in contract or tort. A number of Defaults which together result in, or contribute to, substantially the same loss or damage will be treated as one Default occurring on the date of occurrence of the last such Default.

Circumstances may arise where, because of a Default, you are entitled to recover damages from Lenovo.

This section sets out the extent of Lenovo's liability and your sole remedy.

1. Lenovo will accept unlimited liability for death or personal injury caused by the negligence of Lenovo.
2. Subject always to the **Items for Which Lenovo is Not Liable** below, Lenovo will accept unlimited liability for physical damage to your tangible property resulting from the negligence of Lenovo.
3. Except as provided in items 1 and 2 above, Lenovo's entire liability for actual damages for any one Default will not in any event exceed 125% of the amount you paid for the Machine directly relating to the Default.

#### **Items for Which Lenovo is Not Liable**

Save with respect to any liability referred to in item 1 above, under no circumstances is Lenovo, its suppliers, resellers or Service Providers liable for any of the following, even if Lenovo or they were informed of the possibility of such losses:

1. loss of, or damage to, data;
2. special, indirect, or consequential loss; or
3. loss of profits, business, revenue, goodwill, or anticipated savings.

#### **SLOVAKIA**

**Limitation of Liability:** *The following is added to the end of the last paragraph:*

The limitations apply to the extent they are not prohibited under §§ 373-386 of the Slovak Commercial Code.

#### **SOUTH AFRICA, NAMIBIA, BOTSWANA, LESOTHO AND SWAZILAND**

**Limitation of Liability:** *The following is added to this section:*

Lenovo's entire liability to you for actual damages arising in all situations involving nonperformance by Lenovo in respect of the subject matter of this Statement of Warranty will be limited to the charge paid by you for the individual Machine that is the subject of your claim from Lenovo.

#### **UNITED KINGDOM**

**Limitation of Liability:** *The following replaces the terms of this section in its entirety:*

For the purposes of this section, a "Default" means any act, statement, omission, or negligence on the part of Lenovo in connection with, or in relation to, the subject matter of this Statement of Limited Warranty in respect of which Lenovo is legally liable to you, whether in contract or tort. A number of Defaults which together result in, or contribute to, substantially the same loss or damage will be treated as one Default.

Circumstances may arise where, because of a Default, you are entitled to recover damages from Lenovo.

This section sets out the extent of Lenovo's liability and your sole remedy.

1. Lenovo will accept unlimited liability for:
  - a. death or personal injury caused by the negligence of Lenovo; and
  - b. any breach of its obligations implied by Section 12 of the Sale of Goods Act 1979 or Section 2 of the Supply of Goods and Services Act 1982, or any statutory modification or re-enactment of either such Section.
2. Lenovo will accept unlimited liability, subject always to the **Items for Which Lenovo is Not Liable** below, for physical damage to your tangible property resulting from the negligence of Lenovo.
3. Lenovo's entire liability for actual damages for any one Default will not in any event, except as provided in items 1 and 2 above, exceed 125% of the total purchase price payable or the charges for the Machine directly relating to the Default.



These limits also apply to Lenovo's suppliers, resellers and Service Providers. They state the maximum for which Lenovo and such suppliers, resellers and Service Providers are collectively responsible.

**Items for Which Lenovo is Not Liable**

Save with respect to any liability referred to in item 1 above, under no circumstances is Lenovo or any of its suppliers, resellers or Service Providers liable for any of the following, even if Lenovo or they were informed of the possibility of such losses:

1. loss of, or damage to, data;
2. special, indirect, or consequential loss; or
3. loss of profits, business, revenue, goodwill, or anticipated savings.

**Part 3 - Warranty Information**

This Part 3 provides information regarding the warranty applicable to your Machine, including the warranty period and type of warranty service Lenovo provides.

**Warranty Period**

The warranty period may vary by country or region and is specified in the table below. NOTE: "Region" means either Hong Kong or Macau Special Administrative Region of China.

A warranty period of 1 year on parts and 1 year on labor means that Lenovo provides warranty service during the first year of the warranty period.

Machine Type	Country or Region of Purchase	Warranty Period	Type of Warranty Service
M500 Projector	Worldwide	3 years	7

A warranty period of 6 months on parts and 6 months on labor means that Lenovo provides warranty service during the six-month warranty period. A warranty period of 3 months on parts and 3 months on labor means that Lenovo provides warranty service during the three-month warranty period.

Machine Type	Country or Region of Purchase	Warranty Period	Type of Warranty Service
M500 Projector lamp	China	6 months	7
M500 Projector lamp	Worldwide	3 months	7

**Types of Warranty Service**

If required, your Service Provider will provide repair or exchange service depending on the type of warranty service specified for your Machine in the above table and as described below. Scheduling of service will depend upon the time of your call and is subject to parts availability. Service levels are response time objectives and are not guaranteed. The specified level of warranty service may not be available in all worldwide locations, additional charges may apply outside your Service Provider's normal service area, contact your local Service Provider representative or your reseller for country and location specific information.

**1. Customer Replaceable Unit ("CRU") Service**

Lenovo will ship CRUs to you for you to install, Tier 1 CRUs are easy to install whereas Tier 2 CRUs require some technical skill and tools. CRU information and replacement instructions are shipped with your Machine and are available from Lenovo at any time on your request. You may request that a Service Provider install CRUs, at no additional charge, under the type of warranty service designated for your Machine. Lenovo specifies in the materials shipped with a replacement CRU

whether a defective CRU must be returned. When return is required, 1) return instructions and a container are shipped with the replacement CRU, and 2) you may be charged for the replacement CRU if Lenovo does not receive the defective CRU within 30 days of your receipt of the replacement.

**2. On-site Service**

Your Service Provider will either repair or exchange the failing Machine at your location and verify its operation. You must provide suitable working area to allow disassembly and reassembly of the Lenovo Machine. The area must be clean, well lit and suitable for the purpose. For some Machines, certain repairs may require sending the Machine to a designated service center.

**3. Courier or Depot Service \***

You will disconnect the failing Machine for collection arranged by your Service Provider. A shipping container will be provided to you for you to return your Machine to a designated service center. A courier will pick up your Machine and deliver it to the designated service center. Following its repair or exchange, the service center will arrange the return delivery of the Machine to your location. You are responsible for its installation and verification.

**4. Customer Carry-In or Mail-In Service**

You will deliver or mail as your Service Provider specifies (prepaid unless specified otherwise) the failing Machine suitably packaged to a designated location. After the Machine has been repaired or exchanged, it will be made available for your collection or, for Mail-in Service, the Machine will be returned to you at Lenovo’s expense, unless your Service Provider specifies otherwise. You are responsible for the subsequent installation and verification of the Machine.

**5. CRU and On-site Service**

This type of Warranty Service is a combination of Type 1 and Type 2 (see above).

**6. CRU and Courier or Depot Service**

This type of Warranty Service is a combination of Type 1 and Type 3 (see above).

**7. CRU and Customer Carry-In or Mail-In Service**

This type of Warranty Service is a combination of Type 1 and Type 4 (see above).

**When a 5, 6 or 7 type of warranty service is listed, your Service Provider will determine which type of warranty service is appropriate for the repair.**

\* This type of service is called ThinkPad EasyServ or EasyServ in some countries.

To obtain warranty service contact a Service Provider. In Canada or the United States, call 1-800-IBM-SERV (426-7378). In other countries, see the telephone numbers below.

**Worldwide telephone list**

Phone numbers are subject to change without notice. For the most current phone numbers, go to <http://www.lenovo.com/support> and click **Support phone list**.

Country or Region	Telephone Number
Africa	Africa: +44 (0)1475-555-055 South Africa: +27-11-3028888 and 0800110756 Central Africa: Contact your Lenovo service provider
Argentina	0800-666-0011 (Spanish)
Australia	131-426 (English)
Austria	Up and running support: 01-24592-5901 Warranty service and support: 01-211-454-610 (German)
Belgium	Up and running support: 02-210-9820 (Dutch) Up and running support: 02-210-9800 (French) Warranty service and support: 02-225-3611 (Dutch, French)

Country or Region	Telephone Number
Bolivia	0800-0189 (Spanish)
Brazil	Sao Paulo region: (11) 3889-8986 Toll free outside Sao Paulo region: 0800-7014-815 (Brazilian Portuguese)
Canada	1-800-565-3344 (English, French) In Toronto only call: 416-383-3344
Chile	800-224-488 (Spanish)
China	800-810-1818 (Mandarin)
China (Hong Kong S.A.R.)	Home PC: 852-2825-7799 Commercial PC: 852-8205-0333 ThinkPad and WorkPad: 852-2825-6580 (Cantonese, English, Putonghua)
Colombia	1-800-912-3021 (Spanish)
Costa Rica	284-3911 (Spanish)
Croatia	0800-0426
Cyprus	+357-22-841100
Czech Republic	+420-2-7213-1316
Denmark	Up and running support: 4520-8200 Warranty service and support: 7010-5150 (Danish)
Dominican Republic	566-4755 566-5161 ext. 8201 Toll Free within the Dominican Republic: 1-200-1929 (Spanish)
Ecuador	1-800-426911 (Spanish)
El Salvador	250-5696 (Spanish)
Estonia	+386-61-1796-699
Finland	Up and running support: 09-459-6960 Warranty service and support: +358-800-1-4260 (Finnish)
France	Up and running support: 0238-557-450 Warranty service and support (hardware): 0810-631-213 Warranty service and support (software): 0810-631-020 (French)
Germany	Up and running support: 07032-15-49201 Warranty service and support: 01805-25-35-58 (German)
Greece	+30-210-680-1700
Guatemala	335-8490 (Spanish)
Honduras	Tegucigalpa & San Pedro Sula: 232-4222 San Pedro Sula: 552-2234 (Spanish)
Hungary	+36-1-382-5720
India	1600-44-6666 Alternate Toll Free: +91-80-2678-8940 (English)

Country or Region	Telephone Number
Indonesia	800-140-3555 +62-21-251-2955 (English, Bahasa Indonesian)
Ireland	Up and running support: 01-815-9202 Warranty service and support: 01-881-1444 (English)
Israel	+972-3-531-3900 (Hebrew)  +972-3-531-3900 (English)  8:30 a.m. - 5:00 p.m. Sunday - Thursday (Local time)
Italy	Up and running support: 02-7031-6101 Warranty service and support: +39-800-820094 (Italian)
Japan	Desktop: Toll free: 0120-887-870 For International: +81-46-266-4724  ThinkPad: Toll free: 0120-887-874 For International: +81-46-266-4724  Both of the above numbers will be answered with a Japanese language voice prompt. For telephone support in English, please wait for the Japanese voice prompt to end, and an operator will answer. Please ask for "English support please," and your call will be transferred to an English speaking operator.  PC Software: 0120-558-695 Overseas calls: +81-44-200-8666 (Japanese)
Korea	1588-5801 (Korean)
Latvia	+386-61-1796-699
Lithuania	+386-61-1796-699
Luxembourg	+352-298-977-5063 (French)
Malaysia	1800-88-8558 (English, Bahasa Melayu)
Malta	+356-23-4175
Mexico	001-866-434-2080 (Spanish)
Middle East	+44 (0)1475-555-055
Netherlands	+31-20-514-5770 (Dutch)
New Zealand	0800-446-149 (English)
Nicaragua	255-6658 (Spanish)
Norway	Up and running support: 6681-1100 Warranty service and support: 8152-1550 (Norwegian)
Panama	206-6047 (Spanish)
Peru	0-800-50-866 (Spanish)
Philippines	1800-1888-1426 +63-2-995-8420 (English, Philipino)

Country or Region	Telephone Number
Poland	+48-22-878-6999
Portugal	+351-21-892-7147 (Portuguese)
Romania	+4-021-224-4015
Russian Federation	+7-095-940-2000 (Russian)
Singapore	1800-3172-888 (English, Bahasa, Melayu)
Slovakia	+421-2-4954-1217
Slovenia	+386-1-4796-699
Spain	91-714-7983 91-397-6503 (Spanish)
Sri Lanka	+94-11-2448-442 (English)
Sweden	Up and running support: 08-477-4420 Warranty service and support: 077-117-1040 (Swedish)
Switzerland	Up and running support: 058-333-0900 Warranty service and support: 0800-55-54-54 (German, French, Italian)
Taiwan	886-2-8723-9799 (Mandarin)
Thailand	1-800-299-229 (Thai)
Turkey	00800-4463-2041 (Turkish)
United Kingdom	Up and running support: 01475-555-055 Warranty service and support (hardware): 08705-500-900 Warranty service and support (software): 08457-151-516 (English)
United States	1-800-426-7378 (English)
Uruguay	000-411-005-6649 (Spanish)
Venezuela	0-800-100-2011 (Spanish)
Vietnam	For northern area and Hanoi: 84-4-8436675 For southern area and Ho Chi Minh City: 84-8-829-5160 (English, Vietnamese)

---

## Guarantee supplement for Mexico

This supplement is considered part of Lenovo's Statement of Limited Warranty and shall be effective solely and exclusively for products distributed and commercialized within Territory of the Mexican United States. In the event of a conflict, the terms of this supplement shall apply.

All software programs pre-loaded in the equipment shall only have a thirty- (30) day guarantee for installation defects from the date of purchase. Lenovo is not responsible for the information in such software programs and/or any additional software programs installed by you or installed after purchase of the product.

Services not chargeable to the guarantee shall be charged to the final user, prior an authorization.

In the event that warranty repair is required please call the Customer Support Center at 001-866-434-2080, where you will be directed to the nearest Authorized Service Center. Should no Authorized Service

Center exist in your city, location or within 70 kilometers of your city or location, the guarantee includes any reasonable delivery charges related to the transportation of the product to our nearest Authorized Service Center. Please call the nearest Authorized Service Center to obtain the necessary approvals or information concerning the shipment of the product and the shipment address.

To obtain a list of Authorized Service Centers, please visit:

<http://www.lenovo.com/mx/es/servicios>

**Manufactured by:**

**SCI Systems de México, S.A. de C.V.**  
**Av. De la Solidaridad Iberoamericana No. 7020**  
**Col. Club de Golf Atlas**  
**El Salto, Jalisco, México**  
**C.P. 45680,**  
**Tel. 01-800-3676900**

**Marketing by:**

**Lenovo de México, Comercialización y**  
**Servicios, S. A. de C. V.**  
**Alfonso Nápoles Gándara No 3111**  
**Parque Corporativo de Peña Blanca**  
**Delegación Álvaro Obregón**  
**México, D.F., México**  
**C.P. 01210,**  
**Tel. 01-800-00-325-00**

---

## Appendix F. Notices

Lenovo may not offer the products, services, or features discussed in this document in all countries. Consult your local Lenovo representative for information on the products and services currently available in your area. Any reference to a Lenovo product, program, or service is not intended to state or imply that only that Lenovo product, program, or service may be used. Any functionally equivalent product, program, or service that does not infringe any Lenovo intellectual property right may be used instead. However, it is the user's responsibility to evaluate and verify the operation of any other product, program, or service.

Lenovo may have patents or pending patent applications covering subject matter described in this document. The furnishing of this document does not give you any license to these patents. You can send license inquiries, in writing, to:

*Lenovo (United States), Inc.  
500 Park Offices Drive, Hwy. 54  
Research Triangle Park, NC 27709  
U.S.A.  
Attention: Lenovo Director of Licensing*

LENOVO GROUP LTD. PROVIDES THIS PUBLICATION "AS IS" WITHOUT WARRANTY OF ANY KIND, EITHER EXPRESS OR IMPLIED, INCLUDING, BUT NOT LIMITED TO, THE IMPLIED WARRANTIES OF NON-INFRINGEMENT, MERCHANTABILITY OR FITNESS FOR A PARTICULAR PURPOSE. Some jurisdictions do not allow disclaimer of express or implied warranties in certain transactions, therefore, this statement may not apply to you.

This information could include technical inaccuracies or typographical errors. Changes are periodically made to the information herein; these changes will be incorporated in new editions of the publication. Lenovo may make improvements and/or changes in the product(s) and/or the program(s) described in this publication at any time without notice.

The products described in this document are not intended for use in implantation or other life support applications where malfunction may result in injury or death to persons. The information contained in this document does not affect or change Lenovo product specifications or warranties. Nothing in this document shall operate as an express or implied license or indemnity under the intellectual property rights of Lenovo or third parties. All information contained in this document was obtained in specific environments and is presented as an illustration. The result obtained in other operating environments may vary.

Lenovo may use or distribute any of the information you supply in any way it believes appropriate without incurring any obligation to you.

Any references in this publication to non-Lenovo Web sites are provided for convenience only and do not in any manner serve as an endorsement of those Web sites. The materials at those Web sites are not part of the materials for this Lenovo product, and use of those Web sites is at your own risk.

Any performance data contained herein was determined in a controlled environment. Therefore, the result obtained in other operating environments may vary significantly. Some measurements may have been made on development-level systems and there is no guarantee that these measurements will be the same on generally available systems. Furthermore, some measurements may have been estimated through extrapolation. Actual results may vary. Users of this document should verify the applicable data for their specific environment.

---

## Trademarks

The following terms are trademarks of Lenovo in the United States, other countries, or both:

Lenovo  
ThinkPad

IBM is a trademark of International Business Machines Corporation in the United States, other countries, or both, and is used under license.

Microsoft and Windows are trademarks of Microsoft Corporation in the United States, other countries, or both.

Other company, product, or service names may be trademarks or service marks of others.



---

## Appendix G. Electronic emission notices

The following information refers to the M500 Projector.

---

### Federal Communications Commission (FCC) Declaration of Conformity

This equipment has been tested and found to comply with the limits for a Class B digital device, pursuant to Part 15 of the FCC Rules. These limits are designed to provide reasonable protection against harmful interference in a residential installation. This equipment generates, uses, and can radiate radio frequency energy and, if not installed and used in accordance with the instructions, may cause harmful interference to radio communications. However, there is no guarantee that interference will not occur in a particular installation. If this equipment does cause harmful interference to radio or television reception, which can be determined by turning the equipment off and on, the user is encouraged to try to correct the interference by one or more of the following measures:

- Reorient or relocate the receiving antenna.
- Increase the separation between the equipment and receiver.
- Connect the equipment into an outlet on a circuit different from that to which the receiver is connected.
- Consult an authorized dealer or service representative for help.

Lenovo is not responsible for any radio or television interference caused by using other than recommended cables or connectors or by unauthorized changes or modifications to this equipment. Unauthorized changes or modifications could void the user's authority to operate the equipment.

This device complies with Part 15 of the FCC Rules. Operation is subject to the following two conditions: (1) this device may not cause harmful interference, and (2) this device must accept any interference received, including interference that may cause undesired operation.

Responsible party:

Lenovo (United States) Incorporated  
One Manhattanville Road  
Purchase, New York 10577  
Telephone: (919) 254-0532



Tested To Comply  
With FCC Standards

FOR HOME OR OFFICE USE

#### Industry Canada Class B emission compliance statement

This Class B digital apparatus complies with Canadian ICES-003.

#### Avis de conformité à la réglementation d'Industrie Canada

Cet appareil numérique de la classe B est conforme à la norme NMB-003 du Canada.

#### EU-EMC Directive (89/336/EG) EN 55022 class B Statement of Compliance

#### Deutschsprachiger EU Hinweis:

**Hinweis für Geräte der Klasse B EU-Richtlinie zur Elektromagnetischen Verträglichkeit** Dieses Produkt entspricht den Schutzanforderungen der EU-Richtlinie 89/336/EWG zur Angleichung der Rechtsvorschriften über die elektromagnetische Verträglichkeit in den EU-Mitgliedsstaaten.

und hält die Grenzwerte der EN 55022 Klasse B ein.

Um dieses sicherzustellen, sind die Geräte wie in den Handbüchern beschrieben zu installieren und zu betreiben. Des Weiteren dürfen auch nur von der Lenovo empfohlene Kabel angeschlossen werden. Lenovo übernimmt keine Verantwortung für die Einhaltung der Schutzanforderungen, wenn das Produkt ohne Zustimmung der Lenovo verändert bzw. wenn Erweiterungskomponenten von Fremdherstellern ohne Empfehlung der Lenovo gesteckt/eingebaut werden.

**Deutschland: Einhaltung des Gesetzes über die elektromagnetische Verträglichkeit von Geräten** Dieses Produkt entspricht dem "Gesetz über die elektromagnetische Verträglichkeit von Geräten (EMVG)". Dies ist die Umsetzung der EU-Richtlinie 89/336/EWG in der Bundesrepublik Deutschland.

**Zulassungsbescheinigung laut dem Deutschen Gesetz über die elektromagnetische Verträglichkeit von Geräten (EMVG) vom 18. September 1998 (bzw. der EMC EG Richtlinie 89/336) für Geräte der Klasse B** Dieses Gerät ist berechtigt, in Übereinstimmung mit dem Deutschen EMVG das EG-Konformitätszeichen - CE - zu führen.

Verantwortlich für die Konformitätserklärung nach Paragraf 5 des EMVG ist die Lenovo (Deutschland) GmbH, Pascalstr. 100, D-70569 Stuttgart. Informationen in Hinsicht EMVG Paragraf 4 Abs. (1) 4:

**Das Gerät erfüllt die Schutzanforderungen nach EN 55024 und EN 55022 Klasse B.)**

#### **European Union - Compliance to the Electromagnetic Compatibility Directive**

This product is in conformity with the protection requirements of EU Council Directive 89/336/ECC on the approximation of the laws of the Member States relating to electromagnetic compatibility. Lenovo cannot accept responsibility for any failure to satisfy the protection requirements resulting from a non-recommended modification of the product, including the fitting of option cards from other manufacturers.

This product has been tested and found to comply with the limits for Class B Information Technology Equipment according to European Standard EN 55022. The limits for Class B equipment were derived for typical residential environments to provide reasonable protection against interference with licensed communication devices.

#### **Avis de conformité à la directive de l'Union Européenne**

Le présent produit satisfait aux exigences de protection énoncées dans la directive 89/336/CEE du Conseil concernant le rapprochement des législations des Etats membres relatives à la compatibilité électromagnétique. Lenovo décline toute responsabilité en cas de non-respect de cette directive résultant d'une modification non recommandée du produit, y compris l'ajout de cartes en option non Lenovo.

Ce produit respecte les limites des caractéristiques d'immunité des appareils de traitement de l'information définies par la classe B de la norme européenne EN 55022 (CISPR 22). La conformité aux spécifications de la classe B offre une garantie acceptable contre les perturbations avec les appareils de communication agréés, dans les zones résidentielles.

#### **Unión Europea - Normativa EMC**

Este producto satisface los requisitos de protección del Consejo de la UE, Directiva 89/336/CEE en lo que a la legislación de los Estados Miembros sobre compatibilidad electromagnética se refiere.

Lenovo no puede aceptar responsabilidad alguna si este producto deja de satisfacer dichos requisitos de protección como resultado de una modificación no recomendada del producto, incluyendo el ajuste de tarjetas de opción que no sean Lenovo.

Este producto ha sido probado y satisface los límites para Equipos Informáticos Clase B de conformidad con el Estándar Europeo EN 55022. Los límites para los equipos de Clase B se han establecido para entornos residenciales típicos a fin de proporcionar una protección razonable contra las interferencias con dispositivos de comunicación licenciados.

#### **Unione Europea - Directiva EMC (Conformidad electromagnética)**

Questo prodotto è conforme alle normative di protezione ai sensi della Direttiva del Consiglio dell'Unione Europea 89/336/CEE sull'armonizzazione legislativa degli stati membri in materia di compatibilità elettromagnetica.

Lenovo non accetta responsabilità alcuna per la mancata conformità alle normative di protezione dovuta a modifiche non consigliate al prodotto, compresa l'installazione di schede e componenti di marca diversa da Lenovo.

Le prove effettuate sul presente prodotto hanno accertato che esso rientra nei limiti stabiliti per le apparecchiature di informatica Classe B ai sensi della Norma Europea EN 55022. I limiti delle apparecchiature della Classe B sono stati stabiliti al fine di fornire ragionevole protezione da interferenze mediante dispositivi di comunicazione in concessione in ambienti residenziali tipici.

#### **Korea Class B Compliance**

이 기기는 가정용으로 전자파 적합등록을 한 기기로서  
주거지역에서는 물론 모든 지역에서 사용할 수 있습니다.

#### **Japan VCCI Class B Compliance**

この装置は、情報処理装置等電波障害自主規制協議会（VCCI）の基準に基づくクラスB情報技術装置です。この装置は、家庭環境で使用することを目的としていますが、この装置がラジオやテレビジョン受信機に近接して使用されると、受信障害を引き起こすことがあります。  
取扱説明書に従って正しい取り扱いをして下さい。

**Japanese statement of compliance for products less than or equal to 20 A per phase**

**高調波ガイドライン適合品**





**lenovo**

Part Number: 40Y7881

Printed in USA

(1P) P/N: 40Y7881

