

boomchair[®]

experience the ultimate level
of gaming and music

BLAST

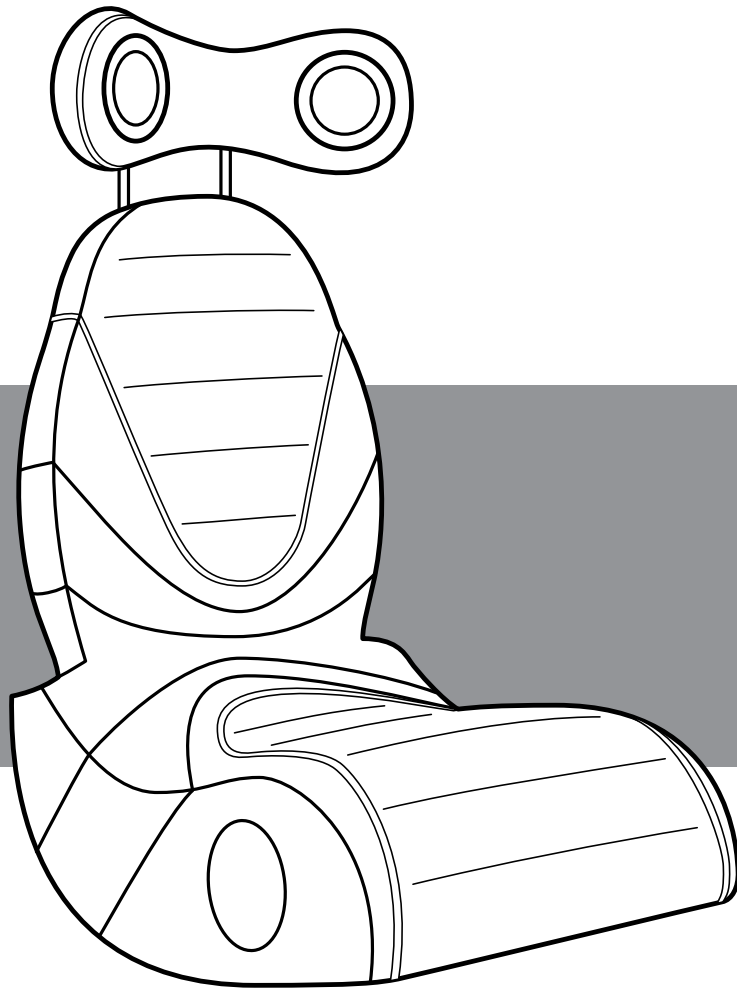

boomchair®

Congratulations!

You are now the proud owner of a BOOMCHAIR®. Prepare to experience your entertainment on a whole new level. BOOMCHAIR® allows you to HEAR the sound and FEEL the excitement. You'll experience every crash, bang, and boom while enjoying your favorite game, music, or movie. BOOMCHAIR® is also a great game seat built to endure the rigors of today's gaming environment. Take a moment to review your owner's manual before connecting your BOOMCHAIR®. Assembly and operation of the BOOMCHAIR® is simple.

If you need further assistance visit us at www.BoomChair.com or www.LumiSource.com

BOOMCHAIR®, a LumiSource® product.
LumiSource, Inc.
2950 Old Higgins Road, Elk Grove Village, IL 60007

PATENTS PENDING

CAUTIONS

READ BEFORE USE

- DO NOT wash or soak with water. If BOOMCHAIR® gets wet, disconnect power immediately and do not use until completely dry.
- Turn power off and unplug BOOMCHAIR® when not in use.
- Children under 5 years old should not use this product without parental supervision.
- For INDOOR use only/ DO NOT expose to direct sunlight, moisture, or extreme temperatures.
- DO NOT use on hardwood flooring, it may cause scratching.
- DO NOT use on slippery or uneven flooring.
- Excessive exposure to audio equipment at high volume may lead to hearing loss.
- DO NOT OPEN

Caution: To reduce the risk of electric shock and fire, do not open the BOOMCHAIR®. There are no user serviceable parts inside. Refer to your warranty for service information.



Internal

FCC part 15.21:

Warning: Changes or modifications to this unit not expressly approved by the party responsible for compliance could void the user's authority to operate the equipment.

FCC WARNING

This device complies with Part 15 of the FCC rules.

Operation is subject to the following two conditions:

- (1) This device may not cause harmful interference.
- (2) This device must accept any interference received, including interference that may cause undesired operation.

SET-UP GUIDE

The BOOMCHAIR® comes with the following:

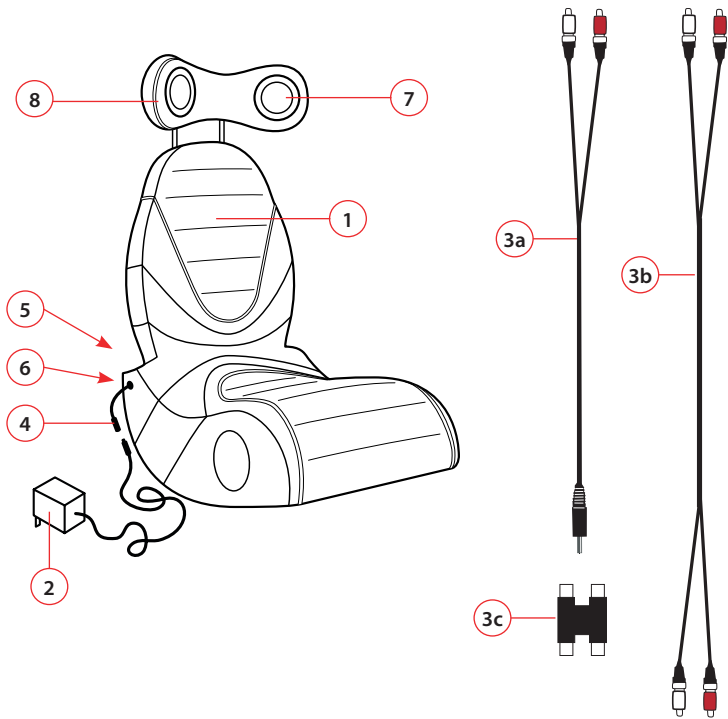

PARTS LIST:

- 1) BOOMCHAIR® VIBRATION ZONE
- 2) 12V POWER SUPPLY
- 3a) RCA TO MINI AUDIO CORD
(headphone jack to audio left & right channel connectors)
- 3b) RCA CORD (audio left & right channel connectors)
- 3c) RCA AUDIO COUPLER
- 4) POWER RECEPTACLE
- 5) HOOK & LOOP FASTENER
- 6) ADJUSTABLE RECLINE STOPPERS
- 7) ADJUSTABLE HEADREST
- 8) SPEAKERS

SYSTEM SPECS:

Dimensions: 24 in. L x 18 in. W x 36 in. H
61 cm. L x 46 cm. W x 92 cm. H

2 x 3 in. (7.5 cm.) coaxial mid-high speakers @ 3W 4 Ohms
4 in. (10 cm) sub-woofer speakers @ 15W 4 Ohms
Vibration Motors

DASHBOARD CONTROL PANEL

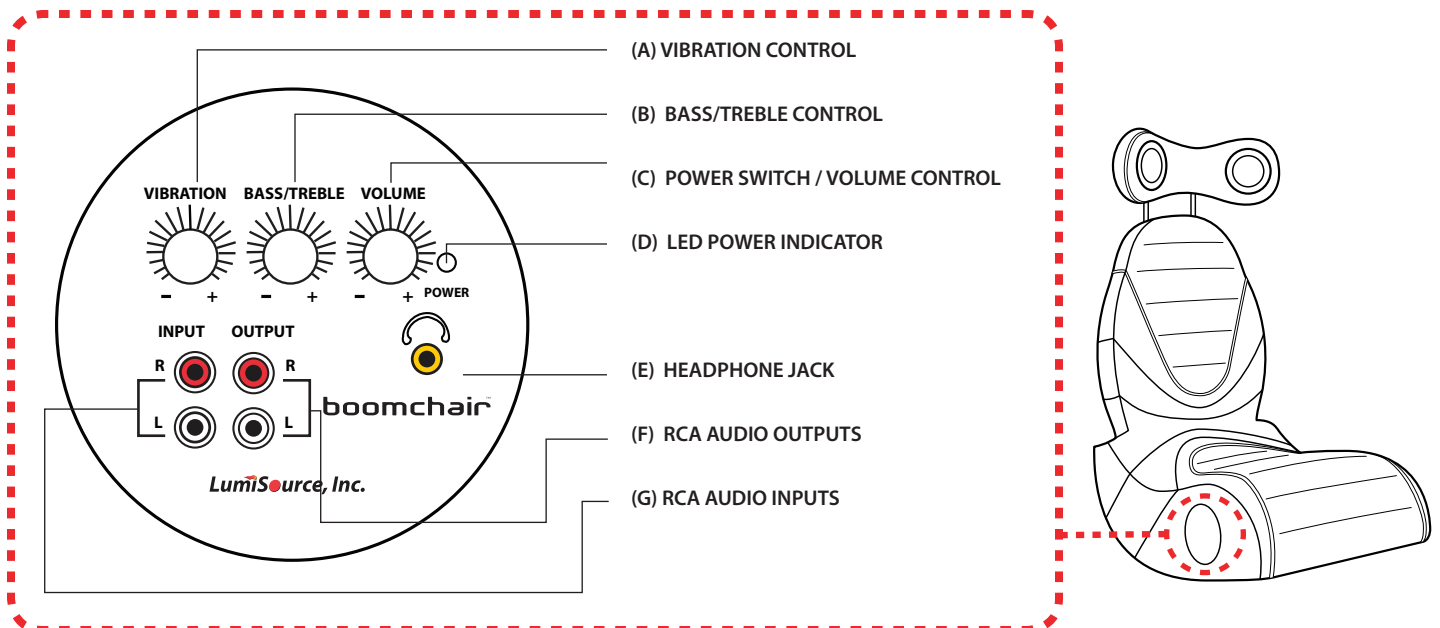

ASSEMBLY INSTRUCTIONS

Step 1: Secure the seat back using attached hook & loop fasteners.

Step 2: Connect audio cords from backrest and headrest.

Step 3: Connect plugs from base and backrest.

Step 4: Insert power receptacle (4) into adapter (2).

Step 5: Plug adapter (2) into outlet.*

Step 6: Turn Boomchair® on by turning Power knob (C) clockwise.

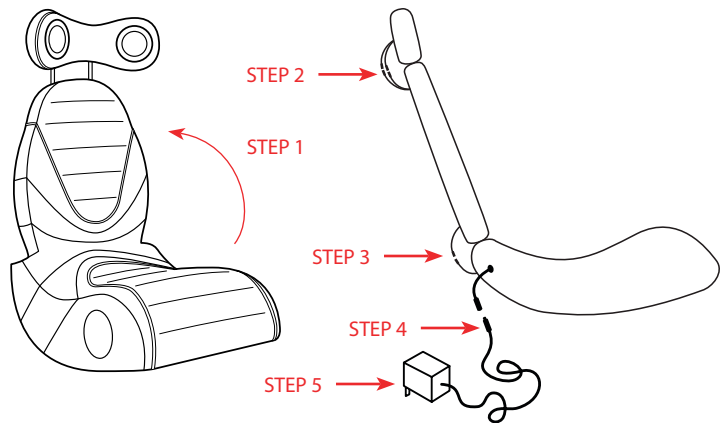

***CAUTION: Use only provided adaptor! Different voltage may cause permanent damage.**

CONNECTING TO GAME CONSOLES

Note: Most game consoles are supplied with a custom connector with yellow video out and RCA red/white audio out.

Step 1: Using the console's custom RCA cord, plug yellow composite video cable from game console into video input of TV. (Fig. 1)

Step 2: Plug Red/White RCA cord from game console into RCA INPUT (G) of BoomChair®. (Fig. 2)

Note: It may be necessary to extend your BoomChair® further away from your TV or console. Here's how. (Fig.3)

Step 1: Connect Audio Coupler (3c) to Red/White RCA cord from game console.

Step 2: Connect one end of RCA cord (3b) into other end of Audio Coupler (3c).

Step 3: Connect other end of RCA cord (3b) into RCA INPUT (G) of BoomChair®.

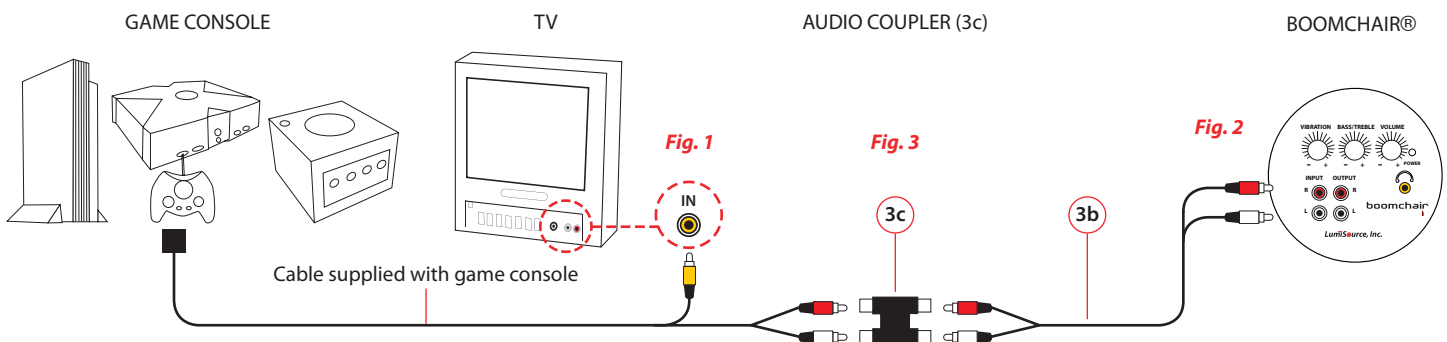

CONNECTING TO PORTABLE AUDIO / VIDEO DEVICES

Step 1: Connect the Red/White ends of RCA cord (3a) into RCA INPUT (G) of BoomChair®.

Step 2: Plug the single end of the RCA cord (3a) into the headphone jack of your device.

Step 3: Turn Boomchair® on by turning Power knob (C) clockwise.

Step 4: Turn portable device on and make sure the volume is turned up.

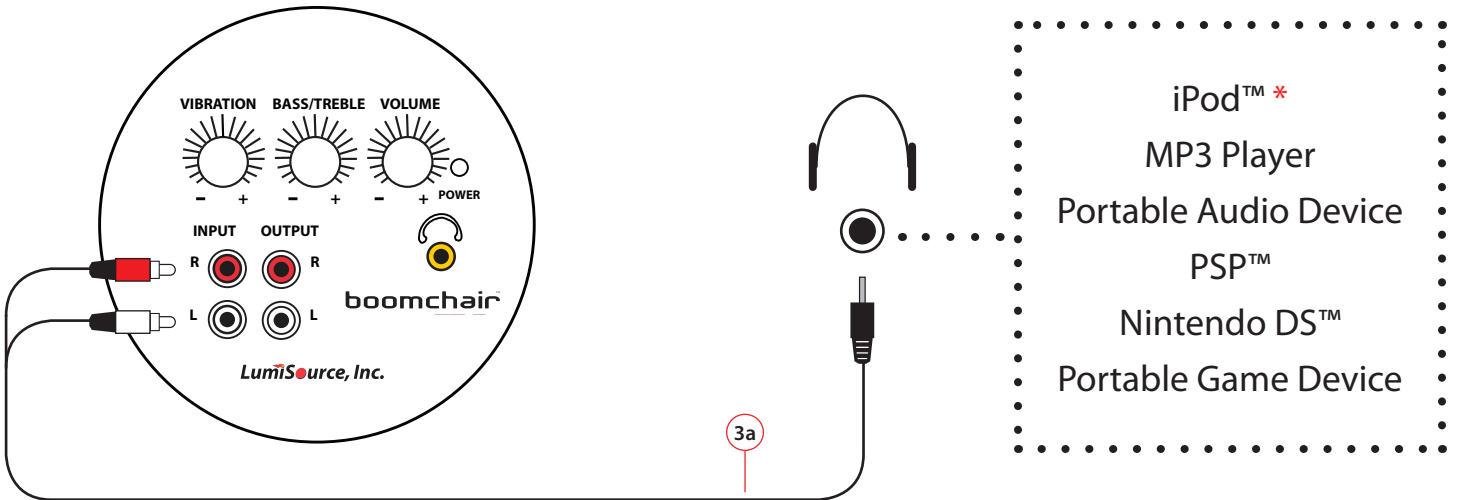

** Note: Some Apple™ devices such as iPhone™ require special 1/8in. (3.5mm) TTY adaptor (sold separately).*

CONNECTING DIRECTLY TO TV / AUDIO / VIDEO DEVICES

Note: This is an easy connection if you already have your tv hooked up to a DVD or game console or are using an HDMI cable. If your TV does not have AUDIO OUTS, you will have to use one of the alternate connections in this manual.

Step 1: Connect the Red/White ends of RCA cord (3b) into RCA INPUT (G) of BoomChair®.

Step 2: Connect the other ends of RCA cord (3b) into AUDIO OUTPUT of Audio/Video device.

Step 3: Turn Boomchair® on by turning Power knob (C) clockwise.

Step 4: Turn Audio/Video device on.

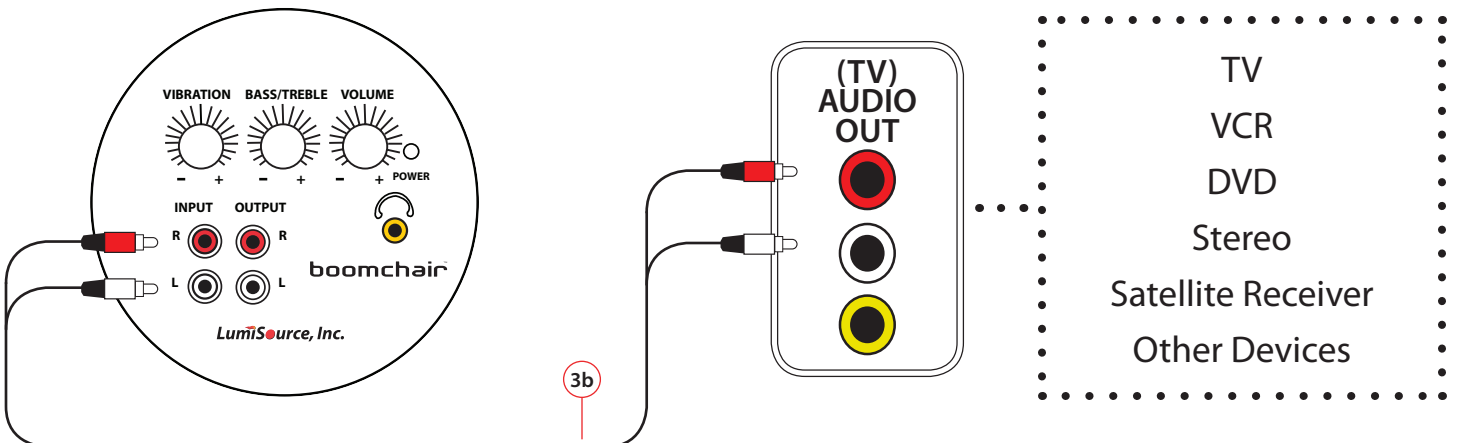

DAISY CHAINING CHAIRS TOGETHER

DIRECT CONNECTION

Step 1: Connect BoomChair® to any media device as described on pages 4 or 5. This is the first chair.

Step 2: Connect one end of RCA cord (3b) into RCA OUTPUT (F) of first BoomChair®.

Step 3: Connect other end of RCA cord (3b) into RCA INPUT (G) of second BoomChair®.

Step 4: Turn all Boomchairs® on by turning Power knob (C) clockwise.

Repeat steps 2 and 3 from second chair to connect more BoomChairs®.

Up to 4 chairs can be connected.

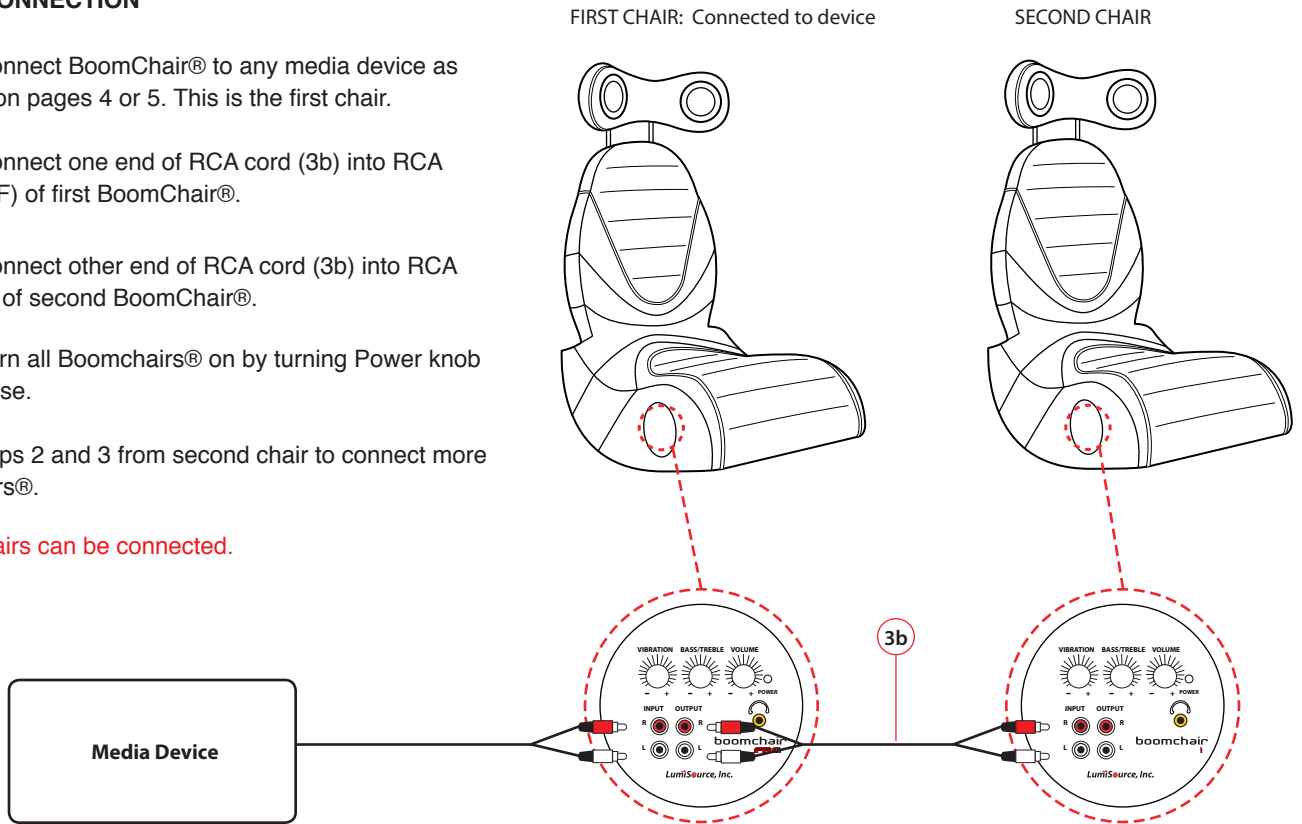

TROUBLESHOOTING BOOMCHAIR®

Q: Why isn't there sound coming from any of my speakers?

A: Ensure your BoomChair® is connected as described in the Assembly Instructions. Check that the power to the unit is on and the volume is turned up. Make sure your audio device is not set to "MUTE" and volume is turned up.

Q: Why isn't there sound coming from one of my speakers?

A: Ensure the audio cord to the BoomChair® is securely connected as described in the Connecting sections. Make sure that both the left and right channel audio inputs and outputs are securely connected to the BoomChair® and audio device. Make sure your audio device is not set to "MUTE" and volume is turned up.

Q: Why don't I feel any vibration?

A: Make sure the vibration control is switched on. The vibration is sensitive to volume and bass because it interacts with the music or game. Adjust the sensitivity of the vibration or volume according to your desired settings. Make sure your audio device is not set to "MUTE" and volume is turned up.

Q: Where can I get more information?

A: Visit us at www.BoomChair.com or www.LumiSource.com

Contact information: LumiSource, Inc. 2950 Old Higgins Road, Elk Grove Village, IL 60007

E-mail: customerservice@lumisource.com

MAINTENANCE AND REPAIR

If a problem occurs while using this product, please contact us. DO NOT open unit or attempt to repair on your own. It may result in serious injury from electric shock and void your product warranty.

CLEANING/CARE INSTRUCTIONS

Fabric: Use a clean cloth to dab lightly with soap and water. DO NOT rub.
DO NOT immerse in water. DO NOT use detergent.

NOTE: PLEASE DO NOT USE ON HARDWOOD FLOORS, IT MAY CAUSE SCRATCHING.

LUMISOURCE, INC. LIMITED WARRANTY

LIMITED WARRANTY: LumiSource, Inc. ("LumiSource") warrants this product against defects in materials and workmanship for a period of ninety (90) days from the date of original consumer purchase. If a covered warranty claim is timely made, LumiSource® will, at its sole discretion: (a) repair the product, using new and/or refurbished replacement parts or (b) replace the product with an identical (or comparable) product, without charge to you other than the initial shipping cost to return the product. LumiSource® will only pay return shipping charges for destinations within the 48 contiguous U.S.A., if the returned product is covered by the limited warranty.

WHAT THIS WARRANTY DOES NOT COVER: This warranty does not cover defects resulting from accidents, alterations, unauthorized repair, failure to follow instructions, misuse, commercial use, fire, flood, or acts of God.

WHAT WE ASK YOU TO DO: If there is a covered defect, please write or email us within 90 days of the date of purchase at the address noted on page 8 to obtain instructions and authorization to return the product to LumiSource®. You will need to pack the product securely in packaging providing at least the degree of protection of the original carton and packing materials and ship it to us at your expense. You will also need to include with the product (a) a copy of your original proof of purchase (retail receipt) showing the date of purchase and (b) a detailed explanation of the problem(s) requiring service.

TO THE EXTENT PERMITTED BY LAW, THIS LIMITED WARRANTY AND THE REMEDIES SET FORTH ABOVE ARE EXCLUSIVE AND IN LIEU OF ALL OTHER WARRANTIES, REMEDIES AND CONDITIONS, ORAL OR WRITTEN, EXPRESS OR IMPLIED. TO THE EXTENT PERMITTED BY LAW, LUMISOURCE® HEREBY DISCLAIMS ANY IMPLIED WARRANTIES, INCLUDING WITHOUT LIMITATION, WARRANTIES OF MERCHANTABILITY AND FITNESS FOR A PARTICULAR PURPOSE. TO THE EXTENT APPLICABLE STATE LAW EXCLUDES SUCH DISCLAIMERS, THEN TO THE EXTENT ALLOWED BY LAW, THE TIME FOR ANY CLAIMS FOR SUCH IMPLIED WARRANTIES SHALL EXPIRE 90 DAYS FROM THE DATE OF ORIGINAL CONSUMER PURCHASE. TO THE EXTENT PERMITTED BY LAW, LUMISOURCE® IS NOT RESPONSIBLE FOR DIRECT, SPECIAL, INCIDENTAL OR CONSEQUENTIAL DAMAGES, INCLUDING BUT NOT LIMITED TO LOSS OF TIME, INCONVENIENCE, LOSS OF USE OF YOUR PRODUCT, OR PERSONAL INJURY OR PROPERTY DAMAGE, CAUSED BY YOUR PRODUCT OR ITS FAILURE TO WORK.

This limited warranty gives you specific legal rights. Some states do not allow the exclusion or limitation of incidental or consequential damages, and applicable law may not permit the exclusion of certain implied warranties. You may also have other rights, which vary, from state to state.

LumiSource, Inc.

2950 Old Higgins Road, Elk Grove Village, IL 60007

E-mail: customerservice@lumisource.com

Phone: 1-888-461-5864 (toll free)

Phone: 1-847-699-8988 (international)

www.BoomChair.com • www.LumiSource.com

© 2009 LumiSource, Inc. All rights reserved. BoomChair® BLAST, the BoomChair® BLAST logo, and the Boom logo are trademarks of LumiSource Inc. Other trademarks are properties of their respective owners. The design of this product is a trade dress of LumiSource, Inc. Patents pending. Actual contents may differ slightly from those pictured. Made in China. Distributed by LumiSource Inc., 2950 Old Higgins Road, Elk Grove Village, IL 60007. www.lumisource.com.

This product is not manufactured or distributed by Microsoft® the owner of the trademark Xbox™. This product is not manufactured or distributed by Nintendo® the owner of the trademark GameCube™ and DS™. This product is not manufactured or distributed by Sony® the owner of the trademark Playstation™ PS3™, PS2™, and PSP™. iPod™ is a registered trademark of Apple Computer, Inc. All Rights Reserved.