

# **Fun Karts**

## **MODEL: 32001 SERIES OWNERS MANUAL**

### **WARNING:**

Read Tecumseh Engine Owner's Manual and Important Rules for Safe Operation before Operating Vehicle

### **WARNING:**

**YOU MUST ADD OIL TO THE ENGINE PRIOR TO USE!!!**  
***20 oz. or 1 ¼ Pints (.6 Liters) OF SAE 30 MOTOR OIL***

This vehicle is sold for off-road use only. Before operating this vehicle, read all the instructions for safe assembly and operation as well as the instructions governing the engine and other portions of the vehicle. Pay close attention to all caution and warning labels on the Fun-Kart.

**For Replacements Parts Call:**  
**1-888-389-5522 (U.S.)    1-888-707-1880 (Canada)**

05/08/02  
01465  
Rev. D



## Read These Important Rules For Safe Operation

***NOTE:*** *All the items (1-33) below should be read and understood by the Operator and Parent. Failure to follow these instructions could endanger personal safety of the operator.*

1. This vehicle is not licensable. **IT IS NOT TO BE OPERATED ON ANY PUBLIC ROAD, STREET, SIDEWALK or ALLEY.** To do so would be a violation of local law. This vehicle may be operated only on private property and upon areas approved by local law.
2. This vehicle should **NEVER** be operated indoors. The exhaust from the engine contains carbon monoxide, which is tasteless, odorless, and poisonous gas.
3. This Fun-Kart is not intended nor designed for racing.
4. **The operator of this vehicle should always wear a D.O.T approved helmet and other protective equipment as recommended by state and local laws. The operator should also wear face shields or goggles, boots, gloves, and other appropriate protective clothing.**
5. Unless otherwise specified in this manual, all screws, nuts, and bolts must be kept tight to ensure that the vehicle is in safe operating condition. The engine must be kept free of all dirt and other accumulations, paying particular attention to throttle linkage area.
6. Prevailing Torque type locknuts lose their locking capability with repeated use and require replacement. Ensure locknuts are functioning properly.

7. The tire pressure should be checked prior to each use. The recommended inflation pressure is the maximum tire pressure which is printed on the tire's sidewall. **Improper tire pressure may cause instability and may prevent proper braking or steering.**
8. Modification of this vehicle or removal of any original equipment or safety decals may render the vehicle unsafe or illegal. **Never remove any chained guard, or belt clutch guard.** These covers are for the riders' protection.
9. The vehicle should never be started without first checking to see that the throttle is in *idle* position. Do not start engine without verifying proper function of the throttle.
10. **Never attempt to start this vehicle without having the operator sitting in the proper position to ensure control of the kart.**
11. The operator's ability to operate this off-road vehicle safely is largely dependent upon the operator's ability to exercise proper judgement. An operator also must not be too small or too large for controlled operation. The operator must be at least 16 years of age and have understanding, mental capacity and physical capability to safely operate this vehicle. This vehicle should only be operated after mature, supervised instruction and sufficient practice in non-congested areas.
12. **This vehicle is designed for one operator only.** An operator on any vehicle must be of sufficient age, understanding, mental capacity, and physical capability to act to protect himself/herself, and wear a D.O.T approved helmet at all times. **This kart is not recommended for weights exceeding 200 pounds.**
13. The engine should be stopped when the vehicle is not in use.
14. **Loose clothing, long hair, or articles worn by any riders must be fully contained, or covered to prevent them from possibly being caught in rotating parts of the vehicle or the surrounding environment while riding. Failure to obey could endanger the personal safety of the Rider.**
15. **Do not place hands, feet, or any other part of the body or any clothing near the engine, muffler, wheels, chain, and other rotating parts of the vehicle while riding or running the engine.** Caution must be used in performing required maintenance on or near an operating engine. Special caution should be taken after the engine has been running, since the engine and other drive components may be extremely hot.
16. Wet, slippery, rough, or steep terrain is potentially dangerous and may result in injury if proper caution is not observed. Slow speeds are required to safely operate this vehicle under those conditions. The Operator must use mature judgement, skill, and experience to choose a speed suitable for the terrain and riding conditions.
17. **The Governor settings for this vehicle's engine must not be tampered with, altered or changed.** The governor is set by the engine manufacturer and limits the maximum speed of the engine (and vehicle) and protects the **engine** from damage. Excessive speeds are potentially dangerous to the rider and the engine. **The top speed for this vehicle is 34 mph.**

18. Each time before using this vehicle, the fuel supply should be checked. The fuel tank should never be filled while the engine is running or while the engine is hot. Do not fill tank in closed area such as a garage, while smoking, or in the vicinity of an open flame. Do not overfill the tank. Always allow at least ¼ inch of space at the top of the tank for expansion. Never top off tank. Replace cap tightly to prevent spillage of fuel and potential fire hazard. After filling tank, move the vehicle at least 15 feet away from spot of filling before starting.
19. If the vehicle should start making unusual noise or vibrating abnormally, the engine should be stopped and the spark plug wire disconnected. The vehicle should then be checked for damage. Excessive noise or vibration is generally a warning of loose or worn parts.
20. When making repairs or adjustments to the vehicle which do not involve adjustments to the engine, the spark plug wire must be disconnected and kept away from the spark plug to prevent accidental starting. When working on or around or when restarting engine, use extreme caution to avoid contact with the muffler, cylinder head, or any other potentially hot area on or around the engine.
21. Always perform a Pre-Ride Inspection before starting the engine. See Pre-Ride Inspection in the manual.
22. The custom brush guard assembled on this vehicle is for deflecting loose vegetation and must not be removed.
23. When storing the vehicle, it must be kept in a place where gasoline fumes will not reach an open flame or spark. For long periods of storage, such as for winter, the fuel tank should be drained in the open, cool area. The engine must be allowed to cool before storage in any enclosure. Read and keep all printed material supplied with this vehicle. Timely and specific instructions and an Operators Manual revisions are included in supplements. If any printed material included is unclear, please call 1-888-389-5522 for assistance.
24. **Never operate this vehicle while under the influence of alcohol, drugs, or medication of any kind. Such operation could be dangerous to you and/or others.**
25. Always slow down while turning. High speed turning may cause loss of control, possible injury to the Operator.
26. ***Do not race, jump, and perform "stunt" riding or "spinouts" when operating the Fun-Kart. The Fun-Kart is not designed or intended for such operation.***
27. This manual provides guidelines for the assembly, maintenance, and operation of this Fun-Kart and is not intended as a service manual.
28. Assembly, maintenance, and/or repair of this Fun-Kart should only be performed by persons of sufficient mechanical skill, experience, and judgment (such as outdoor equipment dealers, motorcycle dealer/shops, or small engine dealers) so that no unsafe condition or modification is made.
29. Always use extreme caution when starting the engine. Avoid touching the engine, muffler, or drive components. These areas could cause burns on contact.
30. **Operator must always be appropriately supervised at all times while operating this vehicle.**

31. Riding your Fun-Kart requires skill acquired through practice over a period of time. Take the time to learn the basic techniques before attempting to ride the vehicle.
32. Ride only on safe and familiar terrain. Avoid loose gravel and rocks. Be careful on wet surfaces and allow for extra braking distance.
33. ALWAYS mount the caution flag provided on the Fun-Kart for safety purposes. This flag could help prevent dangerous situations.

**Pay close attention to all *Caution* and *Warning* labels on the Fun-Kart.**

## **ASSUMPTIONS OF RISK**

*The Owner Or Operator Assumes All The Risks Incident To Or Arising Out Of The Operation Of This Vehicle.*

*Failure To Follow And Comply With All Warnings May Cause Serious Injury Or Death*

# YERF-DOG Fun-Karts by Flexible Flyer

## LIMITED WARRANTY

The *Limited Warranty* on this vehicle is in two (2) parts:

We offer the original purchaser of this product the following warranty:

### ***PART 1***

#### **ENGINE**

Tecumseh warrants the engine for (2) years, not Flexible Flyer. See Tecumseh Engine Owner's Manual. Engine repair, replacement parts, and warranty claims must be handled through an authorized dealer in your locality. Tecumseh has an extensive authorized sales and service dealer network. (See yellow pages of phone directory under "Engine-Gas").

### ***PART 2***

#### **FRAME**

The frame and related components are warranted by Flexible Flyer and are applied to any part found to be defective due to material and/or workmanship when inspected at the Flexible Flyer factory. Flexible Flyer will at its' option, repair or replace the defective parts to the original purchaser at no charge.

The warranty periods are as follows from the date of purchase:

- A. Frame for 90 days, Void if:
  - 1. Frame is broken or bent due to abuse (underside scraped abusively).
  - 2. Wheels are bent or broken due to impact.
  - 3. Spindles are bent due to impact.
  - 4. Paint is worn off of rear bumper indicating an extra rider.
  - 5. Axles are bent out of ordinary position either horizontally or vertically.
  - 6. Non-Factory altering of engine or it's components
- B. Bearings and sprocket for 30 days
- C. Clutch for 30 days against breakage of its parts. No warranty is applied for wear of clutch shoes or clutch bearings due to service.
- D. Throttle cable, brake cable, brake band, chain, tires, seat, shocks, fasteners and other components are not warranted because due to normal service they are subject to excessive wear and abuse.

All Warranties are voided if the vehicle has been altered in any way or is used in racing or competition, any commercial use or rented, used under abnormal conditions, or subject to abuse, misuse, neglect, or improper maintenance.

**Flexible Flyer is not liable for any damage claim or liability claim, personal or otherwise resulting from the operation of this vehicle in any way.**

**FLEXIBLE FLYER**  
**100 Tubb Avenue**  
**West Point, MS 39773**

**FOR REPLACEMENT PARTS PLEASE CALL:**  
**1-888-389-5522 (U.S.) 1-888-707-1880 (Canada)**

---

**ASSEMBLY**

---

1. Complete the Fun-Kart registration and warranty confirmation on the back of this owner's manual and mail in within 10 days of purchase. The information is required when ordering parts.
2. *Steering Wheel* - Bolt the steering wheel to the anchor plate with fasteners provided in the parts bag included with the Fun-Kart. See "Steering Wheel Assembly Instructions" page 12.
3. *Seat* - Install the seat frame to chassis frame with fasteners provided in the parts bag. See "Seat Assembly Instructions" page 13.
4. *Brush Guard* - Bolt the brush guard to chassis frame with fasteners provided in the parts bag. See "Brush Guard Assembly Instructions" page 14.
5. *Foam* - Attach Foam to Brush Guard. See "Foam Attachment Diagram" page 15.
6. *Bolts* - Check the screws, nuts and bolts on your vehicle to see that all are tightened securely. For safe operating conditions, do periodic checks and tighten securely.
7. **Engine** - **Fill the crankcase with oil until it reaches the FULL mark on the dip stick. DO NOT fill above the FULL mark.** Approximately 20 oz. or 1¼ pints (.6 Liters) of SAE 30 weight oil. For additional information refer to Tecumseh engine manual for servicing the engine.
8. Fill fuel tank with regular gasoline, leaded or unleaded. Do not use premium gasoline. Do not overfill (no fuel in filler neck).
9. *Tire Pressure*

**CHECK AIR PRESSURE IN TIRES!!**

It is common industry practice to overinflate the tires. This is done to guarantee an airtight seal. Prior to riding the Fun-Kart for the first time, you may need to reduce the air pressure in the tires to the specifications stated below:

	<u>Knobby Tread</u>	<u>Turf Tread</u>
Rear Tires	10 PSI	10 PSI
Front Tires	4 PSI	12 PSI

Proper tire pressures will increase the life of the tire and enhance the performance of the Fun-Kart.

**Driving on asphalt or concrete will significantly reduce the life of the tire!!**

---

## PRE-RIDE INSPECTION

---

**WARNING** - *Perform this pre-ride inspection everyday before riding the vehicle. If not performed, serious damage to the vehicle and personal injury may result.*

1. *Engine Oil Level* – Add oil if required. Check for leaks. Tighten filler cap securely.
2. *Fuel Level* – Add fuel if necessary. Do not overfill (no fuel in filler neck). Replace cap tightly. Check for leaks. Do not mix oil with gas. Only refuel when engine is off and cool.
3. *Brakes* – Perform a Brake Test: Sit in the vehicle with the brake actuated by pressing on the brake pedal. Start the engine with the ignition switch on. Increase the engine RPM gradually to ensure the brake is effective. Do not operate this Fun-Kart unless the brake is working properly.
4. *Tires* – Check conditions and pressure.
5. *Drive Chain* – Check condition, tension, lubricate as necessary.
6. *Throttle* – Check for smooth operation. Assure throttle “snaps” back to idle. Also, check for frayed cable or damaged cable conduit. If either condition exists replace the cable assembly before riding.
7. *Stop Switch* – Perform this stop switch test. While the engine is running, move the steering column remote stop switch to the “OFF” position. If this does not stop the engine, move the engine remote switch to the “OFF” position. If the engine is not equipped with an engine remote switch, pull the spark plug wire. Check to insure that the stop switch wire is attached to the terminal on the engine. **Do not operate this vehicle with a stop switch that is not functioning properly.**
8. *All Nuts, Bolts and Fasteners* – Check wheels to assure that all axle nuts and lug nuts are tightened properly. Check and tighten all other fasteners as necessary. Regularly check set screws on sprockets and drum.
9. *Guards* – Ensure all protective guards are in place. **Never remove any chain guard, or clutch guard.** Each of these covers have a protective purpose, if removed it could endanger the personal safety of the operator or passenger.
10. *Steering System* – Ensure that it turns freely.

---

## STARTING INSTRUCTIONS

---

**NOTE:** *Do not attempt to start or operate this machine without being completely familiar with all controls necessary to operate this vehicle safely. Do not start the engine before reading and understanding all the rules, warnings, and instructions in this manual.*



1. Before starting the engine, the operator should be seated in the Fun-Kart. If the rider is not seated in the vehicle, it should be placed against a stationary object and started.
2. Do not start the engine before checking to make sure the throttle assembly is in the idle position. Warning – Each time prior to starting the engine, check throttle assembly to ensure that when the throttle pedal (right side) is pushed all the way forward the assembly is working smoothly and returns to idle when released. Do not operate if pedal and engine throttle linkage fail to return to idle.
3. To start a cold engine, pump the engine primer “3” times. If the engine is hot, priming may not be necessary to restart the engine.
4. Pull recoil starter rope sharply. See Tecumseh engine owner’s manual. Do not flood the engine by continuously pulling the starter rope. If engine does not start after two or three pulls of the starter rope, wait a few minutes then repeat the above procedures.

---

## OPERATIONAL SAFETY TIPS

---

### TURNING MANUEVERS

The new rider must learn to shift his weight and control the throttle to allow the rear tires to negotiate the turn. This is the primary technique to be mastered in riding this vehicle. Practice turning at slow constant speeds. Defer increased speeds until you are confident of your proficiency and are intimately familiar with the terrain.

Steer in the direction of the turn, and lean your body to the inside of the turn in order to maximize front tire traction. Use the throttle to maintain posture throughout the turn.

Incorrect turning techniques may cause the front tires to slide straight ahead without affecting the vehicles direction of travel. If this should occur, come to a stop, then resume the technique outlined above.

If the front wheels tend to skid in mud, sand, or snow, you may be able to improve control by releasing the throttle and allowing the vehicle to coast through the turn.

If rear wheel inadvertently skid sideways, correct your slide by steering in the direction of the skid, if you have room to perform this maneuver safely. Avoid braking or accelerating until you have control.

To avoid skids while traveling on slippery terrain, the rider must exercise a high degree of caution. Turning maneuvers on slippery terrain are more hazardous than those performed under full traction and must be done slowly.

---

## PREVENTIVE MAINTENANCE

---

### STORAGE

In the event your vehicle is not to be operated for a period in excess of 30 days and at the end of riding season prepare for storage as follows:

***WARNING- Do not drain fuel while engine is hot. Be sure to move vehicle outside before draining fuel.***

1. Drain fuel tank and remove all fuel remaining in the tank by using a suction device or by soaking up the fuel with a clean rag or towel. Remove all fuel remaining in the carburetor by allowing engine to run out of fuel. Do not perform any fuel removal procedure while smoking or near an open flame. Dispose of any rags or towels properly.
2. Lubricate engine cylinder by removing the spark plug and pouring an ounce of lean lubricating oil through the spark plug hole into the cylinder. Crank the engine slowly to spread oil and replace spark plug.
3. Do not save or store gasoline over winter. Using old gasoline that has deteriorated from storage will cause hard starting and affect engine performance.
4. When the vehicle is removed from storage re-read the owner's manual, perform any assembly required, and perform a pre-ride inspection. See Pre-Ride Inspection section of this manual.

## GENERAL

Just as your automobile needs professional, mechanical maintenance from time to time, so does this vehicle. Replacement of the spark plug and ignition points is made necessary by normal use. Professional air-cooled engine service is easily obtained. Check your phone book yellow pages under "Engine Gasoline".

---

## SERVICE INSTRUCTIONS

---

*Engine Lubrication* – You must change the oil in the crankcase after the first two hours of operating your new engine and after each 25 hours of use thereafter. That will insure proper lubrication in internal parts and prevent costly repairs due to excessive wear. Refer to Engine Maintenance Instructions.

*Kart Lubrication* – Every two or three hours of use lubricate the following items with several drops of oil; steering bearing points, brake rod pivot points, pedal pivot points, steering spindles, and steering rod ends. Use the same grade of lubricating oil that is used in the engine crankcase.

*Chain Lubrication* – **For the best chain life, it should be lubricated with a graphite type of lubricant such as the spray-on type which evaporates, leaving the graphite on the chain.** Using oil or grease on the chain in dusty or sandy riding conditions may cause dirt particles to stick to the chain resulting in rapid wear from abrasion.

*Front Wheel Replacement* – Care must be used when replacing wheels. **Do not over tighten nuts.** It is only necessary to tighten the nuts so that the wheel turns freely on the axle with minimum endplay. If the wheel does not turn freely, the nut is too tight.

*Rear Wheel Replacement* – Loosen the large locknut in the center of the wheel to remove the rear wheel.

*Chain Adjustment* – After the first two hours of operation, check the chain adjustment and readjust it if it has more than 1/2" flex. Loosen the engine clamp nuts and slide the engine forward to tighten chain.

**For Replacement Parts Please Call:  
1-888-389-5522 (U.S.) 1-888-707-1880 (Canada)**

# SUSPENSION MAINTENANCE

The Suspension System on your Fun-Kart is specifically designed and set up for the smoothest possible ride, while maintaining top performance and kart durability. Your Fun-Karts suspension system uses four shock absorbers, two on the front suspension and two on the rear suspension, to comfortably tackle rough terrain.

The two front shock absorbers affect the camber or slant of your front tires. You may have noticed that your new Fun-Kart has an *extreme outward camber* or slant of the front tires as shown in **Figure A**. **This is normal**. They were set this way at the factory for ensuring maximum tread life on the front tires. There are three important reasons for this outward camber:

**1. The weight of the driver and/or passenger is not on the Kart.**

The added weight of the driver and/or passenger pushes the front and rear suspension down.

**2. The Fun-Kart is not in motion.**

When the Kart is in motion, the front suspension is forced down slightly.

**3. The shock absorbers are new and not “broken in”.**

Your new Fun-Kart needs at least one hour of use to “break in” the shocks and level out the tires. After the first 30 minutes of use, the outward camber may be reduced by one half. After 1 hour of use the tires may have *almost no or slight outward camber* as shown in **Figure B**.

When your Fun-Kart gets an *inward camber* on the front tires from shock wear as shown in **Figure C** and steering becomes difficult, the shocks will need to be readjusted. Adjust the front suspension to a *slight outward camber* as shown in **Figure B** by increasing the shocks. Adjust the shocks by following the “Shock Absorber Adjustment” instructions below. When your shocks cannot be adjusted any tighter, they must be replaced.

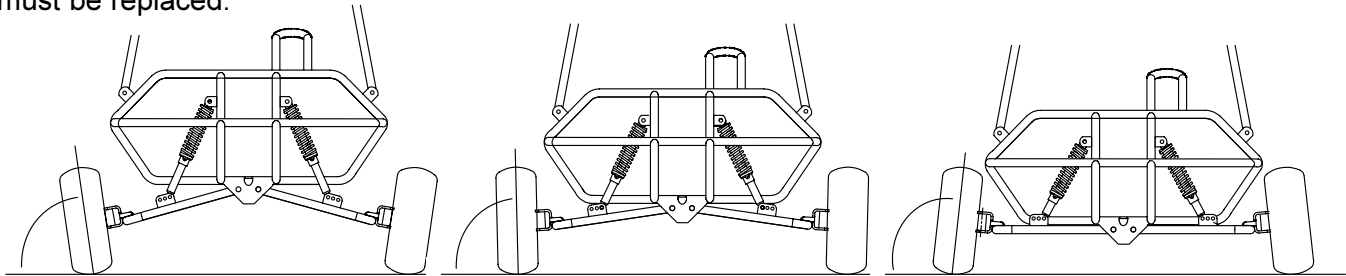

**A. EXTREME OUTWARD CAMBER**  
(NEW SHOCKS, NOT BROKEN IN)

**B. SLIGHT OUTWARD CAMBER**  
(SHOCKS BROKEN IN)

**C. INWARD CAMBER**  
(SHOCKS NEED TO BE ADJUSTED OR REPLACED)

Your Fun Kart has an added feature on the A-Arms for three quick Camber Adjustments **Figure D**.

Note: The factory attaches the shocks at position 2. You may choose to move them to position 1 and adjust shocks to set at Slight Outward Camber (Riding Position) until the shocks “break in” then either readjust the shocks as shown in “Shock Absorber Adjustment” or move to position 2. Shocks may bottom out (cannot be adjusted any tighter) before you need to set to position 3.

To adjust: Remove 3/8” x 1-3/4” Bolts and 3/8” Nylock Nuts attaching the bottom of the Shocks to the Three Hole Brackets and move to desired hole then reattach Shocks. Tighten Bolts.

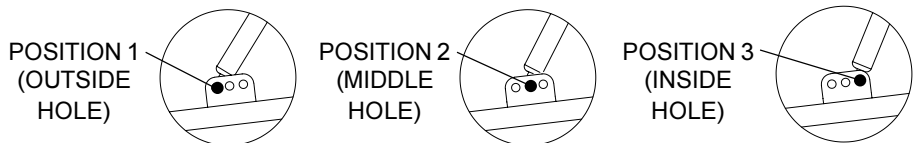
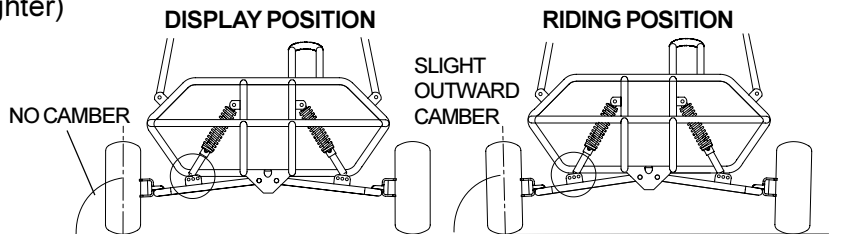

**D. THREE QUICK CAMBER ADJUSTMENTS**

NOTE: Outside holes can be used for new kart display purposes with new shocks. (Setting at “NO CAMBER”)

## SHOCK ABSORBER ADJUSTMENT

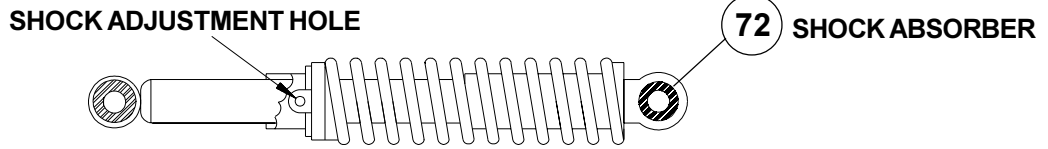

1. Locate the SHOCK ABSORBERS (72) at the front and rear of the FUN-KART
2. The SHOCKS are pre-set for normal conditions at the factory.
3. Locate the SHOCK ADJUSTMENT HOLE at the base of the spring.
4. Place the end of a narrow screwdriver in the SHOCK ADJUSTMENT HOLE.
5. Turn the SHOCK ADJUSTMENT HOLE counter-clockwise around the SHOCK to decrease shock absorption.
6. Turn the SHOCK ADJUSTMENT HOLE clockwise around the SHOCK to increase shock absorption.
7. Experiment with the adjustment until the desired effect is attained.

## STEERING WHEEL ASSEMBLY INSTRUCTIONS

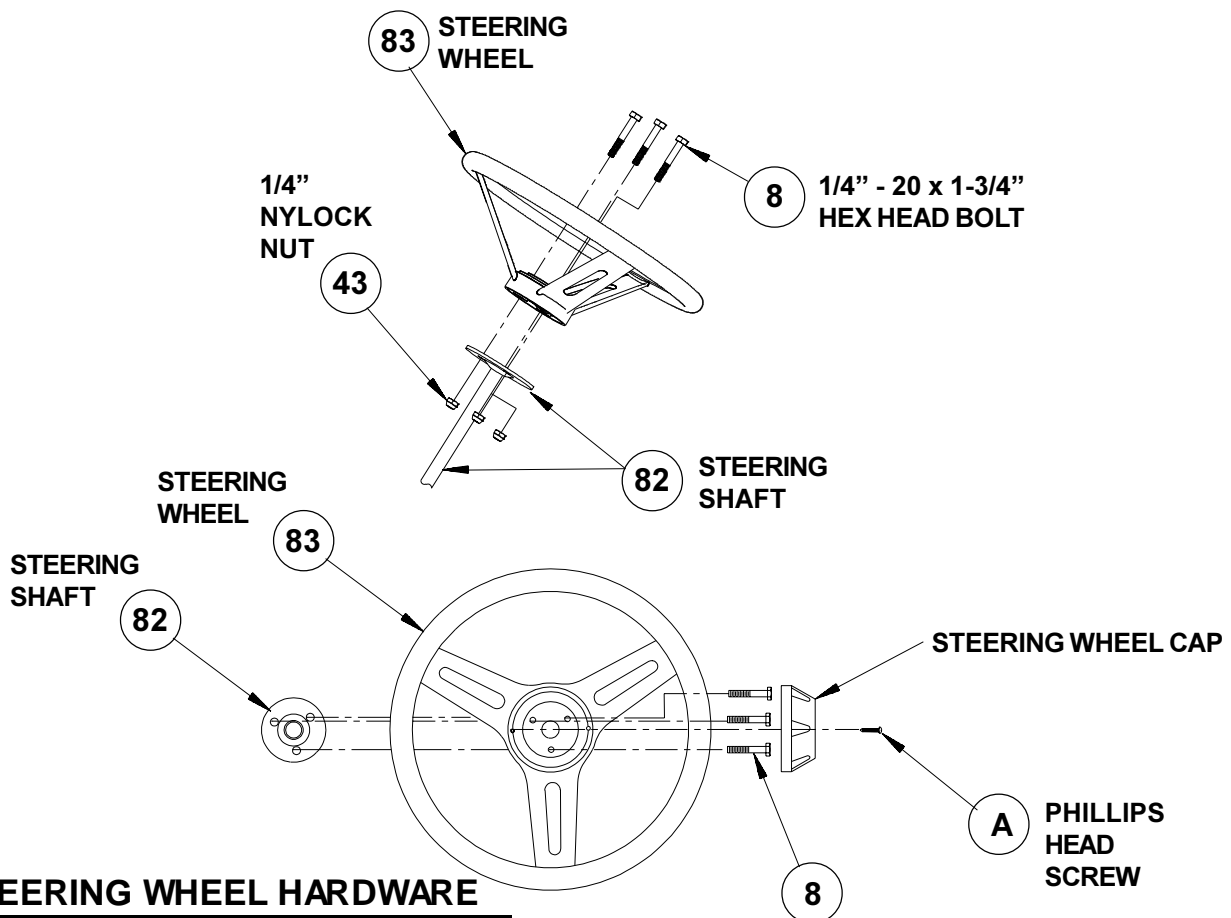

### STEERING WHEEL HARDWARE

Item	Description	Qty.
8	BOLT, 1/4"-20 X 1-3/4" HEX	3
43	NUT, 1/4" - 20 LOCK	3
A	SCREW	1

1/4" - 20 x 1-3/4"  
HEX HEAD BOLT

# SEAT ASSEMBLY INSTRUCTIONS

1. Locate the SEAT FRAME ASSEMBLY, LAP BELT, and SHOULDER BELT.
2. Align STUDS on the bottom of the SEAT FRAME ASSEMBLY with the SEAT TAB HOLES on the FUN-KART FRAME.
3. Slip SHOULDER BELT and LAP BELT connectors under the rear STUDS on the bottom of the SEAT FRAME ASSEMBLY.
4. Insert STUDS into SEAT TAB HOLES.
5. Secure the SEAT FRAME ASSEMBLY using the hardware shown.
6. Place the SEAT CUSHION on the SEAT FRAME ASSEMBLY. Secure the SEAT CUSHION to the SEAT FRAME ASSEMBLY using the hardware shown.

## SEAT HARDWARE

Item	Description	Qty.
8	BOLT, 1/4"-20 X 1-3/4" HEX	1
47	NUT, 5/16" LOCK	4
89	WASHER, 5/16" FLAT	4
104	WASHER, 5/16" LOCK	1

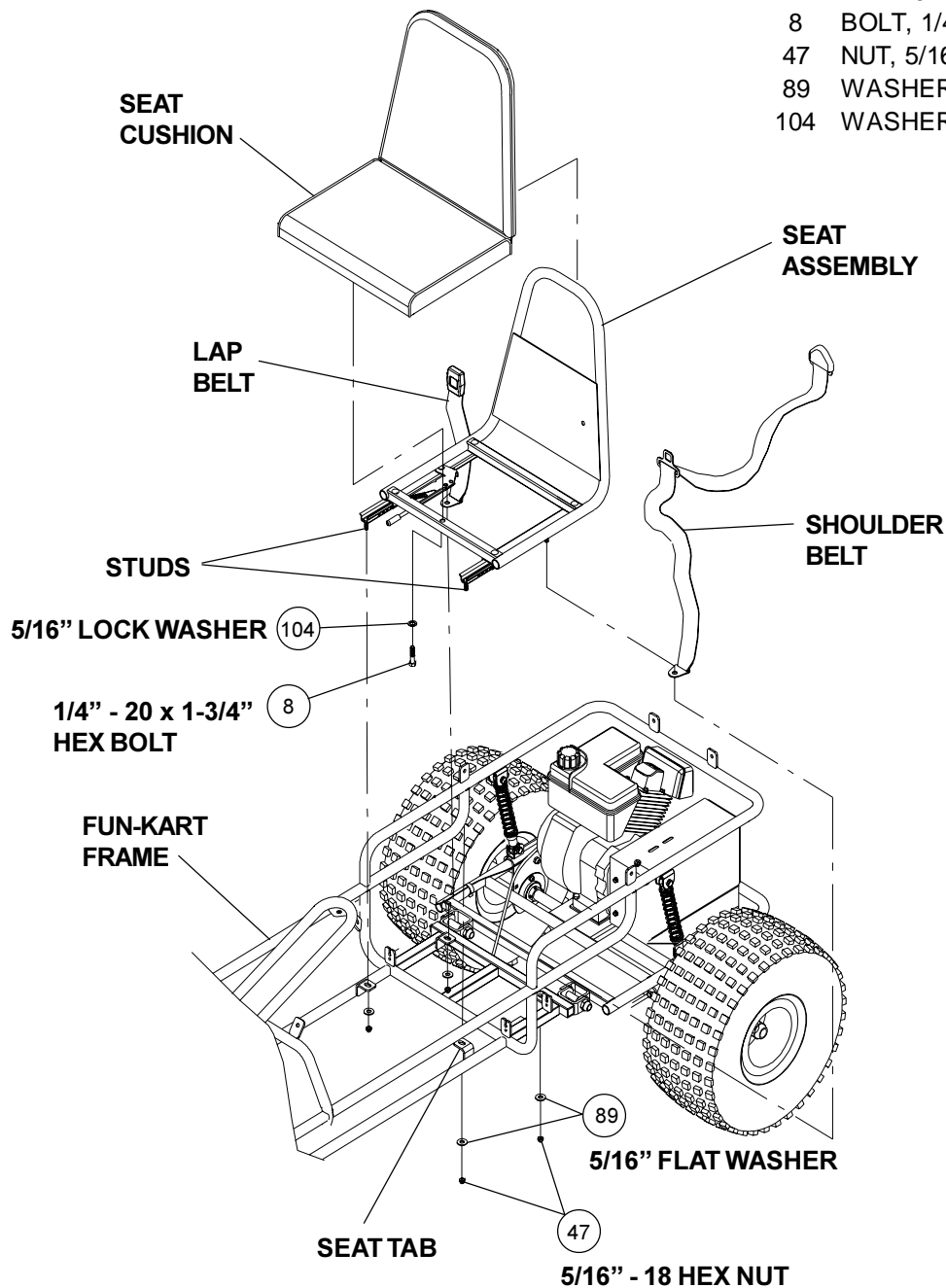

# BRUSH GUARD ASSEMBLY INSTRUCTIONS

1. Secure the MAIN BRUSH GUARD (21) to the middle tabs on the FUN-KART FRAME, behind the SEAT, using the hardware shown.
2. Secure the REAR BRUSH GUARD (51) and SAFETY FLAG (34) to the rear tabs on the FRAME using the hardware shown.
3. Align holes and secure the REAR BRUSH GUARDS (51) to the top of the MAIN BRUSH GUARD (21) using the hardware shown.
4. Secure the FRONT BRUSH GUARD (20) to the front tabs on the FRAME using the hardware shown.
5. Join and secure the FRONT BRUSH GUARD (20) to the ends of the REAR BRUSH GUARDS (51) using the hardware shown.
6. Mount the end of the SHOULDER BELT to the side of the MAIN BRUSH GUARD (21) using the hardware shown.  
**NOTE:** Do not overtighten the hardware attaching the end of the SHOULDER BELT. The BELT must rotate.
7. For added security, strap the SAFETY FLAG (34) tightly to the the REAR BRUSH GUARD (51) using WHITE CABLE TIE (35). Cut off and discard the excess CABLE TIE.

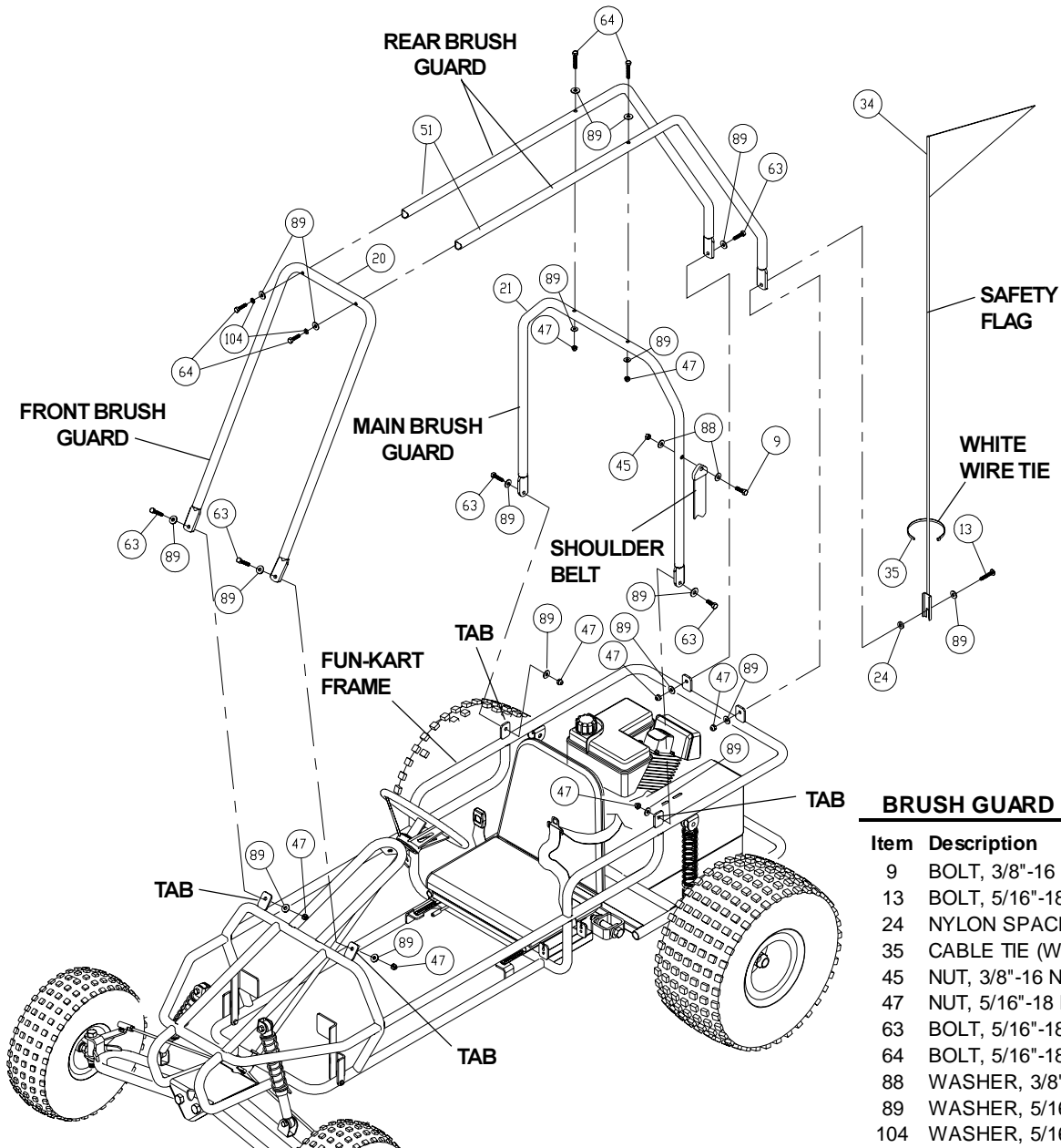

## BRUSH GUARD HARDWARE

Item	Description	Qty.
9	BOLT, 3/8"-16 X 1-3/4" HEX	1
13	BOLT, 5/16"-18 X 1-1/2" HEX	1
24	NYLON SPACER	1
35	CABLE TIE (WHITE)	1
45	NUT, 3/8"-16 NYLOCK	1
47	NUT, 5/16"-18 HEX	8
63	BOLT, 5/16"-18 X 1" HEX	5
64	BOLT, 5/16"-18 X 2-1/4" HEX	4
88	WASHER, 3/8" FLAT	2
89	WASHER, 5/16" FLAT	18
104	WASHER, 5/16" LOCK	2

---

## FOAM ATTACHMENT DIAGRAM

---

Attach FOAM (87) to the BRUSH GUARDS using CABLE TIES (81) as shown.

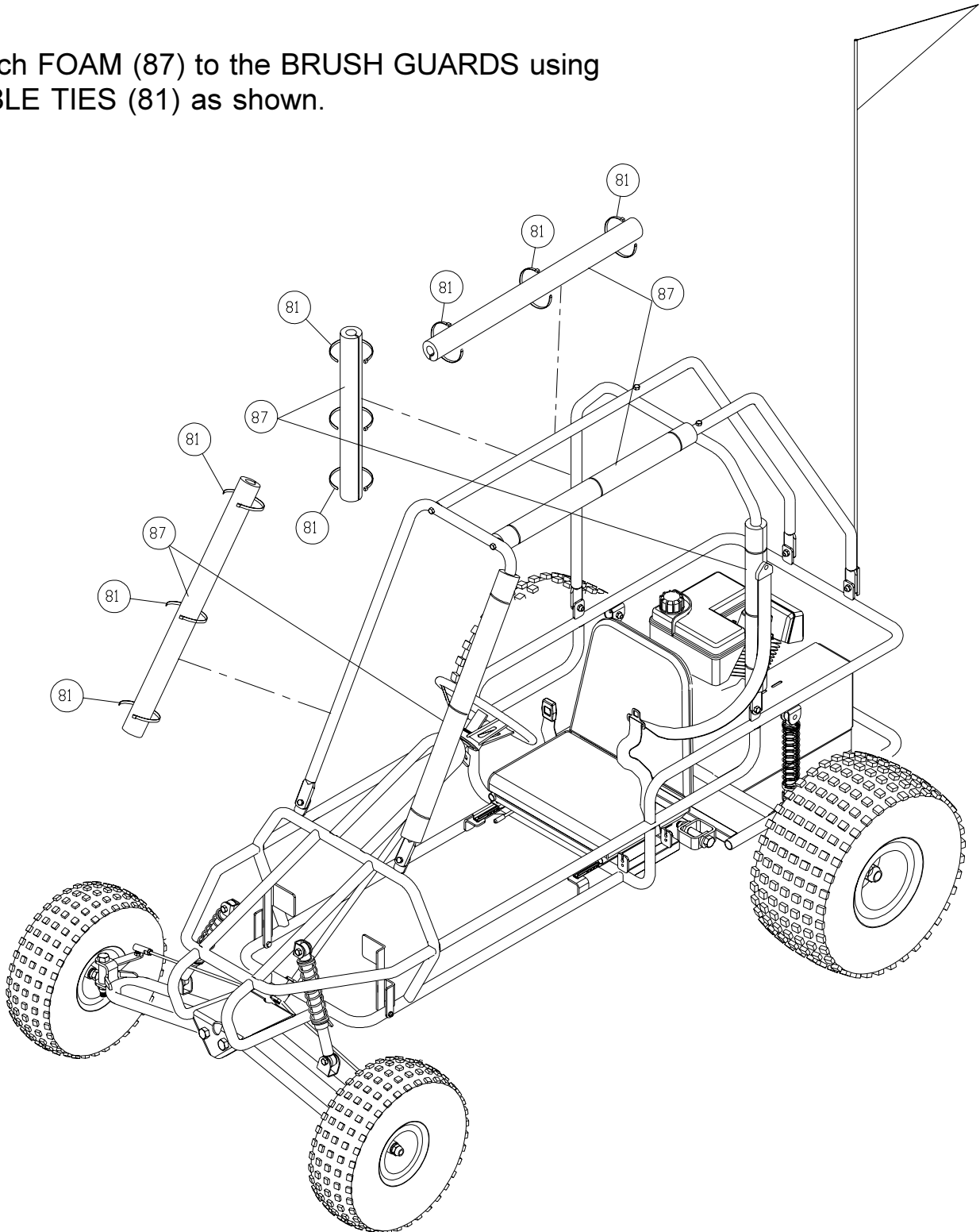

---

## SUGGESTED DECAL APPLICATION

---

Apply Decal kit (00918) as shown in the illustrations below.  
(Note: Decals are self-adhesive and require no glue.)

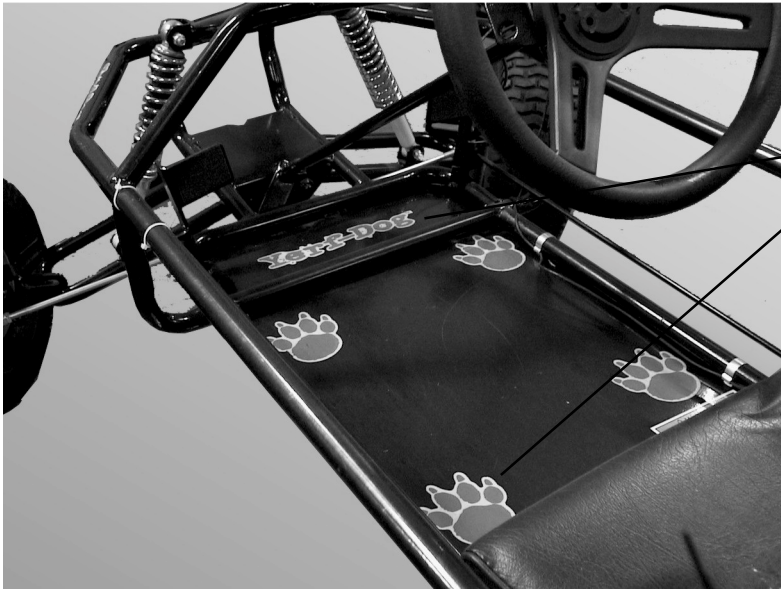

Yerf Dog logo (1) and  
Paw Prints (4).

Yerf Dog logo (2)  
applied to both  
sides of front.



Yerf Dog logo (2)  
applied to both  
sides of rear.



## 32001 SERIES REPLACEMENT PARTS IDENTIFICATION

Item	Part No.	Description	Item	Part No.	Description
1	01263	A-ARM, BLACK LEFT	57	27000100	SPRING PIN, 1/4 X 7/8"
2	01264	A-ARM, BLACK RIGHT	58	001474P	SCREW, SHEET METAL, #10 x 1/2"
3	H93110W	BEARING RETAINER	59	22001400	BOLT, 1/4-20 X 1-1/2" HEX SHOULDER
4	H92010W	BEARING, 1" I.D.	60	01225	BOLT, 5/16-18 X 5/8" HEX
5	H99502W	BEARING, 5/8" I.D.	61	00922	BOLT, 3/8-16 X 1-1/2" HEX
6	H93290W	BOLT, 5/16-18 X 1-1/2" CARRIAGE	62	00920	BOLT, 3/8-16 X 2" CARRIAGE
7	H33135W	BOLT, 5/16-18 X 1-3/4" HEX	63	2200040	BOLT, 5/16-18 X 1" HEX
8	H32503W	BOLT, 1/4 -20 X 1-3/4" HEX	64	00996	BOLT, 5/16-18 X 2-1/4" HEX
9	22000300	BOLT, 3/8-16 X 1-3/4" HEX	65	26000900	SEAT BELT ASSEMBLY
10	22000900	BOLT, 3/8-16 X 2"	66	H92440W	SEAT CUSHION
11	H33137W	BOLT, 3/8-16X 1" CARRIAGE	67	5311069	SEAT FRAME, BLACK
12	H95188W	BOLT, 5/16-18 X 3/4" CARRIAGE	68	H92740W	SEAT RAIL, PAIR
13	2200030	BOLT, 5/16-18 X 1-1/2" HEX	69	H93200W	SET SCREW, 1/4-28 X 1/4"
14	H33136W	BOLT, 5/16-24 X 1/2" HEX	70	01964	SPACER TUBE, BEARING
15	H36254W	BOLT, 5/8-18 X 3-3/4" HEX	71	01132	SHAFT, REAR AXLE
16	22001700	BOLT, 5/8-18 X 7" HEX	72	02972B	SHOCK ABSORBER
17	H92130W	BRAKE BAND	73	00951	SLEEVE, 13-1/8" PVC
18	01135	BRAKE CABLE, 21-1/2"	74	00983	SLEEVE, 4-5/8" PVC
19	H92140W	BRAKE DRUM, 4" DIA	75	01133	SPACER, 0.78 I.D. DRIVE
20	01458	BRUSH GUARD, BLACK FRONT	76	32010606	SPINDLE, BLACK LEFT
21	01461	BRUSH GUARD, BLACK MAIN	77	32010506	SPINDLE, BLACK RIGHT
22	31004600	CABLE ATTACHMENT, BLACK	78	H55030W	SPRING, 1/2" X 3" COMPRESSION
23	M01001W	CABLE TIE, 3-1/4" BLACK	79	23001100	SPROCKET ASSEMBLY
24	001467P	NYLON SPACER	80	H92541W	SPROCKET, 10 TOOTH
25	H91480W	COLLAR, 7/16" BORE X 7/8"	81	M12501W	CABLE TIE, 11", BLACK
26	35000600	CONTROL ROD, BLACK ZINC	82	32015206	STEERING SHAFT, BLACK
27	00918	DECAL, KIT	83	H92561W	STEERING WHEEL, 13" W/CAP
28	Q43203W	DRIVE BELT, COMET	84	36000700	THROTTLE CABLE, 40"
29	00994	DRIVE CHAIN	85	23001700	TIE ROD ASSEMBLY
30	02908	DRIVE COVER, BLACK	86	001812P	WASHER, 1/4" FLAT
31	Q43200W	DRIVEN, TORQUE CONVERTER	87	M72038W	FOAM, BLACK
32	Q43201W	DRIVER, TORQUE CONVERTER	88	001616P	WASHER, 3/8" SPECIAL FLAT
33	Q43160W	ENGINE, 6.0 HP TECUMSEH	89	001618P	WASHER, 5/16" FLAT
34	H92700W	FLAG, SAFETY	90	H53132W	WASHER, 5/16" INTERNAL TOOTH
35	M13501W	CABLE TIE, 23"	91	H56251W	WASHER, 5/8" NARROW FLAT
36	H91820W	FOOT PEDAL, LEFT	92	46000200	WHEEL, FRONT, CHROME RIMS, KNOBBY
37	H91830W	FOOT PEDAL, RIGHT		46000010	WHEEL, FRONT, SILVER RIMS, KNOBBY
38	2014	JACKSHAFT, 5/8" W/WASHER		46000030	WHEEL, FRONT, GREY RIMS, TURF
39	H92250W	KEY, 1/4" X 1/4" X 2"	93	46000300	WHEEL, REAR, CHROME RIMS, KNOBBY
40	01134	KEY, 3/16" X 3/16" X 3-1/4"		46000020	WHEEL, REAR, SILVER RIMS, KNOBBY
41	Q33100W	KILL SWITCH ASSEMBLY		46000040	WHEEL, REAR, GREY RIMS, TURF
			94	925	WIRE ASSY, 16 GA X 107"
43	001203P	NUT, 1/4-20 NYLOCK	95	H92690W	WIRE CLIP
44	HH10014	NUT, 1-14 THIN NYLOCK	96	00513	SPINDLE SPACER
45	001205P	NUT, 3/8-16 NYLOCK	97	01443	MAIN FRAME, BLACK
46	00995	NUT, 3/8-16 JAM	98	00954	REAR SWINGARM, BLACK
47	HH1256T	NUT, 5/16-18 NYLOCK	99	01187	BOLT, 9/16-18 X 3-3/4" HEX
48	HH62518	NUT, 5/8-18 THIN NYLOC	100	01067	KEY, 1/4" X 1/4" X 1"
49	HH37524	NUT, HEX 3/8-24 THIN NYLOCK	101	01226	NUT, 5/16-18 JAM
50	32015306	PITMAN ARM, BLACK	102	01188	NUT, 9/16-18 THIN NYLOCK
51	00941	BRUSH GUARD, BLACK REAR	103	00919	SLEEVE, 2-3/8" PVC
			104	000891P	WASHER, 5/16" LOCK
53	3258	PLATE, CLUTCH MOUNT BLACK	105	03152	CAP, VINYL.37ID x .25
54	00923	PLATE, COVER MOUNT	106	H32505W	SCREW, 1/4-20 X 0.50 HEX
55	01528	RETAINING RING, 1" HEAVY		02604	4-CYCLE ENGINE OIL, SAE 30, 20 oz.
56	H91470W	RETAINING RING, 1/4"		01465	OWNER'S MANUAL, 32001 SERIES FUN-KART
				H91780W	OWNER'S MANUAL, ENGINE

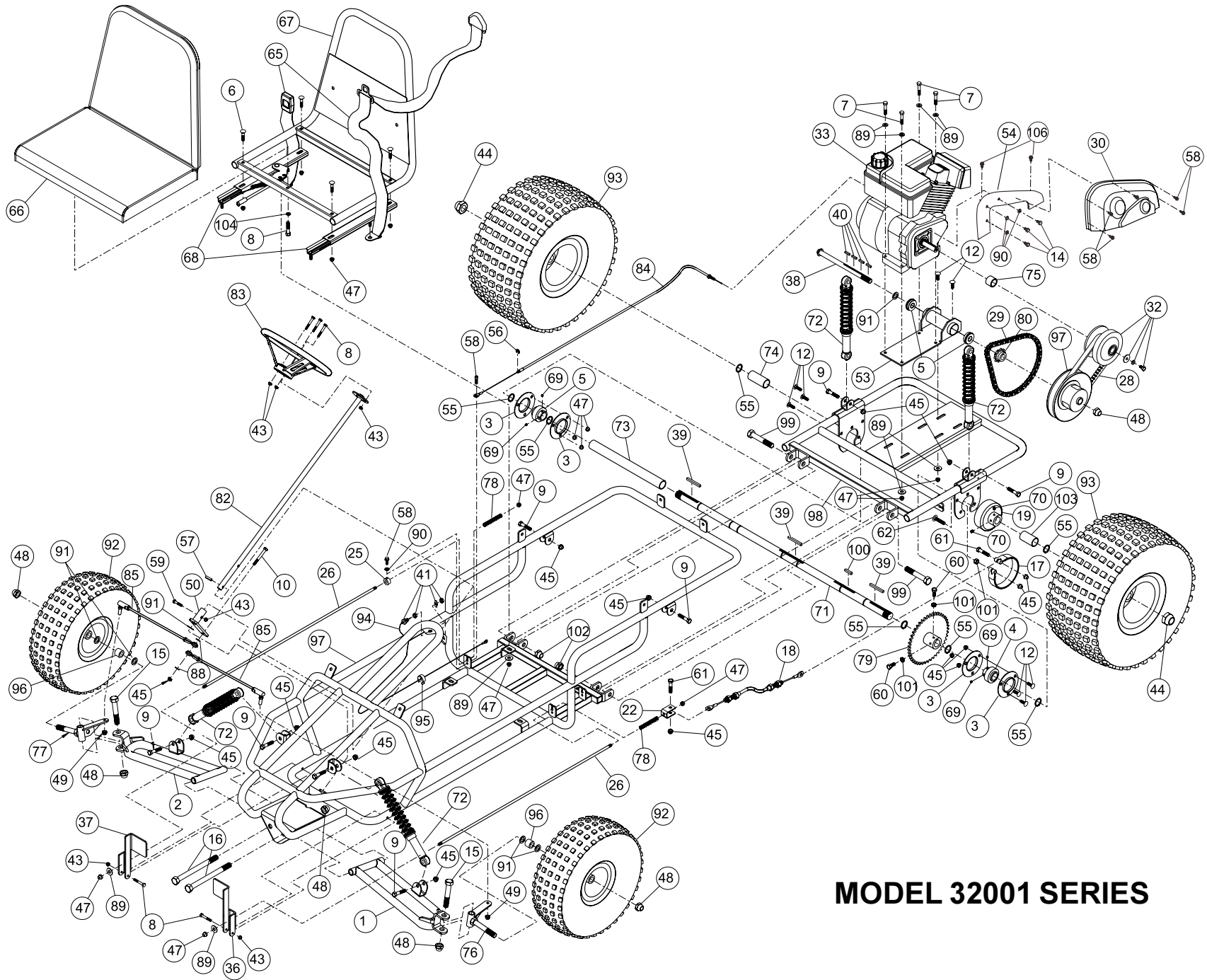

**MODEL 32001 SERIES**

# VEHICLE REGISTRATION AND WARRANTY CONFIRMATION

## **IMPORTANT!**

*Please return this information within 10 days of purchase to validate your warranty.*

*Return to:*

**F.F. Acquisition Corp.  
YERF-DOG Warranty Dept.  
P.O. Box 1296  
West Point, MS 39773**

Thank-you for purchasing this fine YERF-DOG product. With proper use, maintenance and service this kart will bring many years of fun and enjoyment. Please complete this vehicle registration and warranty confirmation form to ensure protection under the terms and conditions of the warranty and to verify ownership of this product.

To ensure maximum safety while operating your YERF-DOG Fun Kart, observe the following precautions:

**OPERATE THIS KART OFF ROAD ONLY  
ADULT SUPERVISION FOR OPERATORS UNDER 16 YEARS OLD  
WEAR A D.O.T. APPROVED HELMET, PROTECTIVE EYE WEAR, AND CLOTHING  
SECURE LONG HAIR AND LOOSE CLOTHING; KEEP ARMS, LEGS, AND FEET INSIDE THE KART  
DO NOT OPERATE UNDER THE INFLUENCE OF DRUGS OR ALCOHOL**

To ensure maximum owner satisfaction and understanding of this product, you should:

**READ OWNERS MANUAL BEFORE OPERATING KART  
REVIEW AND FULLY UNDERSTAND THE KART AND ENGINE WARRANTIES  
INSPECT THE KART UPON DELIVERY  
SECURE A COMPLETED COPY OF THIS CERTIFICATE FOR YOUR RECORDS**

In signing this document, the purchaser acknowledges that he/she understands the warranty limitations, safety, and maintenance guidelines outlined above and in the owner's manual and, therefore, agrees that all riders/operators will adhere to these specifications.

---

Model No.

Serial No.

Date of Purchase

---

First Name

Initial

Last Name

---

Street Address

---

City

State

Zip Code

---

Home Telephone Number

Parent's Signature

**(Please enclose a copy of your proof of purchase.)**

---