

POWER FEED™ 10A CONTROLLER

For use with machines having Code Numbers: **11139**

Safety Depends on You

Lincoln arc welding and cutting equipment is designed and built with safety in mind. However, your overall safety can be increased by proper installation ... and thoughtful operation on your part. **DO NOT INSTALL, OPERATE OR REPAIR THIS EQUIPMENT WITHOUT READING THIS MANUAL AND THE SAFETY PRECAUTIONS CONTAINED THROUGHOUT.** And, most importantly, think before you act and be careful.



IP 21S

OPERATOR'S MANUAL

LINCOLN[®]
ELECTRIC

Copyright © Lincoln Global Inc.

- World's Leader in Welding and Cutting Products •
- Sales and Service through Subsidiaries and Distributors Worldwide •

Cleveland, Ohio 44117-1199 U.S.A. TEL: 216.481.8100 FAX: 216.486.1751 WEB SITE: www.lincolnelectric.com

⚠ WARNING

⚠ CALIFORNIA PROPOSITION 65 WARNINGS ⚠

Diesel engine exhaust and some of its constituents are known to the State of California to cause cancer, birth defects, and other reproductive harm.

The Above For Diesel Engines

The engine exhaust from this product contains chemicals known to the State of California to cause cancer, birth defects, or other reproductive harm.

The Above For Gasoline Engines

ARC WELDING CAN BE HAZARDOUS. PROTECT YOURSELF AND OTHERS FROM POSSIBLE SERIOUS INJURY OR DEATH. KEEP CHILDREN AWAY. PACEMAKER WEARERS SHOULD CONSULT WITH THEIR DOCTOR BEFORE OPERATING.

Read and understand the following safety highlights. For additional safety information, it is strongly recommended that you purchase a copy of "Safety in Welding & Cutting - ANSI Standard Z49.1" from the American Welding Society, P.O. Box 351040, Miami, Florida 33135 or CSA Standard W117.2-1974. A Free copy of "Arc Welding Safety" booklet E205 is available from the Lincoln Electric Company, 22801 St. Clair Avenue, Cleveland, Ohio 44117-1199.

BE SURE THAT ALL INSTALLATION, OPERATION, MAINTENANCE AND REPAIR PROCEDURES ARE PERFORMED ONLY BY QUALIFIED INDIVIDUALS.



FOR ENGINE powered equipment.

1.a. Turn the engine off before troubleshooting and maintenance work unless the maintenance work requires it to be running.



1.b. Operate engines in open, well-ventilated areas or vent the engine exhaust fumes outdoors.



1.c. Do not add the fuel near an open flame welding arc or when the engine is running. Stop the engine and allow it to cool before refueling to prevent spilled fuel from vaporizing on contact with hot engine parts and igniting. Do not spill fuel when filling tank. If fuel is spilled, wipe it up and do not start engine until fumes have been eliminated.

1.d. Keep all equipment safety guards, covers and devices in position and in good repair. Keep hands, hair, clothing and tools away from V-belts, gears, fans and all other moving parts when starting, operating or repairing equipment.

1.e. In some cases it may be necessary to remove safety guards to perform required maintenance. Remove guards only when necessary and replace them when the maintenance requiring their removal is complete. Always use the greatest care when working near moving parts.



1.f. Do not put your hands near the engine fan. Do not attempt to override the governor or idler by pushing on the throttle control rods while the engine is running.

1.g. To prevent accidentally starting gasoline engines while turning the engine or welding generator during maintenance work, disconnect the spark plug wires, distributor cap or magneto wire as appropriate.



1.h. To avoid scalding, do not remove the radiator pressure cap when the engine is hot.



ELECTRIC AND MAGNETIC FIELDS may be dangerous

2.a. Electric current flowing through any conductor causes localized Electric and Magnetic Fields (EMF). Welding current creates EMF fields around welding cables and welding machines

2.b. EMF fields may interfere with some pacemakers, and welders having a pacemaker should consult their physician before welding.

2.c. Exposure to EMF fields in welding may have other health effects which are now not known.

2.d. All welders should use the following procedures in order to minimize exposure to EMF fields from the welding circuit:

2.d.1. Route the electrode and work cables together - Secure them with tape when possible.

2.d.2. Never coil the electrode lead around your body.

2.d.3. Do not place your body between the electrode and work cables. If the electrode cable is on your right side, the work cable should also be on your right side.

2.d.4. Connect the work cable to the workpiece as close as possible to the area being welded.

2.d.5. Do not work next to welding power source.

Mar '95



ELECTRIC SHOCK can kill.

- 3.a. The electrode and work (or ground) circuits are electrically “hot” when the welder is on. Do not touch these “hot” parts with your bare skin or wet clothing. Wear dry, hole-free gloves to insulate hands.
- 3.b. Insulate yourself from work and ground using dry insulation. Make certain the insulation is large enough to cover your full area of physical contact with work and ground.

In addition to the normal safety precautions, if welding must be performed under electrically hazardous conditions (in damp locations or while wearing wet clothing; on metal structures such as floors, gratings or scaffolds; when in cramped positions such as sitting, kneeling or lying, if there is a high risk of unavoidable or accidental contact with the workpiece or ground) use the following equipment:

- Semiautomatic DC Constant Voltage (Wire) Welder.
- DC Manual (Stick) Welder.
- AC Welder with Reduced Voltage Control.

- 3.c. In semiautomatic or automatic wire welding, the electrode, electrode reel, welding head, nozzle or semiautomatic welding gun are also electrically “hot”.
- 3.d. Always be sure the work cable makes a good electrical connection with the metal being welded. The connection should be as close as possible to the area being welded.
- 3.e. Ground the work or metal to be welded to a good electrical (earth) ground.
- 3.f. Maintain the electrode holder, work clamp, welding cable and welding machine in good, safe operating condition. Replace damaged insulation.
- 3.g. Never dip the electrode in water for cooling.
- 3.h. Never simultaneously touch electrically “hot” parts of electrode holders connected to two welders because voltage between the two can be the total of the open circuit voltage of both welders.
- 3.i. When working above floor level, use a safety belt to protect yourself from a fall should you get a shock.
- 3.j. Also see Items 6.c. and 8.



ARC RAYS can burn.

- 4.a. Use a shield with the proper filter and cover plates to protect your eyes from sparks and the rays of the arc when welding or observing open arc welding. Headshield and filter lens should conform to ANSI Z87.1 standards.
- 4.b. Use suitable clothing made from durable flame-resistant material to protect your skin and that of your helpers from the arc rays.
- 4.c. Protect other nearby personnel with suitable, non-flammable screening and/or warn them not to watch the arc nor expose themselves to the arc rays or to hot spatter or metal.



FUMES AND GASES can be dangerous.

- 5.a. Welding may produce fumes and gases hazardous to health. Avoid breathing these fumes and gases. When welding, keep your head out of the fume. Use enough ventilation and/or exhaust at the arc to keep fumes and gases away from the breathing zone. **When welding with electrodes which require special ventilation such as stainless or hard facing (see instructions on container or MSDS) or on lead or cadmium plated steel and other metals or coatings which produce highly toxic fumes, keep exposure as low as possible and within applicable OSHA PEL and ACGIH TLV limits using local exhaust or mechanical ventilation. In confined spaces or in some circumstances, outdoors, a respirator may be required. Additional precautions are also required when welding on galvanized steel.**
- 5.b. The operation of welding fume control equipment is affected by various factors including proper use and positioning of the equipment, maintenance of the equipment and the specific welding procedure and application involved. Worker exposure level should be checked upon installation and periodically thereafter to be certain it is within applicable OSHA PEL and ACGIH TLV limits.
- 5.c. Do not weld in locations near chlorinated hydrocarbon vapors coming from degreasing, cleaning or spraying operations. The heat and rays of the arc can react with solvent vapors to form phosgene, a highly toxic gas, and other irritating products.
- 5.d. Shielding gases used for arc welding can displace air and cause injury or death. Always use enough ventilation, especially in confined areas, to insure breathing air is safe.
- 5.e. Read and understand the manufacturer’s instructions for this equipment and the consumables to be used, including the material safety data sheet (MSDS) and follow your employer’s safety practices. MSDS forms are available from your welding distributor or from the manufacturer.
- 5.f. Also see item 1.b.

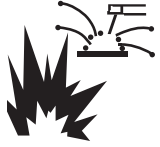

WELDING and CUTTING SPARKS can cause fire or explosion.

6.a. Remove fire hazards from the welding area. If this is not possible, cover them to prevent the welding sparks from starting a fire.

Remember that welding sparks and hot materials from welding can easily go through small cracks and openings to adjacent areas. Avoid welding near hydraulic lines. Have a fire extinguisher readily available.

- 6.b. Where compressed gases are to be used at the job site, special precautions should be used to prevent hazardous situations. Refer to "Safety in Welding and Cutting" (ANSI Standard Z49.1) and the operating information for the equipment being used.
- 6.c. When not welding, make certain no part of the electrode circuit is touching the work or ground. Accidental contact can cause overheating and create a fire hazard.
- 6.d. Do not heat, cut or weld tanks, drums or containers until the proper steps have been taken to insure that such procedures will not cause flammable or toxic vapors from substances inside. They can cause an explosion even though they have been "cleaned". For information, purchase "Recommended Safe Practices for the Preparation for Welding and Cutting of Containers and Piping That Have Held Hazardous Substances", AWS F4.1 from the American Welding Society (see address above).
- 6.e. Vent hollow castings or containers before heating, cutting or welding. They may explode.
- 6.f. Sparks and spatter are thrown from the welding arc. Wear oil free protective garments such as leather gloves, heavy shirt, cuffless trousers, high shoes and a cap over your hair. Wear ear plugs when welding out of position or in confined places. Always wear safety glasses with side shields when in a welding area.
- 6.g. Connect the work cable to the work as close to the welding area as practical. Work cables connected to the building framework or other locations away from the welding area increase the possibility of the welding current passing through lifting chains, crane cables or other alternate circuits. This can create fire hazards or overheat lifting chains or cables until they fail.
- 6.h. Also see item 1.c.
- 6.i. Read and follow NFPA 51B "Standard for Fire Prevention During Welding, Cutting and Other Hot Work", available from NFPA, 1 Batterymarch Park, PO box 9101, Quincy, Ma 022690-9101.
- 6.j. Do not use a welding power source for pipe thawing.



CYLINDER may explode if damaged.

- 7.a. Use only compressed gas cylinders containing the correct shielding gas for the process used and properly operating regulators designed for the gas and pressure used. All hoses, fittings, etc. should be suitable for the application and maintained in good condition.
- 7.b. Always keep cylinders in an upright position securely chained to an undercarriage or fixed support.
- 7.c. Cylinders should be located:
 - Away from areas where they may be struck or subjected to physical damage.
 - A safe distance from arc welding or cutting operations and any other source of heat, sparks, or flame.
- 7.d. Never allow the electrode, electrode holder or any other electrically "hot" parts to touch a cylinder.
- 7.e. Keep your head and face away from the cylinder valve outlet when opening the cylinder valve.
- 7.f. Valve protection caps should always be in place and hand tight except when the cylinder is in use or connected for use.
- 7.g. Read and follow the instructions on compressed gas cylinders, associated equipment, and CGA publication P-1, "Precautions for Safe Handling of Compressed Gases in Cylinders," available from the Compressed Gas Association 1235 Jefferson Davis Highway, Arlington, VA 22202.



FOR ELECTRICALLY powered equipment.

- 8.a. Turn off input power using the disconnect switch at the fuse box before working on the equipment.
- 8.b. Install equipment in accordance with the U.S. National Electrical Code, all local codes and the manufacturer's recommendations.
- 8.c. Ground the equipment in accordance with the U.S. National Electrical Code and the manufacturer's recommendations.

Refer to <http://www.lincolnelectric.com/safety> for additional safety information.

PRÉCAUTIONS DE SÛRETÉ

Pour votre propre protection lire et observer toutes les instructions et les précautions de sûreté spécifiques qui paraissent dans ce manuel aussi bien que les précautions de sûreté générales suivantes:

Sûreté Pour Soudage A L'Arc

1. Protégez-vous contre la secousse électrique:
 - a. Les circuits à l'électrode et à la pièce sont sous tension quand la machine à souder est en marche. Eviter toujours tout contact entre les parties sous tension et la peau nue ou les vêtements mouillés. Porter des gants secs et sans trous pour isoler les mains.
 - b. Faire très attention de bien s'isoler de la masse quand on soude dans des endroits humides, ou sur un plancher métallique ou des grilles métalliques, principalement dans les positions assis ou couché pour lesquelles une grande partie du corps peut être en contact avec la masse.
 - c. Maintenir le porte-électrode, la pince de masse, le câble de soudage et la machine à souder en bon et sûr état de fonctionnement.
 - d. Ne jamais plonger le porte-électrode dans l'eau pour le refroidir.
 - e. Ne jamais toucher simultanément les parties sous tension des porte-électrodes connectés à deux machines à souder parce que la tension entre les deux pinces peut être le total de la tension à vide des deux machines.
 - f. Si on utilise la machine à souder comme une source de courant pour soudage semi-automatique, ces précautions pour le porte-électrode s'appliquent aussi au pistolet de soudage.
2. Dans le cas de travail au dessus du niveau du sol, se protéger contre les chutes dans le cas où on reçoit un choc. Ne jamais enrouler le câble-électrode autour de n'importe quelle partie du corps.
3. Un coup d'arc peut être plus sévère qu'un coup de soleil, donc:
 - a. Utiliser un bon masque avec un verre filtrant approprié ainsi qu'un verre blanc afin de se protéger les yeux du rayonnement de l'arc et des projections quand on soude ou quand on regarde l'arc.
 - b. Porter des vêtements convenables afin de protéger la peau de soudeur et des aides contre le rayonnement de l'arc.
 - c. Protéger l'autre personnel travaillant à proximité au soudage à l'aide d'écrans appropriés et non-inflammables.
4. Des gouttes de laitier en fusion sont émises de l'arc de soudage. Se protéger avec des vêtements de protection libres de l'huile, tels que les gants en cuir, chemise épaisse, pantalons sans revers, et chaussures montantes.

5. Toujours porter des lunettes de sécurité dans la zone de soudage. Utiliser des lunettes avec écrans latéraux dans les zones où l'on pique le laitier.
6. Eloigner les matériaux inflammables ou les recouvrir afin de prévenir tout risque d'incendie dû aux étincelles.
7. Quand on ne soude pas, poser la pince à un endroit isolé de la masse. Un court-circuit accidentel peut provoquer un échauffement et un risque d'incendie.
8. S'assurer que la masse est connectée le plus près possible de la zone de travail qu'il est pratique de le faire. Si on place la masse sur la charpente de la construction ou d'autres endroits éloignés de la zone de travail, on augmente le risque de voir passer le courant de soudage par les chaînes de levage, câbles de grue, ou autres circuits. Cela peut provoquer des risques d'incendie ou d'échauffement des chaînes et des câbles jusqu'à ce qu'ils se rompent.
9. Assurer une ventilation suffisante dans la zone de soudage. Ceci est particulièrement important pour le soudage de tôles galvanisées plombées, ou cadmiées ou tout autre métal qui produit des fumées toxiques.
10. Ne pas souder en présence de vapeurs de chlore provenant d'opérations de dégraissage, nettoyage ou pistologie. La chaleur ou les rayons de l'arc peuvent réagir avec les vapeurs du solvant pour produire du phosgène (gas fortement toxique) ou autres produits irritants.
11. Pour obtenir de plus amples renseignements sur la sûreté, voir le code "Code for safety in welding and cutting" CSA Standard W 117.2-1974.

PRÉCAUTIONS DE SÛRETÉ POUR LES MACHINES À SOUDER À TRANSFORMATEUR ET À REDRESSEUR

1. Relier à la terre le châssis du poste conformément au code de l'électricité et aux recommandations du fabricant. Le dispositif de montage ou la pièce à souder doit être branché à une bonne mise à la terre.
2. Autant que possible, l'installation et l'entretien du poste seront effectués par un électricien qualifié.
3. Avant de faire des travaux à l'intérieur de poste, la débrancher à l'interrupteur à la boîte de fusibles.
4. Garder tous les couvercles et dispositifs de sûreté à leur place.

Thank You

for selecting a **QUALITY** product by Lincoln Electric. We want you to take pride in operating this Lincoln Electric Company product
 ••• as much pride as we have in bringing this product to you!

CUSTOMER ASSISTANCE POLICY

The business of The Lincoln Electric Company is manufacturing and selling high quality welding equipment, consumables, and cutting equipment. Our challenge is to meet the needs of our customers and to exceed their expectations. On occasion, purchasers may ask Lincoln Electric for advice or information about their use of our products. We respond to our customers based on the best information in our possession at that time. Lincoln Electric is not in a position to warrant or guarantee such advice, and assumes no liability, with respect to such information or advice. We expressly disclaim any warranty of any kind, including any warranty of fitness for any customer's particular purpose, with respect to such information or advice. As a matter of practical consideration, we also cannot assume any responsibility for updating or correcting any such information or advice once it has been given, nor does the provision of information or advice create, expand or alter any warranty with respect to the sale of our products.

Lincoln Electric is a responsive manufacturer, but the selection and use of specific products sold by Lincoln Electric is solely within the control of, and remains the sole responsibility of the customer. Many variables beyond the control of Lincoln Electric affect the results obtained in applying these types of fabrication methods and service requirements.

Subject to Change – This information is accurate to the best of our knowledge at the time of printing. Please refer to www.lincolnelectric.com for any updated information.

Please Examine Carton and Equipment For Damage Immediately

When this equipment is shipped, title passes to the purchaser upon receipt by the carrier. Consequently, Claims for material damaged in shipment must be made by the purchaser against the transportation company at the time the shipment is received.

Please record your equipment identification information below for future reference. This information can be found on your machine nameplate.

Product _____

Model Number _____

Code Number or Date Code _____

Serial Number _____

Date Purchased _____

Where Purchased _____

Whenever you request replacement parts or information on this equipment, always supply the information you have recorded above. The code number is especially important when identifying the correct replacement parts.

On-Line Product Registration

- Register your machine with Lincoln Electric either via fax or over the Internet.
 - For faxing: Complete the form on the back of the warranty statement included in the literature packet accompanying this machine and fax the form per the instructions printed on it.
 - For On-Line Registration: Go to our **WEB SITE at www.lincolnelectric.com**. Choose "Quick Links" and then "Product Registration". Please complete the form and submit your registration.

Read this Operators Manual completely before attempting to use this equipment. Save this manual and keep it handy for quick reference. Pay particular attention to the safety instructions we have provided for your protection. The level of seriousness to be applied to each is explained below:

⚠ WARNING

This statement appears where the information **must** be followed **exactly** to avoid **serious personal injury or loss of life**.

⚠ CAUTION

This statement appears where the information **must** be followed to avoid **minor personal injury or damage to this equipment**.

Installation	Section A
Technical Specifications.....	A-1
Safety Precautions.....	A-2
Welding Voltage, Mechanical Hazards.....	A-2
Location and Mounting.....	A-2
High Frequency Protection.....	A-2
Auxiliary Equipment Input Power Connection.....	A-2
Interfacing to the POWER FEED™ 10A CONTROLLER.....	A-3 thru A-4
Controlling Non-Lincoln Auxilliary Equipment.....	A-5 thru A-6
Connection Diagram System.....	A-7
Remote Sense Lead Specification.....	A-8
Operation	Section B
Safety Precautions.....	B-1
Design Features.....	B-1
Definitions of Welding Modes.....	B-1
Common Welding Abbreviations.....	B-1
Product Description.....	B-2
Recommended Processes.....	B-2
Locating Front Panel Controls and Input, Output Connections.....	B-3
Case Front Controls and Description.....	B-4 thru B5
Power-Up Sequence.....	B-5
Inch Wire Feed Speed Settings.....	B-5
Changing Weld Modes.....	B-6
Mode Select Panel 4 (MSP4).....	B-6
Weld Mode Description.....	B-6
AC Control.....	B-7
Start Options.....	B-7
End Options.....	B-8
Weld Sequence Parameter List.....	B-9
General Setup Mode Options.....	B-10
Infrared (IR) Control.....	B-11
Lockout/Security.....	B-11
Memory Panel Description.....	B-12
Limit Setting.....	B-13
Accessories	Section C
General Options / Accessories.....	C-1
Maintenance	Section D
Safety Precautions.....	D-1
Routine.....	D-1
Periodic.....	D-1
Calibration Specification.....	D-1
Troubleshooting	Section E
Safety Precautions.....	E-1
How to Use Troubleshooting Guide.....	E-1
Troubleshooting Guide.....	E-2 thru E-6
Wiring Diagram and Dimension Print	Section F
Parts Lists	P-506

TECHNICAL SPECIFICATIONS: POWER FEED™ 10A CONTROLLER

SPEC.#		TYPE	142:1 SPEED RATIO			95:1 SPEED RATIO		
Cored		POWER FEED™ 10A CONTROLLER	Wire Size			Cored	Wire Size	
			Speed	Solid			Speed	Solid
with Power Feed 10SF								
K2362-1		10-200 IPM (0.25 -5.08 m/min.)	7/32 in. (5.6 mm)	5/32 in. (4.0 mm)	10-300 ipm (0.25 -7.62 m/min.)	1/8 in. (3.2 mm)	5/32 in. (4.0 mm)	

INPUT VOLTAGE & CURRENT			PHYSICAL SIZE•			TEMPERATURE RATING		
Model	Voltage*	Input Amps*	Dimensions			Weight	Operating	Storage
			Height	Width	Depth			
K2362-1	40VDC	1.0	15.0in. (381 mm)	13.0 in (259 mm)	4.0 in. (102 mm)	25 Lbs (11.3 Kg.)	4°F to 104°F (-20°C to 40°C)	-40°F to 185°F (-40°C to 85°C)

* When not driving a motor.

WELDING PROCESSES			
Process	Electrode Diameter Range	Output Range (Amperes)	Wire Feed Speed Range
SAW	5/64 in. – 7/32 in (2.0 – 5.6 mm)	1000 Amps	10 - 300 ipm (0.254- 7.62 m/minute)

POWER FEED™ 10A CONTROLLER



SAFETY PRECAUTION

⚠ WARNING



ELECTRIC SHOCK can kill.

- Only a qualified electrician should connect the POWER FEED™ 10A CONTROLLER. Installation should be made in accordance with the appropriate National Electrical Code, the local codes and the information in this manual.
- Turn off the input power to the power source at the disconnect switch or fuse box before working on this equipment. Turn off the input power to any other equipment connected to the welding system at the disconnect switch or fuse box before working on this equipment.

- Do not touch electrically hot parts.

WELDING VOLTAGE

Wire feed parts are electrically live while welding and while inching wire (with Touch Sense feature selection). The electrically live parts are listed below:

Electrode	Electrode Reel
Wire Drive Motor	Drive Rolls
Gear Box	Cross-seam Adjuster
Wire Straightener	Welding Nozzle
Welding Cables	Welding Cable Terminal

⚠ CAUTION



- Do not touch electrically live parts or electrodes with your skin or wet clothing.
- Insulate yourself from the work and ground.
- Always wear dry insulating gloves.

MECHANICAL HAZARDS

- Welding fixture or wire feeder will move during welding or inching. Keep away from pinch points.
- Electrode reel and drive rolls turn during welding or inching. Keep gloved hands away from areas that may catch the glove.



LOCATION AND MOUNTING

The POWER FEED™ 10A CONTROLLER will operate in harsh environments. Even so, it is important that simple preventative measures are followed in order to assure long life and reliable operation. The POWER FEED™ 10A CONTROLLER must be located where there is little risk of impacts to the Controller.

HIGH FREQUENCY PROTECTION

Locate the POWER FEED™ 10A CONTROLLER away from radio controlled machinery. The normal operation of the POWER FEED™ 10A CONTROLLER may adversely affect the operation of RF controlled equipment, which may result in bodily injury or damage to the equipment.

AUXILIARY EQUIPMENT INPUT POWER CONNECTION

The POWER FEED™ 10A CONTROLLER has the ability to control auxiliary equipment such as flux hoppers and travel motors using solid state relays. There are three relays in the POWER FEED™ 10A CONTROLLER, controlled by two independent coil drivers. The coils of CR1 and CR2 are in parallel, therefore, they must turn ON and OFF at the same time. The CR1 and CR2 relays are designated for driving travel motors to control motion. CR3 is driven separately, and is designated to control flux hopper operation.

POWER FEED™ 10A CONTROLLER Relay Ratings:

Coil: 12Vdc, resistance = 86 ohms at 25° C

N.C. Contacts: 3A @ 277Vac

N.O. Contacts: 30A @ 277Vac

The POWER FEED™ 10A CONTROLLER does not provide the input power to feed auxiliary equipment, therefore a separate power feed must be provided by the end user. The POWER FEED™ 10A CONTROLLER has been shipped standard with all of the wiring and connectivity to connect to the Lincoln K325 TC-3 Travel Carriage (4-pin cable connector) and the Lincoln K219 Automatic Flux Hopper (3-pin cable connector). The CR2 Relay is wired to the 4-pin travel connector, and the CR3 Relay is wired to the 3-pin flux connector, both located on the bottom of the POWER FEED™ 10A CONTROLLER. 115Vac, 50/60Hz power is required for the Lincoln auxiliary equipment.

If either of these is to be used with the POWER FEED™ 10A CONTROLLER, the end-user must provide the 115Vac input power to the terminal strip located inside the POWER FEED™ 10A CONTROLLER. Access to the terminal strip may be obtained via the 4 access holes in the bottom of the POWER FEED™ 10A CONTROLLER. These access holes are shipped with plug buttons installed.

⚠ WARNING

Although input power to POWER FEED™ 10A CONTROLLER is turned off, the customer installed auxiliary input may be energized! Ensure that all input power to the POWER FEED™ 10A CONTROLLER is turned off before opening the cover.

Auxiliary Input Power Connection Instructions:

1. Remove two Phillips Head screws on right side of front panel of hinged door to access terminal strip.
2. Remove a plug button and install a box connector to provide strain relief for the input power leads.
3. Use the appropriate size leads, at least 14 AWG – 2 wire with ground.
4. Using a flat-head screwdriver with a blade dimension of 0.137"(3.5mm) x 0.020"(.51mm), insert the screwdriver into the square hole next to the mounting hole to be used on the terminal strip. The screwdriver should be inserted until it bottoms out. This opens the screwless cage clamping style wire insertion port. The insulation on the leads should be stripped at least 0.25"(6.4mm). With the cage clamp opened insert the wire into the round port until it bottoms out. While holding the lead securely, remove the screwdriver from the terminal block. This closes the cage clamp onto the lead holding it securely. Any open port on blocks #48, #49, and #50 may be used.
5. The 4-terminal blocks, numbered #48, #49, and #50 are to be used to bring in auxiliary power. Terminal block #50 is used for the input ground connection. This terminal block is color-coded green and yellow for easy identification. Terminal blocks #48 and #49 are to be used to connect the input power circuit. (See figure A.1)

Terminal blocks 48 and 49 are shipped connected to CR2 and CR3 (532 and 531 leads) and these relays are connected to the 3-pin and 4-pin connectors located on the bottom of the POWER FEED™ 10A CONTROLLER. CR1 is available for a separate customer connection, but it will turn ON and OFF with CR2. Therefore, if Lincoln auxiliary equipment is to be used, connecting 115Vac to the terminal strip is all that is required to power the devices.

NOTE: The contacts of CR1 are not connected to terminals #48 and #49 when shipped. Applying power the #48 and #49 terminals will not transfer voltage to the CR1 relay. Connect leads from the #48 terminal to the #4 terminal and from the #49 terminal to the #3 terminal to supply power to the common contacts of the relay.

Once input power is applied to the terminal strip, this voltage is always on terminal strip blocks #3, #4 (if connected), #11, #17, and #18. These are the inputs to the solid-state relay contacts. Input voltage is also present on terminal strip blocks #7, #8 (if connected), #15, #21, and #22 due to the N.C. contacts on the relays. When the CR1 relay is energized, input power is transferred to terminal strip blocks #5 and #6 (if connected). When the CR2 relay is energized, input power is transferred to terminal strip block #13. When the CR3 relay is energized, input power is transferred to terminal strip blocks #19 and #20. CR1 and CR2 will be turned ON and OFF at the same time.

INTERFACING TO THE POWER FEED™ 10A CONTROLLER

The POWER FEED™ 10A CONTROLLER is a versatile controller. The Switch Panel can be removed and made into a hand-held pendant. Most circuits can be accessed through the screwless terminal strip. The auxiliary relays can control standard Lincoln equipment, or they can be used to control any other auxiliary equipment (see relay rating information above). Custom controls or PLC interfacing to control starting, stopping, motion, etc. can be accomplished with ease.

Converting Switch Panel to a remote pendant:

1. Remove all input power to the POWER FEED™ 10A CONTROLLER including any auxiliary power supplies.
2. Remove the fasteners from the Switch Panel and disconnect the Switch Panel from the wire harness.
3. Jumper the wire harness connector (J2) to the mating 10-pin connector (P2P) that is floating inside the control box (See Wiring Diagram).

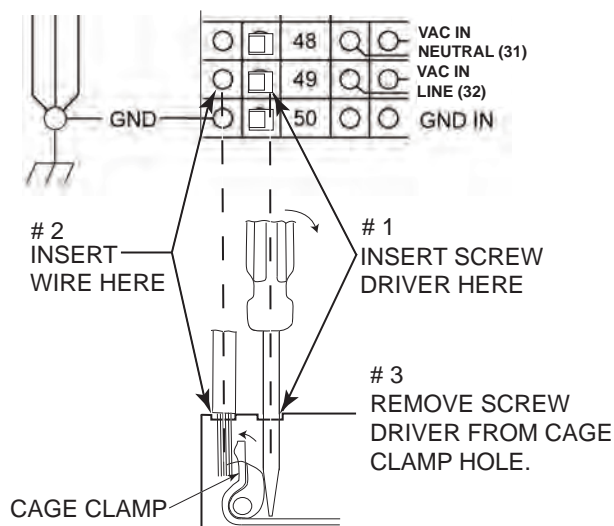
FIGURE A.1**POWER FEED™ 10A CONTROLLER**

4. Replace the Switch Panel on the POWER FEED™ 10A CONTROLLER with the blank panel included with the pendant box.
5. Connect the Switch Panel to the mating 10-pin connector inside the pendant box.
6. Fasten the Switch Panel to the pendant box.
7. Connect the 14-pin/9-pin pendant cable to the mating cable connector on the bottom of the POWER FEED™ 10A CONTROLLER and the mating cable connector on the pendant.
8. The remote pendant is now ready to be used.
7. Remove one of the plug buttons located on the bottom of the POWER FEED™ 10A CONTROLLER control box and install some type of strain relief for the interfacing leads.
8. Connect the interfacing leads to the Switch Panel circuits on the terminal strip (see Wiring Diagram for terminal strip designations). The supply for START, STOP, and INCH UP comes from SWITCH GROUP #1 SUPPLY on block #39. The supply for TRAVEL AUTO, TRAVEL ON, FLUX FILL, and INCH DOWN comes from SWITCH GROUP #2 SUPPLY on block #43.
9. To activate any of the Switch Panel circuits, a contact closure must be established between the supply and the particular circuit it is referenced to – for instance, to start the weld sequence, a contact closure must be established momentarily between terminal strip blocks #39 (SUPPLY) and #40 (START). See FIGURE A.2.
10. The leads from the 14-pin connector that were removed from the terminal strip can be taped and secured in the wire duct located next to the terminal strip.

Interfacing to the Switch Panel Controls:

The Switch Panel circuits can be accessed on the screwless terminal strip. Easy access to these circuits enables the POWER FEED™ 10A CONTROLLER to interface with custom controls or PLC's. These circuits must see a contact closure to function properly.

1. Remove all input power to the POWER FEED™ 10A CONTROLLER including any auxiliary power supplies.
2. Remove the fasteners from the Switch Panel and disconnect the Switch Panel from the wire harness. The Switch Panel should be stored in a secure

CAUTION

place in the event that it is needed in the future.

The Switch Panel should not be left in the POWER FEED™ 10A CONTROLLER if the switches are not connected. This could cause a safety concern due to the fact that the switches will not stop the welding sequence, etc.

3. Jumper the wire harness connector (J2) to the mating 10-pin connector (P2P) that is floating inside the control box (See Wiring Diagram).
4. Replace the Switch Panel on the POWER FEED™ 10A CONTROLLER with the blank panel included with the pendant box.
5. Remove the wire duct cover to gain access to the leads on the right side of the terminal strip.
6. Remove the leads going to the Pendant 14-pin connector from the right side of terminal strip blocks #39, #40, #41, #42, #43, #44, #45, #46, & #47. (Note – see Auxiliary Input Power Connection Instructions on how to remove/install wires to the screwless terminal strip)

FIGURE A.2

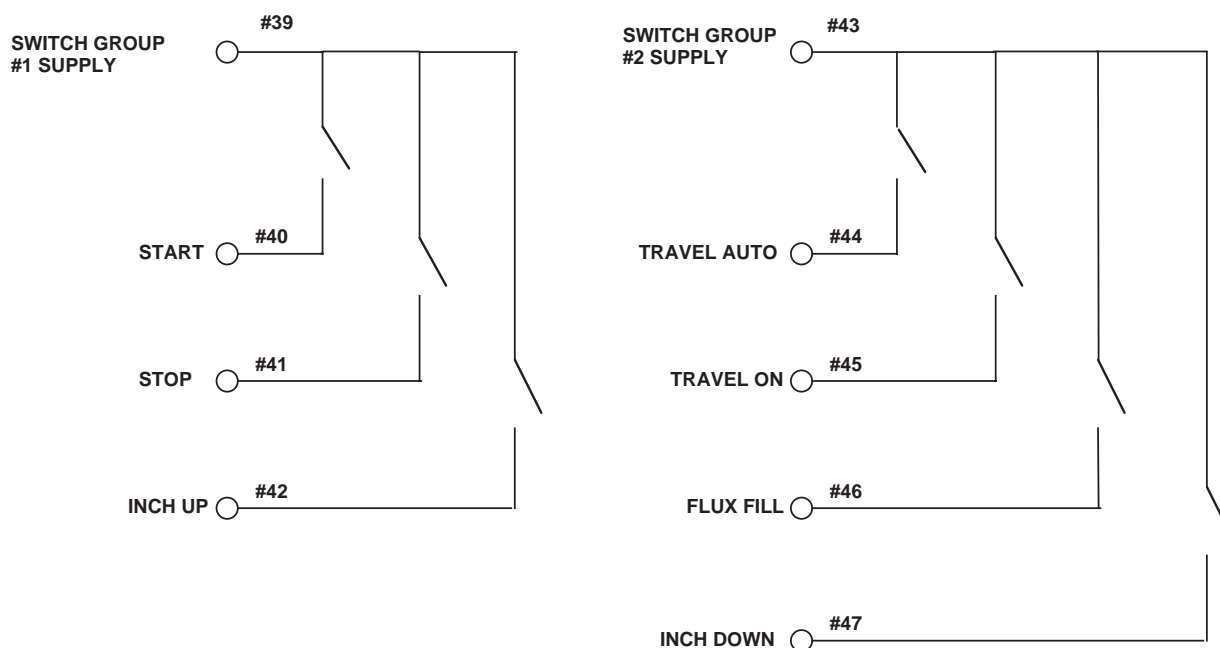

NOTE: TRAVEL AUTO and TRAVEL ON should not be closed at the same time. Either one OR the other should be closed at any time, and must remain closed to keep particular Travel Mode active. If neither switch is closed at any time, travel will be turned OFF, regardless of the welding state. Inching and Flux switches will activate their particular function when the switch is closed, and will cease when opened. The START and STOP switches are MOMENTARY and only need to be closed for a short period of time to start or stop the weld sequence.

CONTROLLING NON-LINCOLN AUXILIARY EQUIPMENT:

Custom motion control and/or other auxiliary equipment can be powered using the terminal strip and relays. To use non-Lincoln motion control and/or flux hoppers, follow instructions below.

1. Remove all input power to the POWER FEED™ 10A CONTROLLER including any auxiliary power supplies.
2. Remove the wire duct cover to gain access to the leads on the right side of the terminal strip.
3. Remove one of the plug buttons located on the bottom of the POWER FEED™ 10A CONTROLLER control box and install some type of strain relief for the auxiliary control leads.
4. Remove the leads going from the terminal strip to the corresponding connectors, i.e. terminal strip blocks #11, #13, and #16 for the 4-pin TC-3 Travel Carriage or terminal strip blocks #19, #20, and #23 for the 3-pin Automatic Flux Hopper.
5. These loose leads can be taped and secured in the wire duct.
6. Any custom or non-Lincoln equipment can be powered by the normally open contacts from relays CR1, CR2, or CR3. The normally open contacts for CR1 are located on terminal strip blocks #5 and #6. The normally open contacts for CR2 are located on terminal strip blocks #12 and #13. The normally open contacts for CR3 are located on terminal strip blocks #19 and #20. CR1 and CR2 are BOTH turned ON when the weld sequence starts and are BOTH turned OFF when the weld sequence stops as long as the TRAVEL MODE Switch is in the AUTO position.
7. The input supply voltage to power these devices is provided by the end user. As shipped, the PF-10A has the auxiliary supply blocks (terminal strip blocks #48 and #49) connected to the CR2 relay and CR3 relay inputs, respectively. When the end user connects a supply to the AUX blocks #48 and #49, this voltage will be jumpered to the CR2 and CR3 relay inputs on terminal strip blocks #11, #17, and #18. Note – the CR1 relay is not connected to the AUX terminal strip blocks; the customer must connect power to this relay if it is to be used. See relay ratings listed earlier.

POWER FEED™ 10A CONTROLLER



8. Connect input supply voltage per the Auxiliary Input Power Connection Instructions listed earlier.
9. The relays could also be used to provide contact closure for any interfacing signals out using the normally open contacts. An external auxiliary supply voltage would not be necessary to use the relays as hard contact closure out signals. NOTE - The CR1 relay as shipped does not have AUX leads connected to it. This relay has two normally open contacts that close at the start of the weld cycle and open at the end of the weld cycle. These hard contact closures could be used as a signal out when interfacing to PLC's or custom controls.

Shutdown Inputs:

The POWER FEED™ 10A CONTROLLER has two shutdown inputs available on the terminal strip. These are independent, normally closed inputs that can be used for limit switches, PLC inputs, etc, in order to shut down the welding operation for any reason. Shutdown #1 is located on terminal strip blocks #24 and #25. Shutdown #2 is located on terminal strip blocks #26 and #27.

1. Remove all input power to the POWER FEED™ 10A CONTROLLER including any auxiliary power supplies.
2. Remove the wire duct cover to gain access to the leads on the right side of the terminal strip.
3. Remove one of the plug buttons located on the bottom of the POWER FEED™ 10A CONTROLLER control box and install some type of strain relief for the auxiliary control leads.
4. Connect the external shutdown circuit to either of the shutdown terminal blocks, #24 & #25, and/or #26 & #27. A normally closed circuit must be connected – the POWER FEED™ 10A CONTROLLER will recognize an open circuit as a shutdown command.
5. Remove the shorting jumpers imbedded in the center of the terminal strip with a small screwdriver for the shutdown circuits to be used.

When a shutdown input is received, all welding will stop and an error message will be displayed on the POWER FEED™ 10A CONTROLLER. The shutdown circuit must be closed before resetting Controller. To reset the system, the Mode Select Panel display will prompt the user to press the left Mode Select Panel Pushbutton.

Shutdown #2 can be configured for Output Lockout mode by enabling option P.21 in the Setup Menu (Refer to Section B, General Setup Mode Options). when the input is opened, output is disabled, but cold feed of wire is still possible.

Stop Input:

The POWER FEED™ 10A CONTROLLER has a Stop Input available on the terminal strip. The Stop Input will work just like pressing the STOP Pushbutton. This circuit is in parallel with the STOP Pushbutton located on the Switch Panel. Unlike the Shutdown Inputs, which completely shutdown all welding and auxiliary equipment, the STOP Input will allow all welding and auxiliary motion to continue based on the END OPTIONS configurations in the POWER FEED™ 10A CONTROLLER.

1. Remove all input power to the POWER FEED™ 10A CONTROLLER including any auxiliary power supplies.
2. Remove the wire duct cover to gain access to the leads on the right side of the terminal strip.
3. Remove one of the plug buttons located on the bottom of the POWER FEED™ 10A CONTROLLER control box and install some type of strain relief for the auxiliary control leads.
4. Connect the external Stop Input circuit to terminal blocks #28 and #29.

The Stop Input is not necessary if the POWER FEED™ 10A CONTROLLER is configured for Remote Interfacing, mentioned earlier, due to the fact that the Stop circuit can be accessed, in this configuration, on terminal strip blocks #39 and #41. The Stop Input was intended to be used when the Switch Panel is still included in the system, either on the Controller, or in the Pendant.

Note: the STOP circuit only needs a momentary closure to be recognized by the POWER FEED™ 10A CONTROLLER. If the STOP button is held, the START and INCH buttons are not recognized.

CONNECTION DIAGRAM SYSTEM

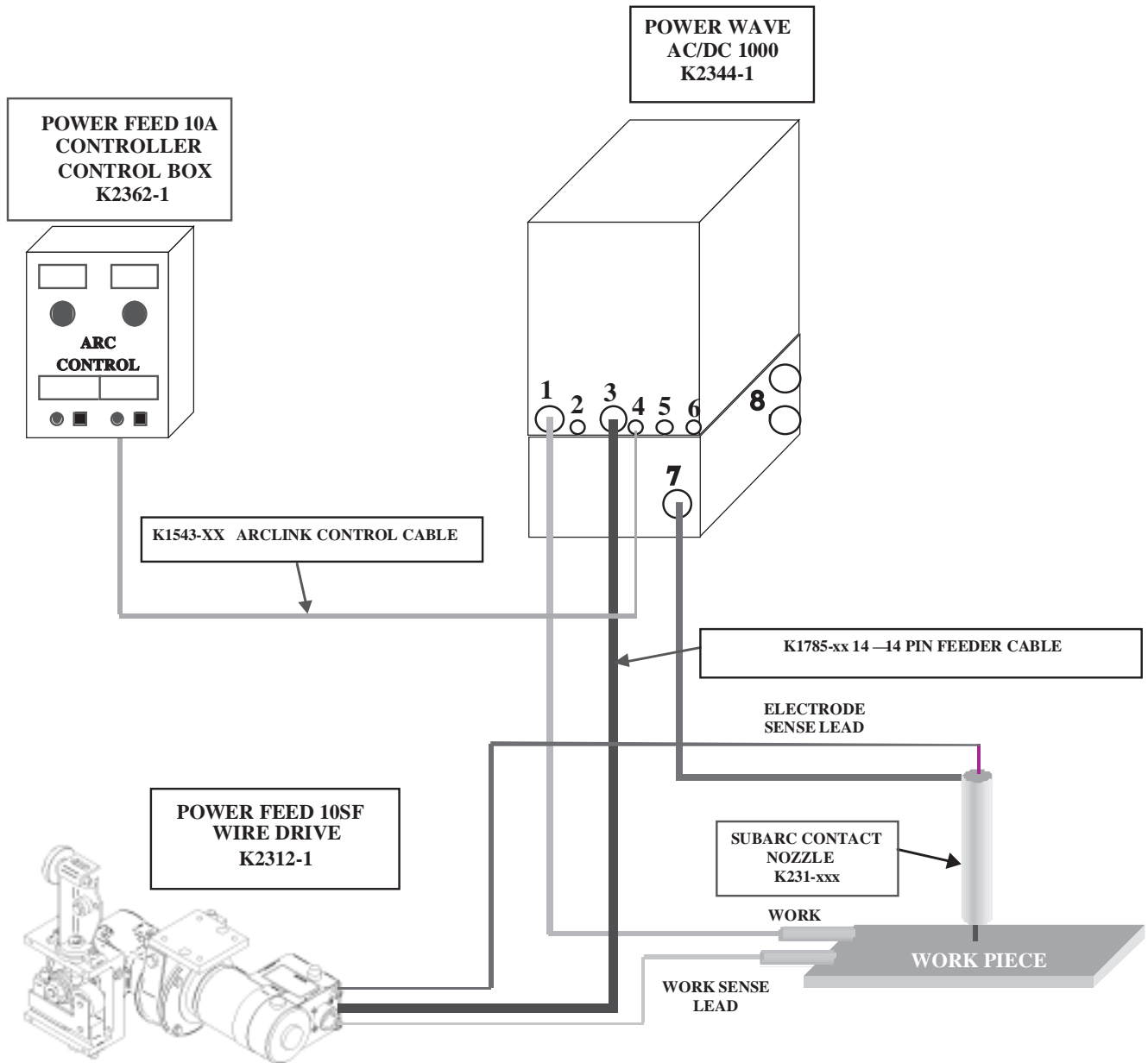

REMOTE SENSE LEAD SPECIFICATIONS

Welding with Multiple Arcs

Special care must be taken when more than one arc is welding simultaneously on a single part. Arc blow and arc interference may occur or be magnified. Each power source requires a work lead from the work stud to the welding fixture. Do not combine all of the work leads into one lead. Perform welding in the direction away from the work leads. Connect all of the work sense leads from each power source to the work piece at the end of the weld, such that they are out of the path of the weld current.

For the best results when pulse welding, set the wire size and wire feed speed the same for all the arcs. When these parameters are identical, the pulsing frequency will be the same, helping to stabilize the arcs.

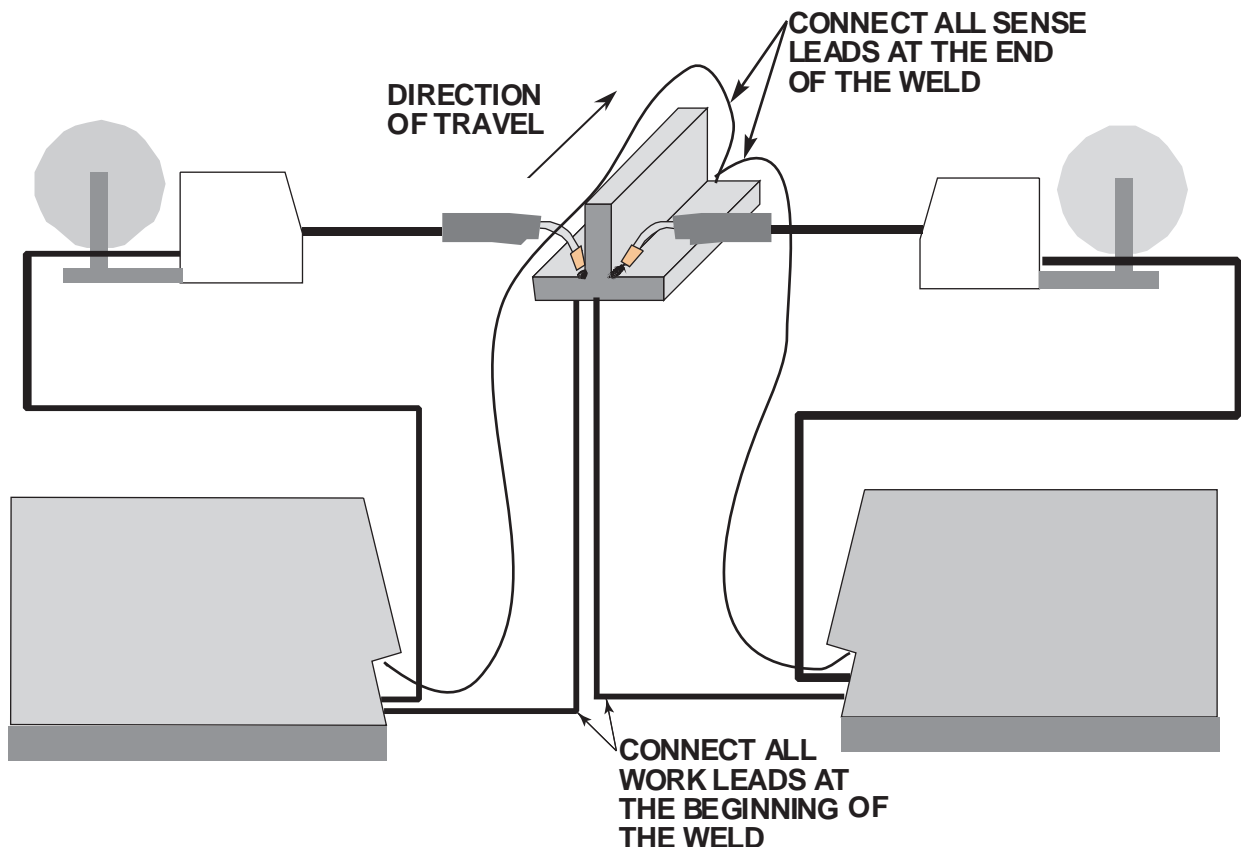

POWER FEED™ 10A CONTROLLER



SAFETY PRECAUTIONS

Read this entire section of operating instructions before operating the machine.



WARNING



ELECTRIC SHOCK can kill.

- Do not touch electrically live parts or electrodes with your skin or wet clothing.
 - Insulate yourself from the work and ground.
 - Always wear dry insulating gloves.
 - Do not use AC welder if your clothing, gloves or work area is damp or if working on, under or inside work-piece.
- Use the following equipment:
- DC manual (stick) welder.
 - AC welder with reduced voltage control.
- Do not operate with panels removed.
 - Disconnect input power before servicing.



ONLY QUALIFIED PERSONS SHOULD INSTALL, USE OR SERVICE THIS EQUIPMENT. READ AND FOLLOW THE MANUFACTURER'S INSTRUCTIONS, EMPLOYER'S SAFETY PRACTICES AND MATERIAL SAFETY DATA SHEETS (MSDS) FOR CONSUMABLES.

READ THIS WARNING, PROTECT YOURSELF & OTHERS.



FUMES AND GASES can be dangerous.

- Keep your head out of fumes.
- Use ventilation or exhaust at the arc, or both, to keep fumes and gases from your breathing zone and general area.



WELDING SPARKS can cause fire or explosion.

- Do not weld near flammable material.
- Do not weld on containers which have held flammable material.



ARC RAYS can burn.

- Wear eye, ear, and body protection.

DESIGN FEATURES

- Mode Select Panel for easy control of all weld parameters.
- Memory Panel for easy storage and recall of weld schedules.
- Weld parameter limit setting and lockout capabilities.
- Digital communications for accurate and reliable performance.
- Infrared red (IR) port for transferring weld settings.
- PC boards are potted in epoxy for the ultimate in outdoor protection.
- Connectors are filled with environmental protective grease.
- Designed for the Power Wave series of products for the best arc in the industry.
- Wire feed speed accuracy calibrated to within 2%.
- Digital display of voltage and wire feed speed.
- Tachometer controlled wire drive motor.
- Flux Fill Switch.
- Bright, high intensity digital read-outs.
- Industrial Push Button Switches
- Switch panel can be removed and remoted into a pendant.

DEFINITIONS OF WELDING MODES

NON-SYNERGIC WELDING MODES

- A **Non-synergic** welding mode requires all welding process variables to be set by the operator.

SYNERGIC WELDING MODES

- A **Synergic** welding mode offers the simplicity of single knob control. The machine will select the correct voltage and amperage based on the wire feed speed (WFS) set by the operator.

COMMON WELDING ABBREVIATIONS

SAW

- Submerged Arc Welding

PRODUCT DESCRIPTION

General Physical Description

The POWER FEED™ 10A CONTROLLER is a user interface. The control is used to set all welding parameters and control any travel mechanisms. High-speed digital cables connect the control, wire drive, and the Power Wave power source together.

The POWER FEED™ 10A CONTROLLER is a self-contained control box designed to control the entire weld cell at one location. The control uses bright digital displays, encoders, and heavy-duty pushbuttons designed for every-day industrial use.

The Mode Select Panel utilizes alphanumeric displays for advanced text messaging providing the end user with an intuitive interface allowing for easy set up and real-time control of all welding parameters.

A six button Memory Panel has been included which provides easy storage and recall of stored welding parameters.

The Switch Panel can be removed from the control box and turned into a Pendant for remote control near the arc.

General Functional Description

- The POWER FEED™ 10A CONTROLLER is one of the most versatile user interfaces ever created. Easy to use features make it a snap to adjust the arc for specific preferences.
- The new Mode Select Panel brightly displays essential welding information. Use the Mode Select Panel to quickly adjust weld settings, arc starting parameters, arc end parameters and set-up information.
- The Memory Panel allows for up to six weld schedules to be stored and quickly recalled. The Memory Panel along with the Mode Select Panel allows for multiple levels of limits and lockouts.
- Digital communications to the power source provide the most accurate and reliable operation possible.
- The POWER FEED™ 10A CONTROLLER is one of the first user interfaces with an infrared red (IR) port. Transferring weld settings from one user interface to another is accomplished with a common Palm computer.

- When the POWER FEED™ 10A CONTROLLER is coupled to a Power Wave welding power source, the result is a welding system with the best arc performance on the market.

RECOMMENDED PROCESSES

- The POWER FEED™ 10A CONTROLLER is best suited for submerged arc welding.
- SAW

PROCESS LIMITATIONS

- MIG processes

The Mode Select Panel does not support "Spot" welding.

Not all weld modes or processes described in this manual are available on all Power Wave power sources.

EQUIPMENT LIMITATIONS

- The POWER FEED™ 10A CONTROLLER does not operate with the Power Wave 450.
- The POWER FEED™ 10A CONTROLLER does not operate with any analog-based power sources (CV-xxx machines, DC-xxx machines, etc.)

COMMON BASIC EQUIPMENT PACKAGES

Basic Packages:

Power Wave 1000 AC/DC

Power Feed-10SF Wire Drive

Basic Optional Kits:

Power Feed-10SM Motor Conversion Kit
(Converts Lincoln NA style wire drives)

Power Feed-10S Wire Drive (connects to
Lincoln TC-3 Travel Carriage)

System Interface (Phase Generator)

LOCATING FRONT PANEL CONTROLS AND INPUT, OUTPUT CONNECTIONS

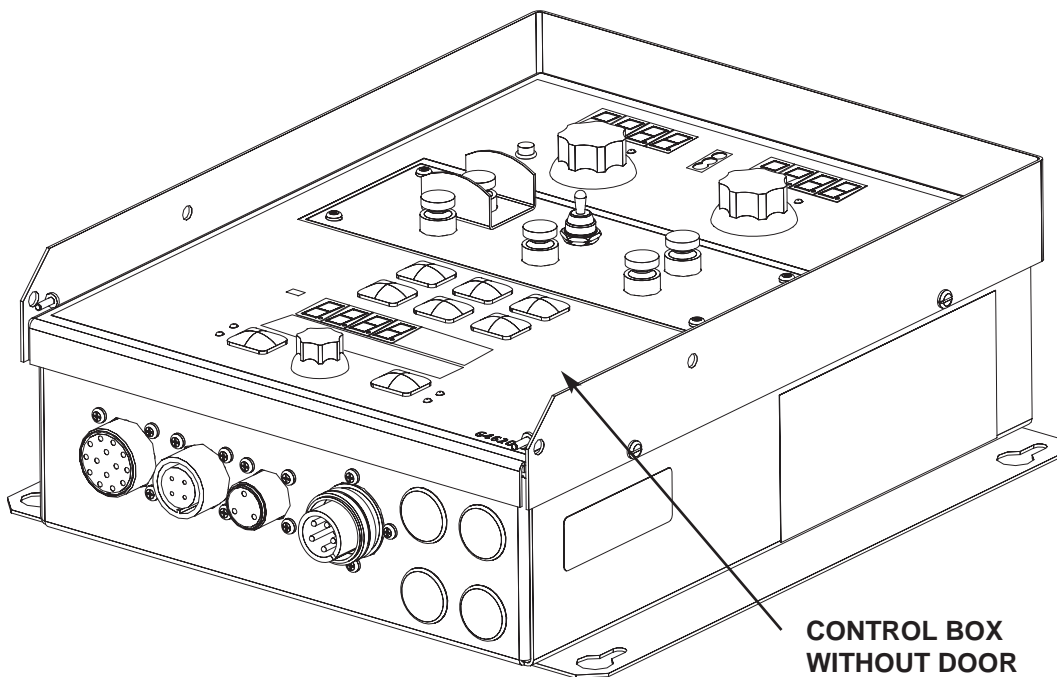
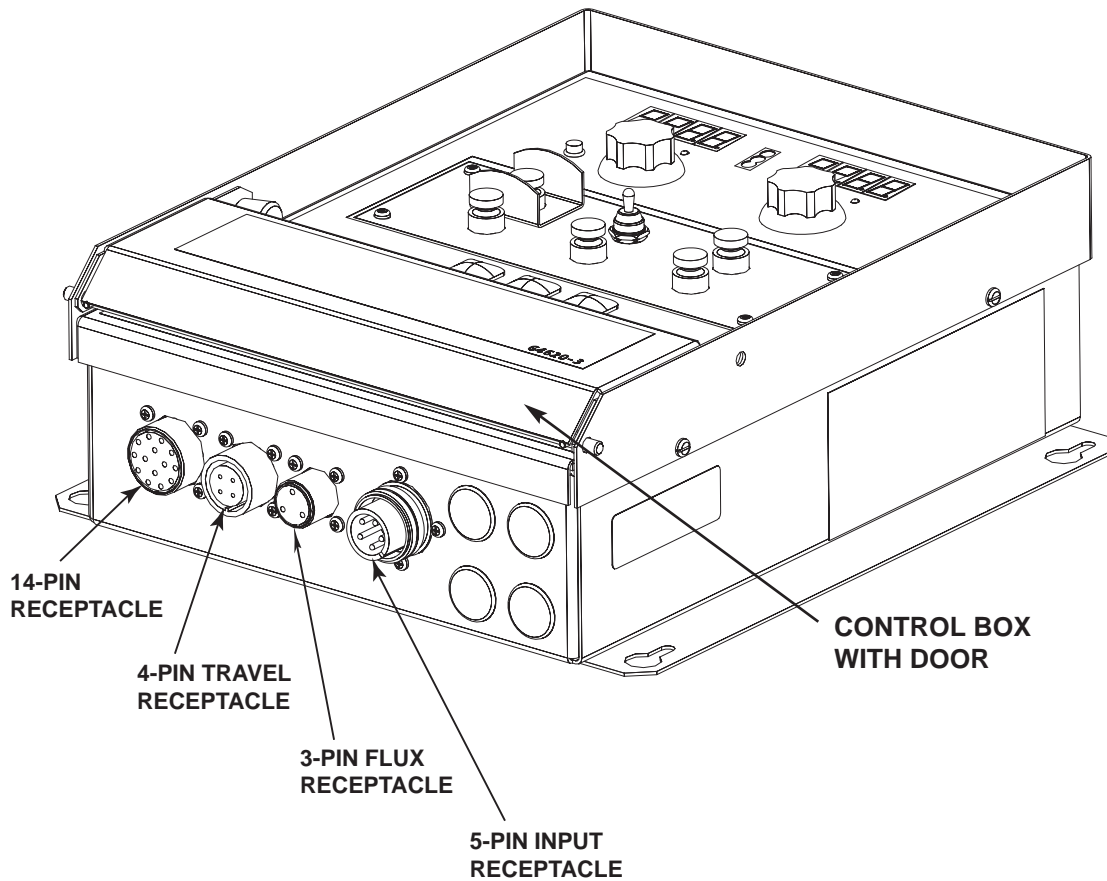

POWER FEED™ 10A CONTROLLER



CASE FRONT CONTROLS

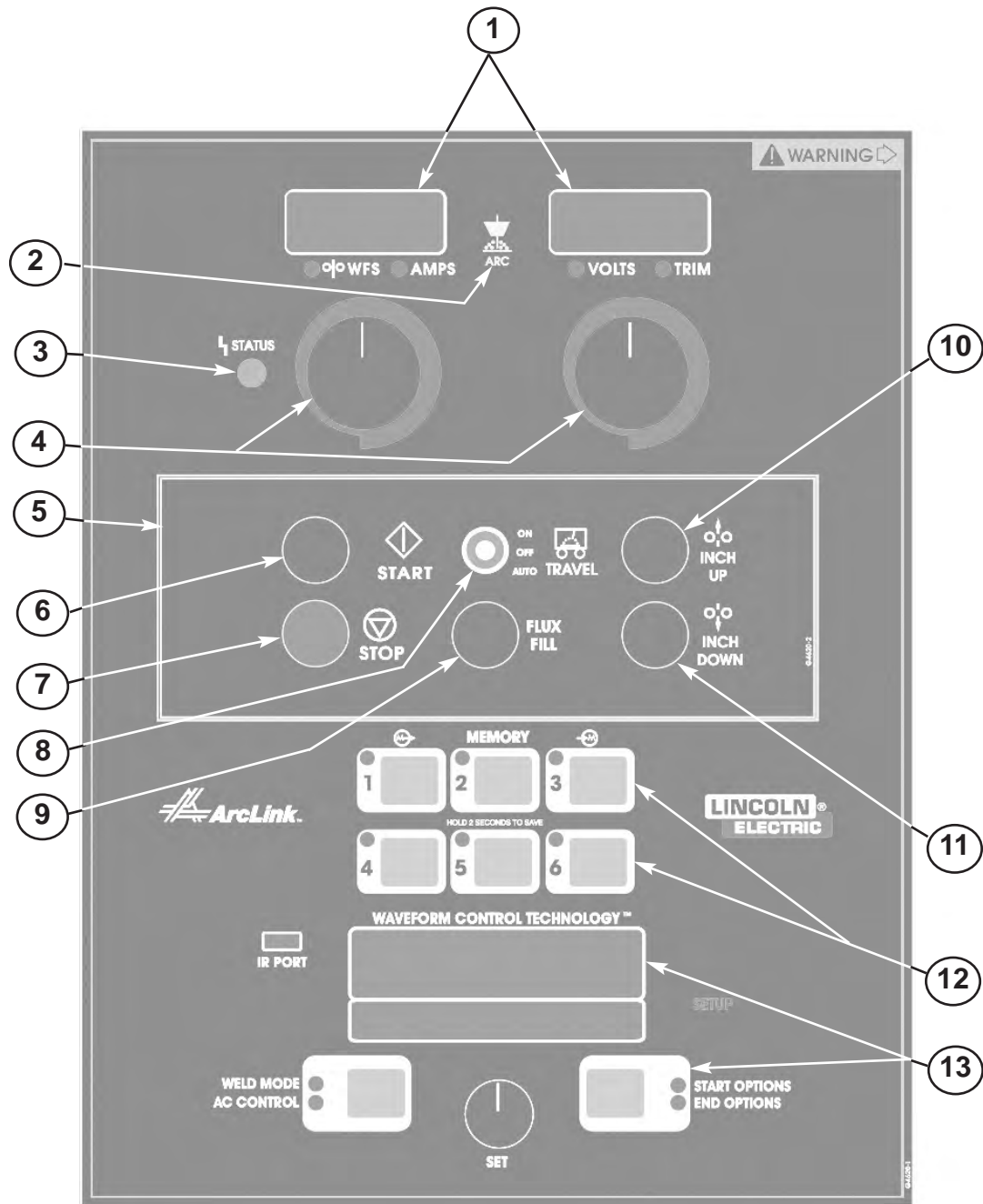

CASE FRONT CONTROL DESCRIPTIONS

- 1. **DUAL DIGITAL DISPLAYS** – Bright 7-segment displays showing welding parameter settings and actual levels while welding.
- 2. **ARC ESTABLISH INDICATOR** – Illuminates when a "true" arc has been established. (Flashes when open circuit voltage is applied. Not available on all units, upgrade software to include this feature.

- 3. **Status LED** - The status LED indicates system status. Normal operation is a steady green light.
Note: During normal power-up, the LED may flash red and/or green as the equipment performs self tests.

LED condition	Definition
Steady green	System okay. The power source and wire feeder are communicating normally.

Blinking green	Occurs during a reset and indicates the power source is identifying each component in the system. This is normal for the first 10 seconds after power-up, or if the system configuration is changed during operation.
Alternating green and red	<p>Non-recoverable system fault. If the power source or wire feeder status LED is flashing any combination of red and green, errors are present in the system. Read the error code before the machine is turned off.</p> <p>Instructions for reading the error code are detailed in the Service Manual. Individual code digits are flashed in red with a long pause between digits. If more than one code is present, the codes will be separated by a green light.</p> <p>To clear the error, turn the power source OFF, and then back ON to reset. See troubleshooting section.</p>
Steady red	Non recoverable hardware fault. Generally indicates a problem with the cables connecting the wire feeder to the power source.
Blinking red	Not applicable.

4. **DUAL ENCODERS** – Accurately adjust weld parameters as pre-set values, or on-the-fly values while welding.
5. **SWITCH PANEL** – Heavy-duty pushbutton switches that control inching of the wire, starting and stopping of welding, travel and flux control. The Switch Panel can be removed and turned into a remote pendant.
6. **START** – Activates the weld cycle.
7. **STOP** – Deactivates the weld cycle.
8. **TRAVEL MODE:**
 - ON – Activates travel.
 - OFF – Disables travel.
 - AUTO – Activates travel when the START button is pressed. Disables travel when the STOP button is pressed.
9. **FLUX FILL** – Activates the flux hopper.
10. **INCH UP** – Feeds the wire upwards, away from the work.

11. **INCH DOWN** – Feeds the wire downward, toward the work. NOTE: The Power Feed 10A includes an option in the Setup Menu (P.15) to enable the touch sense circuitry in the power source. Having this feature enabled will stop the wire when it comes in contact with the work, engaging the flux hopper on contact for automatic flux fill. The flux hopper will disengage when the INCH DOWN button is released.

⚠ WARNING

- This “Hot Inch” feature enables the output. Avoid touching any exposed parts as defined in the “Installation Section A-2”.

12. **MEMORY PANEL** – Enables the storage and recall of up to 6 weld schedules. Enables weld parameter limit setting.
13. **MODE SELECT PANEL** – The main user interface for weld mode selection, welding parameter adjustment, and multiple levels of user lockouts. Bright 7-segment display and alphanumeric displays enable text messaging for user friendly parameter setup.

POWER-UP SEQUENCE

When power is first applied to the machine, a lamp test is performed. All discrete LED's are turned on, all 7-segment displays will show a pattern of "8." and all alphanumeric displays will show a hatch pattern where every-other pixel is illuminated. The lamp test will last for two seconds, after which all displays are turned back off. The 16-character alphanumeric display will show "Initializing..." while waiting for the Weld Sequencer to configure. The Mode Select Panel alphanumeric displays will then display the name of the weld table loaded in the attached power source while the user interface prepares the machine for operation. After all initialization is complete, the Mode Select Panel will display the weld mode information for the mode number that was selected when the machine was last powered down.

WIRE FEEDER SETUP

Use the INCH UP / INCH DOWN pushbuttons to insert wire into feed mechanism. Prior to inserting the wire, make sure the Touch Sense option is disabled (P.15 in the Setup Menu).

INCH WIRE FEED SPEED SETTING

While pressing either the Inch Up Pushbutton or the Inch Down Pushbutton, the preset wire feed speed will be displayed on the Dual Display panel. This value can be changed while inching wire by turning the WFS Encoder and will be stored into memory.

CHANGING WELD MODES

To select a weld mode, press the left Mode Select Panel pushbutton(7) until the WELD MODE LED(6) is illuminated (it may be illuminated by default at power up). Turn the Mode Select Panel Knob(8) until the desired weld mode number(2) is displayed. As the Mode Select Panel Knob is rotated, only the weld mode number is displayed. After 1 second of knob idle time, the user interface will change to the selected weld mode and the new mode's welding parameters will be displayed.

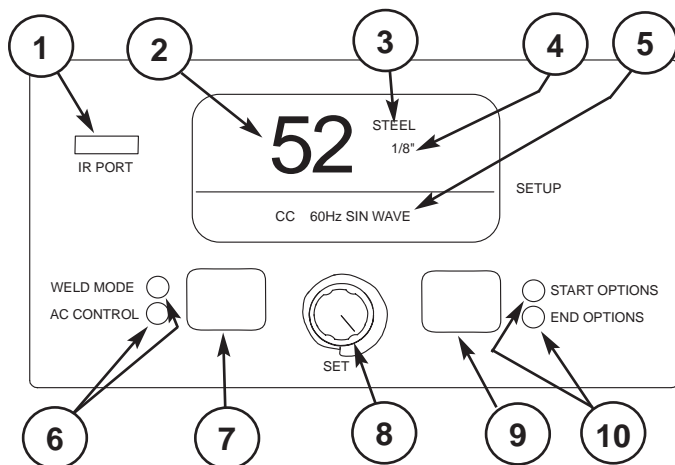

WELD MODE DESCRIPTION

1. Allows wireless machine configuration using a Palm OS based hand-held computer.
2. Consists of easy to read 36 segment alphanumeric LED display.
- 2 Thru 5 Allows for machine set-up/user preferences grouped into secure and non-secure categories.
- 6.- 7. Provides easy access to the multiple weld programs inside the Power Wave power sources. Pushbutton selection for setting AC parameters.
8. Primarily used to change the value of the selected attributes.
- 9.- 10. Provide complete control of the starting and ending sequence. Pushbutton for selecting welding program and parameters.

MODE SELECT PANEL 4 (MSP4)

ITEM	DESCRIPTION
1	IR (Infrared) Port.
2	Weld Mode Number.
3	Weld Wire Type.
4	Wire Size.
5	Weld Mode Description.
6	Weld Mode/AC Control LED's.
7	Selection Pushbutton Weld Mode or AC Control.
8	"Set" (Adjustment) Dial / Knob
9	Selection Pushbutton Start and End Option
10	Start/End Options LED's.

TABLE B.1 *



* This table is located on the inside of front panel door. This Chart will let the operator provide the proper Electrode, Wire size and Weld process for welding.

AC CONTROL

Pressing the Left Mode Select Panel Pushbutton while in WELD MODE will illuminate the AC CONTROL LED (if AC parameters are available). Repeated pressing of the Left Mode Select Panel Pushbutton will scroll through the available parameters. The Mode Select Panel 7-segment display will show the current setting for the parameter and the lower alphanumeric display and will display the name of the parameter. Turning the Mode Select Panel Knob will change the setting. The frequency range will be 10 Hz to 100 Hz. The balance limits will be 25% to 75%. The OFFSET limits will be -50% to +50%. The parameters that can be set by the user in the AC OPTIONS will be as follows:

FREQUENCY (MSP4)
 BALANCE (MSP4)
 OFFSET (MSP4)
 ARC 2 PHASE (MSP4)
 ARC 2 BALANCE (MSP4)
 ARC 3 PHASE (MSP4)
 ARC 3 BALANCE (MSP4)
 ARC 4 PHASE (MSP4)
 ARC 4 BALANCE (MSP4)

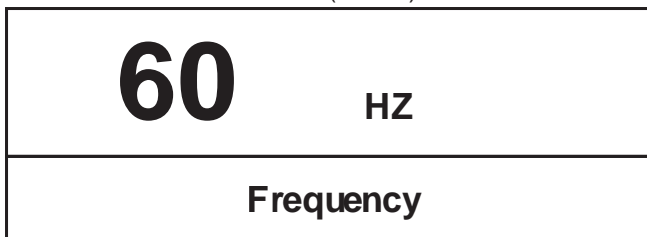

The AC CONTROL parameters can be set to READ ONLY requiring a passcode to be entered in order to change any of the settings. Presently, this can only be done with a Palm or PC application.

START OPTIONS

Pressing the Right Mode Select Panel Pushbutton will illuminate the START OPTIONS LED. Repeated pressing of the Right Mode Select Panel Pushbutton will scroll through the parameters. Turning the Mode Select Panel Knob while on a parameter will change its value. The first settable parameter will be Strike WFS and Volts. The Mode Select Panel upper display will be blank and the lower alphanumeric display will read "Strike" while the Dual Display panel blinks the WFS and Volts LED's prompting the user to enter these parameters. Pressing the Right Mode Select Panel pushbutton again will scroll through the Start parameters. When the Start Time is set to a value other than OFF, the START OPTIONS LED will blink synchronous with the WFS or Amps LED (depending on CC or CV Weld Modes) and with the Volts LED located on the Dual Display Panel prompting the user to enter these parameters. The parameters that can be set by the user in the START OPTIONS will be as follows:

ARC DELAY TIME (MSP4)
 STRIKE WFS (Dual display)
 STRIKE VOLTS (Dual Display)
 START WFS/AMPS (Dual Display)
 START VOLTS (Dual Display)
 START TIME (MSP4)



END OPTIONS

Pressing the Right Mode Select Panel Pushbutton after scrolling through the Start Options will illuminate the END OPTIONS LED. Repeated pressing of the Right Mode Select Panel Pushbutton will toggle through the parameters. Turning the Mode Select Panel Knob while on a parameter will change its value. When the Crater Time is set to a value other than OFF, the END OPTIONS LED will blink synchronous with the WFS or Amps LED (depending on CC or CV Weld Modes) and with the Volts LED located on the Dual Display Panel prompting the user to enter these parameters. The parameters that can be set by the user in the END OPTIONS will be as follows:

CRATER WFS/AMPS (Dual Display)
 CRATER VOLTS (Dual Display)
 CRATER TIME (MSP4)
 BURNBACK TIME (MSP4)

<h1 style="margin: 0;">1.3</h1> <p style="margin: 0;">Seconds</p>
<p style="margin: 0;">Crater Time</p>

SETUP MODE OPTIONS

The Setup Mode can be entered at any time by pressing both Mode Select Panel Pushbuttons simultaneously. The SETUP LED will illuminate. Pressing both Mode Select Panel Pushbuttons simultaneously while the P number is blinking will exit the Setup Mode. The Setup Mode will be exited automatically after 1 minute of inactivity.

There are two different levels of user preferences in the Setup Mode – non-secure and secure. Accessing secured parameters requires initialization using a Palm or PC utility.

Welding parameters that will be factory set to default values or adjusted by a relatively small percentage of users will be made available in the SETUP MODE. These parameters will include the following:

STRIKE FAULT TIME (MSP4-seconds)
 START ARC FORCE (Dual Display-Amps)
 DOWNSLOPE TIME (MSP4-seconds)
 UPSLOPE TIME (MSP4-seconds)
 CRATER ARC FORCE (Dual Display-Amps)
 WELD ARC FORCE (Dual Display-Amps)

<h1 style="margin: 0;">P.11</h1> <p style="margin: 0;">Set Timers</p>	<p style="margin: 0;">SETUP</p>
<p style="margin: 0;">Yes</p>	

RESTRIKE TIME (MSP4-seconds)

Turning the Mode Select Panel Knob will toggle through all user preferences and factory set welding parameters. The lower alphanumeric display will read "Yes" prompting the user to press the right Pushbutton to enter into the chosen parameter set, if available.

Once the parameter set has been selected, turning the Mode Select Panel Knob will toggle through the parameters available in the selected set while showing the current setting for each parameter in the 7-segment display. The parameters will blink in the Mode Select Panel lower alphanumeric display prompting the user to press the right Mode Select Panel Pushbutton to select the parameter. Once the parameter has been selected, the lower Mode Select Panel alphanumeric display will no longer blink the parameter and the current setting of the parameter will blink in the Mode Select Panel 7-segment display prompting the user to change the setting. Pressing the left Mode Select Panel Pushbutton will exit the parameter setting section, returning to the previous section. Continuing to press the left Mode Select Panel Pushbutton will return to the Setup Mode user preferences and welding parameters list.

<h1 style="margin: 0;">0.3</h1> <p style="margin: 0;">Seconds</p>	<p style="margin: 0;">SETUP</p>
<p style="margin: 0;">Downslope Time</p>	

WELD SEQUENCE PARAMETER LIST

PARAMETER	UNITS	RANGE	DEFAULT VALUE	WHERE IS IT SET?
Arc Delay Time	seconds	0-5.0	OFF	MSP4 - START OPTIONS
Strike Fault Time	seconds	0-10.0	OFF	MSP4- SETUP Menu
Strike WFS	IPM	from weld table*	weld mode dependant	Left Dual Display
Strike Volts	volts	from weld table*	weld mode dependant	Right Dual Display
Restrike Time	seconds	0-10.0	OFF	MSP4 - SETUP Menu
Start WFS/Amps	IPM/amperes	from weld table*	weld mode dependant	Left Dual Display
Start Volts	volts	from weld table*	weld mode dependant	Right Dual Display
Start Time	seconds	0-0.5	0.1	MSP4 - START OPTIONS
Start Arc Force	amperes	from weld table*	weld mode dependant	MSP4 - SETUP Menu
Upslope Time	seconds	0-10.0	OFF	MSP4 - SETUP Menu
Weld WFS/Amps	IPM/amperes	from weld table*	weld mode dependant	Left Dual Display
Weld Volts	volts	from weld table*	weld mode dependant	Right Dual Display
Weld Arc Force	amperes	from weld table*	weld mode dependant	MSP4 - SETUP Menu
Frequency (AC)	hertz	10-100	weld mode dependant	AC CONTROL
Balance (AC)	percent	25-75	weld mode dependant	AC CONTROL
Offset (AC)	percent	-50.0 - +50.0	0.0	AC CONTROL
Arc 2 Phase (if applicable)	degrees	0-359	90	AC CONTROL
Arc 2 Balance (if applicable)	percent	25-75	50	AC CONTROL
Arc 3 Phase (if applicable)	degrees	0-359	180	AC CONTROL
Arc 3 Balance (if applicable)	percent	25-75	50	AC CONTROL
Arc 4 Phase (if applicable)	degrees	0-359	270	AC CONTROL
Arc 4 Balance (if applicable)	percent	25-75	50	AC CONTROL
Downslope Time	seconds	0-10.0	OFF	MSP4 - SETUP Menu
Crater WFS/Amps	IPM/amperes	from weld table*	weld mode dependant	Left Dual Display
Crater Volts	volts	from weld table*	weld mode dependant	Right Dual Display
Crater Time	seconds	0-10.0	OFF	END OPTIONS
Crater Arc Force	amperes	from weld table*	weld mode dependant	MSP4 - SETUP Menu
Burnback Time	seconds	0-2.0	0.2	END OPTIONS

* Range depends on the Machine Power Source, Literature and Tables supplied with each unit.

GENERAL SETUP MODE OPTIONS

The Setup Mode can be used to set more general welding configurations such as travel options or display configurations and can be used to access diagnostic tools.

The POWER FEED™ 10A CONTROLLER can be configured to display the wire feed speed in inches per minute or meters per minute, and/or display wire feed speed or Amps in any weld mode. To access the wire feed speed units in the Setup Mode, enter into the Setup Mode by pressing both Mode Select Panel Pushbuttons simultaneously. The SETUP LED will illuminate. Turn the Mode Select Panel Knob until WFS UNITS is listed.

P.1	English
WFS Units	

SETUP

- Press the right Mode Select Button.
- Turn the Knob to toggle between English and Metric.

To set the display to read Wire Feed Speed or Amps, turn the Mode Select Knob until ARC DISPLAY MODE is listed.

P.2	Amps
Arc Display Mode	

SETUP

- Press the right Mode Select Button.
- Turn the Knob to toggle between Amps or WFS.

The POWER FEED™ 10A CONTROLLER can start and stop travel based on the START and STOP Pushbuttons, or based on the arc being established or extinguished. To access the Travel Options in the Setup Mode, enter into the Setup Mode by pressing both Mode Select Panel Pushbuttons simultaneously. The SETUP LED will illuminate. Turn the Mode Select Panel Knob until TRAVEL OPTIONS is listed.

P.12	Travel Options
Yes	

SETUP

Pressing the right Mode Select Panel Pushbutton will enter into the Travel Options. Turning the Mode Select Panel Knob will toggle between TRAVEL STARTS and TRAVEL STOPS. Pressing the right Mode Select Panel Pushbutton, will allow the travel to be set to start on the START BUTTON or on the ARC STRIKE, and to stop on the STOP BUTTON or on the ARC OUT.

P.12	Start Button
Travel Starts	

SETUP

P.12	Arc Out
Travel Ends	

SETUP

This item allows the user to reset the consumable weight to the initial weight set in Production Monitoring. This option only appears in the list when Production Monitoring is installed in the system.

P.14	Reset Wire?
Yes	

- Press the right Mode Select Button to reset, left to cancel.

P.15	Enabled
Touch Sense	

- Press the right Mode Select Button.
- Turn the Knob to toggle between Enabled or Disabled.

This option allows the user to enable or disable touch sense when inching down the wire.

Disabled = Default behavior, touch sense is disabled while inching down.

Enable= Touch sensing is enabled while inching down.

<h1>P.21</h1>	Standard
	Shutdown
Shutdown2 Select	

- Press the right Mode Select Button.
- Turn the Knob to toggle between Standard Shutdown or Output Lockout.

This option allows the user to use the shutdown 2 input on the control box to lock the welding output in the OFF state, but still allow cold feeding of the wire.

Standard Shutdown = Default behavior, normal shutdown mode prevents cold feed of wire.

Output Lockout = Allows cold feed of wire and prevents the activation of welding output.

- Pressing the left Mode Select Panel Pushbutton will exit the parameter setting section, returning to the previous section. Continuing to press the left Mode Select Panel Pushbutton will return to the Setup Mode user preferences and welding parameters list.
- Diagnostic tools SHOW TEST MODES and VIEW DIAGS can be accessed in the Mode Select Panel Setup Mode also, but these tools should only be accessed by properly trained personnel.

INFRARED (IR) CONTROL

The Mode Select Panel interface includes an infrared transceiver. This allows wireless machine configuration using a Palm OS based handheld computer. A proprietary Palm OS application, ALPalm, has been developed for this purpose.

LOCKOUT/SECURITY

The Power Feed 10A can be optionally configured to prevent the operator from changing selected Power Feed 10A panel controls. By default, the welder will be able to change the weld mode, all relevant wave controls and all relevant start and end options.

Here is a list of Lockout levels:

PANEL	LOCKOUT LEVEL
Mode Select	All Mode Select options unlocked (default).
	All Mode Select options locked.
	START OPTIONS and END OPTIONS locked.
	WELD MODE selection locked, only wave controls are unlocked (useful when Memory Panel is used to recall weld modes).
	AC CONTROL locked.
Memory Panel	START OPTIONS, END OPTIONS, and wave options locked.
	START OPTIONS, END OPTIONS, and WELD MODE locked.
	All memories enabled (default).
	All memories disabled.
Encoder Panel	Memories 2-6 disabled.
	Memories 3-6 disabled.
	Memories 4-6 disabled.
	Memories 5-6 disabled.
	Memory 6 disabled.
	Both knobs unlocked (default).
Encoder Panel	Both knobs locked.
	Right knob locked.
	Left knob locked.

Note that when an option is locked, its value can still be monitored. For example, if start and end options are locked, the welder can still press the right Mode Select Panel Pushbutton and see the value set for Start Time. If the welder attempts to change its value, a message will briefly appear on the Mode Select Panel indicating "MSP Option is LOCKED!".

Presently, lockout features are only available through a PC application or the IR Port.

MEMORY PANEL DESCRIPTION



This panel performs these functions: limit setting and memory saving/restoring. There are six user memories.

PROCEDURE MEMORY VS. USER MEMORY

Procedure memory is used while welding. Changes to the Power Feed 10A controls immediately change the contents of the selected procedure's memory, such as Wire Feed Speed or Volts. Procedure memory saving is done automatically. When the Power Feed 10A is powered up, the previous settings at power down will be restored.

Memory Panel user memories are used as storage and are not directly used while welding. When a user memory is recalled, the contents of the user memory are copied into the selected procedure where it can be used for welding. The user must explicitly save user memories on the Memory Panel.

MEMORY RECALLING

To recall a user memory, press and release the desired memory button. The memory is recalled when the button is released. When recalling a memory, do not hold the memory button in for more than two seconds. A memory cannot be recalled while the output is enabled. The selected memory location (1-6) will illuminate the corresponding LED indicating that this memory location has been recalled. The LED will stay illuminated as long as no parameters are changed. Once any parameter is changed, the corresponding memory LED will turn off indicating that the stored values are no longer identical to the displayed values. However, this does not affect the stored values in this particular memory location.

MEMORY SAVING

The Memory Panel enables the saving of all weld parameters and all user settable parameters, such as timers, Start Options, End Options, AC Controls, etc. To save a memory, press and hold the desired memory button for two seconds. When the memory button is initially pressed, its indicator LED will illuminate.

After holding the memory button in for two seconds the LED will turn off, indicating that the memory will be saved when the button is released. When saving a memory, do not hold the memory button in for more than five seconds.

Memory saving can be optionally disabled using Lockout Levels. If the user attempts to save a memory when memory saving is locked, the Mode Select Panel will briefly display "Memory Save is DISABLED!". Presently, Memory Panel Lockout Levels can only be accessed through a PC application or the IR Port.

MULTI PROCEDURE WELDING

The POWER FEED™ 10A CONTROLLER can do "On-The-Fly" welding with multiple weld procedures by using the Memory Panel. While welding, any Memory location can be accessed, and the parameters stored in that memory location will be switched to while actively welding. **NOTE - This can only be done with Memory locations that have the same Weld Mode!** While welding, any Memory location trying to be accessed with a different Weld Mode than the one currently being used will be ignored and an error message will be displayed. Up to six different weld procedures can be used while actively welding by using all six memory locations, as long as each location utilizes the same Weld Modes.

LIMIT SETTING

Each user memory can be optionally configured to limit the user's range of control over some user interface settings. By default, user limits are not enabled. To set limits for a selected memory, first select a weld mode and perform a memory save. Next, press and hold the memory button for five seconds. Release the memory button when the memory LED begins to blink rapidly and the Mode Select Panel displays indicate "Set Limits".

If the passcode has been set to a value other than zero, the user will be prompted to enter it. If the passcode is zero, the Mode Select Panel will immediately display the Limit Setup menu and the SETUP LED will illuminate:

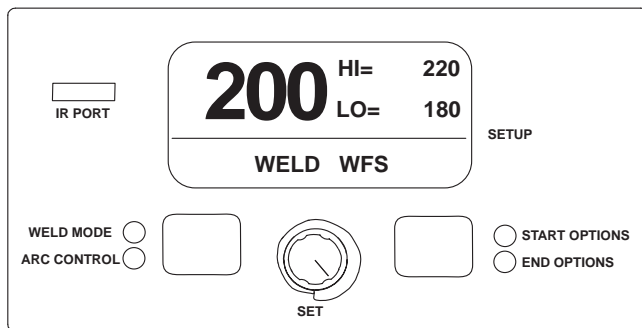

The above example shows a wire mode, constant current weld modes would show "Weld Amps" rather than "Weld WFS".

There are four items displayed on each Limit Setup screen. The long alphanumeric display shows the selected attribute (e.g. Weld WFS,Volts, etc.). The short alphanumeric displays show the selected attribute's high and low user limits. The 7-segment displays show the value that is copied to procedure memory when a memory recall is performed.

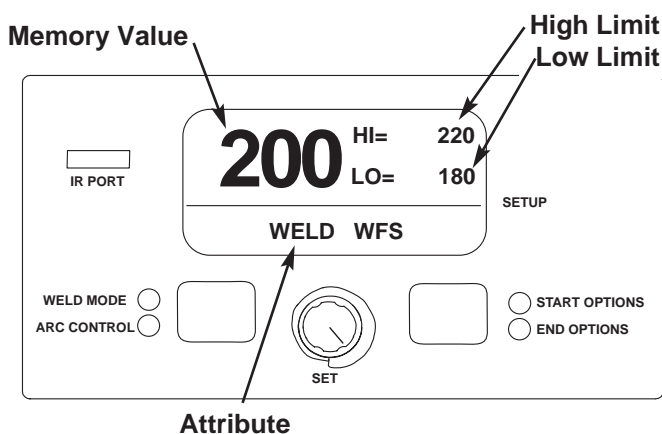

One of these four items will blink to indicate which item will change when the Mode Select Panel Knob is rotated. Initially, the selected item will be the attribute. To select the high limit, press either Mode Select Panel button and the high limit value will begin to blink. Pressing either Mode Select Panel button again will cause the memory value to blink, pressing a third time will cause the low limit to blink.

Weld modes cannot be selected from the Limits Setup menu; the mode must be selected and saved to memory prior to entering the Limits Setup menu.

The memory value, high and low limit values are bound by the limits of the machine. For example, weld mode 49 may allow the wire feed speed to be adjusted between 10 and 200 in/min. These are referred to as "machine limits". Machine limits can vary between power sources and are also weld mode dependent.

The memory value must always be less than or equal to the high limit and greater than or equal to the low limit. The high limit must always be greater than or equal to the low limit and the low limit must always be less than or equal to the high limit. The rules are enforced automatically. If the low limit is increased above the memory value, the memory value will automatically increase.

To lock an attribute to a specific value, set the high and low limits to the desired value. The user will not be able to change it.

After setting limits, press the memory button that is flashing. The Mode Select Panel displays will prompt the user to save or discard the limit changes just made.

By pressing the Mode Select Panel button labeled YES, changes to limits are saved and user limits are automatically enabled. By pressing NO, any changes made to limits are discarded and the limit enable/disable state is not changed.

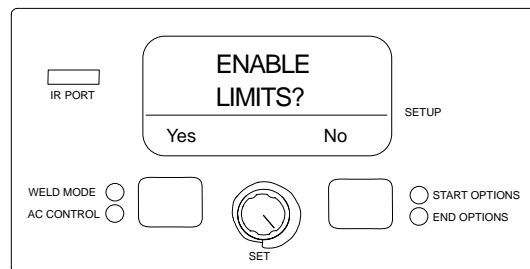

To enable or disable limits that have been established for any memory, press and hold the respective memory button in for more than 10 seconds until the Mode Select Panel displays "Enable Limits?" Pressing "Yes" will use the established limits, while pressing "No" will ignore the established limits. The limits that have been set for any memory location will not be erased if they are disabled.

GENERAL OPTIONS / ACCESSORIES

K2311-1 Power Feed 10SM -Converts NA style wire drives into Power Feed-10S Wire Drives	K325 TC-3 Travel Carriage
K2370-1 Power Feed 10S Wire Drive -Power Feed-10S with hardware to connect to a TC-3 Travel Carriage.	K299 Wire Reel Assembly for 50-60lbs Coils
K2282-1 System Interface -Includes phase generator for multiple arcs.	K162-1 Spindle Kit – 2in. hub
K1543-xx ArcLink Cables -ArcLink cable of length "xx".	K29 Vertical Lift Adjuster
K1842-110 Weld Power Cable -Lug to Lug, 4/0 Cable of length 110ft.	K96 Horizontal Adjuster
K2163-xx Weld Power Cable -Lug to Lug, 4/0 Cable of length "xx"	K278 SpreadArc Oscillator
K1795-xx Power Wave to System Interface Cable	K310 Flux Screen – Air Driven Vibrator
K1785-xx Wire Drive Cable	K58 Magnetic Separator
K231-x Contact Nozzle Assembly	
K226R Contact Jaw Assembly	
K148 Positive Contact Assembly	
K149 Linc-Fill Attachments	
K386 Narrow Gap Deep Groove Nozzle	
K285 Concentric Flux Cone Assembly	
K225 Twinarc Contact Assemblies	
K129 Tiny Twinarc Assemblies	
K281 Tiny Twinarc Solid Wire Straightener	

SAFETY PRECAUTIONS

WARNING

ELECTRIC SHOCK can kill.



- Do not touch electrically live parts such as output terminals or internal wiring.
- When inching, electrode and drive mechanism are “hot” to work and ground and could remain energized several seconds after the inch button is released.

- Turn OFF input power at welding power source before installation or changing drive roll and/or guide tubes.
- Welding power source must be connected to system ground per the National Electrical Code or any applicable local codes.
- Only qualified personnel should perform maintenance work.

See additional warning information throughout this operator’s manual and the Engine manual as well.

ROUTINE MAINTENANCE

- Check weld cables, control cables and gas hoses for cuts.
- Clean and tighten all weld terminals.
- Inspect and clean drive rolls and inner wire guide and replace if worn.

PERIODIC MAINTENANCE

- Blow out or vacuum the inside of the feeder.
- Every six months check the motor brushes. Replace them if they are less than 1/4”(6.4mm) long.
- Every year inspect the gearbox and coat the gear teeth with a moly-disulfide filled grease. DO NOT use graphite grease.

CALIBRATION SPECIFICATION

All calibration is factory set on the POWER FEED™ 10A CONTROLLER.

To verify the wire feed speed:

- Press the INCH DOWN switch and adjust the wire feed speed to 100 in/min (2.54m/min).
- Measure the actual wire feed speed with a calibrated wire feed speed tachometer.

The measured wire feed speed should be within $\pm 2\%$ of the set value.

HOW TO USE TROUBLESHOOTING GUIDE

WARNING

Service and Repair should only be performed by Lincoln Electric Factory Trained Personnel. Unauthorized repairs performed on this equipment may result in danger to the technician and machine operator and will invalidate your factory warranty. For your safety and to avoid Electrical Shock, please observe all safety notes and precautions detailed throughout this manual.

This Troubleshooting Guide is provided to help you locate and repair possible machine malfunctions. Simply follow the three-step procedure listed below.

Step 1. LOCATE PROBLEM (SYMPTOM).

Look under the column labeled “PROBLEM (SYMPTOMS)”. This column describes possible symptoms that the machine may exhibit. Find the listing that best describes the symptom that the machine is exhibiting.

Step 2. POSSIBLE CAUSE.

The second column labeled “POSSIBLE CAUSE” lists the obvious external possibilities that may contribute to the machine symptom.

Step 3. RECOMMENDED COURSE OF ACTION

This column provides a course of action for the Possible Cause, generally it states to contact your local Lincoln Authorized Field Service Facility.

If you do not understand or are unable to perform the Recommended Course of Action safely, contact your local Lincoln Authorized Field Service Facility.

CAUTION

If for any reason you do not understand the test procedures or are unable to perform the tests/repairs safely, contact your **Local Lincoln Authorized Field Service Facility** for technical troubleshooting assistance before you proceed.

Observe all Safety Guidelines detailed throughout this manual

PROBLEMS (SYMPTOMS)		POSSIBLE CAUSE	RECOMMENDED COURSE OF ACTION
LINC-NET SYSTEM ERROR CODES			
Err 006		<ol style="list-style-type: none"> 1. The wire feeder has not received a recognition command from the power source. Verify the power source is operating properly (Status light steady green.) 2. Check control cable for loose or broken leads. 3. See power source Instruction Manual. 	<p>If all recommended possible areas of misadjustment have been checked and the problem persists, Contact your local Lincoln Authorized Field Service Facility.</p>
Err 100		<ol style="list-style-type: none"> 1. The power source has issued a shutdown command. Verify the power source is operating properly. (Status light steady green.) 2. Check control cable for loose or broken leads. 3. See power source instruction Manual. 	
ARCLINK SYSTEM ERROR CODES			
Err 31	Primary overcurrent	<ol style="list-style-type: none"> 1. The power source has exceeded input current limits. Adjust the welding procedure to reduce the current draw. The welding procedure may exceed the capacity of the power source. 2. See the power source Instruction Manual. 	
Err 32	Capacitor bank "A" under voltage.	<ol style="list-style-type: none"> 1. The power source input power may be wired incorrectly. Verify the power source reconnect panel wiring matches the input power. 2. See the power source Instruction Manual. 	

⚠ CAUTION

If for any reason you do not understand the test procedures or are unable to perform the tests/repairs safely, contact your **Local Lincoln Authorized Field Service Facility** for technical troubleshooting assistance before you proceed.

POWER FEED™ 10A CONTROLLER



Observe all Safety Guidelines detailed throughout this manual

PROBLEMS (SYMPTOMS)		POSSIBLE CAUSE	RECOMMENDED COURSE OF ACTION
ARCLINK SYSTEM ERROR CODES			
Err 33	Capacitor bank "B" under voltage.	<ol style="list-style-type: none"> 1. The power source input power may be wired incorrectly. Verify the power source reconnect panel wiring matches the input power. 2. See the power source Instruction Manual. 	<p>If all recommended possible areas of misadjustment have been checked and the problem persists, Contact your local Lincoln Authorized Field Service Facility.</p>
Err 34	Capacitor bank "A" overvoltage.	<ol style="list-style-type: none"> 1. The power source input power may be wired incorrectly. Verify the power source reconnect panel wiring matches the input power. 2. See the power source Instruction Manual. 	
Err 35	Capacitor bank "B" overvoltage.	<ol style="list-style-type: none"> 1. The power source input power may be wired incorrectly. Verify the power source reconnect panel wiring matches the input power. 2. See the power source Instruction Manual. 	
Err 36	Thermal	<ol style="list-style-type: none"> 1. Power source overheating. Verify duty cycle is correct. Ensure adequate airflow around power source. 	
Err 41	Long term secondary overcurrent.	<ol style="list-style-type: none"> 1. The power source has exceeded the output current limits. Adjust the welding procedure to reduce the current draw. The welding procedure may exceed the capacity of the power source. 2. See the power source Instruction Manual. 	
Err 43	Capacitors are out of balance	<ol style="list-style-type: none"> 1. Verify the power source reconnect panel wiring matches the input power. 2. See the power source Instruction Manual. 	

⚠ CAUTION

If for any reason you do not understand the test procedures or are unable to perform the tests/repairs safely, contact your **Local Lincoln Authorized Field Service Facility** for technical troubleshooting assistance before you proceed.

Observe all Safety Guidelines detailed throughout this manual

PROBLEMS (SYMPTOMS)	POSSIBLE CAUSE	RECOMMENDED COURSE OF ACTION
ARCLINK SYSTEM ERROR CODES		
Err 44 Main CPU problem.	<ol style="list-style-type: none"> 1. Verify the earth ground connection to the power source is wired correctly. 2. See the power source Instruction Manual. 	<p>If all recommended possible areas of misadjustment have been checked and the problem persists, Contact your local Lincoln Authorized Field Service Facility.</p>
Err 53 Voltage sense loss.	<ol style="list-style-type: none"> 1. Verify correct sense lead connection. 	
Err 54 Short term secondary over-current.		
Err 81 Motor overload, long term.	<ol style="list-style-type: none"> 1. The wire drive motor has overheated. Check that the electrode slides easily through the gun and cable. 2. Remove tight bends from the gun and cable. 3. Check that the spindle brake is not too tight. 4. Verify a high quality electrode is being used. 5. Wait for the error to reset and the motor to cool (approximately 1 minute). 	
Err 82 Motor overload, short term.	<ol style="list-style-type: none"> 1. The wire drive motor current draw has exceeded limits, usually because the motor is in a locked rotor state. Check that motor can turn freely when idle arm is open. 2. Verify that the gears are free of debris and dirt. 	
Err 263 No usable weld modes.	<ol style="list-style-type: none"> 1. The power source does not have any welding programs loaded. 2. See the power source Instruction Manual for load welding programs. 	

⚠ CAUTION

If for any reason you do not understand the test procedures or are unable to perform the tests/repairs safely, contact your **Local Lincoln Authorized Field Service Facility** for technical troubleshooting assistance before you proceed.

POWER FEED™ 10A CONTROLLER



Observe all Safety Guidelines detailed throughout this manual

PROBLEMS (SYMPTOMS)	POSSIBLE CAUSE	RECOMMENDED COURSE OF ACTION
OUTPUT PROBLEMS		
The feeder does power up - no display, no feed.	<ol style="list-style-type: none"> 1. The Power Wave power source is OFF. Turn ON the Power Wave source. 2. The circuit breaker for the wire feeder on power source has tripped. Reset the circuit breakers. 3. The control cable may be loose or damaged. Tighten, repair or replace the control cable. 4. The power switch is damaged. Replace the power switch. 	<p>If all recommended possible areas of misadjustment have been checked and the problem persists, Contact your local Lincoln Authorized Field Service Facility.</p>
Inconsistent wire feeding or wire not feeding but drive rolls turning.	<ol style="list-style-type: none"> 1. The electrode is rusty or dirty. Use only clean electrode. Use quality electrode, like L-50 or L-56 from Lincoln Electric. 2. The contact tip is partially melted or has spatter. Replace the contact tip. 3. Improper tip, drive rolls and/or inner wire guide. Verify the proper parts are installed. 4. Incorrect tension arm pressure on the drive rolls. Adjust the tension arm per the Instruction Manual. Most electrodes feed well at a tension arm setting of "3". 5. Worn drive roll. Replace the drive rolls if worn or filled with dirt. 	

⚠ CAUTION

If for any reason you do not understand the test procedures or are unable to perform the tests/repairs safely, contact your **Local Lincoln Authorized Field Service Facility** for technical troubleshooting assistance before you proceed.

POWER FEED™ 10A CONTROLLER



Observe all Safety Guidelines detailed throughout this manual

PROBLEMS (SYMPTOMS)	POSSIBLE CAUSE	RECOMMENDED COURSE OF ACTION
OUTPUT PROBLEMS		
Wire feed speed consistently operates at the wrong value.	1. The wire feeder gear setting is not properly set. Verify the software setting matches the gear mounted. See the Instruction Manual for setting the gear speed.	If all recommended possible areas of misadjustment have been checked and the problem persists, Contact your local Lincoln Authorized Field Service Facility.
Variable or "hunting" arc.	1. Wrong size, worn and/or melted contact tip. Replace the contact tip. 2. Worn work cable or poor work connection. Verify all work and electrode connections are tight and that the cables are in good condition. Clean/replace as necessary. 3. Wrong polarity. Adjust polarity to the recommended procedure. Verify DIP switch #7 setting matches the electrode polarity.	

 **CAUTION**

If for any reason you do not understand the test procedures or are unable to perform the tests/repairs safely, contact your **Local Lincoln Authorized Field Service Facility** for technical troubleshooting assistance before you proceed.

POWER FEED™ 10A CONTROLLER



POWER FEED 10A CONTROLLER

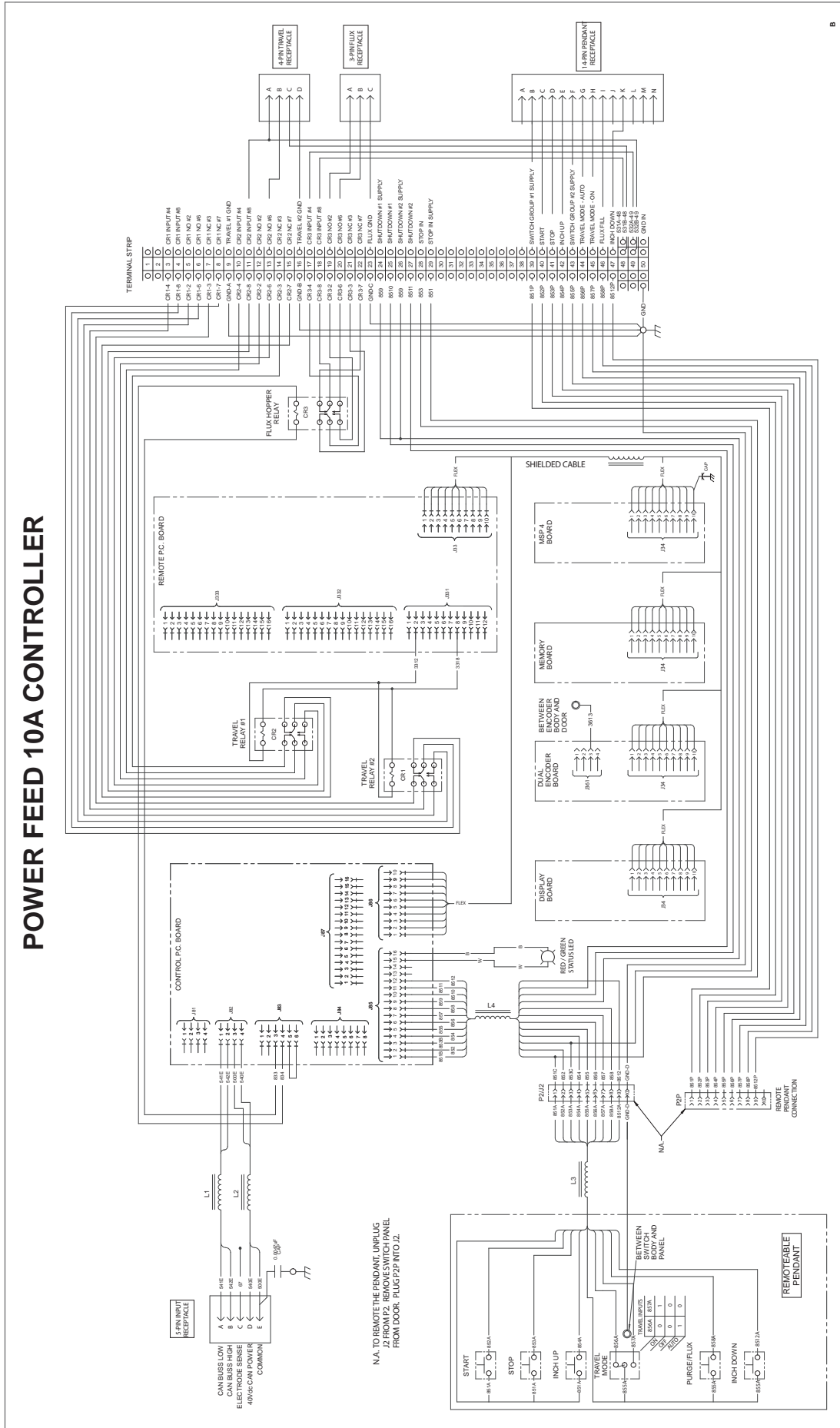

G4610

NOTE: This diagram is for reference only. It may not be accurate for all machines covered by this manual. The specific diagram for a particular code is pasted inside the machine on one of the enclosure panels. If the diagram is illegible, write to the Service Department for a replacement. Give the equipment code number.

POWER FEED™ 10A CONTROLLER



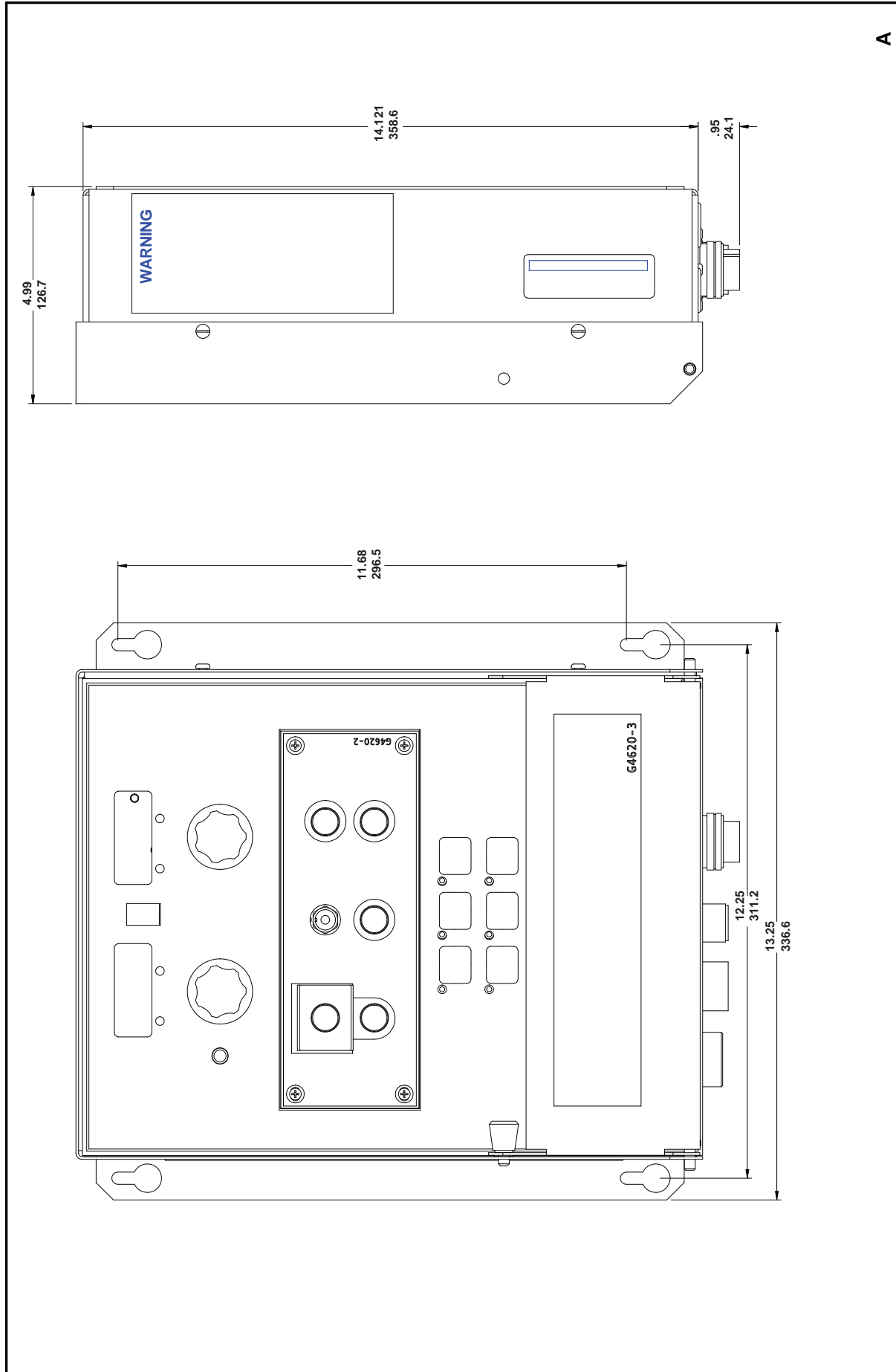

A
M20414

POWER FEED™ 10A CONTROLLER



			
WARNING	<ul style="list-style-type: none"> Do not touch electrically live parts or electrode with skin or wet clothing. Insulate yourself from work and ground. 	<ul style="list-style-type: none"> Keep flammable materials away. 	<ul style="list-style-type: none"> Wear eye, ear and body protection.
Spanish AVISO DE PRECAUCION	<ul style="list-style-type: none"> No toque las partes o los electrodos bajo carga con la piel o ropa mojada. Aíslese del trabajo y de la tierra. 	<ul style="list-style-type: none"> Mantenga el material combustible fuera del área de trabajo. 	<ul style="list-style-type: none"> Protéjase los ojos, los oídos y el cuerpo.
French ATTENTION	<ul style="list-style-type: none"> Ne laissez ni la peau ni des vêtements mouillés entrer en contact avec des pièces sous tension. Isolez-vous du travail et de la terre. 	<ul style="list-style-type: none"> Gardez à l'écart de tout matériel inflammable. 	<ul style="list-style-type: none"> Protégez vos yeux, vos oreilles et votre corps.
German WARNUNG	<ul style="list-style-type: none"> Berühren Sie keine stromführenden Teile oder Elektroden mit Ihrem Körper oder feuchter Kleidung! Isolieren Sie sich von den Elektroden und dem Erdboden! 	<ul style="list-style-type: none"> Entfernen Sie brennbares Material! 	<ul style="list-style-type: none"> Tragen Sie Augen-, Ohren- und Körperschutz!
Portuguese ATENÇÃO	<ul style="list-style-type: none"> Não toque partes elétricas e electrodos com a pele ou roupa molhada. Isole-se da peça e terra. 	<ul style="list-style-type: none"> Mantenha inflamáveis bem guardados. 	<ul style="list-style-type: none"> Use proteção para a vista, ouvido e corpo.
Japanese 注意事項	<ul style="list-style-type: none"> 通電中の電気部品、又は溶材にヒブやぬれた布で触れないこと。 施工物やアースから身体が絶縁されている様にして下さい。 	<ul style="list-style-type: none"> 燃えやすいものの側での溶接作業は絶対にしてはなりません。 	<ul style="list-style-type: none"> 目、耳及び身体に保護具をして下さい。
Chinese 警告	<ul style="list-style-type: none"> 皮肤或湿衣物切勿接触带电部件及焊条。 使你自己与地面和工件绝缘。 	<ul style="list-style-type: none"> 把一切易燃物品移离工作场所。 	<ul style="list-style-type: none"> 佩戴眼、耳及身体劳动保护用具。
Korean 위험	<ul style="list-style-type: none"> 전도체나 용접봉을 젖은 헝겍 또는 피부로 절대 접촉치 마십시오. 모재와 접지를 접촉치 마십시오. 	<ul style="list-style-type: none"> 인화성 물질을 접근시키지 마십시오. 	<ul style="list-style-type: none"> 눈, 귀와 몸에 보호장구를 착용하십시오.
Arabic تحذير	<ul style="list-style-type: none"> لا تلمس الاجزاء التي يسري فيها التيار الكهربائي أو الألكترود بجك الجسم أو بالملابس المبللة بالماء. ضع عازل على جسمك خلال العمل. 	<ul style="list-style-type: none"> ضع المواد القابلة للاشتعال في مكان بعيد. 	<ul style="list-style-type: none"> ضع أدوات وملابس واقية على عينيك وأذنيك وجسمك.

READ AND UNDERSTAND THE MANUFACTURER'S INSTRUCTION FOR THIS EQUIPMENT AND THE CONSUMABLES TO BE USED AND FOLLOW YOUR EMPLOYER'S SAFETY PRACTICES.

SE RECOMIENDA LEER Y ENTENDER LAS INSTRUCCIONES DEL FABRICANTE PARA EL USO DE ESTE EQUIPO Y LOS CONSUMIBLES QUE VA A UTILIZAR, SIGA LAS MEDIDAS DE SEGURIDAD DE SU SUPERVISOR.

LISEZ ET COMPRENEZ LES INSTRUCTIONS DU FABRICANT EN CE QUI REGARDE CET EQUIPMENT ET LES PRODUITS A ETRE EMPLOYES ET SUIVEZ LES PROCEDURES DE SECURITE DE VOTRE EMPLOYEUR.

LESEN SIE UND BEFOLGEN SIE DIE BETRIEBSANLEITUNG DER ANLAGE UND DEN ELEKTRODENEINSATZ DES HERSTELLERS. DIE UNFALLVERHÜTUNGSVORSCHRIFTEN DES ARBEITGEBERS SIND EBENFALLS ZU BEACHTEN.

			
<ul style="list-style-type: none"> ● Keep your head out of fumes. ● Use ventilation or exhaust to remove fumes from breathing zone. 	<ul style="list-style-type: none"> ● Turn power off before servicing. 	<ul style="list-style-type: none"> ● Do not operate with panel open or guards off. 	WARNING
<ul style="list-style-type: none"> ● Los humos fuera de la zona de respiración. ● Mantenga la cabeza fuera de los humos. Utilice ventilación o aspiración para gases. 	<ul style="list-style-type: none"> ● Desconectar el cable de alimentación de poder de la máquina antes de iniciar cualquier servicio. 	<ul style="list-style-type: none"> ● No operar con panel abierto o guardas quitadas. 	Spanish AVISO DE PRECAUCION
<ul style="list-style-type: none"> ● Gardez la tête à l'écart des fumées. ● Utilisez un ventilateur ou un aspirateur pour ôter les fumées des zones de travail. 	<ul style="list-style-type: none"> ● Débranchez le courant avant l'entretien. 	<ul style="list-style-type: none"> ● N'opérez pas avec les panneaux ouverts ou avec les dispositifs de protection enlevés. 	French ATTENTION
<ul style="list-style-type: none"> ● Vermeiden Sie das Einatmen von Schweißrauch! ● Sorgen Sie für gute Be- und Entlüftung des Arbeitsplatzes! 	<ul style="list-style-type: none"> ● Strom vor Wartungsarbeiten abschalten! (Netzstrom völlig öffnen; Maschine anhalten!) 	<ul style="list-style-type: none"> ● Anlage nie ohne Schutzgehäuse oder Innenschutzverkleidung in Betrieb setzen! 	German WARNUNG
<ul style="list-style-type: none"> ● Mantenha seu rosto da fumaça. ● Use ventilação e exaustão para remover fumo da zona respiratória. 	<ul style="list-style-type: none"> ● Não opere com as tampas removidas. ● Desligue a corrente antes de fazer serviço. ● Não toque as partes elétricas nuas. 	<ul style="list-style-type: none"> ● Mantenha-se afastado das partes moventes. ● Não opere com os painéis abertos ou guardas removidas. 	Portuguese ATENÇÃO
<ul style="list-style-type: none"> ● ヒュームから頭を離すようにして下さい。 ● 換気や排煙に十分留意して下さい。 	<ul style="list-style-type: none"> ● メンテナンス・サービスに取りかかる際には、まず電源スイッチを必ず切って下さい。 	<ul style="list-style-type: none"> ● パネルやカバーを取り外したまま機械操作をしないで下さい。 	Japanese 注意事項
<ul style="list-style-type: none"> ● 頭部遠離煙霧。 ● 在呼吸區使用通風或排風器除煙。 	<ul style="list-style-type: none"> ● 維修前切斷電源。 	<ul style="list-style-type: none"> ● 儀表板打開或沒有安全罩時不準作業。 	Chinese 警告
<ul style="list-style-type: none"> ● 얼굴로부터 용접가스를 멀리하십시오. ● 호흡지역으로부터 용접가스를 제거하기 위해 가스제거기나 통풍기를 사용하십시오. 	<ul style="list-style-type: none"> ● 보수전에 전원을 차단하십시오. 	<ul style="list-style-type: none"> ● 관널이 열린 상태로 작동치 마십시오. 	Korean 위험
<ul style="list-style-type: none"> ● ابعء رأسك بعيداً عن الدخان. ● استعمل التهوية أو جهاز ضغط الدخان للخارج لكي تبعد الدخان عن المنطقة التي تتنفس فيها. 	<ul style="list-style-type: none"> ● اقطع التيار الكهربائي قبل القيام بأية صيانة. 	<ul style="list-style-type: none"> ● لا تشغيل هذا الجهاز اذا كانت الاغطية الحديدية الواقية ليست عليه. 	Arabic تحذير

LEIA E COMPREENDA AS INSTRUÇÕES DO FABRICANTE PARA ESTE EQUIPAMENTO E AS PARTES DE USO, E SIGA AS PRÁTICAS DE SEGURANÇA DO EMPREGADOR.

使う機械や溶材のメーカーの指示書をよく読み、まず理解して下さい。そして貴社の安全規定に従って下さい。

請詳細閱讀並理解製造廠提供的說明以及應該使用的銀焊材料，並請遵守貴方的有關勞動保護規定。

이 제품에 동봉된 작업지침서를 숙지하시고 귀사의 작업자 안전수칙을 준수하시기 바랍니다.

اقرأ بتعمن وأفهم تعليمات المصنع المنتج لهذه المعدات والمواد قبل استعمالها واتبع تعليمات الوقاية لصاحب العمل.



• World's Leader in Welding and Cutting Products •

• Sales and Service through Subsidiaries and Distributors Worldwide •

Cleveland, Ohio 44117-1199 U.S.A. TEL: 216.481.8100 FAX: 216.486.1751 WEB SITE: www.lincolnelectric.com