

Power Feed 10 Robotic K1780-1

IM689-A

May, 2007

For use with machines having code numbers: 10729,10801

Safety Depends on You

Lincoln arc welding and cutting equipment is designed and built with safety in mind. However, your overall safety can be increased by proper installation ... and thoughtful operation on your part. **DO NOT INSTALL, OPERATE OR REPAIR THIS EQUIPMENT WITHOUT READING THIS MANUAL AND THE SAFETY PRECAUTIONS CONTAINED THROUGHOUT.** And, most importantly, think before you act and be careful.

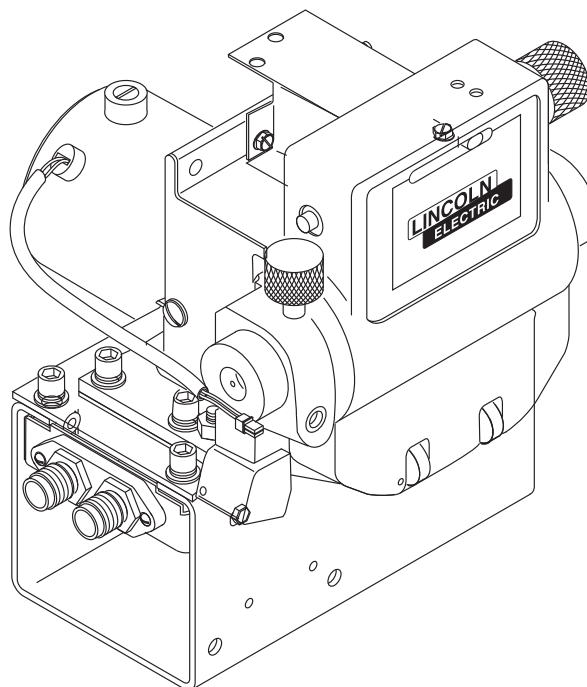

OPERATOR'S MANUAL

LINCOLN[®]
ELECTRIC

Copyright © 2007 Lincoln Global Inc.

• World's Leader in Welding and Cutting Products •

• Sales and Service through Subsidiaries and Distributors Worldwide •

Cleveland, Ohio 44117-1199 U.S.A. TEL: 216.481.8100 FAX: 216.486.1751 WEB SITE: www.lincolnelectric.com

⚠ WARNING

⚠ CALIFORNIA PROPOSITION 65 WARNINGS ⚠

Diesel engine exhaust and some of its constituents are known to the State of California to cause cancer, birth defects, and other reproductive harm.

The Above For Diesel Engines

The engine exhaust from this product contains chemicals known to the State of California to cause cancer, birth defects, or other reproductive harm.

The Above For Gasoline Engines

ARC WELDING CAN BE HAZARDOUS. PROTECT YOURSELF AND OTHERS FROM POSSIBLE SERIOUS INJURY OR DEATH. KEEP CHILDREN AWAY. PACEMAKER WEARERS SHOULD CONSULT WITH THEIR DOCTOR BEFORE OPERATING.

Read and understand the following safety highlights. For additional safety information, it is strongly recommended that you purchase a copy of "Safety in Welding & Cutting - ANSI Standard Z49.1" from the American Welding Society, P.O. Box 351040, Miami, Florida 33135 or CSA Standard W117.2-1974. A Free copy of "Arc Welding Safety" booklet E205 is available from the Lincoln Electric Company, 22801 St. Clair Avenue, Cleveland, Ohio 44117-1199.

BE SURE THAT ALL INSTALLATION, OPERATION, MAINTENANCE AND REPAIR PROCEDURES ARE PERFORMED ONLY BY QUALIFIED INDIVIDUALS.



FOR ENGINE powered equipment.

1.a. Turn the engine off before troubleshooting and maintenance work unless the maintenance work requires it to be running.



1.b. Operate engines in open, well-ventilated areas or vent the engine exhaust fumes outdoors.



1.c. Do not add the fuel near an open flame welding arc or when the engine is running. Stop the engine and allow it to cool before refueling to prevent spilled fuel from vaporizing on contact with hot engine parts and igniting. Do not spill fuel when filling tank. If fuel is spilled, wipe it up and do not start engine until fumes have been eliminated.

1.d. Keep all equipment safety guards, covers and devices in position and in good repair. Keep hands, hair, clothing and tools away from V-belts, gears, fans and all other moving parts when starting, operating or repairing equipment.

1.e. In some cases it may be necessary to remove safety guards to perform required maintenance. Remove guards only when necessary and replace them when the maintenance requiring their removal is complete. Always use the greatest care when working near moving parts.



1.f. Do not put your hands near the engine fan. Do not attempt to override the governor or idler by pushing on the throttle control rods while the engine is running.

1.g. To prevent accidentally starting gasoline engines while turning the engine or welding generator during maintenance work, disconnect the spark plug wires, distributor cap or magneto wire as appropriate.



1.h. To avoid scalding, do not remove the radiator pressure cap when the engine is hot.

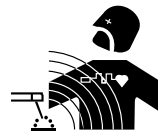

ELECTRIC AND MAGNETIC FIELDS may be dangerous

2.a. Electric current flowing through any conductor causes localized Electric and Magnetic Fields (EMF). Welding current creates EMF fields around welding cables and welding machines

2.b. EMF fields may interfere with some pacemakers, and welders having a pacemaker should consult their physician before welding.

2.c. Exposure to EMF fields in welding may have other health effects which are now not known.

2.d. All welders should use the following procedures in order to minimize exposure to EMF fields from the welding circuit:

2.d.1. Route the electrode and work cables together - Secure them with tape when possible.

2.d.2. Never coil the electrode lead around your body.

2.d.3. Do not place your body between the electrode and work cables. If the electrode cable is on your right side, the work cable should also be on your right side.

2.d.4. Connect the work cable to the workpiece as close as possible to the area being welded.

2.d.5. Do not work next to welding power source.

Mar '95

POWER FEED 10 / R

LINCOLN
ELECTRIC



ELECTRIC SHOCK can kill.

- 3.a. The electrode and work (or ground) circuits are electrically “hot” when the welder is on. Do not touch these “hot” parts with your bare skin or wet clothing. Wear dry, hole-free gloves to insulate hands.
- 3.b. Insulate yourself from work and ground using dry insulation. Make certain the insulation is large enough to cover your full area of physical contact with work and ground.

In addition to the normal safety precautions, if welding must be performed under electrically hazardous conditions (in damp locations or while wearing wet clothing; on metal structures such as floors, gratings or scaffolds; when in cramped positions such as sitting, kneeling or lying, if there is a high risk of unavoidable or accidental contact with the workpiece or ground) use the following equipment:

- Semiautomatic DC Constant Voltage (Wire) Welder.
 - DC Manual (Stick) Welder.
 - AC Welder with Reduced Voltage Control.
- 3.c. In semiautomatic or automatic wire welding, the electrode, electrode reel, welding head, nozzle or semiautomatic welding gun are also electrically “hot”.
- 3.d. Always be sure the work cable makes a good electrical connection with the metal being welded. The connection should be as close as possible to the area being welded.
- 3.e. Ground the work or metal to be welded to a good electrical (earth) ground.
- 3.f. Maintain the electrode holder, work clamp, welding cable and welding machine in good, safe operating condition. Replace damaged insulation.
- 3.g. Never dip the electrode in water for cooling.
- 3.h. Never simultaneously touch electrically “hot” parts of electrode holders connected to two welders because voltage between the two can be the total of the open circuit voltage of both welders.
- 3.i. When working above floor level, use a safety belt to protect yourself from a fall should you get a shock.
- 3.j. Also see Items 6.c. and 8.



ARC RAYS can burn.

- 4.a. Use a shield with the proper filter and cover plates to protect your eyes from sparks and the rays of the arc when welding or observing open arc welding. Headshield and filter lens should conform to ANSI Z87.1 standards.
- 4.b. Use suitable clothing made from durable flame-resistant material to protect your skin and that of your helpers from the arc rays.
- 4.c. Protect other nearby personnel with suitable, non-flammable screening and/or warn them not to watch the arc nor expose themselves to the arc rays or to hot spatter or metal.



FUMES AND GASES can be dangerous.

- 5.a. Welding may produce fumes and gases hazardous to health. Avoid breathing these fumes and gases. When welding, keep your head out of the fume. Use enough ventilation and/or exhaust at the arc to keep fumes and gases away from the breathing zone. **When welding with electrodes which require special ventilation such as stainless or hard facing (see instructions on container or MSDS) or on lead or cadmium plated steel and other metals or coatings which produce highly toxic fumes, keep exposure as low as possible and below Threshold Limit Values (TLV) using local exhaust or mechanical ventilation. In confined spaces or in some circumstances, outdoors, a respirator may be required. Additional precautions are also required when welding on galvanized steel.**
5. b. The operation of welding fume control equipment is affected by various factors including proper use and positioning of the equipment, maintenance of the equipment and the specific welding procedure and application involved. Worker exposure level should be checked upon installation and periodically thereafter to be certain it is within applicable OSHA PEL and ACGIH TLV limits.
- 5.c. Do not weld in locations near chlorinated hydrocarbon vapors coming from degreasing, cleaning or spraying operations. The heat and rays of the arc can react with solvent vapors to form phosgene, a highly toxic gas, and other irritating products.
- 5.d. Shielding gases used for arc welding can displace air and cause injury or death. Always use enough ventilation, especially in confined areas, to insure breathing air is safe.
- 5.e. Read and understand the manufacturer’s instructions for this equipment and the consumables to be used, including the material safety data sheet (MSDS) and follow your employer’s safety practices. MSDS forms are available from your welding distributor or from the manufacturer.
- 5.f. Also see item 1.b.

AUG 06

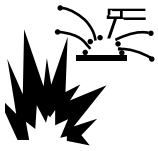

WELDING SPARKS can cause fire or explosion.

6.a. Remove fire hazards from the welding area. If this is not possible, cover them to prevent the welding sparks from starting a fire.

Remember that welding sparks and hot materials from welding can easily go through small cracks and openings to adjacent areas. Avoid welding near hydraulic lines. Have a fire extinguisher readily available.

- 6.b. Where compressed gases are to be used at the job site, special precautions should be used to prevent hazardous situations. Refer to "Safety in Welding and Cutting" (ANSI Standard Z49.1) and the operating information for the equipment being used.
- 6.c. When not welding, make certain no part of the electrode circuit is touching the work or ground. Accidental contact can cause overheating and create a fire hazard.
- 6.d. Do not heat, cut or weld tanks, drums or containers until the proper steps have been taken to insure that such procedures will not cause flammable or toxic vapors from substances inside. They can cause an explosion even though they have been "cleaned". For information, purchase "Recommended Safe Practices for the Preparation for Welding and Cutting of Containers and Piping That Have Held Hazardous Substances", AWS F4.1 from the American Welding Society (see address above).
- 6.e. Vent hollow castings or containers before heating, cutting or welding. They may explode.
- 6.f. Sparks and spatter are thrown from the welding arc. Wear oil free protective garments such as leather gloves, heavy shirt, cuffless trousers, high shoes and a cap over your hair. Wear ear plugs when welding out of position or in confined places. Always wear safety glasses with side shields when in a welding area.
- 6.g. Connect the work cable to the work as close to the welding area as practical. Work cables connected to the building framework or other locations away from the welding area increase the possibility of the welding current passing through lifting chains, crane cables or other alternate circuits. This can create fire hazards or overheat lifting chains or cables until they fail.
- 6.h. Also see item 1.c.
- 6.i. Read and follow NFPA 51B "Standard for Fire Prevention During Welding, Cutting and Other Hot Work", available from NFPA, 1 Batterymarch Park, PO box 9101, Quincy, Ma 022690-9101.
- 6.j. Do not use a welding power source for pipe thawing.

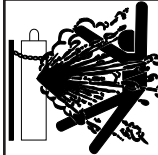

CYLINDER may explode if damaged.

7.a. Use only compressed gas cylinders containing the correct shielding gas for the process used and properly operating regulators designed for the gas and pressure used. All hoses, fittings, etc. should be suitable for the application and maintained in good condition.

- 7.b. Always keep cylinders in an upright position securely chained to an undercarriage or fixed support.
- 7.c. Cylinders should be located:
- Away from areas where they may be struck or subjected to physical damage.
 - A safe distance from arc welding or cutting operations and any other source of heat, sparks, or flame.
- 7.d. Never allow the electrode, electrode holder or any other electrically "hot" parts to touch a cylinder.
- 7.e. Keep your head and face away from the cylinder valve outlet when opening the cylinder valve.
- 7.f. Valve protection caps should always be in place and hand tight except when the cylinder is in use or connected for use.
- 7.g. Read and follow the instructions on compressed gas cylinders, associated equipment, and CGA publication P-1, "Precautions for Safe Handling of Compressed Gases in Cylinders," available from the Compressed Gas Association 1235 Jefferson Davis Highway, Arlington, VA 22202.



FOR ELECTRICALLY powered equipment.

- 8.a. Turn off input power using the disconnect switch at the fuse box before working on the equipment.
- 8.b. Install equipment in accordance with the U.S. National Electrical Code, all local codes and the manufacturer's recommendations.
- 8.c. Ground the equipment in accordance with the U.S. National Electrical Code and the manufacturer's recommendations.

Jan 07

PRÉCAUTIONS DE SÛRETÉ

Pour votre propre protection lire et observer toutes les instructions et les précautions de sûreté spécifiques qui paraissent dans ce manuel aussi bien que les précautions de sûreté générales suivantes:

Sûreté Pour Soudage A L'Arc

1. Protégez-vous contre la secousse électrique:
 - a. Les circuits à l'électrode et à la pièce sont sous tension quand la machine à souder est en marche. Eviter toujours tout contact entre les parties sous tension et la peau nue ou les vêtements mouillés. Porter des gants secs et sans trous pour isoler les mains.
 - b. Faire très attention de bien s'isoler de la masse quand on soude dans des endroits humides, ou sur un plancher métallique ou des grilles métalliques, principalement dans les positions assis ou couché pour lesquelles une grande partie du corps peut être en contact avec la masse.
 - c. Maintenir le porte-électrode, la pince de masse, le câble de soudage et la machine à souder en bon et sûr état de fonctionnement.
 - d. Ne jamais plonger le porte-électrode dans l'eau pour le refroidir.
 - e. Ne jamais toucher simultanément les parties sous tension des porte-électrodes connectés à deux machines à souder parce que la tension entre les deux pinces peut être le total de la tension à vide des deux machines.
 - f. Si on utilise la machine à souder comme une source de courant pour soudage semi-automatique, ces précautions pour le porte-électrode s'appliquent aussi au pistolet de soudage.
2. Dans le cas de travail au dessus du niveau du sol, se protéger contre les chutes dans le cas où on reçoit un choc. Ne jamais enrouler le câble-électrode autour de n'importe quelle partie du corps.
3. Un coup d'arc peut être plus sévère qu'un coup de soleil, donc:
 - a. Utiliser un bon masque avec un verre filtrant approprié ainsi qu'un verre blanc afin de se protéger les yeux du rayonnement de l'arc et des projections quand on soude ou quand on regarde l'arc.
 - b. Porter des vêtements convenables afin de protéger la peau de soudeur et des aides contre le rayonnement de l'arc.
 - c. Protéger l'autre personnel travaillant à proximité au soudage à l'aide d'écrans appropriés et non-inflammables.
4. Des gouttes de laitier en fusion sont émises de l'arc de soudage. Se protéger avec des vêtements de protection libres de l'huile, tels que les gants en cuir, chemise épaisse, pantalons sans revers, et chaussures montantes.
5. Toujours porter des lunettes de sécurité dans la zone de soudage. Utiliser des lunettes avec écrans latéraux dans les zones où l'on pique le laitier.

6. Eloigner les matériaux inflammables ou les recouvrir afin de prévenir tout risque d'incendie dû aux étincelles.
7. Quand on ne soude pas, poser la pince à un endroit isolé de la masse. Un court-circuit accidentel peut provoquer un échauffement et un risque d'incendie.
8. S'assurer que la masse est connectée le plus près possible de la zone de travail qu'il est pratique de le faire. Si on place la masse sur la charpente de la construction ou d'autres endroits éloignés de la zone de travail, on augmente le risque de voir passer le courant de soudage par les chaînes de levage, câbles de grue, ou autres circuits. Cela peut provoquer des risques d'incendie ou d'échauffement des chaînes et des câbles jusqu'à ce qu'ils se rompent.
9. Assurer une ventilation suffisante dans la zone de soudage. Ceci est particulièrement important pour le soudage de tôles galvanisées plombées, ou cadmiées ou tout autre métal qui produit des fumées toxiques.
10. Ne pas souder en présence de vapeurs de chlore provenant d'opérations de dégraissage, nettoyage ou pistolage. La chaleur ou les rayons de l'arc peuvent réagir avec les vapeurs du solvant pour produire du phosgène (gas fortement toxique) ou autres produits irritants.
11. Pour obtenir de plus amples renseignements sur la sûreté, voir le code "Code for safety in welding and cutting" CSA Standard W 117.2-1974.

PRÉCAUTIONS DE SÛRETÉ POUR LES MACHINES À SOUDER À TRANSFORMATEUR ET À REDRESSEUR

1. Relier à la terre le châssis du poste conformément au code de l'électricité et aux recommandations du fabricant. Le dispositif de montage ou la pièce à souder doit être branché à une bonne mise à la terre.
2. Autant que possible, l'installation et l'entretien du poste seront effectués par un électricien qualifié.
3. Avant de faire des travaux à l'intérieur de poste, la débrancher à l'interrupteur à la boîte de fusibles.
4. Garder tous les couvercles et dispositifs de sûreté à leur place.

Mar. '93

Thank You

for selecting a **QUALITY** product by Lincoln Electric. We want you to take pride in operating this Lincoln Electric Company product
... as much pride as we have in bringing this product to you!

CUSTOMER ASSISTANCE POLICY

The business of The Lincoln Electric Company is manufacturing and selling high quality welding equipment, consumables, and cutting equipment. Our challenge is to meet the needs of our customers and to exceed their expectations. On occasion, purchasers may ask Lincoln Electric for advice or information about their use of our products. We respond to our customers based on the best information in our possession at that time. Lincoln Electric is not in a position to warrant or guarantee such advice, and assumes no liability, with respect to such information or advice. We expressly disclaim any warranty of any kind, including any warranty of fitness for any customer's particular purpose, with respect to such information or advice. As a matter of practical consideration, we also cannot assume any responsibility for updating or correcting any such information or advice once it has been given, nor does the provision of information or advice create, expand or alter any warranty with respect to the sale of our products.

Lincoln Electric is a responsive manufacturer, but the selection and use of specific products sold by Lincoln Electric is solely within the control of, and remains the sole responsibility of the customer. Many variables beyond the control of Lincoln Electric affect the results obtained in applying these types of fabrication methods and service requirements.

Subject to Change – This information is accurate to the best of our knowledge at the time of printing. Please refer to www.lincolnelectric.com for any updated information.

Please Examine Carton and Equipment For Damage Immediately

When this equipment is shipped, title passes to the purchaser upon receipt by the carrier. Consequently, Claims for material damaged in shipment must be made by the purchaser against the transportation company at the time the shipment is received.

Please record your equipment identification information below for future reference. This information can be found on your machine nameplate.

Product _____

Model Number _____

Code Number or Date Code _____

Serial Number _____

Date Purchased _____

Where Purchased _____

Whenever you request replacement parts or information on this equipment, always supply the information you have recorded above. The code number is especially important when identifying the correct replacement parts.

On-Line Product Registration

- Register your machine with Lincoln Electric either via fax or over the Internet.
 - For faxing: Complete the form on the back of the warranty statement included in the literature packet accompanying this machine and fax the form per the instructions printed on it.
 - For On-Line Registration: Go to our **WEB SITE** at www.lincolnelectric.com. Choose "Quick Links" and then "Product Registration". Please complete the form and submit your registration.

Read this Operators Manual completely before attempting to use this equipment. Save this manual and keep it handy for quick reference. Pay particular attention to the safety instructions we have provided for your protection. The level of seriousness to be applied to each is explained below:

WARNING

This statement appears where the information **must** be followed **exactly** to avoid **serious personal injury** or **loss of life**.

CAUTION

This statement appears where the information **must** be followed to avoid **minor personal injury** or **damage to this equipment**.

	Page
Installation	Section A
Technical Specifications	A-1
Safety Precautions	A-2
Mounting the Wire Drive Unit	A-2
Electrode Routing.....	A-2
Electrode and Work Cable Connections	A-2
Negative Electrode Polarity.....	A-3
Shielding Gas Connection.....	A-3
Control Cable	A-3
Control Cable Connections	A-3
Control Cable Specifications	A-4
Wire Drive Gear Ratio (High or Low Speed).....	A-4
Selecting the Proper Gear Ratio	A-4
Changing the Wire Drive Ratio.....	A-5
Wire Feed Drive Roll Kits.....	A-6
Procedure to Install Drive Rolls and Wire Guides	A-6
Drive Roll Kit Installation (KP1505-[]),(KP1507-[])	A-6
General Gun Connection Guidelines	A-6
Gun Receiver Bushings and Adapters	A-7
Conduit Adapters	A-7
Remote Sense Lead Specifications	A-7
Installation of Field Installed Options	A-7
Feeding Electrode and Brake Adjustment.....	A-8
Drive Roll Pressure Setting	A-8
<hr/>	
Operation	Section B
Safety Precautions	B-1
Duty Cycle.....	B-1
General Description	B-1
Recommended Processes	B-1
Process Limitations	B-1
Recommended Equipment / Interface.....	B-1
<hr/>	
Accessories	Section C
Optional Equipment.....	C-1
Drive Roll and Guide Tube Kits	C-1
<hr/>	
Maintenance	Section D
Safety Precautions	D-1
Routine Maintenance	D-1
Drive Rolls and Guide Tubes	D-1
Avoiding Wire Feeding Problems.....	D-1
Periodic Maintenance	D-1
Procedure for Removing Feedplate from Wire Feeder	D-1
<hr/>	
Troubleshooting	Section E
Safety Precautions	E-1
Troubleshooting Guide	E-2 thru E-4
<hr/>	
Diagrams	Section F
Wiring Diagram	F-1
Dimension Print.....	F-2
<hr/>	
Parts Lists	P-381 Series

TECHNICAL SPECIFICATIONS – Power Feed 10 Robotic-K1780-1

WIRE DRIVE OR WIRE DRIVE SECTION OF FEEDER							
SPEC.#	TYPE	LOW SPEED RATIO			HIGH SPEED RATIO		
		Speed	Wire Size		Speed	Wire Size	
	Solid		Cored			Solid	Cored
K1780-1	Power Feed 10	50-800 IPM (1.27-20.3 m/m)	.025 - 3/32 in. (0.6 - 2.4 mm)	.035 - .120 in. (0.9 - 3.2 mm)	75 - 1200 IPM (2.03 - 30.5 m/m)	.025 - 1/16 in. (0.6 - 1.6 mm)	.035 - 5/64 in. (0.9 - 2.0 mm)

CONTROL BOX, WIRE DRIVE AND COMPLETE UNITS								
SPEC.#	TYPE	INPUT POWER	PHYSICAL SIZE			TEMPERATURE RATING		
			Dimensions			Weight	Operating	Storage
			Height	Width	Depth			
K1780-1	Power Feed 10 Wire Feeder	40 VDC	13.5 " (340 mm)	10.3 " (261 mm)	12.0 " (304 mm)	23.5 Lbs (10.7 Kg)	-20° to +40° C	-40° to +40° C

POWER FEED 10 / R



SAFETY PRECAUTIONS

⚠ WARNING



ELECTRIC SHOCK can kill.

- Only qualified personnel should perform this installation.
- Turn off the input power to the power source at the disconnect switch or fuse box before working on this equipment. Turn off the input power to any other equipment connected to the welding system at the disconnect switch or fuse box before working on this equipment.
- Do not touch electrically hot parts.
- Always connect the Power Wave grounding lug (located inside the reconnect input access door) to a proper safety (Earth) ground.

MOUNTING OF THE PF10/R

Mount the wire drive unit by means of the 4 holes in the bottom of the wire drive base. Note that the gearbox assembly is electrically "hot" when welding. Therefore, make certain the gearbox does not come in contact with the structure on which the unit is mounted. The wire feed unit should be mounted so that the drive rolls are in a vertical plane to prevent the accumulation of dirt in the drive roll area. Do not bend the conduit more than 45°.

FIGURE A.1

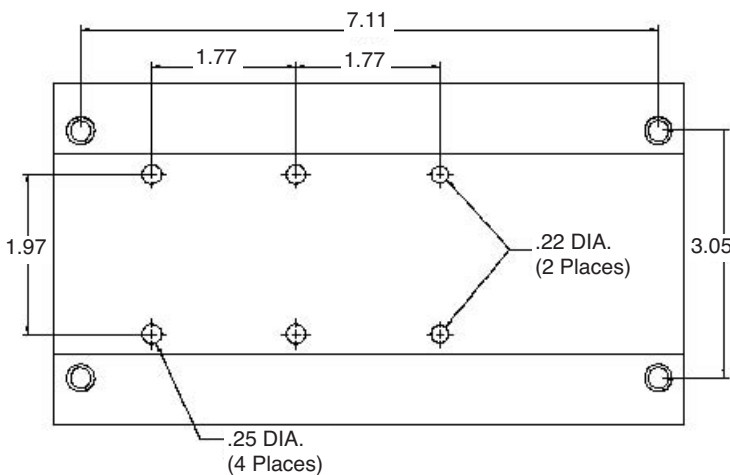

ELECTRODE ROUTING

The electrode supply may be either from reels, Readi-Reels, spools, or bulk packaged drums or reels. Observe the following precautions:

- Do not bend the conduit more than 45°, and to use the minimum amount of conduit necessary for the wire reel to connect to the wire feeder.
- The electrode is "hot" while welding and must be insulated from the boom, conduit and wire payoff structure.
- If more than one wire feed unit shares the same boom and are not sharing the same power source output stud, their wire and reels must be insulated from each other as well as insulated from their mounting structure.

ELECTRODE AND WORK CABLE CONNECTIONS

Most welding applications run with the electrode being positive (+). For those applications, connect the electrode cable between the wire feeder and the positive (+) output stud on the power source (located beneath the spring loaded output cover near the bottom of the case front).

A work lead must be run from the negative (-) power source output stud to the work piece. The work piece connection must be firm and secure, especially if pulse welding is planned. Excessive voltage drops at the work piece connection often result in unsatisfactory pulse welding performance.

Connect a work lead of sufficient size and length (per TABLE 1) between the proper output terminal on the power source and the work. Be sure the connection to the work makes tight metal-to-metal electrical contact. To avoid interference problems with other equipment and to achieve the best possible operation, route all cables directly to the work or wire feeder. Do not bundle the electrode and work leads tightly together. Avoid excessive lengths and do not coil excess cable.

Use K1796 Coaxial welding cables wherever possible.

Minimum work and electrode cables sizes are as follows:

TABLE 1

MINIMUM COPPER WORK CABLE SIZE, AWG	
Current (60% Duty Cycle)	Up To-100 Ft. Length (30 m)
400 Amps	2/0 (67 mm ²)
500 Amps	3/0 (85 mm ²)
600 Amps	3/0 (85 mm ²)

When using an inverter type power source, Use the largest welding (electrode and work) cables that are practical. At least 2/0 copper wire - even if the average output current would not normally require it. When pulsing, the pulse current can reach very high levels. Voltage drops can become excessive, leading to poor welding characteristics, if undersized welding cables are used.

Connect the one end of the electrode cable, to the power source output terminal of the desired polarity. Connect the other end of the electrode cable to the wire drive feed plate using the stud, lockwasher, and nut provided on the wire drive feed plate. The electrode cable lug must be against the feed plate. Be sure the connection to the feed plate makes tight metal-to-metal electrical contact. The electrode cable should be sized according to the specifications given in the work cable connections section.

NEGATIVE ELECTRODE POLARITY

When negative electrode polarity is required, such as in some Innershield applications, reverse the output connections at the power source (electrode cable to the negative (-) stud, and work cable to the positive (+) stud).

When operating with electrode polarity negative the switch 7 must be set to OFF.

Set the Negative Polarity switch on Wire Feed Head PC board as follows: **These instructions apply to the Power Wave 455/R and Power Wave 655/R.** Consult the manual for the power source if necessary.

⚠ WARNING

1. Turn off power to the power source at the disconnect switch.

2. Remove the front cover from the power source.

3. The wire feed head board is on the right side of the power source. Locate the 8-position DIP switch and look for switch 7 of the DIP switch.

4. Using a pencil or other small object, slide the switch to the ON position for negative electrode polarity. Conversely, slide the switch to the OFF position for positive electrode polarity.

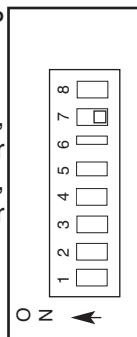

5. Replace the cover and screws. The PC board will “read” the switch at power up, automatically adjusting all control parameters for the speed range selected.

SHIELDING GAS CONNECTION

⚠ WARNING

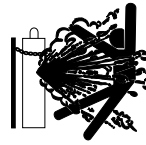

CYLINDER may explode if damaged.

- Keep cylinder upright and chained to support.
- Keep cylinder away from areas where it may be damaged.
- Never lift welder with cylinder attached.
- Never allow welding electrode to touch cylinder.



• Keep cylinder away from welding or other live electrical circuits.

BUILDUP OF SHIELDING GAS may harm health or kill.

• Shut off shielding gas supply when not in use.

SEE AMERICAN NATIONAL STANDARD Z-49.1, “SAFETY IN WELDING AND CUTTING” PUBLISHED BY THE AMERICAN WELDING SOCIETY.

The customer must provide a cylinder of shielding gas, a pressure regulator, a flow control valve, and a hose from the flow valve to the gas inlet fitting of the wire drive unit.

Connect a supply hose from the gas cylinder flow valve outlet to the 5/8-18 female inert gas fitting on the back panel of the wire drive or, if used, on the inlet of the Gas Guard regulator.

CONTROL CABLE

CONTROL CABLE CONNECTIONS

The Power Wave / Power Feed Wire Feeders offer flexibility in the connection of system components. This system uses the same type of control cable between all of the system components. Connections can be “daisy chained” from one system component to another. Components can be connected in any order, as long as the proper input and output receptacles are present.

Connect the control cable from the Power Feed 10 Robotic Wire Drive to the output receptacle on the PowerWave.

NOTE: The maximum cable length between the Power Feed 10 Robotic and the power source is 100 feet (33 m).

CONTROL CABLE SPECIFICATIONS

It is recommended that genuine Lincoln control cables be used at all times. Lincoln cables are specifically designed for the communication and power needs of the Power Wave / Power Feed system. The use of non-standard cables, especially in lengths greater than 25 feet, can lead to communication problems (system shutdowns), poor motor acceleration (poor arc starting) and low wire driving force (wire feeding problems).

Lincoln control cables are copper 22 conductor cable in a SO-type rubber jacket.

TABLE 2 (CONNECTOR WIRING)

Pin	Lead #	Function
A	841	+15vdc Tach voltage
B	844	Tach common
C	842	Tach 1A differential signal
D	843	Tach 1B differential signal
E	845	Tach 2A differential signal
F	846	Tach 2B differential signal -
G	847	Single Tach Input
H		Reserved for future use
I	67B	Voltage sense lead
J	539	Motor "+"
K	541	Motor "-"
L		Reserved for future use
M		Reserved for future use
N	521	+40vdc for solenoid
P	522	solenoid input
R		Reserved for future use
S		Reserved for future use
T	855A	Shield ground to case
U		Reserved for future use
V		Reserved for future use
W		Reserved for future use
X		Reserved for future use

AVAILABLE CABLE ASSEMBLIES:

K1795 Control cable only. Available in lengths of 25', 50' and 100'.

WIRE DRIVE GEAR RATIO (HIGH OR LOW SPEED)

The speed range capability and drive torque of the Power Feed wire drives can be easily and quickly changed by changing the external drive gear. The Power Feed Wire Feeders are shipped with both high speed and a low speed gears. As shipped from the factory, the low speed (high torque) gear is installed on the feeder. If this is the desired gear ratio, no changes need be made.

SELECTING THE PROPER GEAR RATIO

See Specification Section A-1 for feed speed and wire size capabilities with high and low speed gear ratios. To determine whether you should be using the high or low speed ratio use the following guidelines:

- If you need to operate at wire feed speeds above 800 IPM (20 m/m), you will need to install the high speed gear (large 30 tooth, 1.6 inch diameter gear).
- If you do not need to run at wire feed speeds in excess of 800 IPM (20 m/m), you should use the low speed gear (small, 20 tooth, 1.1 inch diameter gear). Using the low speed ratio will provide the maximum available wire driving force.

The full range of wire feed speed listed in Section A-1 may not be useable for all welding programs. Check your welding software to make sure the desired WFS falls within the welding software limits.

CHANGING THE WIRE DRIVE RATIO

WARNING



ELECTRIC SHOCK can kill.

- Turn off power to the power source at the disconnect switch.

Changing the ratio requires a gear change and a PC board switch change. The Power Feed Wire Feeders are shipped with both high speed and a low speed gears. As shipped from the factory, the low speed (high torque) gear is installed on the feeder. For identification purposes, the low speed (high torque) gear has 20 teeth and is 1.1 inches in diameter. The high speed gear has 30 teeth and is 1.6 inches in diameter.

1. Pull open the Pressure Door.
2. Remove the Phillips head screw retaining the pinion gear to be changed and remove the gear. If the gear is not easily accessible or difficult to remove, remove or adjust feed plate from the gearbox. To remove feed plate:
 - Loosen the clamping collar screw using a 3/16" Allen wrench. The clamping collar screw is accessed from the bottom of the feed plate. It is the screw which is perpendicular to the feeding direction.
 - Loosen the retaining screw, which is also accessed from bottom of feeder, using a 3/16" Allen wrench. Continue to loosen the screw until the feed plate can be easily pulled off of the wire feeder.
3. Loosen, but do not remove, the screw on the lower right face of the feed plate with a 3/16" Allen wrench.
4. Remove the screw on the left face of the feed plate. If changing from high speed (larger gear) to low speed (smaller gear), line the lower hole on the left face of the feed plate with the threads on the clamping collar. Line the upper hole with the threads to install larger gear for high speed feeder. If feed plate does not rotate to allow holes to line up, further loosen the screw on right face of feed plate.

5. Remove the small gear from the output shaft. Lightly cover the output shaft with engine oil or equivalent. Install gear onto output shaft and secure with flat washer, lock washer, and Phillips head screw which were previously removed.
6. Tighten the screw on lower right face of feed plate.
7. Re-attach feed plate to wire feeder if removed in Step 2.
8. Feed plate will be rotated out-of-position due to the gear change. Adjust the angle of the feed plate per Item 2.

Set the High/Low switch code on Wire Drive PC board which is located on the **Power Wave 455/R** and **Power Wave 655/R**. Consult the Instruction Manual for proper power source settings.

WIRE FEED DRIVE ROLL KITS

NOTE: The maximum rated solid and cored wire sizes and selected drive ratios are shown on the SPECIFICATIONS in the front of this section.

The electrode sizes that can be fed with each roll and guide tube are stenciled on each part. Check the kit for proper components. Kit specifications can be found in the ACCESSORIES section.

PROCEDURE TO INSTALL DRIVE ROLLS AND WIRE GUIDES

⚠ WARNING



ELECTRIC SHOCK can kill.

- Do not touch electrically live parts such as output terminals or internal wiring.
- When feeding without Power Feed 10 “Cold Feed” feature, electrode and drive mechanism are “hot” to work and ground and could remain energized several seconds after the gun trigger is released.
- Turn OFF input power at welding power source before installation or changing drive roll and/or guide tubes.
- Welding power source must be connected to system ground per the National Electrical Code or any applicable local codes.
- Only qualified personnel should perform this installation.

Observe all additional Safety Guidelines detailed throughout this manual.

DRIVE ROLL KIT INSTALLATION (KP1505-[])* (KP1507-[])*

⚠ WARNING

1. Turn OFF Welding Power Source.
2. Pull open Pressure Door to expose rolls and wire guides.
3. Remove Outer Wire Guide by turning knurled thumb screws counter-clock-wise to unscrew them from Feedplate.
4. Remove drive rolls, if any are installed, by pulling straight off shaft. Remove inner guide.
5. Insert inner Wire Guide, groove side out, over the two locating pins in the feedplate.

6. Install each drive roll by pushing over shaft until it butts up against locating shoulder on the drive roll shaft. (Do Not exceed maximum wire size rating of the wire drive).
7. Install Outer Wire Guide by sliding over locating pins and tightening in place.
8. Engage upper drive rolls if they are in the “open” position and close Pressure Door.

TO SET DRIVE ROLL PRESSURE, see “Drive Roll Pressure Setting” in OPERATION.

GENERAL GUN CONNECTION GUIDELINES

The instructions supplied with the gun and K1500 series gun adapter should be followed when installing and configuring a gun. The following guidelines are general procedures only that are not intended to cover all guns.

1. Check that the drive rolls and guide tubes are proper for the electrode size and type being used.
2. Lay the cable out straight. Insert the connector on the welding conductor cable into the brass conductor block on the front of the wire drive head. Make sure it is all the way in and tighten the hand clamp. Keep this connection clean and bright.

Note: For Fast-Mate and European connector style guns, connect gun to gun connector making sure all pins and gas tube line up with appropriate holes in connector. Tighten gun by turning the large nut on gun clockwise.

3. For GMA Gun Cables with separate gas fittings, connect the gas hose from the wire drive unit to the gun cable barbed fitting.

*See ACCESSORIES SECTION Table C.1, page C-1.

GUN RECEIVER BUSHINGS AND ADAPTERS

The Power Feed wire feeders are equipped with factory installed K1500-2 gun connection kits. These kits are for guns having a Tweco #2-#4 type connector. The Power Feed 10/R has been designed to make connecting a variety of guns easy and inexpensive with the K1500 series of gun connection kits.

Non-Lincoln Guns

Most competitive guns can be connected to the Power Feed 10/R by using one of the K1500 series adapter kits, See "Gun Adapters" in ACCESSORIES section.

K489-7 (Dual Schedule Fast-Mate Adapter)

This adapter installs directly into the wire drive feed-plate, to provide for use of guns with Fast-Mate or European style gun connections. This K489-7 will handle both standard Fast-Mate and Dual Schedule Fast-Mate guns.

K1500-1 (Lincoln Innershield gun standard connection)

Use this kit to connect the following guns: Guns having a Lincoln standard innershield gun connector, Magnum 200/300/400 with K466-1 connector kit, and Magnum 550 guns with the K613-1 gun connection kit.

K1500-2 (Tweco #2-#4 type connection)

The K1500-2 gun adapter comes factory installed on the Power Feed 10/R wire feeder. Use this adapter for guns that have a Tweco #2-#4 connector. Such guns include Magnum 200/300/400 guns with K466-2 connector kit, and completely factory assembled Magnum guns that are factory equipped with the K466-2 connector (such as the K471-21, -22, and -23 dedicated Magnum 400 guns and the K497-20 and -21 Magnum 200 guns).

K1500-3 (Tweco #5 connection)

For Magnum 550 gun with K613-2 Connection Kit, and any other gun having a Tweco #5 connector .

K1500-4 (Miller connection)

For any gun having a newer style Miller connector. Install gun adapters per the instructions shipped with it.

K1500-5 (Oxo connection)

For any gun having an Oxo style threaded connector. Install gun adapter per the instructions shipped with it.

CONDUIT ADAPTERS

The K1546-1 and K1546-2 Adapter for use with Lincoln Magnum conduit (K515 or 565) and E-Beam conduit. The K1546-1 is to be used for wire sizes (.023 - 1/16), K1546-2 is to be used for wire sizes (1/16 - .120)

For Magnum conduit:

Install the K1546-1 or K1546-2 adapter at the incoming end of the feed plate, secure with the set screw located at the back of the feed plate. If a brass fitting is supplied with the conduit, remove it from the feeder end of the conduit by unscrewing it. Insert the conduit into the K1546-1 or K1546-2, secure the conduit by fastening it the adapter with the supplied knob screw.

For E-Beam Conduit:

Install the K1546-2 gun adapter at the incoming end of the feed plate, secure with the set screw located at the back of the feed plate. Insert the conduit into the K1546-2, secure the conduit by fastening it the adapter with the supplied knob screw.

REMOTE SENSE LEAD SPECIFICATIONS

The Power Feed10/R should always be operated with the voltage sense lead (67) attached to the feed plate.

INSTALLATION OF FIELD INSTALLED OPTIONS

Water Flow Sensor

Water cooled guns can be damaged very quickly if they are used even momentarily without water flowing. Recommend practice is to install a water flow sensor on the water return line of the torch. When fully integrated into the welding system, the sensor will prevent welding if no water flow is present.

Gas Guard Regulator

The Gas Guard regulator is available as an optional accessory (K659-1) for Power Feed Robotic wire drive unit. Install the 5/8-18 male outlet of the regulator to the proper 5/8-18 female gas inlet on the back panel of the wire drive. Secure fitting with flow adjuster key at top.

Feeding Electrode and Brake Adjustment

1. Turn the Reel or spool until the free end of the electrode is accessible. If using a drum or large reel, supply the electrode to the PF-10/R with an electrode conduit. Minimize the number of bends in the conduit and the distance the electrode must travel.
2. While tightly holding the electrode, cut off the bent end and straighten the first 6" (150 mm). Cut off the first 1" (25 mm). (If the electrode is not properly straightened, it may not feed or may jam causing a "bird nest".)
3. Insert the free end through the incoming guide tube.
4. Activate the Cold Inch mode until the the drive rolls grab the electrode.
3. If the only result is drive roll slippage, disengage the gun, pull the gun cable forward about 6" (150 mm). There should be a slight waviness in the exposed wire. If there is no waviness, the pressure is too low. Increase the pressure setting 3 turns, reconnect the gun, tighten locking clamp and repeat the above steps.

WARNING

When feeding with the trigger, unless "Cold Feed" trigger mode is selected the electrode and drive mechanism are always "Hot" to work and ground and could remain "Hot" several seconds after the Gun trigger is released.

5. Feed the electrode through the gun.
6. Adjust the brake tension with the thumbscrew on the spindle hub, until the reel turns freely but with little or no overrun when wire feeding is stopped. Do not over tighten.

Drive Roll Pressure Setting

The Power Feed 10/R drive roll pressures are factory pre-set to about position "2" as shown on the pressure indicator on the front of the feed plate door. This is an approximate setting.

The optimum drive roll pressure varies with type of wire, surface condition, lubrication, and hardness. Too much pressure could cause "bird nesting," but too little pressure could cause wire feed slippage with load and / or acceleration. The optimum drive roll setting can be determined as follows:

1. Press end of gun against a solid object that is electrically isolated from the welder output and press the gun trigger for several seconds.
2. If the wire "bird nests", jams, or breaks at the drive roll, the drive roll pressure is too great. Back the pressure setting out 2 turns, run new wire through gun, and repeat above steps.

SAFETY INSTRUCTIONS

Read and understand this entire section of operating instructions before operating the machine.



WARNING

ELECTRIC SHOCK can kill.



- Unless using cold feed feature, when feeding with gun trigger, the electrode and drive mechanism are always electrically energized and could remain energized several seconds after the welding ceases.
- Do not touch electrically live parts or electrodes with your skin or wet clothing.
- Insulate yourself from the work and ground.
- Always wear dry insulating gloves.

FUMES AND GASES can be dangerous.



- Keep your head out of fumes.
- Use ventilation or exhaust to remove fumes from breathing zone.

WELDING SPARKS can cause fire or explosion.



- Keep flammable material away.
- Do not weld on containers that have held combustibles.

ARC RAYS can burn.



- Wear eye, ear, and body protection.

Observe additional Safety Guidelines detailed in the beginning of this manual.

DUTY CYCLE

The Power Feed wire feeders are capable of welding at a 100% duty cycle (continuous welding). The power source will be the limiting factor in determining system duty cycle capability.

GENERAL DESCRIPTION

The Power Feed 10 Robotic is a high performance, digitally controlled, modular wire feeder. Properly equipped, it can support the GMAW, GMAW-P and FCAW processes. The Power Feed wire feeders are designed to be a part of a modular, multi-process welding system. The Power Feed 10 Robotic is a 4 driven roll feeder that operates on 40VDC input power.

The Power Feed Robotic wire feeders are designed to be used with Robotic PowerWaves. Close integration of the feeder, power source and customer's equipment creates the foundation for a system with superior welding performance.

The Power Feed 10 Robotic is intended for automatic applications. It specifically designed to mount to a robot arm or to use in hard automation applications.

Operation for the Power Feed 10 Robotic is with a Power Feed compatible robotic power source.

RECOMMENDED PROCESSES

The Power Feed Wire Feeders can be set up in a number of configurations. They are designed to be used for GMAW, GMAW-P and FCAW for a variety of materials, including mild steel, stainless steel, and cored wires.

PROCESS LIMITATIONS

The feeders are capable of handling only some submerged arc applications.

RECOMMENDED EQUIPMENT/INTERFACE

The Power Feed Robotic Feeders must be used with PowerWave 455/R, PowerWave 655/R or other Robotic PowerWave source. These are the only power source to supply the correct operating voltage (40 volts DC) and communication method (Arc-Link digital communications) required by the Power Feed 10 Robotic.

OPTIONAL EQUIPMENT

- KP1505 Drive Roll and Wire Guide Kits
- KP1507 Drive Roll and Wire Guide Kits

The KP1507 series of drive roll kits contain a number of components, in addition to the drive rolls, to optimize the wire feeder for aluminum feeding. These components are specifically designed to protect the aluminum wire from abrasion and deformation, thereby avoiding many common aluminum feeding problems.

- K1546 Conduit

PLATFORM COMMONALITIES

- Power Feed 10 series Feedhead.
- CGA gas connections.
- Quick connect water connections.
- Works with all PowerWave ArcLink systems. "It is not compatible with the PowerWave 350, 450 or 500 or Linc-net PowerWave 455's"

OPERATIONAL FEATURES AND CONTROLS

- All procedure settings for the Power Feed 10 Robotic wire feeder is through software control. A DIP switch is used to indicate hardware settings.

TABLE C.1 – DRIVE ROLL AND GUIDE TUBE KITS

Wire Size		
<u>Solid Steel Electrode</u>		<u>KP No. Series</u>
0.023" - 0.025"	(0.6 mm)	KP1505 - 030S
0.030"	(0.8 mm)	KP1505 - 030S
0.035"	(0.9 mm)	KP1505 - 035S
0.040"	(1.0 mm)	KP1505 - 045S
0.045"	(1.2 mm)	KP1505 - 045S
0.052"	(1.4 mm)	KP1505 - 052S
1/16"	(1.6 mm)	KP1505 - 1/16S
5/64"	(2.0 mm)	KP1505-5/64
3/32"	(2.4 mm)	KP1505-3/32
<u>Cored Electrode</u>		
0.030	(0.8 mm)	KP1505 - 035C
0.035"	(0.9 mm)	KP1505 - 035C
0.040"	(1.0 mm)	KP1505 - 045C
0.045"	(1.2 mm)	KP1505 - 045C
0.052"	(1.4 mm)	KP1505 - 052C
1/16"	(1.6 mm)	KP1505 - 1/16C
0.068"	(1.7 mm)	KP1505 - 068
5/64"	(2.0 mm)	KP1505 - 5/64
3/32"	(2.4 mm)	KP1505 - 3/32
7/64" Lincore Hard Facing	(2.8mm)	KP1505 - 7/64H
7/64"	(2.8mm)	KP1505 - 7/64
.120"	(3.0mm)	KP1505 - 120
<u>Aluminum Electrode</u>		
0.035"	(0.9 mm)	KP1507 - 035A
0.040"	(1.0 mm)	KP1507 - 040A
3/64"	(1.2 mm)	KP1507 - 3/64A
1/16"	(1.6 mm)	KP1507 - 1/16A
3/32"	(2.2 mm)	KP1507 - 3/32A

POWER FEED 10 / R



SAFETY PRECAUTIONS

WARNING



ELECTRIC SHOCK can kill.

- Do not touch electrically live parts such as output terminals or internal wiring.
- When inching with gun trigger, electrode and drive mechanism are “hot” to work and ground and could remain energized several seconds after the gun trigger is released.
- Turn OFF input power at welding power source before installation or changing drive roll and/or guide tubes.
- Welding power source must be connected to system ground per the National Electrical Code or any applicable local codes.
- Only qualified personnel should perform maintenance work.

Observe all additional Safety Guidelines detailed throughout this manual.

ROUTINE MAINTENANCE

Drive Rolls and Guide Tubes

After feeding every coil of wire, inspect the feed plate and drive rolls. Clean them as necessary.

All drive rolls have two identical grooves. The rolls may be flipped over to use the other groove.

See “Procedure to Install Drive Rolls and Wire Guides” in the INSTALLATION section for roll changing instructions.

AVOIDING WIRE FEEDING PROBLEMS

Wire feeding problems can be avoided by observing the following gun handling and feeder set up procedures:

- a) Do not bend the conduit more than 45°.
- b) Keep the minimum amount of conduit necessary for the wire reel to connect to the wire feeder.
- c) Do not allow dolly wheels or trucks to run over cables.
- d) Keep cable clean by following maintenance instructions.
- e) Use only clean, rust-free electrode. The Lincoln electrodes have proper surface lubrication.
- f) Replace contact tip when the arc starts to become unstable or the contact tip end is fused or deformed.
- g) Do not use excessive wire spindle brake settings.
- h) Use proper drive rolls, wire guides and drive roll pressure settings.

PERIODIC MAINTENANCE

Wire Drive Motor and Gearbox

Every year inspect the gearbox and coat the gear teeth with a moly-disulfide filled grease. **Do not** use graphite grease.

Every six months check the motor brushes. Replace them if they are less than 1/4” long.

HOW TO USE TROUBLESHOOTING GUIDE

WARNING

Service and Repair should only be performed by Lincoln Electric Factory Trained Personnel. Unauthorized repairs performed on this equipment may result in danger to the technician and machine operator and will invalidate your factory warranty. For your safety and to avoid Electrical Shock, please observe all safety notes and precautions detailed throughout this manual.

This Troubleshooting Guide is provided to help you locate and repair possible machine malfunctions. Simply follow the three-step procedure listed below.

Step 1. LOCATE PROBLEM (SYMPTOM).

Look under the column labeled “PROBLEM (SYMPTOMS)”. This column describes possible symptoms that the machine may exhibit. Find the listing that best describes the symptom that the machine is exhibiting.

Step 2. POSSIBLE CAUSE.

The second column labeled “POSSIBLE CAUSE” lists the obvious external possibilities that may contribute to the machine symptom.

Step 3. RECOMMENDED COURSE OF ACTION

This column provides a course of action for the Possible Cause, generally it states to contact your local Lincoln Authorized Field Service Facility.

If you do not understand or are unable to perform the Recommended Course of Action safely, contact your local Lincoln Authorized Field Service Facility.

CAUTION

If for any reason you do not understand the test procedures or are unable to perform the tests/repairs safely, contact your **Local Lincoln Authorized Field Service Facility** for technical troubleshooting assistance before you proceed.

Observe all Safety Guidelines detailed throughout this manual

PROBLEMS (SYMPTOMS)	POSSIBLE CAUSE	RECOMMENDED COURSE OF ACTION
Rough wire feeding or wire not feeding but drive rolls are turning.	<ol style="list-style-type: none"> 1. Gun cable kinked and / or twisted. 2. Wire jammed in gun and cable. Check for mechanical restrictions in feeding path. 3. Check for current position of drive rolls relative to split wire guide groove. 4. Drive rolls may not be seated properly. 5. Gun cable dirty, clean if necessary. 6. Worn drive roll. 7. Electrode rusty and/or dirty. Cable frayed, or poor solder joint at work or electrode lug. 8. Worn nozzle or cable liner. Replace if necessary. 9. Partially flashed or melted contact tip. Replace if necessary. 10. Incorrect drive roll pressure. Readjust if necessary. 11. Improper liner, tip or inner / outer guides. Replace if necessary. 12. Incorrect wire drive or gear ratio selection on the control P.C. board. 	<p>If all recommended possible areas of misadjustment have been checked and the problem persists, Contact your local Lincoln Authorized Field Service Facility.</p>
Variable or "hunting" arc.	<ol style="list-style-type: none"> 1. Wrong size, worn and/or melted contact tip. 2. Worn work cable or poor work connection. 3. Loose electrode or work cable connections. 	

 **CAUTION**

If for any reason you do not understand the test procedures or are unable to perform the tests/repairs safely, contact your **Local Lincoln Authorized Field Service Facility** for technical troubleshooting assistance before you proceed.

POWER FEED 10 / R



Observe all Safety Guidelines detailed throughout this manual

PROBLEMS (SYMPTOMS)	POSSIBLE CAUSE	RECOMMENDED COURSE OF ACTION
Variable or "hunting arc.	<ol style="list-style-type: none"> 1. Wrong size, worn and/or melted contact tip. 2. Worn work cable or poor work connection. 3. Loose electrode or work cable connections. 4. Wrong polarity. - Make sure electrode polarity is correct for process being used. 5. Gas nozzle extended beyond gun tip or wire stickout too long while welding. 6. Poor gas shielding on processes requiring gas. - Check gas flow and mixture. 	<p>If all recommended possible areas of misadjustment have been checked and the problem persists, Contact your local Lincoln Authorized Field Service Facility.</p>
Poor arc striking with sticking or "blast-offs", weld porosity, narrow and ropy looking bead, or electrode stubbing into plate while welding.	<ol style="list-style-type: none"> 1. Improper procedures or techniques. - See "Gas Metal Arc Welding Guide" (GS-100). 2. Improper gas shielding - Clean gas nozzle. Make certain that gas diffuser is not empty or turned off. Make certain gas flow rate is proper. 3. Remove gun liner and check rubber seal for any sign of deterioration or damage. Be sure set screw in connector block is in place and tightened against the liner bushing. 	

 **CAUTION**

If for any reason you do not understand the test procedures or are unable to perform the tests/repairs safely, contact your **Local Lincoln Authorized Field Service Facility** for technical troubleshooting assistance before you proceed.

POWER FEED 10 / R



Observe all Safety Guidelines detailed throughout this manual

PROBLEMS (SYMPTOMS)	POSSIBLE CAUSE	RECOMMENDED COURSE OF ACTION
Tip seizes in diffuser.	1. Tip overheating due to prolonged or excessive high current and/or duty cycle welding. <i>Note: A light application of high temperature antiseize lubricant (such as Lincoln E2067 Graphite Grease) may be applied to tip of threads.</i>	If all recommended possible areas of misadjustment have been checked and the problem persists, Contact your local Lincoln Authorized Field Service Facility.
Motor does not turn when trigger is pulled.	1. The wire drive motor may be overloaded. 2. Fault occurred	
The drive motor does not turn although arc voltage is present and the gas solenoid is on.	1. Fault occurred	
No control of wire feed speed motor. Gas solenoid operates properly and arc voltage is present. Wire feed speed can be set through ArcLink but WFS is erratic.	1. Damaged leads to the motor tachometer. 2. Damaged tachometer.	
Wire feed motor turns and gas solenoid operates, but no arc voltage is present.	1. Power source is unable to provide arc voltage because of thermal shutdown or other failure.	
Speed does not change when weld current flows.	1. Run-in and weld speeds are set to the same value. 2. Fault occurred	
Erratic arc length, especially with a pulse or STT program. Welding may or may not vary from normal procedure. Wire feeds properly.	1. The work sense lead (#21) or the electrode sense lead (#67) may have intermittent or poor connections. 2. Improper power source selection on the control P.C. board. 3. Welding Program Error.	
Wire feed speed is consistent and adjustable, but operates at the wrong speed.	1. DIP switch is incorrectly set for the wrong wire drive or gear ratio. 2. Fault occurred	

 **CAUTION**

If for any reason you do not understand the test procedures or are unable to perform the tests/repairs safely, contact your **Local Lincoln Authorized Field Service Facility** for technical troubleshooting assistance before you proceed.

POWER FEED 10 / R



WIRING DIAGRAM FOR POWER FEED 10 ROBOTICW

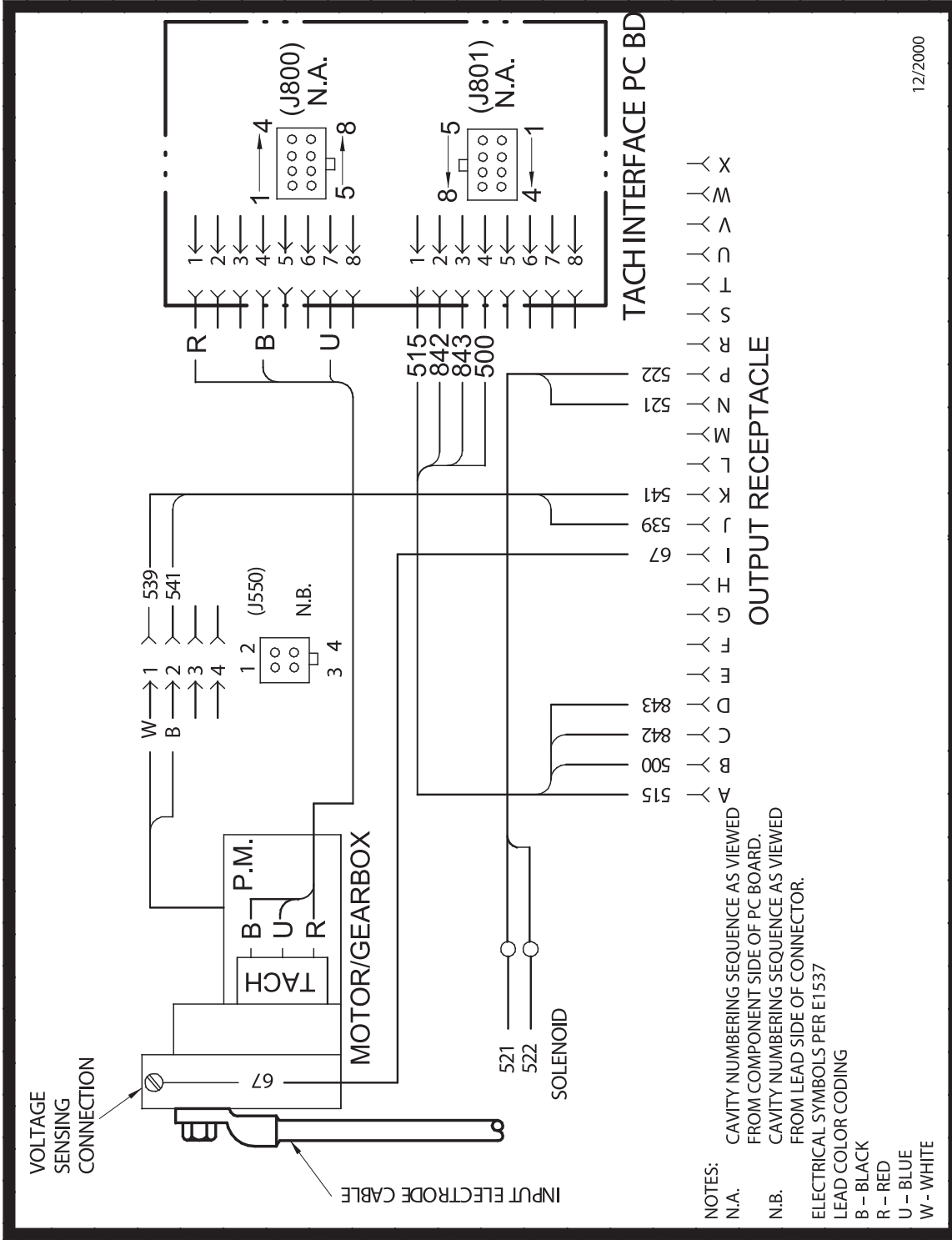

M19601

NOTE: This diagram is for reference only. It may not be accurate for all machines covered by this manual. The specific diagram for a particular code is pasted inside the machine on one of the enclosure panels. If the diagram is illegible, write to the Service Department for a replacement. Give the equipment code number..

POWER FEED 10 / R DIMENSION PRINT

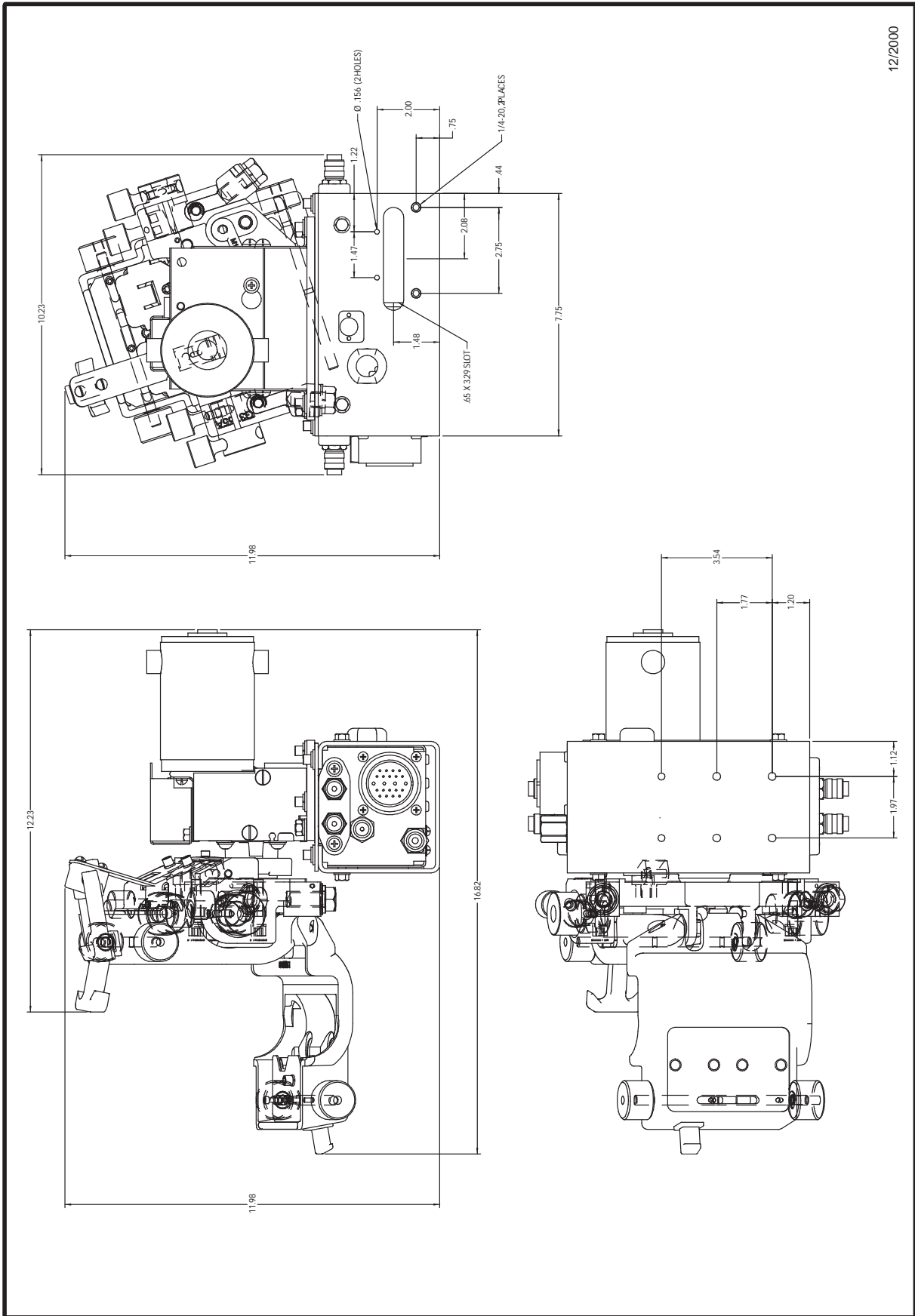

12/2000

L11579

POWER FEED 10 / R



NOTES

POWER FEED 10 / R



NOTES

POWER FEED 10 / R



WARNING	<ul style="list-style-type: none"> ● Do not touch electrically live parts or electrode with skin or wet clothing. ● Insulate yourself from work and ground. 	<ul style="list-style-type: none"> ● Keep flammable materials away. 	<ul style="list-style-type: none"> ● Wear eye, ear and body protection.
Spanish AVISO DE PRECAUCION	<ul style="list-style-type: none"> ● No toque las partes o los electrodos bajo carga con la piel o ropa mojada. ● Aíslese del trabajo y de la tierra. 	<ul style="list-style-type: none"> ● Mantenga el material combustible fuera del área de trabajo. 	<ul style="list-style-type: none"> ● Protéjase los ojos, los oídos y el cuerpo.
French ATTENTION	<ul style="list-style-type: none"> ● Ne laissez ni la peau ni des vêtements mouillés entrer en contact avec des pièces sous tension. ● Isolez-vous du travail et de la terre. 	<ul style="list-style-type: none"> ● Gardez à l'écart de tout matériel inflammable. 	<ul style="list-style-type: none"> ● Protégez vos yeux, vos oreilles et votre corps.
German WARNUNG	<ul style="list-style-type: none"> ● Berühren Sie keine stromführenden Teile oder Elektroden mit Ihrem Körper oder feuchter Kleidung! ● Isolieren Sie sich von den Elektroden und dem Erdboden! 	<ul style="list-style-type: none"> ● Entfernen Sie brennbares Material! 	<ul style="list-style-type: none"> ● Tragen Sie Augen-, Ohren- und Körperschutz!
Portuguese ATENÇÃO	<ul style="list-style-type: none"> ● Não toque partes elétricas e electrodos com a pele ou roupa molhada. ● Isole-se da peça e terra. 	<ul style="list-style-type: none"> ● Mantenha inflamáveis bem guardados. 	<ul style="list-style-type: none"> ● Use proteção para a vista, ouvido e corpo.
Japanese 注意事項	<ul style="list-style-type: none"> ● 通電中の電気部品、又は溶材にヒフやぬれた布で触れないこと。 ● 施工物やアースから身体が絶縁されている様にして下さい。 	<ul style="list-style-type: none"> ● 燃えやすいものの側での溶接作業は絶対にしてはなりません。 	<ul style="list-style-type: none"> ● 目、耳及び身体に保護具をして下さい。
Chinese 警告	<ul style="list-style-type: none"> ● 皮膚或濕衣物切勿接觸帶電部件及鎢條。 ● 使你自已與地面和工件絕緣。 	<ul style="list-style-type: none"> ● 把一切易燃物品移離工作場所。 	<ul style="list-style-type: none"> ● 佩戴眼、耳及身體勞動保護用具。
Korean 위험	<ul style="list-style-type: none"> ● 전도체나 용접봉을 젖은 형갑 또는 피부로 절대 접촉치 마십시오. ● 모재와 접지를 접촉치 마십시오. 	<ul style="list-style-type: none"> ● 인화성 물질을 접근시키지 마십시오. 	<ul style="list-style-type: none"> ● 눈, 귀와 몸에 보호장구를 착용하십시오.
Arabic تحذير	<ul style="list-style-type: none"> ● لا تلمس الاجزاء التي يسري فيها التيار الكهربائي أو الألكترود بجسد الجسم أو بالملابس المبللة بالماء. ● ضع عازلا على جسمك خلال العمل. 	<ul style="list-style-type: none"> ● ضع المواد القابلة للاشتعال في مكان بعيد. 	<ul style="list-style-type: none"> ● ضع أدوات وملابس واقية على عينيك وأذنيك وجسمك.

READ AND UNDERSTAND THE MANUFACTURER'S INSTRUCTION FOR THIS EQUIPMENT AND THE CONSUMABLES TO BE USED AND FOLLOW YOUR EMPLOYER'S SAFETY PRACTICES.

SE RECOMIENDA LEER Y ENTENDER LAS INSTRUCCIONES DEL FABRICANTE PARA EL USO DE ESTE EQUIPO Y LOS CONSUMIBLES QUE VA A UTILIZAR, SIGA LAS MEDIDAS DE SEGURIDAD DE SU SUPERVISOR.

LISEZ ET COMPRENEZ LES INSTRUCTIONS DU FABRICANT EN CE QUI REGARDE CET EQUIPMENT ET LES PRODUITS A ETRE EMPLOYES ET SUIVEZ LES PROCEDURES DE SECURITE DE VOTRE EMPLOYEUR.

LESEN SIE UND BEFOLGEN SIE DIE BETRIEBSANLEITUNG DER ANLAGE UND DEN ELEKTRODENEINSATZ DES HERSTELLERS. DIE UNFALLVERHÜTUNGSVORSCHRIFTEN DES ARBEITGEBERS SIND EBENFALLS ZU BEACHTEN.

			
<ul style="list-style-type: none"> ● Keep your head out of fumes. ● Use ventilation or exhaust to remove fumes from breathing zone. 	<ul style="list-style-type: none"> ● Turn power off before servicing. 	<ul style="list-style-type: none"> ● Do not operate with panel open or guards off. 	WARNING
<ul style="list-style-type: none"> ● Los humos fuera de la zona de respiración. ● Mantenga la cabeza fuera de los humos. Utilice ventilación o aspiración para gases. 	<ul style="list-style-type: none"> ● Desconectar el cable de alimentación de poder de la máquina antes de iniciar cualquier servicio. 	<ul style="list-style-type: none"> ● No operar con panel abierto o guardas quitadas. 	Spanish AVISO DE PRECAUCION
<ul style="list-style-type: none"> ● Gardez la tête à l'écart des fumées. ● Utilisez un ventilateur ou un aspirateur pour ôter les fumées des zones de travail. 	<ul style="list-style-type: none"> ● Débranchez le courant avant l'entretien. 	<ul style="list-style-type: none"> ● N'opérez pas avec les panneaux ouverts ou avec les dispositifs de protection enlevés. 	French ATTENTION
<ul style="list-style-type: none"> ● Vermeiden Sie das Einatmen von Schweißrauch! ● Sorgen Sie für gute Be- und Entlüftung des Arbeitsplatzes! 	<ul style="list-style-type: none"> ● Strom vor Wartungsarbeiten abschalten! (Netzstrom völlig öffnen; Maschine anhalten!) 	<ul style="list-style-type: none"> ● Anlage nie ohne Schutzgehäuse oder Innenschutzverkleidung in Betrieb setzen! 	German WARNUNG
<ul style="list-style-type: none"> ● Mantenha seu rosto da fumaça. ● Use ventilação e exaustão para remover fumo da zona respiratória. 	<ul style="list-style-type: none"> ● Não opere com as tampas removidas. ● Desligue a corrente antes de fazer serviço. ● Não toque as partes elétricas nuas. 	<ul style="list-style-type: none"> ● Mantenha-se afastado das partes moventes. ● Não opere com os painéis abertos ou guardas removidas. 	Portuguese ATENÇÃO
<ul style="list-style-type: none"> ● ヒュームから頭を離すようにして下さい。 ● 換気や排煙に十分留意して下さい。 	<ul style="list-style-type: none"> ● メンテナンス・サービスに取りかかる際には、まず電源スイッチを必ず切ってください。 	<ul style="list-style-type: none"> ● パネルやカバーを取り外したまま機械操作をしないで下さい。 	Japanese 注意事項
<ul style="list-style-type: none"> ● 頭部遠離煙霧。 ● 在呼吸區使用通風或排風器除煙。 	<ul style="list-style-type: none"> ● 維修前切斷電源。 	<ul style="list-style-type: none"> ● 儀表板打開或沒有安全罩時不準作業。 	Chinese 警告
<ul style="list-style-type: none"> ● 얼굴로부터 용접가스를 멀리하십시오. ● 호흡지역으로부터 용접가스를 제거하기 위해 가스제거기나 통풍기를 사용하십시오. 	<ul style="list-style-type: none"> ● 보수전에 전원을 차단하십시오. 	<ul style="list-style-type: none"> ● 판넬이 열린 상태로 작동치 마십시오. 	Korean 위험
<ul style="list-style-type: none"> ● ابعد رأسك بعيداً عن الدخان. ● استعمل التهوية أو جهاز ضغط الدخان للخارج لكي تبعد الدخان عن المنطقة التي تتنفس فيها. 	<ul style="list-style-type: none"> ● أقطع التيار الكهربائي قبل القيام بأية صيانة. 	<ul style="list-style-type: none"> ● لا تشغيل هذا الجهاز اذا كانت الاغطية الحديدية الواقية ليست عليه. 	Arabic تحذير

LEIA E COMPREENDA AS INSTRUÇÕES DO FABRICANTE PARA ESTE EQUIPAMENTO E AS PARTES DE USO, E SIGA AS PRÁTICAS DE SEGURANÇA DO EMPREGADOR.

使う機械や溶材のメーカーの指示書をよく読み、まず理解して下さい。そして貴社の安全規定に従って下さい。

請詳細閱讀並理解製造廠提供的說明以及應該使用的銀焊材料，並請遵守貴方的有閣勞動保護規定。

이 제품에 동봉된 작업지침서를 숙지하시고 귀사의 작업자 안전수칙을 준수하시기 바랍니다.

اقرأ بتمعن وافهم تعليمات المصنع المنتج لهذه المعدات والمواد قبل استعمالها واتبع تعليمات الوقاية لصاحب العمل.



• World's Leader in Welding and Cutting Products •

• Sales and Service through Subsidiaries and Distributors Worldwide •

Cleveland, Ohio 44117-1199 U.S.A. TEL: 216.481.8100 FAX: 216.486.1751 WEB SITE: www.lincolnelectric.com