

RED-D-ARC ***ES 275i***

IM803-B

August, 2006

For use with machines having Code Numbers: **10994,11166,11223 & 11266**

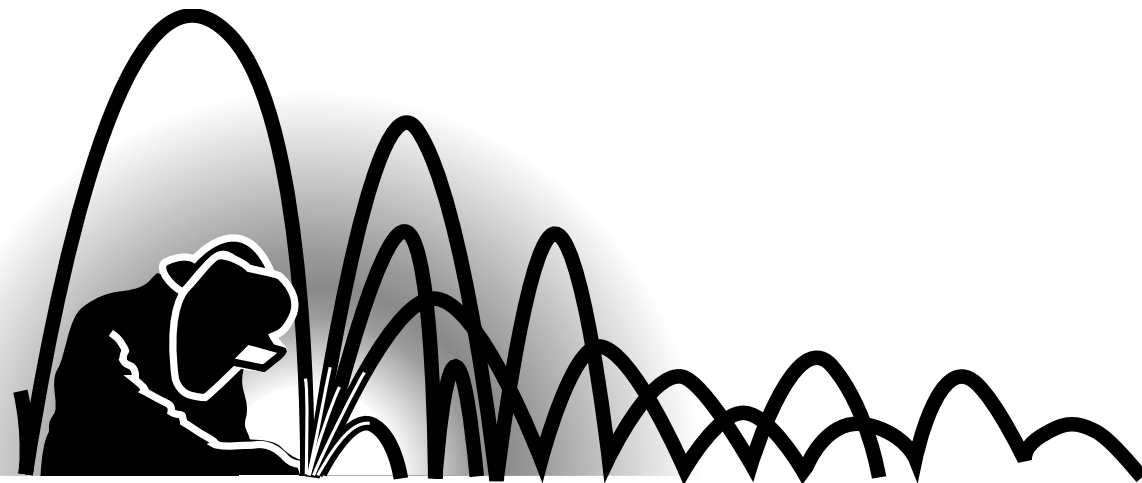

RED-D-ARC ***Welderrentals***

OPERATOR'S MANUAL

Red-D-Arc Spec-Built Welding Equipment

This **RED-D-ARC** welder is built to **RED-D-ARC Extreme Duty** design specifications by Lincoln Electric.

Safety Depends on You

This welder is designed and built with safety in mind.

However, your overall safety can be increased by proper installation ... and thoughtful operation on your part.

DO NOT INSTALL, OPERATE OR REPAIR THIS EQUIPMENT WITHOUT READING THIS MANUAL AND THE SAFETY PRECAUTIONS CONTAINED THROUGHOUT.

And, most importantly, think before you act and be careful.

1-800-245-3660

North America's Largest Fleet of Welding Equipment

! WARNING

! CALIFORNIA PROPOSITION 65 WARNINGS !

Diesel engine exhaust and some of its constituents are known to the State of California to cause cancer, birth defects, and other reproductive harm.

The Above For Diesel Engines

The engine exhaust from this product contains chemicals known to the State of California to cause cancer, birth defects, or other reproductive harm.

The Above For Gasoline Engines

ARC WELDING CAN BE HAZARDOUS. PROTECT YOURSELF AND OTHERS FROM POSSIBLE SERIOUS INJURY OR DEATH. KEEP CHILDREN AWAY. PACEMAKER WEARERS SHOULD CONSULT WITH THEIR DOCTOR BEFORE OPERATING.

Read and understand the following safety highlights. For additional safety information, it is strongly recommended that you purchase a copy of "Safety in Welding & Cutting - ANSI Standard Z49.1" from the American Welding Society, P.O. Box 351040, Miami, Florida 33135 or CSA Standard W117.2-1974. A Free copy of "Arc Welding Safety" booklet E205 is available from the Lincoln Electric Company, 22801 St. Clair Avenue, Cleveland, Ohio 44117-1199.

BE SURE THAT ALL INSTALLATION, OPERATION, MAINTENANCE AND REPAIR PROCEDURES ARE PERFORMED ONLY BY QUALIFIED INDIVIDUALS.



FOR ENGINE powered equipment.

1.a. Turn the engine off before troubleshooting and maintenance work unless the maintenance work requires it to be running.



1.b. Operate engines in open, well-ventilated areas or vent the engine exhaust fumes outdoors.



1.c. Do not add the fuel near an open flame welding arc or when the engine is running. Stop the engine and allow it to cool before refueling to prevent spilled fuel from vaporizing on contact with hot engine parts and igniting. Do not spill fuel when filling tank. If fuel is spilled, wipe it up and do not start engine until fumes have been eliminated.

1.d. Keep all equipment safety guards, covers and devices in position and in good repair. Keep hands, hair, clothing and tools away from V-belts, gears, fans and all other moving parts when starting, operating or repairing equipment.

1.e. In some cases it may be necessary to remove safety guards to perform required maintenance. Remove guards only when necessary and replace them when the maintenance requiring their removal is complete. Always use the greatest care when working near moving parts.



1.f. Do not put your hands near the engine fan. Do not attempt to override the governor or idler by pushing on the throttle control rods while the engine is running.

1.g. To prevent accidentally starting gasoline engines while turning the engine or welding generator during maintenance work, disconnect the spark plug wires, distributor cap or magneto wire as appropriate.



1.h. To avoid scalding, do not remove the radiator pressure cap when the engine is hot.



ELECTRIC AND MAGNETIC FIELDS may be dangerous

2.a. Electric current flowing through any conductor causes localized Electric and Magnetic Fields (EMF). Welding current creates EMF fields around welding cables and welding machines

2.b. EMF fields may interfere with some pacemakers, and welders having a pacemaker should consult their physician before welding.

2.c. Exposure to EMF fields in welding may have other health effects which are now not known.

2.d. All welders should use the following procedures in order to minimize exposure to EMF fields from the welding circuit:

2.d.1. Route the electrode and work cables together - Secure them with tape when possible.

2.d.2. Never coil the electrode lead around your body.

2.d.3. Do not place your body between the electrode and work cables. If the electrode cable is on your right side, the work cable should also be on your right side.

2.d.4. Connect the work cable to the workpiece as close as possible to the area being welded.

2.d.5. Do not work next to welding power source.

Mar '95



ELECTRIC SHOCK can kill.

- 3.a. The electrode and work (or ground) circuits are electrically "hot" when the welder is on. Do not touch these "hot" parts with your bare skin or wet clothing. Wear dry, hole-free gloves to insulate hands.
- 3.b. Insulate yourself from work and ground using dry insulation. Make certain the insulation is large enough to cover your full area of physical contact with work and ground.
- In addition to the normal safety precautions, if welding must be performed under electrically hazardous conditions (in damp locations or while wearing wet clothing; on metal structures such as floors, gratings or scaffolds; when in cramped positions such as sitting, kneeling or lying, if there is a high risk of unavoidable or accidental contact with the workpiece or ground) use the following equipment:**
- Semiautomatic DC Constant Voltage (Wire) Welder.
 - DC Manual (Stick) Welder.
 - AC Welder with Reduced Voltage Control.
- 3.c. In semiautomatic or automatic wire welding, the electrode, electrode reel, welding head, nozzle or semiautomatic welding gun are also electrically "hot".
- 3.d. Always be sure the work cable makes a good electrical connection with the metal being welded. The connection should be as close as possible to the area being welded.
- 3.e. Ground the work or metal to be welded to a good electrical (earth) ground.
- 3.f. Maintain the electrode holder, work clamp, welding cable and welding machine in good, safe operating condition. Replace damaged insulation.
- 3.g. Never dip the electrode in water for cooling.
- 3.h. Never simultaneously touch electrically "hot" parts of electrode holders connected to two welders because voltage between the two can be the total of the open circuit voltage of both welders.
- 3.i. When working above floor level, use a safety belt to protect yourself from a fall should you get a shock.
- 3.j. Also see Items 6.c. and 8.



ARC RAYS can burn.

- 4.a. Use a shield with the proper filter and cover plates to protect your eyes from sparks and the rays of the arc when welding or observing open arc welding. Headshield and filter lens should conform to ANSI Z87.1 standards.
- 4.b. Use suitable clothing made from durable flame-resistant material to protect your skin and that of your helpers from the arc rays.
- 4.c. Protect other nearby personnel with suitable, non-flammable screening and/or warn them not to watch the arc nor expose themselves to the arc rays or to hot spatter or metal.



FUMES AND GASES can be dangerous.

- 5.a. Welding may produce fumes and gases hazardous to health. Avoid breathing these fumes and gases. When welding, keep your head out of the fume. Use enough ventilation and/or exhaust at the arc to keep fumes and gases away from the breathing zone. **When welding with electrodes which require special ventilation such as stainless or hard facing (see instructions on container or MSDS) or on lead or cadmium plated steel and other metals or coatings which produce highly toxic fumes, keep exposure as low as possible and below Threshold Limit Values (TLV) using local exhaust or mechanical ventilation. In confined spaces or in some circumstances, outdoors, a respirator may be required. Additional precautions are also required when welding on galvanized steel.**
5. b. The operation of welding fume control equipment is affected by various factors including proper use and positioning of the equipment, maintenance of the equipment and the specific welding procedure and application involved. Worker exposure level should be checked upon installation and periodically thereafter to be certain it is within applicable OSHA PEL and ACGIH TLV limits.
- 5.c. Do not weld in locations near chlorinated hydrocarbon vapors coming from degreasing, cleaning or spraying operations. The heat and rays of the arc can react with solvent vapors to form phosgene, a highly toxic gas, and other irritating products.
- 5.d. Shielding gases used for arc welding can displace air and cause injury or death. Always use enough ventilation, especially in confined areas, to insure breathing air is safe.
- 5.e. Read and understand the manufacturer's instructions for this equipment and the consumables to be used, including the material safety data sheet (MSDS) and follow your employer's safety practices. MSDS forms are available from your welding distributor or from the manufacturer.
- 5.f. Also see item 1.b.

AUG 06

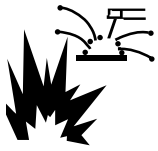

WELDING SPARKS can cause fire or explosion.

6.a. Remove fire hazards from the welding area. If this is not possible, cover them to prevent the welding sparks from starting a fire.

Remember that welding sparks and hot materials from welding can easily go through small cracks and openings to adjacent areas. Avoid welding near hydraulic lines. Have a fire extinguisher readily available.

- 6.b. Where compressed gases are to be used at the job site, special precautions should be used to prevent hazardous situations. Refer to "Safety in Welding and Cutting" (ANSI Standard Z49.1) and the operating information for the equipment being used.
- 6.c. When not welding, make certain no part of the electrode circuit is touching the work or ground. Accidental contact can cause overheating and create a fire hazard.
- 6.d. Do not heat, cut or weld tanks, drums or containers until the proper steps have been taken to insure that such procedures will not cause flammable or toxic vapors from substances inside. They can cause an explosion even though they have been "cleaned". For information, purchase "Recommended Safe Practices for the Preparation for Welding and Cutting of Containers and Piping That Have Held Hazardous Substances", AWS F4.1 from the American Welding Society (see address above).
- 6.e. Vent hollow castings or containers before heating, cutting or welding. They may explode.
- 6.f. Sparks and spatter are thrown from the welding arc. Wear oil free protective garments such as leather gloves, heavy shirt, cuffless trousers, high shoes and a cap over your hair. Wear ear plugs when welding out of position or in confined places. Always wear safety glasses with side shields when in a welding area.
- 6.g. Connect the work cable to the work as close to the welding area as practical. Work cables connected to the building framework or other locations away from the welding area increase the possibility of the welding current passing through lifting chains, crane cables or other alternate circuits. This can create fire hazards or overheat lifting chains or cables until they fail.
- 6.h. Also see item 1.c.

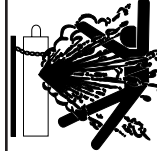

CYLINDER may explode if damaged.

7.a. Use only compressed gas cylinders containing the correct shielding gas for the process used and properly operating regulators designed for the gas and pressure used. All hoses, fittings, etc. should be suitable for the application and maintained in good condition.

- 7.b. Always keep cylinders in an upright position securely chained to an undercarriage or fixed support.
- 7.c. Cylinders should be located:
 - Away from areas where they may be struck or subjected to physical damage.
 - A safe distance from arc welding or cutting operations and any other source of heat, sparks, or flame.
- 7.d. Never allow the electrode, electrode holder or any other electrically "hot" parts to touch a cylinder.
- 7.e. Keep your head and face away from the cylinder valve outlet when opening the cylinder valve.
- 7.f. Valve protection caps should always be in place and hand tight except when the cylinder is in use or connected for use.
- 7.g. Read and follow the instructions on compressed gas cylinders, associated equipment, and CGA publication P-1, "Precautions for Safe Handling of Compressed Gases in Cylinders," available from the Compressed Gas Association 1235 Jefferson Davis Highway, Arlington, VA 22202.



FOR ELECTRICALLY powered equipment.

- 8.a. Turn off input power using the disconnect switch at the fuse box before working on the equipment.
- 8.b. Install equipment in accordance with the U.S. National Electrical Code, all local codes and the manufacturer's recommendations.
- 8.c. Ground the equipment in accordance with the U.S. National Electrical Code and the manufacturer's recommendations.

Mar '95

PRÉCAUTIONS DE SÛRETÉ

Pour votre propre protection lire et observer toutes les instructions et les précautions de sûreté spécifiques qui paraissent dans ce manuel aussi bien que les précautions de sûreté générales suivantes:

Sûreté Pour Soudage A L'Arc

1. Protégez-vous contre la secousse électrique:
 - a. Les circuits à l'électrode et à la pièce sont sous tension quand la machine à souder est en marche. Eviter toujours tout contact entre les parties sous tension et la peau nue ou les vêtements mouillés. Porter des gants secs et sans trous pour isoler les mains.
 - b. Faire très attention de bien s'isoler de la masse quand on soude dans des endroits humides, ou sur un plancher métallique ou des grilles métalliques, principalement dans les positions assis ou couché pour lesquelles une grande partie du corps peut être en contact avec la masse.
 - c. Maintenir le porte-électrode, la pince de masse, le câble de soudage et la machine à souder en bon et sûr état de fonctionnement.
 - d. Ne jamais plonger le porte-électrode dans l'eau pour le refroidir.
 - e. Ne jamais toucher simultanément les parties sous tension des porte-électrodes connectés à deux machines à souder parce que la tension entre les deux pinces peut être le total de la tension à vide des deux machines.
 - f. Si on utilise la machine à souder comme une source de courant pour soudage semi-automatique, ces précautions pour le porte-électrode s'appliquent aussi au pistolet de soudage.
2. Dans le cas de travail au dessus du niveau du sol, se protéger contre les chutes dans le cas où on reçoit un choc. Ne jamais enrouler le câble-électrode autour de n'importe quelle partie du corps.
3. Un coup d'arc peut être plus sévère qu'un coup de soleil, donc:
 - a. Utiliser un bon masque avec un verre filtrant approprié ainsi qu'un verre blanc afin de se protéger les yeux du rayonnement de l'arc et des projections quand on soude ou quand on regarde l'arc.
 - b. Porter des vêtements convenables afin de protéger la peau de soudeur et des aides contre le rayonnement de l'arc.
 - c. Protéger l'autre personnel travaillant à proximité au soudage à l'aide d'écrans appropriés et non-inflammables.
4. Des gouttes de laitier en fusion sont émises de l'arc de soudage. Se protéger avec des vêtements de protection libres de l'huile, tels que les gants en cuir, chemise épaisse, pantalons sans revers, et chaussures montantes.

5. Toujours porter des lunettes de sécurité dans la zone de soudage. Utiliser des lunettes avec écrans latéraux dans les zones où l'on pique le laitier.
6. Eloigner les matériaux inflammables ou les recouvrir afin de prévenir tout risque d'incendie dû aux étincelles.
7. Quand on ne soude pas, poser la pince à un endroit isolé de la masse. Un court-circuit accidentel peut provoquer un échauffement et un risque d'incendie.
8. S'assurer que la masse est connectée le plus près possible de la zone de travail qu'il est pratique de le faire. Si on place la masse sur la charpente de la construction ou d'autres endroits éloignés de la zone de travail, on augmente le risque de voir passer le courant de soudage par les chaînes de levage, câbles de grue, ou autres circuits. Cela peut provoquer des risques d'incendie ou d'échauffement des chaînes et des câbles jusqu'à ce qu'ils se rompent.
9. Assurer une ventilation suffisante dans la zone de soudage. Ceci est particulièrement important pour le soudage de tôles galvanisées plombées, ou cadmiées ou tout autre métal qui produit des fumées toxiques.
10. Ne pas souder en présence de vapeurs de chlore provenant d'opérations de dégraissage, nettoyage ou pistolage. La chaleur ou les rayons de l'arc peuvent réagir avec les vapeurs du solvant pour produire du phosgène (gas fortement toxique) ou autres produits irritants.
11. Pour obtenir de plus amples renseignements sur la sûreté, voir le code "Code for safety in welding and cutting" CSA Standard W 117.2-1974.

PRÉCAUTIONS DE SÛRETÉ POUR LES MACHINES À SOUDER À TRANSFORMATEUR ET À REDRESSEUR

1. Relier à la terre le chassis du poste conformément au code de l'électricité et aux recommandations du fabricant. Le dispositif de montage ou la pièce à souder doit être branché à une bonne mise à la terre.
2. Autant que possible, l'installation et l'entretien du poste seront effectués par un électricien qualifié.
3. Avant de faire des travaux à l'intérieur de poste, la débrancher à l'interrupteur à la boîte de fusibles.
4. Garder tous les couvercles et dispositifs de sûreté à leur place.

Mar. '93



Thank You

for selecting a **QUALITY** product by Lincoln Electric. We want you to take pride in operating this Lincoln Electric Company product ●● as much pride as we have in bringing this product to you!

Please Examine Carton and Equipment For Damage Immediately

When this equipment is shipped, title passes to the purchaser upon receipt by the carrier. Consequently, Claims for material damaged in shipment must be made by the purchaser against the transportation company at the time the shipment is received.

Please record your equipment identification information below for future reference. This information can be found on your machine nameplate.

Product _____

Model Number _____

Code Number or Date Code _____

Serial Number _____

Date Purchased _____

Where Purchased _____

Whenever you request replacement parts or information on this equipment, always supply the information you have recorded above. The code number is especially important when identifying the correct replacement parts.

On-Line Product Registration

- Register your machine with Lincoln Electric either via fax or over the Internet.

- For faxing: Complete the form on the back of the warranty statement included in the literature packet accompanying this machine and fax the form per the instructions printed on it.
- For On-Line Registration: Go to our **WEB SITE at www.lincolnelectric.com**. Choose "Quick Links" and then "Product Registration". Please complete the form and submit your registration.

Read this Operators Manual completely before attempting to use this equipment. Save this manual and keep it handy for quick reference. Pay particular attention to the safety instructions we have provided for your protection. The level of seriousness to be applied to each is explained below:

⚠ WARNING

This statement appears where the information **must** be followed **exactly** to avoid **serious personal injury** or **loss of life**.

⚠ CAUTION

This statement appears where the information **must** be followed to avoid **minor personal injury** or **damage to this equipment**.

Installation.....	Section A
Technical Specifications	A-1
Safety Precautions	A-2
Suitable Location	A-2
Stacking	A-2
Tilting.....	A-2
High Frequency Protection.....	A-2
Input Connections	A-2
Input Fuse and Supply Wire.....	A-2
Input Supply Connections	A-2
Power Input Connections	A-2
Input Voltage Reconnect Procedure	A-3
Output Connections.....	A-3
Output Cables	A-3
<hr/>	
Operation.....	Section B
Safety Precautions	B-1
General Description.....	B-1
Operational Features	B-1
Welding Capability	B-1
Limitations	B-1
Controls and Settings	B-2,B-3
Constant Current Processes	B-3
Parallel Operation.....	B-3
Overload Protection.....	B-4
Thermal Protection	B-4
Fan	B-4
Power-Up Sequence	B-4
<hr/>	
Maintenance.....	Section D
Input Filter Capacitor Discharge Procedure	D-1
Routine Maintenance.....	D-2
Filter Capacitor Conditioning	D-2
Location of Maintenance Components	D-3
<hr/>	
Troubleshooting	Section E
Safety Precautions.....	E-1
PC Board Troubleshooting Procedures	E-2
Troubleshooting Guide.....	E-3 thru E-7
<hr/>	
Wiring Diagrams and Dimension Print	Section F
<hr/>	
Parts Pages	P-477 Series
<hr/>	

Technical Specifications - ES 275i

INPUT AT RATED OUTPUT - THREE PHASE ONLY

INPUT VOLTS-Hz	OUTPUT CONDITIONS	INPUT CURRENT AMPS	Idle Power	Efficiency @ Rated Output
208/230/460/575V - 60Hz.	200A@28V.100% 250A@30V. 60% 275A@31V. 35%	27/25/13/11 34/33/17/14 38/37/19/16	150W Max	87%
220/380/400/415/440 - 50Hz	200A@28V.100% 250A@30V. 35%	25/15/15/14/13 32/20/19/18/17		

INPUT AT RATED OUTPUT - SINGLE PHASE ONLY

INPUT VOLTS-Hz	OUTPUT CONDITIONS	INPUT CURRENT AMPS	Idle Power	Efficiency @ Rated Output
208/230/460/575V - 60Hz.	200A@28V.100% 250A@30V. 60% 275A@31V.* 35%	55/48/26/21 72/62/33/27 80/70/38/31	150W Max	87%
220/380/400/415/440 - 50Hz	200A@28V.100% 250A@30V. 35%	48/32/30/29/27 63/42/40/38/36		

OUTPUT (THREE AND SINGLE PHASE)

WELDING CURRENT RANGE	NO LOAD VOLTAGE
5-275 Amps	70 VDC

RECOMMENDED MINIMUM INPUT WIRE AND FUSE SIZES

THREE PHASE			SINGLE PHASE		
Input Voltage-Hz	Cord Size AWG(mm ²) based on a type S, SJ, SJO or SJT Flexible cord in 30°C Ambient	Fuse Size (Time Delay Fuse) Amps	Input Voltage-Hz	Cord Size AWG(mm ²) based on a type S, SJ, SJO or SJT Flexible cord in 30°C Ambient	Fuse Size (Time Delay Fuse) Amps
208/230-60	8(8.4)	60	208-60	4 (25) ¹	100
460/575-60	14(2.5)	35	230-60	6(16) ¹	100
			460/575-60	10 (6)	60
220-50	8(8.4)	60	220-50	6(16) ¹	100
380/400/415-50	12(4)	35	380/400/415-50	8(10)	60
440-50	14(2.5)	35	440-50	10(6)	60

PHYSICAL DIMENSIONS

Height	Width	Depth	Weight (With Cord)
13.6in.(345mm) - Handle Folded Down	9.0 in.(229mm)	20.25 in.(514mm)	54.5lbs. (24.7Kg)
16in.(406mm) - Handle Up		21.7 in.(551)-With Cord Strain Relief	

TEMPERATURE RANGES

OPERATING TEMPERATURE RANGE	STORAGE TEMPERATURE RANGE
-20°C to +40°C	-40°C to +40°C

(1) When operating on these inputs, the line cord may need to be changed

* On 208VAC single phase the 35% duty cycle output rating is 275A @ 29V.

Read this entire installation section before you start installation.

SAFETY PRECAUTIONS

⚠ WARNING

ELECTRIC SHOCK can kill.



- Have an electrician install and service this equipment.
- Turn the input power off at the fuse box before working on equipment.

- Do not touch electrically hot parts.
- Be sure to discharge capacitors with the procedure outlined in the Maintenance Section of this manual before working in that area of the equipment.

SELECT SUITABLE LOCATION

The ES 275i will operate in harsh environments. Even so, it is important that simple preventative measures are followed in order to assure long life and reliable operation.

- The machine must be located where there is free circulation of clean air such that air movement in the back and out the front will not be restricted.
- Dirt and dust that can be drawn into the machine should be kept to a minimum. Failure to observe these precautions can result in excessive operating temperatures and nuisance shutdown.
- Keep machine dry. Shelter from rain and snow. Do not place on wet ground or in puddles.

⚠ CAUTION

- **DO NOT MOUNT OVER COMBUSTIBLE SURFACES.**

Where there is a combustible surface directly under stationary or fixed electrical equipment, that surface shall be covered with a steel plate at least .06”(1.6mm) thick, which shall extend not less than 5.90”(150mm) beyond the equipment on all sides.

STACKING

ES 275i's cannot be stacked.

TILTING

Place the machine directly on a secure, level surface. The machine may topple over if this procedure is not followed.

HIGH FREQUENCY PROTECTION

Locate the ES 275i away from radio controlled machinery.

⚠ CAUTION

The normal operation of the ES 275i may adversely affect the operation of RF controlled equipment, which may result in bodily injury or damage to the equipment.

INPUT CONNECTIONS

The ES 275i should be connected only by a qualified electrician. Installation should be made in accordance with all local and national electric codes and the information detailed below.

INPUT FUSE AND SUPPLY WIRE

Refer to the **Technical Specifications** page at the beginning of this chapter for the proper fuse sizes and supply cable sizes.

- Fuse the input circuit with recommended super lag fuses or delay type circuit breakers.
- Install the proper fuse in the fuse holder in the main disconnect panel.

INPUT SUPPLY CONNECTIONS

Be sure the voltage phase and frequency of the input power is as specified on the rating plate, located on the rear of the machine.

Supply line entry provision is in the case rear panel.

POWER INPUT CONNECTION

A 10 ft. power cord is provided and wired into the machine. Follow the power cord connection instructions. Incorrect connection may result in equipment damage.

Single Phase Input: Connect green lead to ground per National Electrical Code. Connect black and white or brown leads to power. Wrap red lead with tape to provide 600V insulation.

Three Phase Input: Connect green lead to ground per National Electrical Code. Connect black, red and white or brown leads to power.

ES 275i



INPUT VOLTAGE RECONNECT PROCEDURE

When received directly from the factory, units are connected for, 460 VAC. If 460 VAC is the desired input, then the machine may be connected to the power system without any setup required inside the reconnect door. For other voltages refer to the instructions located on the Reconnect Panel Access Door or follow the instructions below.

CAUTION

Failure to follow these instructions can cause immediate failure of components within the welder.

OUTPUT CONNECTIONS

Refer to figure B.1 for the location of the 3-Pin Remote Receptacle and the Output Terminals.

OUTPUT CABLES

Select the output cable size based on Table A.1.

TABLE A.1

Cable Sizes for Combined Length of Electrode and Work Cable (Copper Cable Rated at 75°C).

Length	Cable Size
up to 150 ft.(46m)	1/0 (50mm ²)
up to 250 ft.(72m)	2/0 (70mm ²)

1. Open the access door on the left side of the machine.
2. For 208-230: Position the large switch to 208-230.
For 380-575: Position the large switch to 380-575.
3. Move the "A" lead to the appropriate terminal.
Refer to figure A.1 below.

RECONNECT PROCEDURE

1. BE SURE POWER SWITCH IS OFF.
2. CONNECT LEAD 'A' TO DESIRED INPUT VOLTAGE RANGE.

575V	
440-460V	
380-415V	
220-230V	
208V	

A

3. POSITION SWITCH TO DESIRED INPUT VOLTAGE RANGE.

↑

VOLTAGE=380-575V

↓

VOLTAGE=208-230V

WARNING

- Disconnect input power before inspecting or servicing machine.
- Do not operate with wraparound removed.
- Do not touch electrically live parts.
- Only qualified persons should install, use or service this equipment.

IF MACHINE CEASES TO OPERATE (NO METER, NO FAN) AND THERE IS NO OTHER KNOWN FAILURE: CHECK FUSE; REPLACE WITH SPECIFIED FUSE.

ELECTRIC SHOCK CAN KILL

Figure A.1 Input Voltage Reconnect Instructions

Read and understand this entire section before operating your machine.

SAFETY PRECAUTIONS

WARNING



ELECTRIC SHOCK can kill.

- Do not touch electrically live parts such as output terminals or internal wiring.
- Insulate yourself from the work and ground.
- Always wear dry insulating gloves.



FUMES AND GASES can be dangerous.

- Keep your head out of fumes.
- Use ventilation or exhaust to remove fumes from breathing zone.

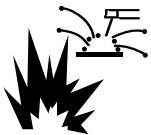

WELDING, CUTTING and GOUGING SPARKS can cause fire or explosion

- Keep flammable material away.
- Do not weld, cut or gouge on containers that have held combustibles.



ARC RAYS can burn.

- Wear eye, ear and body protection.

Only qualified personnel should operate this equipment. Observe all safety information throughout this manual.

GENERAL DESCRIPTION

The ES 275i is a 275 amp arc welding power source that utilizes single or three phase input power, to produce constant current output. The welding response of this Invertec has been optimized for stick (SMAW) and TIG (GTAW).

OPERATIONAL FEATURES

The ES 275i provides continuous total range output current adjustment, selectable welding modes and local or remote output control. Welding characteristics can be controlled via an arc force control. Additionally, starting characteristics can be adjusted via a "hot start" control.

WELDING CAPABILITY

The ES 275i is rated at 275 amps, 35% duty cycle (based on a 10 minute cycle). It is also rated at 200 amps, 100% duty cycle, and 250 amps, 60% duty cycle.

LIMITATIONS

The ES 275i is not recommended for pipe thawing.

CONTROLS AND SETTINGS

All operator controls and adjustments are located on the case front of the ES 275i. Refer to Figure B.1 and corresponding explanations.

FIGURE B.1 — CASE FRONT CONTROLS.

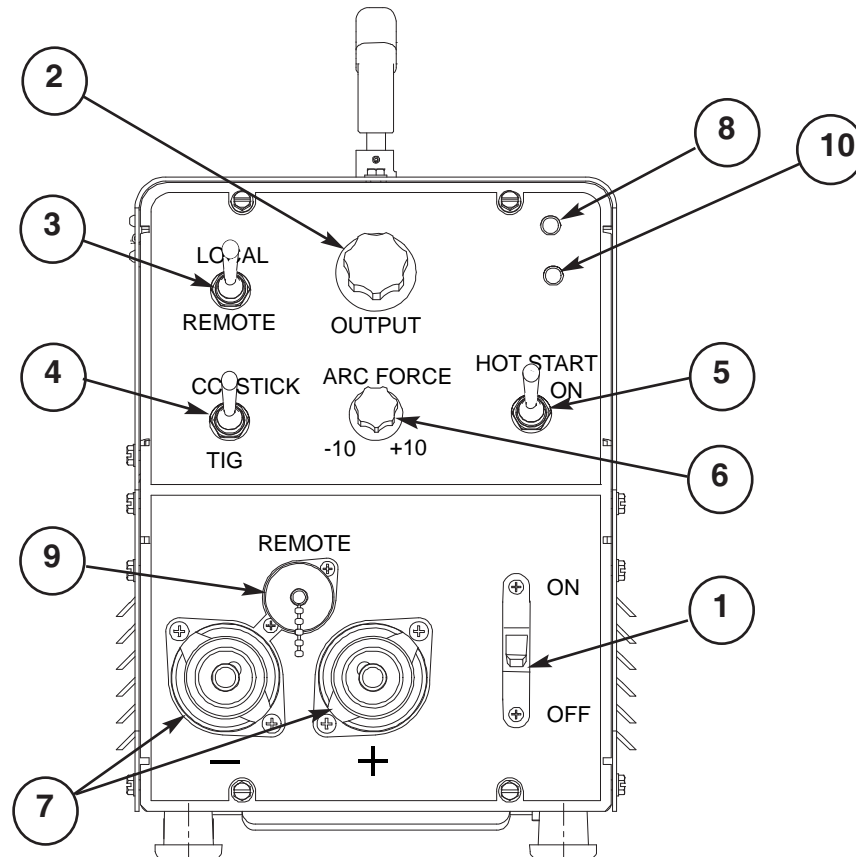

1. POWER SWITCH - Place the lever in the “ON” position to energize the machine. When the power is on the output will be energized in STICK (SMAW) mode and TIG (GTAW) if the remote is set to local control. At power up the thermal Light and Fan will turn on for approximately 3 seconds.

2. OUTPUT CONTROL - This controls the output current. Control is provided over the entire output range of the power source with (1) turn of the control knob. This control may be adjusted while under load to change power source output. When using remote control this function becomes the limit setting.

3. LOCAL/REMOTE SWITCH - Place in the “LOCAL” position to allow output adjustment at the machine. Place in the “REMOTE” position to allow output adjustment at remote pot or amptrol. In Remote, the machine output control pot is the limit setting for remote control.

4. MODE SWITCH

CC -Stick (SMAW) Use this mode for all stick welding. Output energized when machine is on.

TIG (GTAW) Optimized for touch start use. Short circuit current is limited to approximately 20 amps to aid in touch starting.

5. HOT START - Controls the amount of starting energy in CC Stick (SMAW). The Hot Start can be either turned on or off. When on, it provides a striking current at 260% of the set current or 275A whichever is larger then quickly reverts to the set current in 0.4 second.

6. ARC FORCE - This control functions in CC Stick (SMAW) modes to adjust the Arc Force. The arc is soft at the minimum settings and more forceful or driving at the maximum settings. Higher spatter levels may be present at the maximum settings. **Full range is from -10(Soft) to +10(Crisp)**

7. OUTPUT TERMINALS - These quick disconnect terminals are compatible with **TWECO®*** connectors. The terminal provide connection points for the electrode and work cables. Refer to **Output Connection** in the Installation chapter for proper cable sizes. For positive polarity welding connect the electrode cable to the positive terminal and the work cable to the negative terminal. To weld negative polarity reverse the electrode and work cables.

* TWECO® is registered trademark of Thermo Dyne Corporation.

8. THERMAL SHUTDOWN INDICATOR - This light will illuminate if an internal thermostat has been activated. Machine output will return after the internal components have returned to a normal operating temperature. See **Thermal Protection** later in this Operation chapter.

9. 3-PIN REMOTE RECEPTACLE

3-Pin remote control allows for remote control of the Output current.

10. POWER LIGHT - This Light will illuminate when the power switch is in the "ON" Position.

CONSTANT CURRENT PROCESSES

STICK WELDING*

The Invertec may be utilized as a manual DC arc welder with the electrode cable, work cable, and electrode holder being the only equipment required.

AIR CARBON ARC CUTTING*

Air carbon arc cutting may be performed with the Invertec within its output rating using 3/16"(4.8mm) diameter carbon rods. Output cables, an air carbon arc electrode cable assembly, and a source of compressed air are required.

TIG WELDING*

The ES 275i is capable of touch start TIG welding. An electrode cable, work cable, TIG torch, and gas supply with regulator are required.

Touch starting is done as follows:

1. Place the shield cup edge on the work piece.
2. Rock the tungsten down to touch.
3. Gently rock back the tungsten from the work-piece.

Note: The short circuit current is limited to 20 amps to aid in touch starting. Panel output control becomes the current limit setting when in remote control.

***Note:** Operating this machine with the output control set to maximum may cause the machine to phase back and the arc to go out. This occurs because the welding current exceeded 300 amps and the machine's protection circuitry activated. Turn the output control down to correct this condition.

PARALLEL OPERATION

The Invertec's are operable in parallel. For best results, the currents of each machine should be reasonably well shared. As an example, with two machines set up in parallel for a 300 amp procedure, each machine should be set to deliver approximately 150 amps, not 200 amps from one and 100 amps from the other. This will minimize nuisance feedback conditions. In general, more than two machines in parallel will not be effective due to the voltage requirements of procedures in that power range.

To set machine outputs, start with output control pots and arc force pots in identical positions. Adjust outputs and arc forces to maintain current sharing while establishing the proper output current.

OVERLOAD PROTECTION

The machine is electrically protected from producing high output currents. Should the output current exceed 300A, an electronic protection circuit will reduce the current to less than 200A. The machine will continue to produce this low current until the protection circuit is reset. Reset occurs when the output load is removed.

Note: When TIG welding with the Output Knob at or above 275 Amps the Arc may go out.

THERMAL PROTECTION

Thermostats protect the machine from excessive operating temperatures. Excessive temperatures may be caused by a lack of cooling air or operating the machine beyond the duty cycle and output rating. If excessive operating temperature should occur, the thermostats will prevent output voltage or current.

Thermostats are self-resetting once the machine cools sufficiently.

FAN

The cooling fan on the ES 275i operates once 15 amps of welding current is drawn and for 7 minutes after the output current has stopped flowing.

The fan will also run anytime the machine has over heated.

POWER-UP SEQUENCE

At power up the thermal light (and Power light on codes 11164 and above) turns on and the fans run for approximately 3 seconds. This is the pre-charge time for the main capacitors. After this time the fans and thermal light turn off and the pre-charge relay closes to apply full line power to the capacitors. At this time the machine is ready to weld.

⚠ WARNING

ELECTRIC SHOCK can kill.

- Have an electrician install and service this equipment.
- Turn the input power off at the fuse box before working on equipment.
- Do not touch electrically hot parts.
- Prior to Performing preventative maintenance, perform the following capacitor discharge procedure to avoid electric shock.

INPUT FILTER CAPACITOR DISCHARGE PROCEDURE

1. Turn off input power or disconnect input power lines.
2. Remove the 5/16" hex head screws from the side and top of the machine and remove wrap-around machine cover.
3. Be careful not to make contact with the capacitor terminals that are located in the top and bottom of the Power Board.
4. Obtain a high resistance and high wattage resistor (25-1000 ohms and 25 watts minimum). This resistor is not supplied with machine. **NEVER USE A SHORTING STRAP FOR THIS PROCEDURE.**
5. Locate the four capacitor terminals (large hex head cap screws) shown in Figure D.1. One pair at the top and one pair at the bottom of the Power Board.
6. Use electrically insulated gloves and insulated pliers. Hold body of the resistor and connect resistor leads across the two capacitor terminals. Hold resistor in place for 10 seconds. **DO NOT TOUCH CAPACITOR TERMINALS WITH YOUR BARE HANDS.**
7. Repeat discharge procedure for the capacitor on other two terminals.
8. Check voltage across terminals of all capacitors with a DC voltmeter. Polarity of capacitor terminals is marked on PC board above terminals. Voltage should be zero. If any voltage remains, repeat this capacitor discharge procedure.

FIGURE D.1 — LOCATION OF INPUT FILTER CAPACITOR TERMINALS.

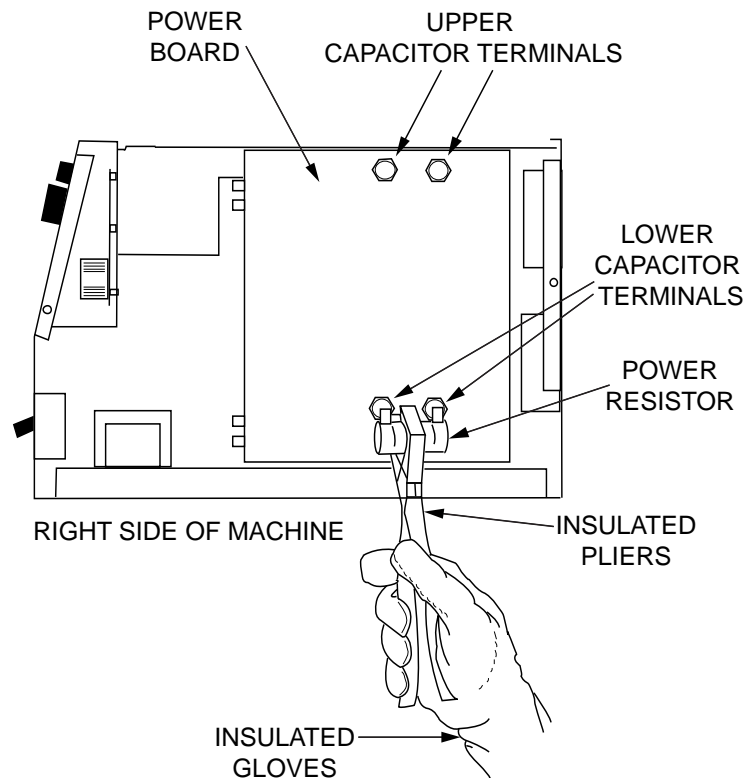

ES 275i



ROUTINE MAINTENANCE

1. Perform the following preventive maintenance procedures at least once every six months. It is good practice to keep a preventive maintenance record; a record tag attached to the machine works best.
2. Remove the machine wrap-around cover and perform the input filter capacitor discharge procedure (detail at the beginning of this chapter).
3. Keeping the machine clean will result in cooler operation and higher reliability. Be sure to clean the following areas with a low pressure air stream. See figure D.2 for component locations.
 - Power and control printed circuit boards
 - Power switch
 - Main transformer
 - Input rectifier
 - Heat sink fins
 - Input Filter Capacitors
 - Output Terminals
4. Examine capacitors for leakage or oozing. Replace if needed.
5. Examine the sheet metal case for dents or breakage. Repair the case as required. Keep the case in good condition to ensure that high voltage parts are protected and correct spacings are maintained. All external sheet metal screws must be in place to assure case strength and electrical ground continuity.
6. Check electrical ground continuity. Using an ohmmeter, measure resistance between either output terminal and an unpainted surface of the machine case. (See Figure D.2 for locations.) Meter reading should be 500,000 ohms or more. If meter reading is less than 500,000 ohms, check for electrical components that are not properly insulated from the case. Correct insulation if needed.
7. Replace machine cover and screws.

FIGURE D.2 — LOCATION OF MAINTENANCE COMPONENTS.

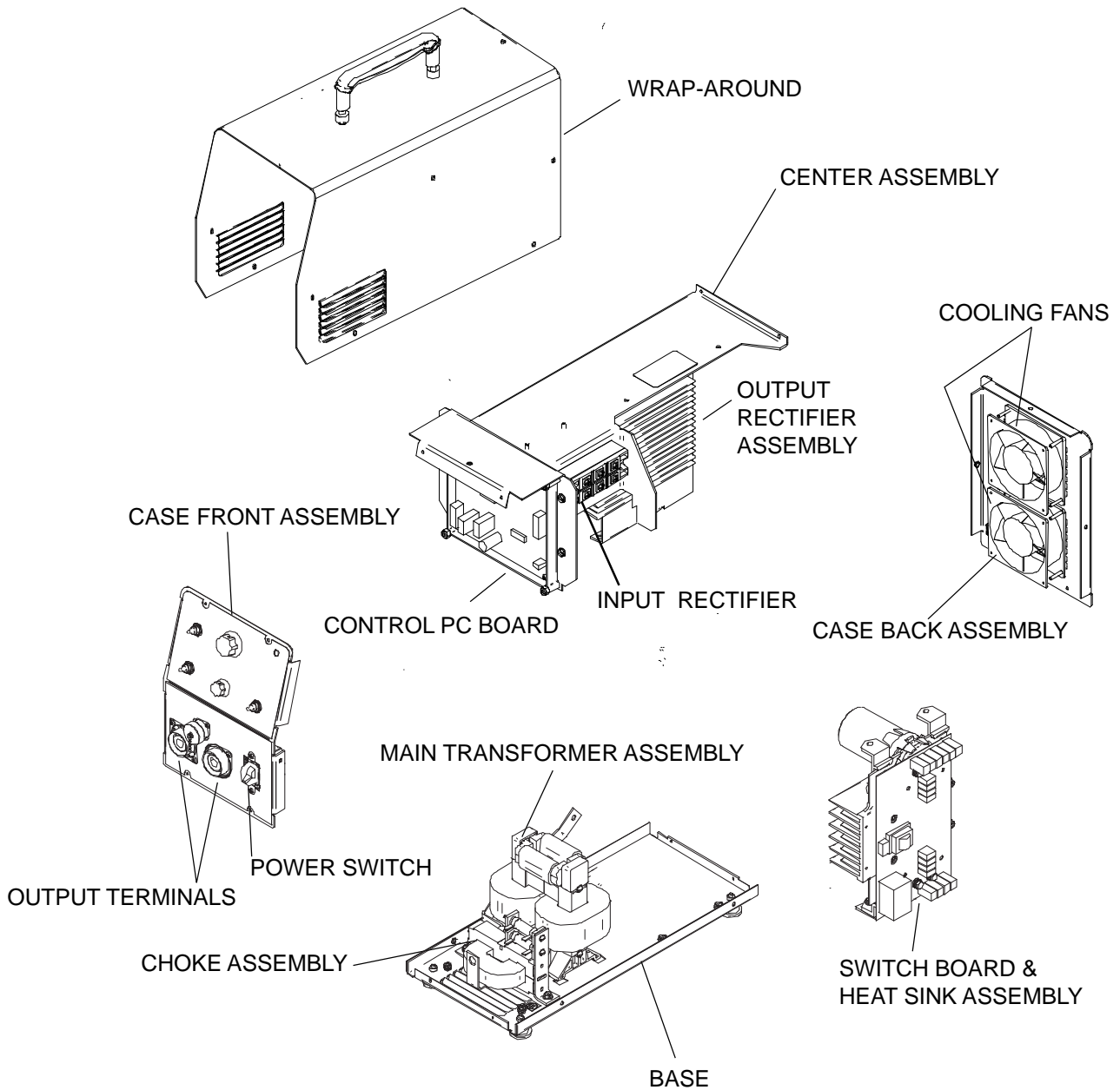

HOW TO USE TROUBLESHOOTING GUIDE

WARNING

Service and Repair should only be performed by Trained Personnel. Unauthorized repairs performed on this equipment may result in danger to the technician and machine operator and will invalidate your factory warranty. For your safety and to avoid Electrical Shock, please observe all safety notes and precautions detailed throughout this manual.

This Troubleshooting Guide is provided to help you locate and repair possible machine malfunctions. Simply follow the three-step procedure listed below.

Step 1. LOCATE PROBLEM (SYMPTOM).

Look under the column labeled "PROBLEM (SYMPTOMS)". This column describes possible symptoms that the machine may exhibit. Find the listing that best describes the symptom that the machine is exhibiting.

Step 2. POSSIBLE CAUSE.

The second column labeled "POSSIBLE CAUSE" lists the obvious external possibilities that may contribute to the machine symptom.

Step 3. RECOMMENDED COURSE OF ACTION

This column provides a course of action for the Possible Cause, generally it states to contact your local Authorized Field Service Facility.

If you do not understand or are unable to perform the Recommended Course of Action safely, contact your local Authorized Field Service Facility.

CAUTION

If for any reason you do not understand the test procedures or are unable to perform the tests/repairs safely, contact your **Local Authorized Field Service Facility** for technical troubleshooting assistance before you proceed.

PC BOARD TROUBLESHOOTING PROCEDURES

⚠ WARNING

ELECTRIC SHOCK can kill. Have an electrician install and service this equipment. Turn the input power OFF at the fuse box before working on equipment. Do not touch electrically hot parts.

CAUTION: Sometimes machine failures appear to be due to PC board failures. These problems can sometimes be traced to poor electrical connections. To avoid problems when troubleshooting and replacing PC boards, please use the following procedure:

1. Determine to the best of your technical ability that the PC board is the most likely component causing the failure symptom.
2. Check for loose connections at the PC board to assure that the PC board is properly connected.
3. If the problem persists, replace the suspect PC board using standard practices to avoid static electrical damage and electrical shock. Read the warning inside the static resistant bag and perform the following procedures:



ATTENTION
Static-Sensitive
Devices
Handle only at
Static-Safe
Workstations

Reusable
Container
Do Not Destroy

P.C. Board can be damaged by static electricity.

- Remove your body's static charge before opening the static-shielding bag. Wear an anti-static wrist strap. For safety, use a 1 Meg ohm resistive cord connected to a grounded part of the equipment frame.

- If you don't have a wrist strap, touch an unpainted, grounded, part of the

equipment frame. Keep touching the frame to prevent static build-up. Be sure not to touch any electrically live parts at the same time.

- Tools which come in contact with the P.C. Board must be either conductive, anti-static or static-dissipate.

- Remove the P.C. Board from the static-shielding bag and place it directly into the equipment. Don't set the P.C. Board on or near paper, plastic or cloth which could have a static charge. If the P.C. Board can't be installed immediately, put it back in the static-shielding bag.

- If the P.C. Board uses protective shorting jumpers, don't remove them until installation is complete.

- If you return a P.C. Board for credit, it must be in the static-shielding bag. This will prevent further damage and allow proper failure analysis.

4. Test the machine to determine if the failure symptom has been corrected by the replacement PC board.

NOTE: It is desirable to have a spare (known good) PC board available for PC board troubleshooting.

NOTE: Allow the machine to heat up so that all electrical components can reach their operating temperature.

5. Remove the replacement PC board and substitute it with the original PC board to recreate the original problem.

a. If the original problem does not reappear by substituting the original board, then the PC board was not the problem. Continue to look for bad connections in the control wiring harness, junction blocks, and terminal strips.

b. If the original problem is recreated by the substitution of the original board, then the PC board was the problem. Reinstall the replacement PC board and test the machine.

6. Always indicate that this procedure was followed when warranty reports are to be submitted.

NOTE: Following this procedure and writing on the warranty report, "INSTALLED AND SWITCHED PC BOARDS TO VERIFY PROBLEM," will help avoid denial of legitimate PC board warranty claims.

Observe all Safety Guidelines detailed throughout this manual

PROBLEMS (SYMPTOMS)	POSSIBLE CAUSE	RECOMMENDED COURSE OF ACTION
OUTPUT PROBLEMS		
Major physical or electrical damage is observed when cover wrap-around is removed.		
The machine is dead - no output.	<ol style="list-style-type: none"> 1. The input power switch must be in the ON position. 2. Make sure the input voltage is correct for the machine. 3. If the machine is set for single-phase operation, inspect to assure that the WHITE and BLACK leads are connected properly and the RED lead is not connected and is insulated. 4. Check that the input voltage set-up switch and jumper "A" (the reconnect auxiliary jumper) are in the proper position for the input voltage being applied. Refer to Input Voltage Reconnect Procedure in the Installation Chapter. 5. Check continuity of the 0.6-amp slow blow fuse located on the reconnect panel. 	If all recommended possible areas of misadjustment have been checked and the problem persists, Contact your local Authorized Field Service Facility.
No output but the fan operates normally.	<ol style="list-style-type: none"> 1. If the machine has not been used for a long time and is connected for 380 VAC or higher, the capacitors may need "conditioning". See Input Filter Capacitor Conditioning. 2. The machine may be overheated. Check the thermal indicator light. Wait for the machine to cool and the thermostats to reset. 	

⚠ CAUTION

If for any reason you do not understand the test procedures or are unable to perform the tests/repairs safely, contact your local authorized field service facility for technical troubleshooting assistance before you proceed.

Observe all Safety Guidelines detailed throughout this manual

PROBLEMS (SYMPTOMS)	POSSIBLE CAUSE	RECOMMENDED COURSE OF ACTION
OUTPUT PROBLEMS		
<p>Output turns on momentarily, then switches off and repeats cycle.</p>	<ol style="list-style-type: none"> 1. Check the input voltages and reconnection procedures. Make sure the input voltage is correct for the machine. See <i>Input Voltage Reconnect Procedure</i>. 2. Check or replace remote control device. (If used) 	
<p>Remote output control not functioning. The machine operates normally on LOCAL control.</p>	<ol style="list-style-type: none"> 1. Make sure the Local/Remote switch (S3) is in the REMOTE position. 2. The remote control device may be faulty. Replace. 3. The Local/Remote switch must be in the LOCAL position unless a remote control device is attached to the remote receptacle. 	<p>If all recommended possible areas of misadjustment have been checked and the problem persists, Contact your local Authorized Field Service Facility.</p>

⚠ CAUTION

If for any reason you do not understand the test procedures or are unable to perform the tests/repairs safely, contact your local authorized field service facility for technical troubleshooting assistance before you proceed.

ES 275i



Observe all Safety Guidelines detailed throughout this manual

PROBLEMS (SYMPTOMS)	POSSIBLE CAUSE	RECOMMENDED COURSE OF ACTION
OUTPUT PROBLEMS		
<p>No output - Main input fuses open, indicating excessive current draw.</p>	<ol style="list-style-type: none"> 1. Inspect input leads for possible shorts or grounds or mis-connections. 2. Install new fuses and reapply power. If fuses open again, consult a Authorized Field Service Facility. 	
<p>The machine operates normally when connected for 200 - 230VAC input. There is no output when the machine is connected to 380VAC or higher.</p>	<ol style="list-style-type: none"> 1. Check the input voltage and input voltage reconnect procedures. See Installation Section of this manual. 	<p>If all recommended possible areas of misadjustment have been checked and the problem persists, Contact your local Authorized Field Service Facility.</p>

⚠ CAUTION

If for any reason you do not understand the test procedures or are unable to perform the tests/repairs safely, contact your local authorized field service facility for technical troubleshooting assistance before you proceed.

ES 275i



Observe all Safety Guidelines detailed throughout this manual

PROBLEMS (SYMPTOMS)	POSSIBLE CAUSE	RECOMMENDED COURSE OF ACTION
OUTPUT PROBLEMS		
<p>The machine will not produce more than 200 amps.</p>	<ol style="list-style-type: none"> 1. This may be normal operation. If the output current exceeds 300 amps, an electronic protection circuit will reduce the current to less than 200 amps. The machine will continue to produce this low current until the protection circuit is reset. Reset occurs when the output load is removed. 2. Check the input voltage and input voltage reconnect procedures. See Input Voltage Reconnect Procedure. 3. Check for loose or faulty welding cables. 	<p>If all recommended possible areas of misadjustment have been checked and the problem persists, Contact your local Authorized Field Service Facility.</p>

 **CAUTION**

If for any reason you do not understand the test procedures or are unable to perform the tests/repairs safely, contact your local authorized field service facility for technical troubleshooting assistance before you proceed.

ES 275i



Observe all Safety Guidelines detailed throughout this manual

PROBLEMS (SYMPTOMS)	POSSIBLE CAUSE	RECOMMENDED COURSE OF ACTION
WELDING PROBLEMS		
<p>Poor welding, weld settings drift, or output power is low.</p>	<ol style="list-style-type: none"> 1. Make sure the machine settings are correct for the weld process being used. 2. Check machine performance on LOCAL control. If OK then the remote control device may be faulty. Check or replace. 3. Check the input voltages and input voltage reconnect procedures. See Installation Section of this manual. 4. Check for loose or faulty welding cables. 	<p>If all recommended possible areas of misadjustment have been checked and the problem persists, Contact your local Authorized Field Service Facility.</p>
<p>Poor stick electrode welding performance. The arc pops out.</p>	<ol style="list-style-type: none"> 1. Check for loose or faulty welding cables. 2. Is the electrode DRY? Try welding with another electrode from a different container. Make sure you have the correct electrode for the application. 3. Make sure the machine settings are correct for the weld process being used. 	
<p>The thermal light and fan keep turning on and off.</p>	<ol style="list-style-type: none"> 1. Check the input voltage section. 2. Check for blockage of vents, which restricts air flow into or out of the machine. 	

⚠ CAUTION

If for any reason you do not understand the test procedures or are unable to perform the tests/repairs safely, contact your local authorized field service facility for technical troubleshooting assistance before you proceed.

ES 275i



WIRING DIAGRAM- CODE: 10994

WIRING DIAGRAM RED-D-ARC ES275i

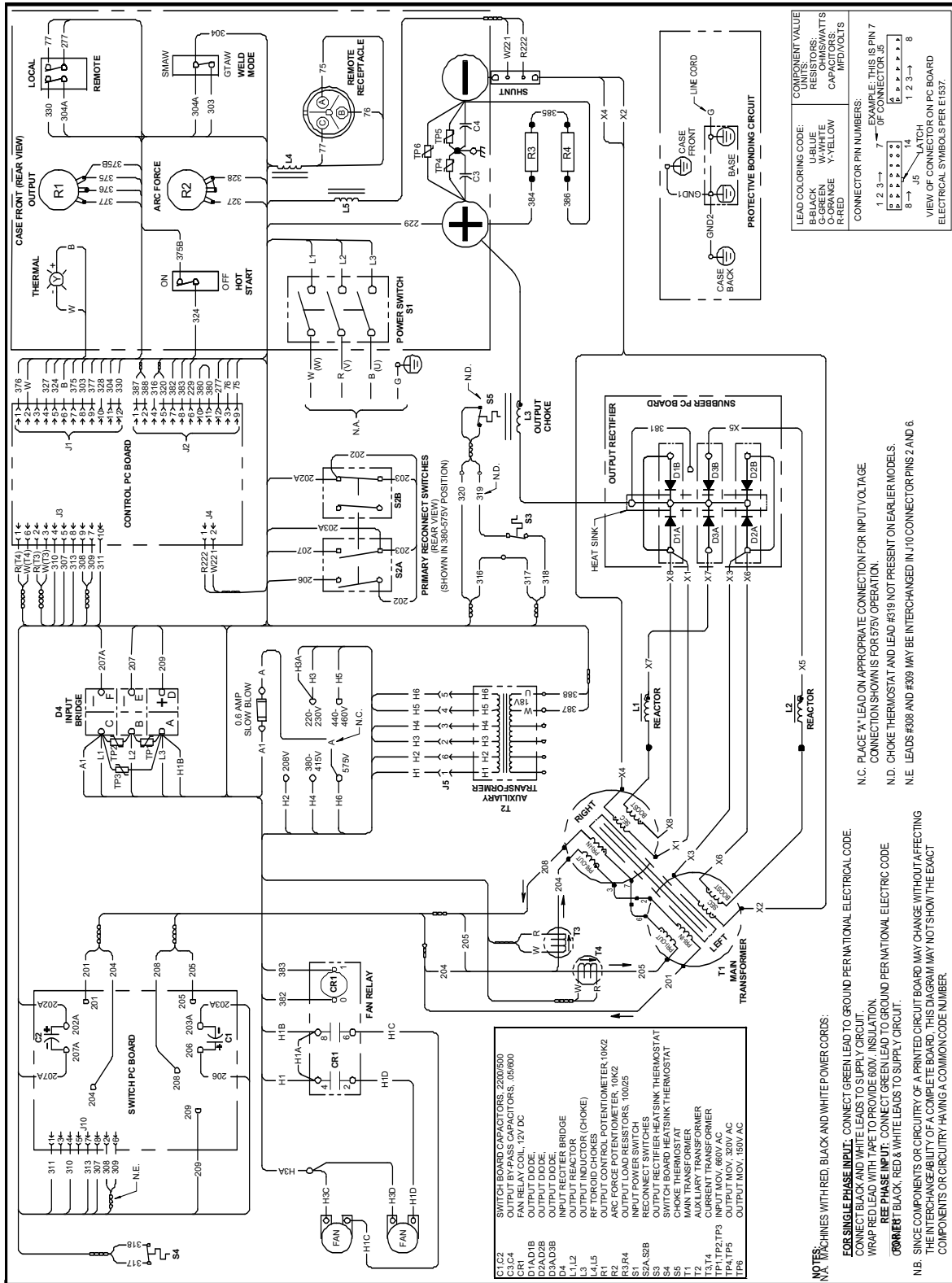

G4365-2

NOTE: This diagram is for reference only. It may not be accurate for all machines covered by this manual. The specific diagram for a particular code is pasted inside the machine on one of the enclosure panels. If the diagram is illegible, write to the Service Department for a replacement. Give the equipment code number.

WIRING DIAGRAM- CODE: 11166, 11223

WIRING DIAGRAM - RED-D-ARC ES275i

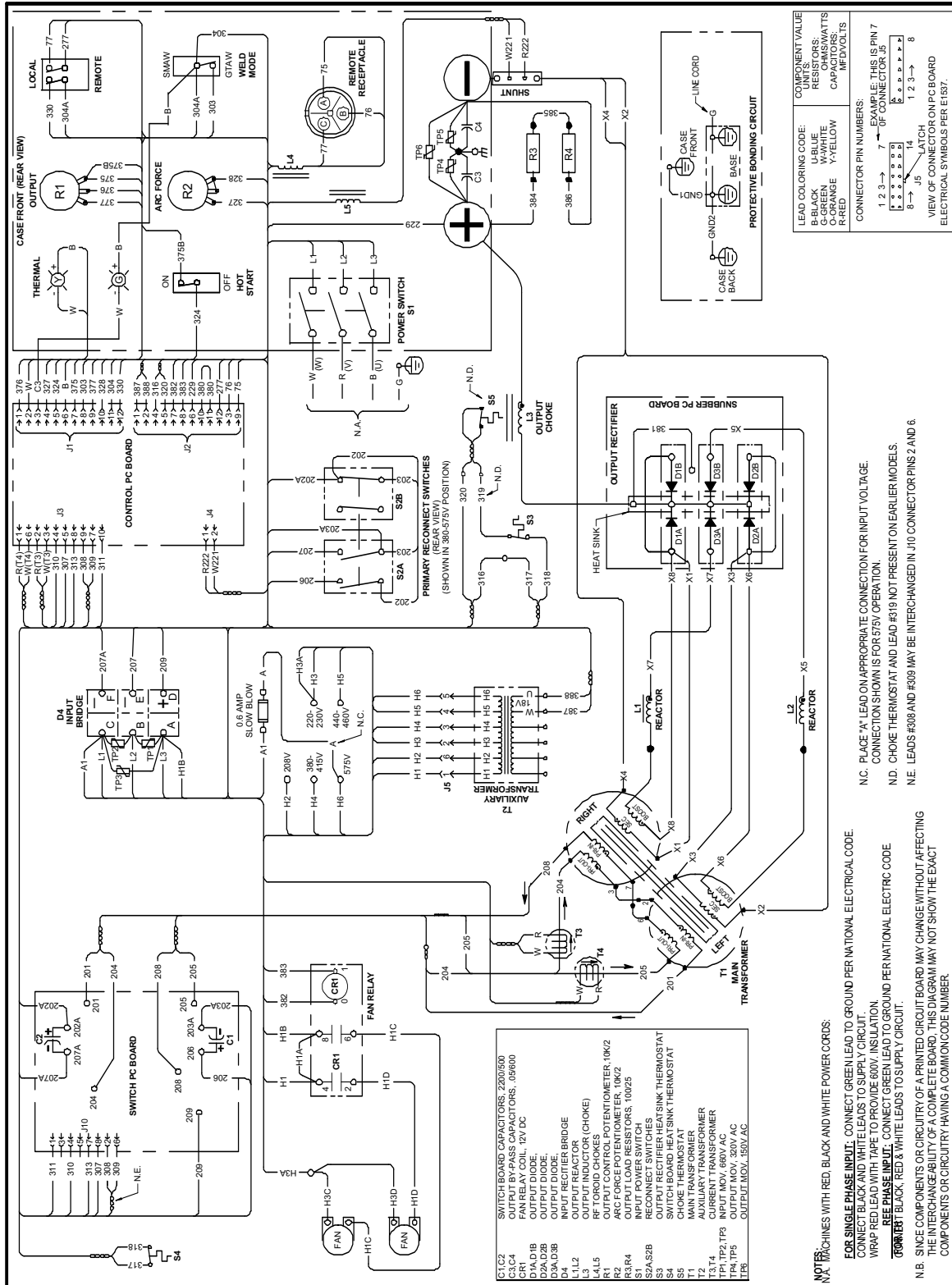

G4365-4

NOTE: This diagram is for reference only. It may not be accurate for all machines covered by this manual. The specific diagram for a particular code is pasted inside the machine on one of the enclosure panels. If the diagram is illegible, write to the Service Department for a replacement. Give the equipment code number.

WIRING DIAGRAM- CODES: 11266

WIRING DIAGRAM - RED-D-ARC ES275i

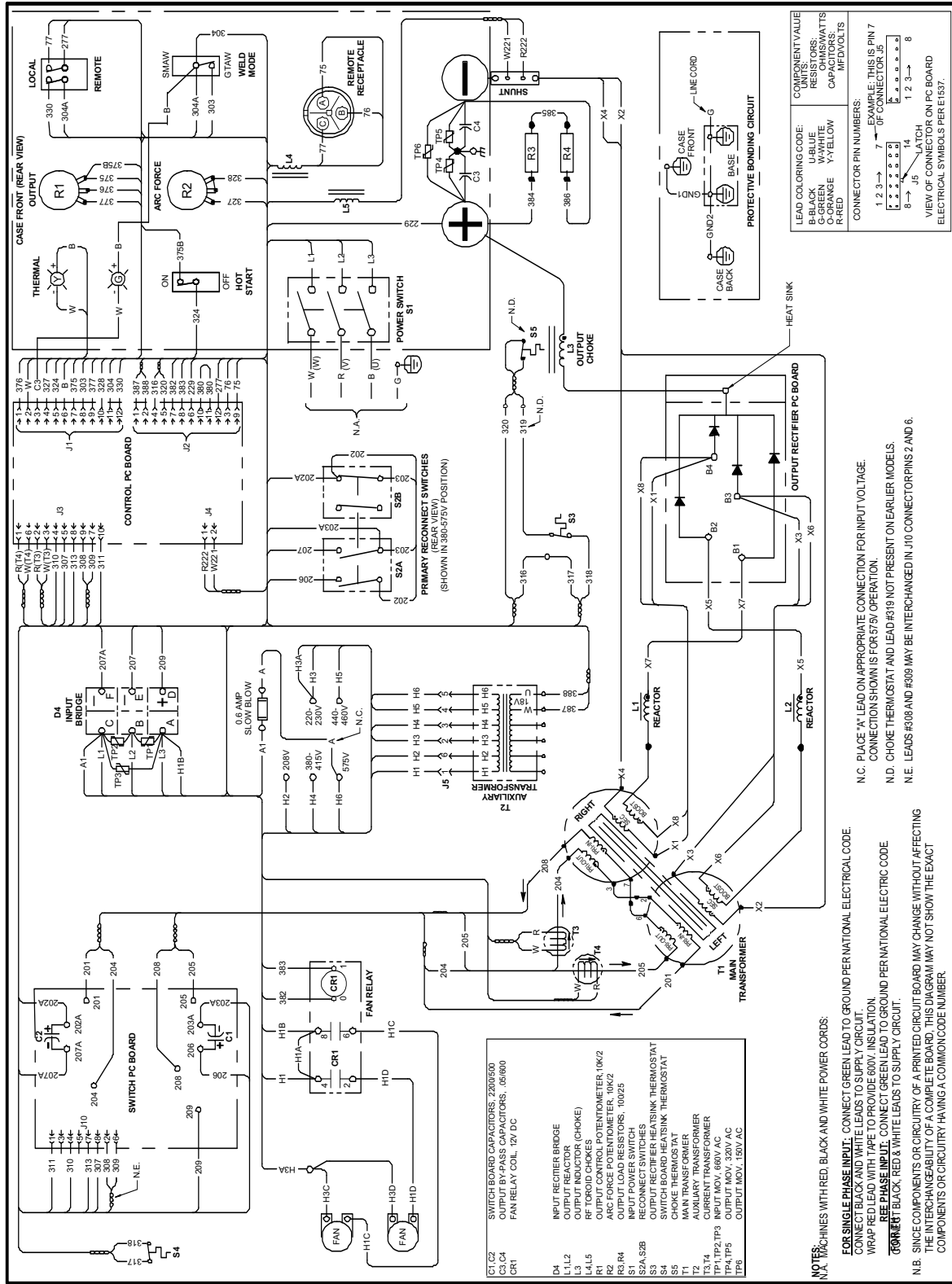

G4365-5

NOTE: This diagram is for reference only. It may not be accurate for all machines covered by this manual. The specific diagram for a particular code is pasted inside the machine on one of the enclosure panels. If the diagram is illegible, write to the Service Department for a replacement. Give the equipment code number.

DIMENSION PRINT

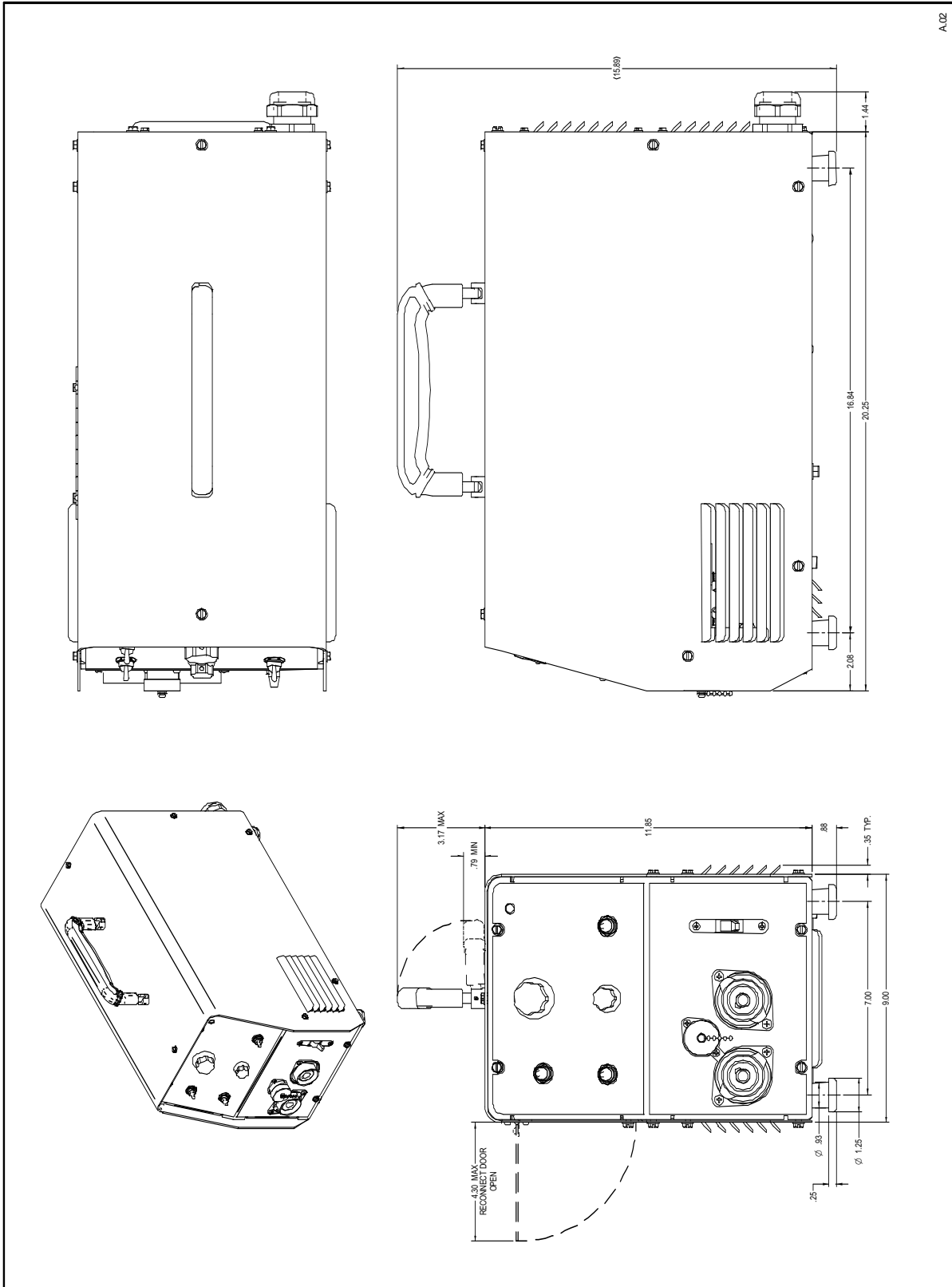

A.02
L11981

			
WARNING	<ul style="list-style-type: none"> ● Do not touch electrically live parts or electrode with skin or wet clothing. ● Insulate yourself from work and ground. 	<ul style="list-style-type: none"> ● Keep flammable materials away. 	<ul style="list-style-type: none"> ● Wear eye, ear and body protection.
Spanish AVISO DE PRECAUCION	<ul style="list-style-type: none"> ● No toque las partes o los electrodos bajo carga con la piel o ropa mojada. ● Aíslese del trabajo y de la tierra. 	<ul style="list-style-type: none"> ● Mantenga el material combustible fuera del área de trabajo. 	<ul style="list-style-type: none"> ● Protéjase los ojos, los oídos y el cuerpo.
French ATTENTION	<ul style="list-style-type: none"> ● Ne laissez ni la peau ni des vêtements mouillés entrer en contact avec des pièces sous tension. ● Isolez-vous du travail et de la terre. 	<ul style="list-style-type: none"> ● Gardez à l'écart de tout matériel inflammable. 	<ul style="list-style-type: none"> ● Protégez vos yeux, vos oreilles et votre corps.
German WARNUNG	<ul style="list-style-type: none"> ● Berühren Sie keine stromführenden Teile oder Elektroden mit Ihrem Körper oder feuchter Kleidung! ● Isolieren Sie sich von den Elektroden und dem Erdboden! 	<ul style="list-style-type: none"> ● Entfernen Sie brennbares Material! 	<ul style="list-style-type: none"> ● Tragen Sie Augen-, Ohren- und Körperschutz!
Portuguese ATENÇÃO	<ul style="list-style-type: none"> ● Não toque partes elétricas e electrodos com a pele ou roupa molhada. ● Isole-se da peça e terra. 	<ul style="list-style-type: none"> ● Mantenha inflamáveis bem guardados. 	<ul style="list-style-type: none"> ● Use proteção para a vista, ouvido e corpo.
Japanese 注意事項	<ul style="list-style-type: none"> ● 通電中の電気部品、又は溶材にヒフやぬれた布で触れないこと。 ● 施工物やアースから身体が絶縁されている様にして下さい。 	<ul style="list-style-type: none"> ● 燃えやすいものの側での溶接作業は絶対にしてはなりません。 	<ul style="list-style-type: none"> ● 目、耳及び身体に保護具をして下さい。
Chinese 警告	<ul style="list-style-type: none"> ● 皮膚或濕衣物切勿接觸帶電部件及鎢條。 ● 使你自已與地面和工件絕緣。 	<ul style="list-style-type: none"> ● 把一切易燃物品移離工作場所。 	<ul style="list-style-type: none"> ● 佩戴眼、耳及身體勞動保護用具。
Korean 위험	<ul style="list-style-type: none"> ● 전도체나 용접봉을 젖은 헝겍 또는 피부로 절대 접촉치 마십시오. ● 모재와 접지를 접촉치 마십시오. 	<ul style="list-style-type: none"> ● 인화성 물질을 접근시키지 마십시오. 	<ul style="list-style-type: none"> ● 눈, 귀와 몸에 보호장구를 착용하십시오.
Arabic تحذير	<ul style="list-style-type: none"> ● لا تلمس الاجزاء التي يسري فيها التيار الكهربائي أو الألكترود بجسد الجسم أو بالملابس المبللة بالماء. ● ضع عازلا على جسمك خلال العمل. 	<ul style="list-style-type: none"> ● ضع المواد القابلة للاشتعال في مكان بعيد. 	<ul style="list-style-type: none"> ● ضع أدوات وملابس واقية على عينيك وأذنيك وجسمك.

READ AND UNDERSTAND THE MANUFACTURER'S INSTRUCTION FOR THIS EQUIPMENT AND THE CONSUMABLES TO BE USED AND FOLLOW YOUR EMPLOYER'S SAFETY PRACTICES.

SE RECOMIENDA LEER Y ENTENDER LAS INSTRUCCIONES DEL FABRICANTE PARA EL USO DE ESTE EQUIPO Y LOS CONSUMIBLES QUE VA A UTILIZAR, SIGA LAS MEDIDAS DE SEGURIDAD DE SU SUPERVISOR.

LISEZ ET COMPRENEZ LES INSTRUCTIONS DU FABRICANT EN CE QUI REGARDE CET EQUIPMENT ET LES PRODUITS A ETRE EMPLOYES ET SUIVEZ LES PROCEDURES DE SECURITE DE VOTRE EMPLOYEUR.

LESEN SIE UND BEFOLGEN SIE DIE BETRIEBSANLEITUNG DER ANLAGE UND DEN ELEKTRODENEINSATZ DES HERSTELLERS. DIE UNFALLVERHÜTUNGSVORSCHRIFTEN DES ARBEITGEBERS SIND EBENFALLS ZU BEACHTEN.

<ul style="list-style-type: none"> ● Keep your head out of fumes. ● Use ventilation or exhaust to remove fumes from breathing zone. 	<ul style="list-style-type: none"> ● Turn power off before servicing. 	<ul style="list-style-type: none"> ● Do not operate with panel open or guards off. 	WARNING
<ul style="list-style-type: none"> ● Los humos fuera de la zona de respiración. ● Mantenga la cabeza fuera de los humos. Utilice ventilación o aspiración para gases. 	<ul style="list-style-type: none"> ● Desconectar el cable de alimentación de poder de la máquina antes de iniciar cualquier servicio. 	<ul style="list-style-type: none"> ● No operar con panel abierto o guardas quitadas. 	Spanish AVISO DE PRECAUCION
<ul style="list-style-type: none"> ● Gardez la tête à l'écart des fumées. ● Utilisez un ventilateur ou un aspirateur pour ôter les fumées des zones de travail. 	<ul style="list-style-type: none"> ● Débranchez le courant avant l'entretien. 	<ul style="list-style-type: none"> ● N'opérez pas avec les panneaux ouverts ou avec les dispositifs de protection enlevés. 	French ATTENTION
<ul style="list-style-type: none"> ● Vermeiden Sie das Einatmen von Schweißrauch! ● Sorgen Sie für gute Be- und Entlüftung des Arbeitsplatzes! 	<ul style="list-style-type: none"> ● Strom vor Wartungsarbeiten abschalten! (Netzstrom völlig öffnen; Maschine anhalten!) 	<ul style="list-style-type: none"> ● Anlage nie ohne Schutzgehäuse oder Innenschutzverkleidung in Betrieb setzen! 	German WARNUNG
<ul style="list-style-type: none"> ● Mantenha seu rosto da fumaça. ● Use ventilação e exaustão para remover fumo da zona respiratória. 	<ul style="list-style-type: none"> ● Não opere com as tampas removidas. ● Desligue a corrente antes de fazer serviço. ● Não toque as partes elétricas nuas. 	<ul style="list-style-type: none"> ● Mantenha-se afastado das partes moventes. ● Não opere com os painéis abertos ou guardas removidas. 	Portuguese ATENÇÃO
<ul style="list-style-type: none"> ● ヒュームから頭を離すようにして下さい。 ● 換気や排煙に十分留意して下さい。 	<ul style="list-style-type: none"> ● メンテナンス・サービスに取りかかる際には、まず電源スイッチを必ず切ってください。 	<ul style="list-style-type: none"> ● パネルやカバーを取り外したまま機械操作をしないで下さい。 	Japanese 注意事項
<ul style="list-style-type: none"> ● 頭部遠離煙霧。 ● 在呼吸區使用通風或排風器除煙。 	<ul style="list-style-type: none"> ● 維修前切斷電源。 	<ul style="list-style-type: none"> ● 儀表板打開或沒有安全罩時不準作業。 	Chinese 警告
<ul style="list-style-type: none"> ● 얼굴로부터 용접가스를 멀리하십시오. ● 호흡지역으로부터 용접가스를 제거하기 위해 가스제거기나 통풍기를 사용하십시오. 	<ul style="list-style-type: none"> ● 보수전에 전원을 차단하십시오. 	<ul style="list-style-type: none"> ● 판넬이 열린 상태로 작동치 마십시오. 	Korean 위험
<ul style="list-style-type: none"> ● ابعد رأسك بعيداً عن الدخان. ● استعمل التهوية أو جهاز ضغط الدخان للخارج لكي تبعد الدخان عن المنطقة التي تتنفس فيها. 	<ul style="list-style-type: none"> ● أقطع التيار الكهربائي قبل القيام بأية صيانة. 	<ul style="list-style-type: none"> ● لا تشغيل هذا الجهاز اذا كانت الاغطية الحديدية الواقية ليست عليه. 	Arabic تحذير

LEIA E COMPREENDA AS INSTRUÇÕES DO FABRICANTE PARA ESTE EQUIPAMENTO E AS PARTES DE USO, E SIGA AS PRÁTICAS DE SEGURANÇA DO EMPREGADOR.

使う機械や溶材のメーカーの指示書をよく読み、まず理解して下さい。そして貴社の安全規定に従って下さい。

請詳細閱讀並理解製造廠提供的說明以及應該使用的銀焊材料，並請遵守貴方的有閣勞動保護規定。

이 제품에 동봉된 작업지침서를 숙지하시고 귀사의 작업자 안전수칙을 준수하시기 바랍니다.

اقرأ بتمعن وافهم تعليمات المصنع المنتج لهذه المعدات والمواد قبل استعمالها واتبع تعليمات الوقاية لصاحب العمل.



• World's Leader in Welding and Cutting Products •

• Sales and Service through Subsidiaries and Distributors Worldwide •

Cleveland, Ohio 44117-1199 U.S.A. TEL: 216.481.8100 FAX: 216.486.1751 WEB SITE: www.lincolnelectric.com