

LN-35 CV/CC SEMIAUTOMATIC WIRE FEEDER

IM812-A

January, 2005

For use with machines having Code Numbers: 11029, 11250

Safety Depends on You

Lincoln arc welding and cutting equipment is designed and built with safety in mind. However, your overall safety can be increased by proper installation ... and thoughtful operation on your part. **DO NOT INSTALL, OPERATE OR REPAIR THIS EQUIPMENT WITHOUT READING THIS MANUAL AND THE SAFETY PRECAUTIONS CONTAINED THROUGHOUT.** And, most importantly, think before you act and be careful.

OPERATOR'S MANUAL



LINCOLN[®]
ELECTRIC

Copyright © 2005 Lincoln Global Inc.

- World's Leader in Welding and Cutting Products •
- Sales and Service through Subsidiaries and Distributors Worldwide •

Cleveland, Ohio 44117-1199 U.S.A. TEL: 216.481.8100 FAX: 216.486.1751 WEB SITE: www.lincolnelectric.com

⚠ WARNING

⚠ CALIFORNIA PROPOSITION 65 WARNINGS ⚠

Diesel engine exhaust and some of its constituents are known to the State of California to cause cancer, birth defects, and other reproductive harm.

The Above For Diesel Engines

The engine exhaust from this product contains chemicals known to the State of California to cause cancer, birth defects, or other reproductive harm.

The Above For Gasoline Engines

ARC WELDING CAN BE HAZARDOUS. PROTECT YOURSELF AND OTHERS FROM POSSIBLE SERIOUS INJURY OR DEATH. KEEP CHILDREN AWAY. PACEMAKER WEARERS SHOULD CONSULT WITH THEIR DOCTOR BEFORE OPERATING.

Read and understand the following safety highlights. For additional safety information, it is strongly recommended that you purchase a copy of "Safety in Welding & Cutting - ANSI Standard Z49.1" from the American Welding Society, P.O. Box 351040, Miami, Florida 33135 or CSA Standard W117.2-1974. A Free copy of "Arc Welding Safety" booklet E205 is available from the Lincoln Electric Company, 22801 St. Clair Avenue, Cleveland, Ohio 44117-1199.

BE SURE THAT ALL INSTALLATION, OPERATION, MAINTENANCE AND REPAIR PROCEDURES ARE PERFORMED ONLY BY QUALIFIED INDIVIDUALS.



FOR ENGINE powered equipment.

1.a. Turn the engine off before troubleshooting and maintenance work unless the maintenance work requires it to be running.



1.b. Operate engines in open, well-ventilated areas or vent the engine exhaust fumes outdoors.



1.c. Do not add the fuel near an open flame welding arc or when the engine is running. Stop the engine and allow it to cool before refueling to prevent spilled fuel from vaporizing on contact with hot engine parts and igniting. Do not spill fuel when filling tank. If fuel is spilled, wipe it up and do not start engine until fumes have been eliminated.

1.d. Keep all equipment safety guards, covers and devices in position and in good repair. Keep hands, hair, clothing and tools away from V-belts, gears, fans and all other moving parts when starting, operating or repairing equipment.

1.e. In some cases it may be necessary to remove safety guards to perform required maintenance. Remove guards only when necessary and replace them when the maintenance requiring their removal is complete. Always use the greatest care when working near moving parts.



1.f. Do not put your hands near the engine fan. Do not attempt to override the governor or idler by pushing on the throttle control rods while the engine is running.

1.g. To prevent accidentally starting gasoline engines while turning the engine or welding generator during maintenance work, disconnect the spark plug wires, distributor cap or magneto wire as appropriate.

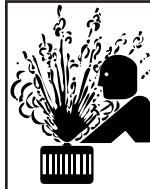

1.h. To avoid scalding, do not remove the radiator pressure cap when the engine is hot.



ELECTRIC AND MAGNETIC FIELDS may be dangerous

2.a. Electric current flowing through any conductor causes localized Electric and Magnetic Fields (EMF). Welding current creates EMF fields around welding cables and welding machines

2.b. EMF fields may interfere with some pacemakers, and welders having a pacemaker should consult their physician before welding.

2.c. Exposure to EMF fields in welding may have other health effects which are now not known.

2.d. All welders should use the following procedures in order to minimize exposure to EMF fields from the welding circuit:

2.d.1. Route the electrode and work cables together - Secure them with tape when possible.

2.d.2. Never coil the electrode lead around your body.

2.d.3. Do not place your body between the electrode and work cables. If the electrode cable is on your right side, the work cable should also be on your right side.

2.d.4. Connect the work cable to the workpiece as close as possible to the area being welded.

2.d.5. Do not work next to welding power source.

Mar '95



ELECTRIC SHOCK can kill.

- 3.a. The electrode and work (or ground) circuits are electrically "hot" when the welder is on. Do not touch these "hot" parts with your bare skin or wet clothing. Wear dry, hole-free gloves to insulate hands.
- 3.b. Insulate yourself from work and ground using dry insulation. Make certain the insulation is large enough to cover your full area of physical contact with work and ground.
- In addition to the normal safety precautions, if welding must be performed under electrically hazardous conditions (in damp locations or while wearing wet clothing; on metal structures such as floors, gratings or scaffolds; when in cramped positions such as sitting, kneeling or lying, if there is a high risk of unavoidable or accidental contact with the workpiece or ground) use the following equipment:**
- Semiautomatic DC Constant Voltage (Wire) Welder.
 - DC Manual (Stick) Welder.
 - AC Welder with Reduced Voltage Control.
- 3.c. In semiautomatic or automatic wire welding, the electrode, electrode reel, welding head, nozzle or semiautomatic welding gun are also electrically "hot".
- 3.d. Always be sure the work cable makes a good electrical connection with the metal being welded. The connection should be as close as possible to the area being welded.
- 3.e. Ground the work or metal to be welded to a good electrical (earth) ground.
- 3.f. Maintain the electrode holder, work clamp, welding cable and welding machine in good, safe operating condition. Replace damaged insulation.
- 3.g. Never dip the electrode in water for cooling.
- 3.h. Never simultaneously touch electrically "hot" parts of electrode holders connected to two welders because voltage between the two can be the total of the open circuit voltage of both welders.
- 3.i. When working above floor level, use a safety belt to protect yourself from a fall should you get a shock.
- 3.j. Also see Items 6.c. and 8.



ARC RAYS can burn.

- 4.a. Use a shield with the proper filter and cover plates to protect your eyes from sparks and the rays of the arc when welding or observing open arc welding. Headshield and filter lens should conform to ANSI Z87.1 standards.
- 4.b. Use suitable clothing made from durable flame-resistant material to protect your skin and that of your helpers from the arc rays.
- 4.c. Protect other nearby personnel with suitable, non-flammable screening and/or warn them not to watch the arc nor expose themselves to the arc rays or to hot spatter or metal.



FUMES AND GASES can be dangerous.

- 5.a. Welding may produce fumes and gases hazardous to health. Avoid breathing these fumes and gases. When welding, keep your head out of the fume. Use enough ventilation and/or exhaust at the arc to keep fumes and gases away from the breathing zone. **When welding with electrodes which require special ventilation such as stainless or hard facing (see instructions on container or MSDS) or on lead or cadmium plated steel and other metals or coatings which produce highly toxic fumes, keep exposure as low as possible and below Threshold Limit Values (TLV) using local exhaust or mechanical ventilation. In confined spaces or in some circumstances, outdoors, a respirator may be required. Additional precautions are also required when welding on galvanized steel.**
- 5.b. Do not weld in locations near chlorinated hydrocarbon vapors coming from degreasing, cleaning or spraying operations. The heat and rays of the arc can react with solvent vapors to form phosgene, a highly toxic gas, and other irritating products.
- 5.c. Shielding gases used for arc welding can displace air and cause injury or death. Always use enough ventilation, especially in confined areas, to insure breathing air is safe.
- 5.d. Read and understand the manufacturer's instructions for this equipment and the consumables to be used, including the material safety data sheet (MSDS) and follow your employer's safety practices. MSDS forms are available from your welding distributor or from the manufacturer.
- 5.e. Also see item 1.b.

Mar '95

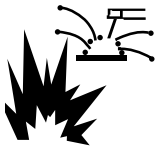

WELDING SPARKS can cause fire or explosion.

6.a. Remove fire hazards from the welding area. If this is not possible, cover them to prevent the welding sparks from starting a fire.

Remember that welding sparks and hot materials from welding can easily go through small cracks and openings to adjacent areas. Avoid welding near hydraulic lines. Have a fire extinguisher readily available.

- 6.b. Where compressed gases are to be used at the job site, special precautions should be used to prevent hazardous situations. Refer to "Safety in Welding and Cutting" (ANSI Standard Z49.1) and the operating information for the equipment being used.
- 6.c. When not welding, make certain no part of the electrode circuit is touching the work or ground. Accidental contact can cause overheating and create a fire hazard.
- 6.d. Do not heat, cut or weld tanks, drums or containers until the proper steps have been taken to insure that such procedures will not cause flammable or toxic vapors from substances inside. They can cause an explosion even though they have been "cleaned". For information, purchase "Recommended Safe Practices for the Preparation for Welding and Cutting of Containers and Piping That Have Held Hazardous Substances", AWS F4.1 from the American Welding Society (see address above).
- 6.e. Vent hollow castings or containers before heating, cutting or welding. They may explode.
- 6.f. Sparks and spatter are thrown from the welding arc. Wear oil free protective garments such as leather gloves, heavy shirt, cuffless trousers, high shoes and a cap over your hair. Wear ear plugs when welding out of position or in confined places. Always wear safety glasses with side shields when in a welding area.
- 6.g. Connect the work cable to the work as close to the welding area as practical. Work cables connected to the building framework or other locations away from the welding area increase the possibility of the welding current passing through lifting chains, crane cables or other alternate circuits. This can create fire hazards or overheat lifting chains or cables until they fail.
- 6.h. Also see item 1.c.

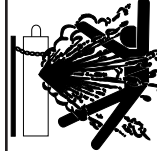

CYLINDER may explode if damaged.

7.a. Use only compressed gas cylinders containing the correct shielding gas for the process used and properly operating regulators designed for the gas and pressure used. All hoses, fittings, etc. should be suitable for the application and maintained in good condition.

- 7.b. Always keep cylinders in an upright position securely chained to an undercarriage or fixed support.
- 7.c. Cylinders should be located:
 - Away from areas where they may be struck or subjected to physical damage.
 - A safe distance from arc welding or cutting operations and any other source of heat, sparks, or flame.
- 7.d. Never allow the electrode, electrode holder or any other electrically "hot" parts to touch a cylinder.
- 7.e. Keep your head and face away from the cylinder valve outlet when opening the cylinder valve.
- 7.f. Valve protection caps should always be in place and hand tight except when the cylinder is in use or connected for use.
- 7.g. Read and follow the instructions on compressed gas cylinders, associated equipment, and CGA publication P-1, "Precautions for Safe Handling of Compressed Gases in Cylinders," available from the Compressed Gas Association 1235 Jefferson Davis Highway, Arlington, VA 22202.



FOR ELECTRICALLY powered equipment.

- 8.a. Turn off input power using the disconnect switch at the fuse box before working on the equipment.
- 8.b. Install equipment in accordance with the U.S. National Electrical Code, all local codes and the manufacturer's recommendations.
- 8.c. Ground the equipment in accordance with the U.S. National Electrical Code and the manufacturer's recommendations.

Mar '95

PRÉCAUTIONS DE SÛRETÉ

Pour votre propre protection lire et observer toutes les instructions et les précautions de sûreté spécifiques qui paraissent dans ce manuel aussi bien que les précautions de sûreté générales suivantes:

Sûreté Pour Soudage A L'Arc

1. Protégez-vous contre la secousse électrique:
 - a. Les circuits à l'électrode et à la pièce sont sous tension quand la machine à souder est en marche. Eviter toujours tout contact entre les parties sous tension et la peau nue ou les vêtements mouillés. Porter des gants secs et sans trous pour isoler les mains.
 - b. Faire très attention de bien s'isoler de la masse quand on soude dans des endroits humides, ou sur un plancher métallique ou des grilles métalliques, principalement dans les positions assis ou couché pour lesquelles une grande partie du corps peut être en contact avec la masse.
 - c. Maintenir le porte-électrode, la pince de masse, le câble de soudage et la machine à souder en bon et sûr état de fonctionnement.
 - d. Ne jamais plonger le porte-électrode dans l'eau pour le refroidir.
 - e. Ne jamais toucher simultanément les parties sous tension des porte-électrodes connectés à deux machines à souder parce que la tension entre les deux pinces peut être le total de la tension à vide des deux machines.
 - f. Si on utilise la machine à souder comme une source de courant pour soudage semi-automatique, ces précautions pour le porte-électrode s'appliquent aussi au pistolet de soudage.
2. Dans le cas de travail au dessus du niveau du sol, se protéger contre les chutes dans le cas où on recoit un choc. Ne jamais enrouler le câble-électrode autour de n'importe quelle partie du corps.
3. Un coup d'arc peut être plus sévère qu'un coup de soleil, donc:
 - a. Utiliser un bon masque avec un verre filtrant approprié ainsi qu'un verre blanc afin de se protéger les yeux du rayonnement de l'arc et des projections quand on soude ou quand on regarde l'arc.
 - b. Porter des vêtements convenables afin de protéger la peau de soudeur et des aides contre le rayonnement de l'arc.
 - c. Protéger l'autre personnel travaillant à proximité au soudage à l'aide d'écrans appropriés et non-inflammables.
4. Des gouttes de laitier en fusion sont émises de l'arc de soudage. Se protéger avec des vêtements de protection libres de l'huile, tels que les gants en cuir, chemise épaisse, pantalons sans revers, et chaussures montantes.

5. Toujours porter des lunettes de sécurité dans la zone de soudage. Utiliser des lunettes avec écrans latéraux dans les zones où l'on pique le laitier.
6. Eloigner les matériaux inflammables ou les recouvrir afin de prévenir tout risque d'incendie dû aux étincelles.
7. Quand on ne soude pas, poser la pince à un endroit isolé de la masse. Un court-circuit accidentel peut provoquer un échauffement et un risque d'incendie.
8. S'assurer que la masse est connectée le plus près possible de la zone de travail qu'il est pratique de le faire. Si on place la masse sur la charpente de la construction ou d'autres endroits éloignés de la zone de travail, on augmente le risque de voir passer le courant de soudage par les chaînes de levage, câbles de grue, ou autres circuits. Cela peut provoquer des risques d'incendie ou d'échauffement des chaînes et des câbles jusqu'à ce qu'ils se rompent.
9. Assurer une ventilation suffisante dans la zone de soudage. Ceci est particulièrement important pour le soudage de tôles galvanisées plombées, ou cadmiées ou tout autre métal qui produit des fumeés toxiques.
10. Ne pas souder en présence de vapeurs de chlore provenant d'opérations de dégraissage, nettoyage ou pistolage. La chaleur ou les rayons de l'arc peuvent réagir avec les vapeurs du solvant pour produire du phosgène (gas fortement toxique) ou autres produits irritants.
11. Pour obtenir de plus amples renseignements sur la sûreté, voir le code "Code for safety in welding and cutting" CSA Standard W 117.2-1974.

PRÉCAUTIONS DE SÛRETÉ POUR LES MACHINES À SOUDER À TRANSFORMATEUR ET À REDRESSEUR

1. Relier à la terre le chassis du poste conformément au code de l'électricité et aux recommandations du fabricant. Le dispositif de montage ou la pièce à souder doit être branché à une bonne mise à la terre.
2. Autant que possible, l'installation et l'entretien du poste seront effectués par un électricien qualifié.
3. Avant de faire des travaux à l'intérieur de poste, la débrancher à l'interrupteur à la boîte de fusibles.
4. Garder tous les couvercles et dispositifs de sûreté à leur place.

Thank You

for selecting a **QUALITY** product by Lincoln Electric. We want you to take pride in operating this Lincoln Electric Company product
••• as much pride as we have in bringing this product to you!

Please Examine Carton and Equipment For Damage Immediately

When this equipment is shipped, title passes to the purchaser upon receipt by the carrier. Consequently, Claims for material damaged in shipment must be made by the purchaser against the transportation company at the time the shipment is received.

Please record your equipment identification information below for future reference. This information can be found on your machine nameplate.

Product _____

Model Number _____

Code Number or Date Code _____

Serial Number _____

Date Purchased _____

Where Purchased _____

Whenever you request replacement parts or information on this equipment, always supply the information you have recorded above. The code number is especially important when identifying the correct replacement parts.

On-Line Product Registration

- Register your machine with Lincoln Electric either via fax or over the Internet.
- For faxing: Complete the form on the back of the warranty statement included in the literature packet accompanying this machine and fax the form per the instructions printed on it.
- For On-Line Registration: Go to our **WEB SITE at www.lincolnelectric.com**. Choose "Quick Links" and then "Product Registration". Please complete the form and submit your registration.

Read this Operators Manual completely before attempting to use this equipment. Save this manual and keep it handy for quick reference. Pay particular attention to the safety instructions we have provided for your protection. The level of seriousness to be applied to each is explained below:

⚠ WARNING

This statement appears where the information **must** be followed **exactly** to avoid **serious personal injury or loss of life**.

⚠ CAUTION

This statement appears where the information **must** be followed to avoid **minor personal injury or damage to this equipment**.

INSTALLATION SECTION	A
Technical Specifications	A-1
Safety Precautions	A-2
Power Source Connections	A-2
Gun Cable Connection to Feeder	A-3
Weld Cable Connection.....	A-4
Electrode Cable Connection	A-4
Work Cable Connection	A-4
Drive Roll Installation	A-4
<hr/>	
OPERATION	SECTION B
Safety Precautions	B-1
General Description.....	B-1
Recommended Processes and Equipment	B-1
Welding Capability	B-1
LN-35 Instruments and Controls	B-1
Work Clip Lead	B-2
Wire reel Loading-50 and 60 LB.	B-2
Loading Wire Drive	B-3
Idle Roll Pressure Setting	B-3
Presetting Wire Feed Speed	B-4
Making a Weld	B-5
Procedure at End of Coil.....	B-6
Open Arc Welding with a Constant Current	B-6
Automatic Protection Shutdown	B-7
<hr/>	
MAINTENANCE	SECTION D
Safety Precautions.....	D-1
Routine Maintenance	D-1
Circuit Protection and Automatic Shutdown	D-1
Adjusting Speed Sensor Module.....	D-2
Calibration of the LN-35 Wire Speed Dial	D-2
<hr/>	
TROUBLESHOOTING GUIDE	SECTION E
How to Use the Troubleshooting Guide	E-1
Troubleshooting Guide.....	E-2,E-3
<hr/>	
WIRING DIAGRAMS	F-1

TECHNICAL SPECIFICATIONS – LN-35 (K2281-1)

Constant Voltage (CV) or Constant Current (CC)		15-40 VDC (110VDC Maximum OCV)	
Rated current		500 Amps 60% Duty Cycle	
50 – 500 Inches Per Minute (IPM) (1270-12700 mm/Min.)			
7/64 Inches (2.78 mm)		CORED WIRE	
<u>HEIGHT</u>	<u>WIDTH</u>	<u>DEPTH</u>	<u>WEIGHT</u>
27 Inches (686 mm)	14.25 Inches (362 mm)	33 Inches (838 mm)	82 lbs (37 kg)
TEMPERATURE RANGE			
OPERATION:	- 40° C to +40° C (- 40° F to +104° F)		
STORAGE:	- 40° C to +85° C (- 40° F to +185° F)		

SAFETY PRECAUTIONS

**WARNING**

The electrode circuit (including welding wire, wire drive and welding gun) is electrically hot when the welding power source is on. The gun trigger controls wire feed only.

Disconnect or shut off welding power source before making connections or installations to the LN-35.

The LN-35 should be positioned upright on a horizontal surface.

**WARNING**

ELECTRIC SHOCK can kill.

- Do not touch metal portions of the LN-35 clamp when welding power source is on.

POWER SOURCE CONNECTION

The LN-35 can be used with any DC welding power source. A constant voltage power source is recommended; however, the LN-35 can also be used with a constant current power source as long as the open circuit voltage is less than 110V DC.

The power source output will be electrically “hot” at all times when the power source is turned on.

See the power source instruction manual for proper power source connections and setting required.

**WARNING**

ELECTRIC SHOCK can kill.

- Do not operate with covers removed.
- Turn off power source before installing or servicing.
- Do not touch electrically hot parts.
- Turn the input power to the welding power source off at the fuse box before working in the terminal strip.
- Only qualified personnel should install, use or service this equipment.

DC-250

- Connect a jumper from 2 to 4 on the power source terminal strip so the output will be energized when the DC-250 is turned on.
- Connect electrode cable to the “Innershield/GMAW” output terminal of polarity required by electrode. Connect work lead to other “Innershield/GMAW” output terminal.
- Place “Set to CV Electrode Cable Polarity” switch at appropriate position.
- Place power source toggle switch in “Output Control at DC-250” position, unless a Remote Control is connected to 75, 76 and 77 on the DC-250 terminal strip.
- Place mode switch in “Innershield GMAW (CV)” position. Set CV arc control to “2” (or “NORMAL” on some machines). Initially set the output control on “7”.

DC-400 AND CV-400

- Connect a jumper from 2 to 4 on the power source terminal strip so the output will be energized when the power source is turned on.

NOTE: DC-400 machines above Code 9200 have an output toggle switch to perform this function.

- Connect the electrode cable to the output terminal of polarity required by electrode. Connect work lead to other output terminal.

LN-35

- c. Place “Set to Same Polarity As Electrode Cable Connection” switch at appropriate position.
- d. Place power source toggle switch in “Output Control at DC(CV) -400” position, unless a remote control is connected to 75, 76 and 77 on the power source terminal strip.
- e. If power source has a mode switch, set switch to Constant Voltage Innershield. Initially set the output control on “6”.

DC-600

- a. Connect a jumper from 2 to 4 on the power source terminal strip so the output will be energized when the DC-600 is turned on. (For DC-600 below Code 8200, also jumper N to S.)
- b. Connect the electrode cable to the output terminal of polarity required by electrode. Connect work lead to other output terminal.
- c. Place “Set to Same Polarity As Electrode Cable Connection” switch at appropriate position.
- d. Place power source toggle switch in “Output Control at DC-600” position, unless a remote control is connected to 75, 76 and 77 on the DC-600 terminal strip.
- e. Set mode switch to Constant Voltage Innershield. Initially set output control on “4”.

R3S-325

- a. Connect a jumper from 4 to 32 on the power source terminal strip so that the output will be energized when the R3S-325 is turned on.
- b. Connect the electrode cable to the output terminal of polarity required by electrode. Connect work lead to other output terminal.
- c. Set power source per its instruction manual.

NOTE: Use of the optional Line Voltage Compensator available for the R3S-325 is recommended if input line voltage variation exceeds $\pm 3\%$.

SAM-400, —650

- a. Connect a jumper from 2 to C4 on the power source terminal strip so the output will be energized when the SAM power source is on.
- b. Connect work lead to WORK stud. Connect electrode to AUTO EQUIPMENT stud. Connect SAM-650 “Tap” lead to the Innershield stud desired.

- c. Set ELECTRODE POLARITY switch to constant voltage polarity required by electrode.
- d. Set toggle switch to “Constant Voltage” and set the Constant Voltage Control on welder and the portable field control on #5 for initial start.

SA-200, —250 OR SAE-300, —400 (WITH CV ADAPTER)

- a. For electrode negative welding, connect the electrode lead from the LN-35 to the output terminal on the CV Adapter, and the work lead to the power source output terminal labeled “POSITIVE”. For electrode positive welding, interchange the above lead connections so the LN-35 electrode lead is then connected to the positive power source terminal.
- b. Place both switches on the CV Adapter to the CV INNERSHIELD position and make appropriate power source settings per the CV Adapter instructions provided for the power source being used.
- c. The output voltage is set with the voltage control on the CV Adapter.

NOTE: Refer to the Instruction Manual provided with the machine for details on connection and operation of the LN-35 with the power source.

INVERTEC, CV300 AND OTHER NEWER LINCOLN POWER SOURCES

Refer to the instruction manual provided with the power source for details on connection and operation of the LN-35 with these newer machines.

GUN CABLE CONNECTION TO FEEDER

Lay the cable out straight. Insert the connector on the welding conductor cable into the brass conductor block on the front of the wire drive unit. Make sure it is all the way in and tighten the hand wheel clamp. Keep this connection clean and bright. Connect the control cable polarized amphenol plug into the mating 5-cavity receptacle on the front panel of the wire feeder case.

WELD CABLE CONNECTION

The size of the electrode cable and work cable must be sufficient for the maximum weld current and total cable length to be used. Refer to table A.1.

TABLE A.1

Weld Current 60% Duty Cycle	Total Cable Length			
	50'-100'	100'-150'	150'-200'	200'-250'
200Amps	2 AWG	2 AWG	1 AWG	1/0
300Amps	1 AWG	1 AWG	1/0	2/0
400Amps	2/0	2/0	3/0	3/0
500Amps	2/0	3/0	3/0	4/0

ELECTRODE CABLE CONNECTION

Route the electrode cable through the oval hole in the LN-35 rear panel. Connect the electrode cable to the LN-35 using the 1/2" bolt on the front of the wire drive.

WORK CABLE CONNECTION

Connect a work lead of sufficient size between the proper output stud on the power source and the work. Be sure the connection to the work makes tight metal-to-metal electrical contact. Poor work lead connections can result in poor welding performance.

DRIVE ROLL INSTALLATION

CHANGING DRIVE ROLLS FOR TWO-ROLL WIRE FEEDERS:

To change drive rolls on a two-roll wire feeder, refer to Figure A.1 and perform the following steps:

1. Rotate the latch knob on the quick release arm.
2. Remove the hex head screw and clamping collar. Remove the drive roll from the shaft.
3. The new roll to be installed is stamped for the size to be fed. An "A" after the size indicates aluminum wire. Remove the rolls from the kit and wipe them clean. Wipe the output shaft and locating shoulder clean.
4. Use the drive key, clamping collar, and hex head screw to install the roll on the output shaft. Certain size drive rolls consist of two roll halves, and may contain a spacer. If the drive roll you are installing contains a spacer, the spacer fits between the two halves of the drive roll. Tighten the hex head screw.
5. Back out the guide tube clamping screws. Remove the old guide tubes, if installed.
6. Insert the outgoing guide tube (the one with the plastic insert) into the front hole. If the guide tube has a non-symmetrical chisel end, the larger radius must face the drive roll. See Figure A.1. Push the guide tube back as far as it will go and tighten the clamping screw. Insert the incoming guide tube as far back as it will go and tighten the clamping screw. The clamping screws are dog points. When the guide tubes are properly installed these dog points will lock into the annular grooves in each of the guide tubes.
7. Set the idle roll pressure as detailed in the Idle Roll Pressure Setting procedure detailed later in this section.

FIGURE A.1 – INSTALLING DRIVE ROLLS ON A TWO-ROLL FEEDER.

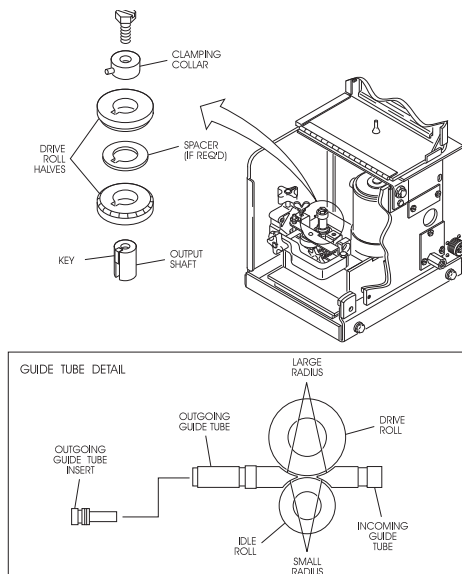

LN-35

LINCOLN
ELECTRIC

SAFETY PRECAUTIONS

READ AND UNDERSTAND ENTIRE SECTION BEFORE OPERATING MACHINE



WARNING

ELECTRIC SHOCK can kill.



- Do not touch electrically live part or electrode with skin or wet clothing.
- Insulate yourself from work and ground.
- Always wear dry insulating gloves.



FUMES AND GASSES can be dangerous.

- Keep your head out of fumes.
- Use ventilation or exhaust to remove fumes from breathing zone.



WELDING SPARKS can cause fire or explosion.

- Keep flammable material away.

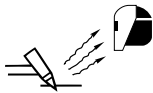

ARC RAYS can burn.

- Wear eye, ear and body protection.

GENERAL DESCRIPTION

The LN-35 is a semiautomatic wire feeder designed for “across-the-arc” operation without a control cable on most any DC welding power source. Simply connect the LN-35 to the electrode cable, clip it to Work and it is ready to weld, using up to 60 lb. coils or spools.

RECOMMENDED PROCESSES AND EQUIPMENT

When combined with the quality drive roll kits and accessories available for use with the LN-35, a versatile welding system can be provided to meet the specific needs of Innershield or submerged arc welding applications within the wire feed capabilities of the LN-35.

The LN-35 provides constant wire feed speed for use with constant voltage (CV) power sources, and arc-sensing wire feed speed for use with constant current (CC) (formerly variable voltage) power sources. Wire speed is presettable on a calibrated dial.

The power sources recommended for use with the LN-35 include the DC-250, -400, -600, CV-400 and R3S type transformer machines, and the SAM-400, -650 engine welders, as well as the SA-200, -250 or SAE-300, -400 with CV Adapter.

WELDING CAPABILITY

The LN-35 will handle up to 500 Amp 60% duty cycle welding currents.

LN-35 INSTRUMENTS AND CONTROLS

“ELECTRODE POLARITY” SWITCH

The polarity switch is located on the center panel inside the LN-35 case.

Set the switch to the same polarity as the electrode lead connection to the power source. If the switch is not set for the correct polarity, the wire feeder will not operate.

WIRE FEED MODE SWITCH

The CV-VV (CC) Wire Feed Mode switch is located on the center panel inside the LN-35 case.

The forward “CV” switch position provides constant wire feed speed mode for use with constant voltage (CV) welding power sources.

The backward “VV (CC)” switch position provides arc-sensing wire feed speed mode for use with constant current (formerly variable voltage) welding power sources.

WIRE FEED SPEED CONTROL

This control sets the feed speed of the wire feeder. Turn the knob to the left for slower speeds and to the right for higher speeds. The control is calibrated. The nameplate shows the wire speed for the given setting of the control.

LN-35

LINCOLN[®]
ELECTRIC

WORK CLIP LEAD

**WARNING****ELECTRIC SHOCK can kill.**

- Do not touch metal portions of the LN-35 lead clip when welding power source is on.

**WARNING**

IMPORTANT SAFETY NOTE: To avoid possible electrical shock, do not touch the metal portions of the LN-35 work lead clamp if the power source output is on. The clamp will be electrically “HOT” to work if the input electrode cable to the LN-35 is electrically “HOT” even if the gun trigger is off. Care should be taken to only handle the LN-35 work clamp by its non-metal insulated portions and/or the welding power source should be turned off before handling the work clamp.

The 15 ft work clamp lead attached to the front panel of the LN-35 case must be connected directly to the work using the spring clamp on the end of the lead.

If not connected, the LN-35 will not operate. However, the electrode will still be electrically “HOT” when the clamp lead is disconnected.

WIRE REEL LOADING – 50 AND 60 LB**ADJUSTABLE WIRE REEL BRAKE**

The mount for standard 50 and 60 pound electrode coils includes a two-position brake assembly. Generally the brake should be at the inner position (nearest to the wire reel shaft) for wire feed speeds below 400 in./min (10 m/min). It should be at the outer position for the faster wire speeds often used when feeding smaller diameter electrode.

To adjust the brake position, remove the wire reel. Pull the cotter pin that holds the brake shoe to the arm, move the shoe and replace the cotter pin. Do not bend the cotter pin - it is held in place by a friction fit.

TO MOUNT A 50 OR 60 LB COIL:

1. To remove the wire reel from its shaft.
2. Lay the reel flat on the floor. Loosen the spinner nut and remove the cover plate. See Figure B.1.
3. Place the coil of electrode on the reel so it unwinds as the reel rotates clockwise. **DO NOT** cut the tie wires at this time.
4. Be sure the coil is placed so the spring loaded arms will not interfere with the later removal of the coil tie wires.
5. When loading 0.030, 0.035, and 0.045” electrode, be certain the coil is placed on the reel so the spring loaded arms are at the center of the slots in the cardboard coil liner. This provides the positive compression of the coil sides needed for trouble-free wire feeding.
6. Put the cover plate on the reel so the four arms of the cover plate straddle and are in line with the spring loaded arms of the reel.
7. Tighten the cover as much as possible by hand.

**CAUTION**

DO NOT hammer on the spinner nut arms. Always be sure the free end of the coil is securely held while the tie wires are being cut and until the wire is feeding through the drive rolls. Failure to do this will result in “back lashing” of the coil, which may tangle the wire. A tangled coil will not feed. It must be untangled or discarded.

8. Cut and remove **only** the tie wire holding the free end of the coil. Insert the free end into one of the holes in the cover and secure it by bending it back. Cut and remove the remaining tie wires.
9. Replace the reel on the wire feeder.

FIGURE B.1 – LOADING A 50 OR 60 LB COIL.

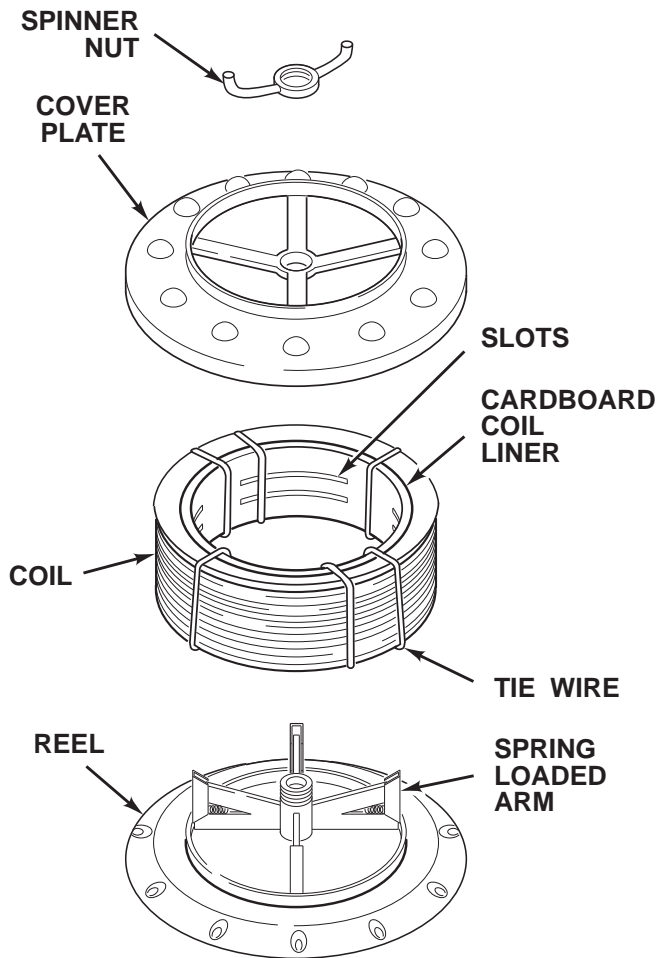

LOADING WIRE DRIVE

- Turn the reel or spool until the free end of the electrode is accessible.
- While tightly holding the electrode, cut off the bent end and straighten the first six inches. Cut off the first inch. (If the electrode is not properly straightened, it may not feed or may not go into the outgoing guide tube causing a “birdnest”.)
- Insert the free end through the incoming guide tube to the drive roll.
- Turn on the welding power source.



WARNING

The electrode circuit is electrically “hot” when the power source is on.

- Press the gun trigger and push the electrode until it **just** enters the drive roll.



WARNING

When inching with gun trigger, the electrode and drive mechanism are always “hot” to work and ground.

- Inch the electrode through the gun.

IDLE ROLL PRESSURE SETTING

The idle roll pressure is set at the factory backed out two turns from full pressure. This is an approximate setting. The optimum idle roll setting can be determined as follows:

- Press end of gun against a solid object that is electrically isolated from the welder output. Press the gun trigger for several seconds.
- If the wire “birdnests,” jams or breaks at the drive roll, the idle roll pressure is too great. Back the pressure setting out $\frac{1}{2}$ turn, run new wire through gun, and repeat above steps.
- If the only result is drive roll slippage, shut off the power source, then loosen the gun cable clamping screw in the gearbox conductor block and pull the gun cable forward about six inches. There should be a slight waviness in the exposed wire. If there is no waviness, the pressure is too low. Increase the pressure setting $\frac{1}{4}$ turn, lock the gun cable in place and repeat the above steps.

PRESETTING WIRE FEED SPEED

The LN-35 permits accurate presetting of the desired wire feed speed, before welding, in both CV and CC wire feed modes.

SETTING CONSTANT WIRE FEED SPEED (CV MODE)

- a. Set Wire Feed Mode switch to CV position.
- b. Set Wire Feed dial to the desired wire feed speed on the selected calibrated dial range.

The wire speed will remain constant at the value set, independent of arc voltage changes, as long as the arc voltage does not drop below the value per the chart below for the max. wire feed speed shown:

Maximum Speed	Minimum Arc Volts
250 IPM	15V
280 IPM	17V
350 IPM	21V

SETTING ARC SENSING WIRE FEED SPEED (VV [CC] MODE)

When using a constant current (formerly variable voltage) power source, welding performance is improved using arc sensing wire feed speed (VV [CC] mode). In this wire feed mode the wire speed increases if arc voltage increases, and decreases if arc voltage decreases, but remains constant at any specific voltage level.

The LN-35 permits accurate VV (CC) mode presetting of the desired wire feed speed, for the desired arc voltage to be used, by setting the Wire Speed dial in the following manner before welding:

- a. Set Wire Feed Mode switch to VV (CC) position.

- b. Referring to the graph shown in Figure B.3:
 1. Select the horizontal line representing the DESIRED IN/MIN. for the welding procedure. (See example arrow line for 375 in/min.)
 2. Select the diagonal line representing the ARC VOLTS to be used for the welding procedure. (See example arrow line for 29 volts.)
 3. Determine the vertical line representing the CC WIRE SPEED SETTING where the above two lines cross. (See example arrow line for 450.)
- c. Set the Wire Speed dial to the value determined in Step (3) above (450 for example used).

The wire will feed at the DESIRED IN/MIN speed when the welding power source is set to the arc voltage to be used for the weld procedure (375 in/min. at 29V for example used).

A chart representation of the VV (CC) wire speed setting graph is shown in Figure B.4, giving the Wire Speed dial setting required for the DESIRED IN/MIN and ARC VOLTS used for the welding procedures:

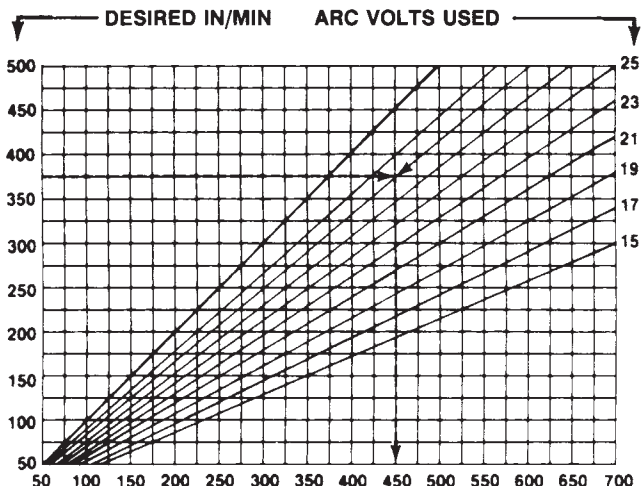

FIGURE B.3 CC WIRE SPEED SETTING

Desired In/Min	Arc Volts Used									
	16	18	20	22	24	26	28	30	32	34
50	109	97	88	80	73	67	63	58	55	51
60	131	117	105	95	88	81	75	70	66	62
70	153	136	123	111	102	94	88	82	77	72
80	175	156	140	127	117	108	100	93	88	82
90	197	175	158	143	131	121	113	105	98	93
100	219	194	175	159	146	135	125	117	109	103
110	241	214	193	175	160	148	138	128	120	113
120	263	233	210	191	175	162	150	140	131	124
130	284	253	228	207	190	175	163	152	142	134
140	306	272	245	223	204	188	175	163	153	144
150	328	292	263	239	219	202	188	175	164	154
160	350	311	280	255	233	215	200	187	175	165
170	372	331	298	270	248	229	213	198	186	175
180	394	350	315	286	263	242	225	210	197	185
190	416	369	333	302	277	256	238	222	208	196
200	438	389	350	318	292	269	250	233	219	206
210	459	408	368	334	306	283	263	245	230	216
220	481	428	385	350	321	296	275	257	241	226
230	503	447	403	366	335	310	288	268	252	237
240	525	467	420	382	350	323	300	280	263	247
250	547	486	438	398	365	337	313	292	273	257
260	569	506	455	414	379	350	325	303	284	268
270	591	525	473	430	394	365	338	315	295	278
280	613	544	490	445	408	377	350	327	306	288
290	634	564	508	461	423	390	363	338	317	299
300	656	583	525	477	438	404	375	350	328	309
310	678	603	543	493	452	417	388	362	339	319
320	700	622	560	509	467	431	400	373	350	329
330		642	578	525	481	444	413	385	361	340
340		661	595	541	496	458	425	397	372	350
350		681	613	557	510	471	438	408	383	360
360		700	630	572	526	484	450	420	394	370
380			666	604	554	512	472	444	416	392
400			700	636	584	538	500	466	438	412
420				668	612	566	526	490	460	432
440				700	642	592	550	514	482	452
460					670	620	576	536	504	472
480					700	646	600	560	526	494
500						674	626	584	546	514

$$VV (CC) \text{ Speed Setting} = \frac{\text{Desired IPM}}{\text{Arc Volts}} \times 35$$

FIGURE B.4 VV(CC) WIRE SPEED SETTING

MAKING A WELD

SETUP

- a. Connect work cable to metal to be welded. Work cable must make good electrical contact to the work. The work must also be grounded as stated in "Arc Welding Safety Precautions."
- b. Check that the LN-35 is properly connected to the power source for the polarity and process to be used, and appropriate power source settings are made for the procedure to be used. (Refer to power source operating and connection instructions.)
- c. Place the LN-35 conveniently near the work area in a location to minimize exposure to weld spatter and to avoid sharp bends in the gun cable.
- d. Connect the LN-35 Clamp Lead to work and set Polarity Switch to same polarity as electrode.
- e. Set WIRE FEED MODE switch to CV or CC, as appropriate for the power source, then set the proper DIAL RANGE and WIRE SPEED dial setting for the proper wire feed speed per the welding procedure:
 - For CV:** Set dial to the calibrated IN/MIN desired. (Refer to Setting Constant Wire Feed Speed Section.)
 - For CC:** Set dial to value determined from the CC Wire Speed Graph for the DESIRED IN/ MIN and ARC VOLTS to be used. (Refer to Setting Arc Sensing Wire Feed Speed Section.)
- NOTE:** If procedure permits a range of acceptable arc voltage, use the middle of the range to determine proper WIRE SPEED setting.
- f. Be sure the proper contact tip for the wire size being used is in the gun, and the gun is safe from work contact.
- g. Turn on the welding power source.

 **WARNING**

The electrode is electrically "hot" when the power source is on. The gun trigger controls wire feed only.



WARNING

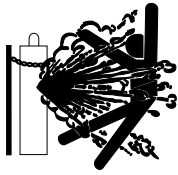

CYLINDER may explode if damaged.

- Keep cylinder upright and chained to support.
- Keep cylinder away from areas where it may be damaged.
- Never lift welder with cylinder attached
- Never allow welding electrode to touch cylinder.
- Keep cylinder away from welding or other live electrical circuits.



WARNING

ARC RAYS can burn.

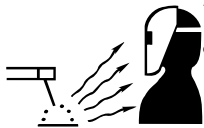

- Do not touch metal portions of the LN-35 lead Clamp when welding power source is on.

- a. Cut the electrode within approximately 3/8" (9.5mm) of the end of the contact tip for solid wire and within approximately 3/4" (19.1mm) of the extension guide for cored wire.
- b. Position electrode over joint. End of electrode should be slightly off the work.
- c. Lower welding helmet, close gun trigger, and begin welding. Hold the gun so the contact tip to work distance gives the correct electrical stickout as required for the procedure being used.

NOTE: If the arc voltage is not within the proper procedure range adjust the power source output control. (The CC mode WIRE SPEED setting should not be changed from the preset procedure value for the proper arc voltage.)

- d. To stop welding, release the gun trigger and then pull the gun away from the work.

PROCEDURE AT END OF COIL

When the wire on the reel is used up, the following procedure is to be followed for removing the old wire from the gun cable and loading a new reel.

- a. Shut off power source if a Remote Output Control Option or internal contactor is not used.
- b. Cut the end of the electrode off at the gun end. Do not break it off by hand since this puts a slight bend in the wire and makes it difficult or impossible to pull it back through the nozzle.
- c. Uncouple the gun conductor cable from the LN-35.
- d. Lay the cable out straight.
- e. Using pliers to grip the wire, pull it out of the cable from the connector end. Do not pull it from the gun end.
- f. Put the conductor cable back on wire drive unit after the electrode has been removed.
- g. Load a new coil of wire and feed it through the cable as described in Loading Electrode Section.

OPEN ARC WELDING WITH A CONSTANT CURRENT (formerly variable voltage) POWER SOURCE

Although a constant voltage (CV) power source is recommended for Innershield® and gas metal arc welding (GMAW), satisfactory general purpose welding may be obtained using the LN-35 with a constant current (CC) power source for non-critical commercial quality mild steel welding applications.

While welding with a continuously fed electrode, weld current variations are continuously taking place. There are many causes for these variations, but predominantly they occur due to changes in electrical stickout (operator hand movements, nozzle tip contact variations, etc.) and the dynamic metal transfer characteristics of the process or procedure being used (short arc, globular transfer, etc.).

When using a CV power source, these current variations have essentially no effect on the welding arc stability since CV power sources can provide a wide range of weld current levels with virtually no change in average arc voltage. These "flat slope" CV power sources, therefore, provide the arc power required to produce the best welding characteristics and ease of operation for most open arc, constant wire feed speed, welding processes.

CC (formerly VV) power sources, on the other hand, permit the arc voltage to decrease with increases in welding current. The output characteristics of these power sources can range from a “drooping slope,” which provide minor arc voltage changes with weld current variations, to “steep slope” which provide broad voltage changes with only minor current variations. The steeper the slope the more difficult it becomes to maintain arc voltage stability with a constant wire speed open arc process.

To aid in stabilizing the arc voltage when welding on CC power sources the LN-35 is provided with a VV (CC) wire feed mode. This arc voltage sensing feed mode decreases (or increases) the wire speed when the arc voltage decreases (or increases). **However**, if the electrode shorts to the work, the arc voltage will essentially drop to zero and the short circuit current supplied by the CC power source may not provide enough power to re-establish the arc (especially with steeper slope machines). Under this condition the LN-35 feeder will stop, as if the trigger was released, and not restart until the short has been opened.

Arc shorting is more difficult to avoid when using a CC power source, and requires a more refined operator technique than when using a CV power source. Improved performance can be obtained on CC power source applications within the following guidelines:

1. Flatter slope power sources with higher arc force (short circuit current) will improve performance over steep slope machines. The steeper the slope, the more critical it is to hold proper electrode stickout to maintain arc stability. Welding techniques, such as weaving, will be more difficult to control. Use the highest output current tap or setting capable of providing the voltage adjustment required for the procedure.

AUTOMATIC PROTECTION SHUTDOWN

The LN-35 control provides automatic electronic protection circuits which shut down the LN-35 for excessively high power source open circuit voltage or excessive motor overload.

OVERVOLTAGE SHUTDOWN

If the power source open circuit voltage exceeds about 110-120 volts, the LN-35 will not operate until the power source voltage drops below about 102-110 volts.

MOTOR OVERLOAD SHUTDOWN

If excessive motor overload occurs (due to prolonged excessive feeding force, jammed drive rolls or shorted motor leads), the LN-35 will shut down within a few seconds after the overload occurs.

The shutdown will reset automatically when the gun trigger is released, but will reoccur if the overload situation is not remedied.

SAFETY PRECAUTIONS

WARNING

Have qualified personnel do the maintenance work. Turn the engine off before working inside the machine. In some cases, it may be necessary to remove safety guards to perform required maintenance. Remove guards only when necessary and replace them when the maintenance requiring their removal is complete. Always use the greatest care when working near moving parts.

Do not put your hands near the engine cooling blower fan. If a problem cannot be corrected by following the instructions, take the machine to the nearest Lincoln Field Service Shop.



ELECTRIC SHOCK can kill.

- Do not operate with covers removed.
- Do not touch electrically live parts or electrode with skin or wet clothing.
- Turn the input power to the welding power source off at the fuse box before working in the terminal strip.
- Insulate yourself from work and ground
- Always wear dry insulating gloves.

See additional warning information throughout this operator's manual and the Engine manual as well.

ROUTINE MAINTENANCE

DRIVE ROLLS AND GUIDE TUBES

After feeding every coil of wire, inspect the drive roll section. Clean it as necessary. Do not use a solvent for cleaning the idle roll because it may wash the lubricant out of the bearing. The drive roll, idle roll and guide tubes are stamped with the wire sizes they will feed. If a wire size other than that stamped on the rolls is to be used, the rolls and guide tubes must be changed.

The drive rolls for .035 through .052 cored electrode and 1/16 through 5/64 electrode have a double set of teeth so they can be reversed for additional life. Drive rolls for .023 through .052 solid electrode and aluminum sizes have no teeth but use two grooves so they also can be reversed for additional life.

See Wire Feed Drive Roll and Guide Tube Kits Section for roll changing instructions.

WIRE REEL SPINDLE

No routine maintenance required. Do not lubricate spindle.

CONTROL BOX

Every six months open and inspect the control section. The accumulated dirt should be gently blown off all of the electrical components. Be sure the air that is being used is dry. Check that lead plugs are secure in their receptacles.

WIRE DRIVE MOTOR AND GEAR BOX

Every year examine the gear box. Paint the gear teeth with molydisulfide filled grease. Lincoln specification E2322. **Do not** use a graphite grease.

Check the motor brushes. Replace if they are worn down to 1/4 inch or less. When ordering feed motor brushes, give all information from the motor nameplate.

GUN AND CABLE MAINTENANCE

See IM manual provided with the gun and cable assembly.

CIRCUIT PROTECTION AND AUTOMATIC SHUTDOWN

CONTROL PC BOARD FUSE

On G1757-6 (or higher part no.) P.C. Boards the 1/8 amp fuse was replaced with electronic protection for trigger circuit faults to electrode circuit.

On G1757-2 through -5 part no. PC boards, the 1/8 amp fuse interrupts the 500A lead to the trigger switch. On G1757- 1 PC boards a 5 amp fuse was used to interrupt the 667 lead. The LN-35 will not operate if the fuse is blown.

AUTOMATIC PROTECTION SHUTDOWN

(See Automatic Protection Shutdown Section.)

ADJUSTING SPEED SENSOR MODULE

The LN-35 Speed Sensor Module is a three lead Hall Effect switch device encased in an externally threaded housing which is screwed into a mounting plate on the motor side of the wire drive gearbox.

Proper positioning of this module is critical to proper operation of the LN-35 wire feed speed control. If the device is not screwed in far enough, the LN-35 motor speed could be unstable or run at full speed with no control. If screwed in too far, it will rub a moving part inside the gearbox.

The module is properly mounted to the gearbox as shipped from the factory. If the device is ever removed or replaced, proper mounting technique is as follows:

1. Be sure all power to the LN-35 is shut off at the power source.
2. Check that the module mounting plate is screwed securely to the side of the gearbox.
3. Gently screw the module into the mounting plate until it **just** touches and stops against the rotating part inside the gearbox.
4. Back the module out 1/2 turn, then snug the module lock nut without rotating the module position. Do not overtighten lock nut.

CALIBRATION OF LN-35 WIRE SPEED DIAL

Calibration of the LN-35 Wire Speed dial is achieved by proper mounting of the dial knob to the speed potentiometer shaft. Whenever the knob is removed, the dial is recalibrated as follows:

NOTE: Knob set screw does **not** seat on shaft flat.

1. Be sure the Wire Speed potentiometer mounting nut is securely tightened, then rotate the potentiometer shaft so its flat faces about to the 100 mark on the calibrated dial.
2. Set WIRE FEED MODE switch to CV position.
3. Press gun trigger to feed wire and measure the wire feed speed (IN/MIN) using a Portable Digital Wire Feed Speed Meter (Lincoln K283). Take at least two readings to assure repeatable accuracy.

Feed Speed Meter (Lincoln K283). Take at least two readings to assure repeatable accuracy.



WARNING

Electrode will be electrically “hot”. Do not allow fed wire to contact any metal common with welding work.

An alternate means to measure wire feed speed is as follows:

- a. Cut wire off at the end of the gun tip.
 - b. Press trigger to feed wire for exactly 30 seconds.
 - c. Cut fed wire off at the end of the gun tip and accurately measure its length.
 - d. Multiply the measured length by 2 to obtain the wire speed (IN/MIN).
 - e. Repeat above steps to assure repeatable accuracy.
4. Carefully slip speed knob onto potentiometer shaft so it points precisely to the wire speed measured in step 3, then secure the knob set screw without disturbing the position. Recheck by repeating step 3.

LN-35



HOW TO USE TROUBLESHOOTING GUIDE

WARNING

Service and Repair should only be performed by Lincoln Electric Factory Trained Personnel. Unauthorized repairs performed on this equipment may result in danger to the technician and machine operator and will invalidate your factory warranty. For your safety and to avoid Electrical Shock, please observe all safety notes and precautions detailed throughout this manual.

This Troubleshooting Guide is provided to help you locate and repair possible machine malfunctions. Simply follow the three-step procedure listed below.

Step 1. LOCATE PROBLEM (SYMPTOM).

Look under the column labeled “PROBLEM (SYMPTOMS)”. This column describes possible symptoms that the machine may exhibit. Find the listing that best describes the symptom that the machine is exhibiting.

Step 2. POSSIBLE CAUSE.

The second column labeled “POSSIBLE CAUSE” lists the obvious external possibilities that may contribute to the machine symptom.

Step 3. RECOMMENDED COURSE OF ACTION

This column provides a course of action for the Possible Cause, generally it states to contact your local Lincoln Authorized Field Service Facility.

If you do not understand or are unable to perform the Recommended Course of Action safely, contact your local Lincoln Authorized Field Service Facility.

CAUTION

If for any reason you do not understand the test procedures or are unable to perform the tests/repairs safely, contact your **Local Lincoln Authorized Field Service Facility** for technical troubleshooting assistance before you proceed.

Observe all Safety Guidelines detailed throughout this manual

PROBLEMS (SYMPTOMS)	POSSIBLE AREAS OF MISADJUSTMENTS	RECOMMENDED COURSE OF ACTION
No wire feed when gun trigger is pulled.	<ol style="list-style-type: none"> 1. Power source must be on and open circuit voltage (OCV) present at weld terminals. 2. LN-35 work clamp may not be connected. 3. LN-35 polarity switch must match electrode polarity. 4. Jumper plug on control or option board may be loose or missing. 5. The power source O.C.V. must be above 15 VDC. But not more than 110 VDC. 6. The gun trigger may be faulty.- Replace gun. 	<p>If all recommended possible areas of misadjustment have been checked and the problem persists, Contact your local Lincoln Authorized Field Service Facility.</p>
Wire feeds for a short time but stops feeding. When gun trigger is released and retriggered wire feeding starts but stops again.	<ol style="list-style-type: none"> 1. The drive motor may be overloaded. Check the wire feeding system. EX. Drive roll tension, reel brake and gun cable liner. 	
Wire feeds OK, but stubs or stops while welding.	<ol style="list-style-type: none"> 1. If the power source is a constant current type supply the arc voltage may be "dipping" below 15 VDC causing the LN-35 to stop or hesitate. 2. Connect a constant voltage type power supply to the LN-35. 3. Make sure wire-feed mode switch (S3) is in the proper position. 	
Rough wire feeding or wire not feeding but drive rolls turning.	<ol style="list-style-type: none"> 1. Gun cable kinked and/or twisted. 2. Wire jammed in gun and cable. 3. Incorrect size or installation of drive roll and guide tubes. 4. Drive roll loose. 5. Gun cable dirty. 6. Worn drive roll. 7. Electrode rusty and/or dirty. 8. Worn nozzle or cable liner. 9. Partially flashed or melted contact tip. 10. Incorrect idle roll pressure. 11. Wire reel brake tension set too high. 	

 **CAUTION**

If for any reason you do not understand the test procedures or are unable to perform the tests/repairs safely, contact your **Local Lincoln Authorized Field Service Facility** for technical troubleshooting assistance before you proceed.

Observe all Safety Guidelines detailed throughout this manual

PROBLEMS (SYMPTOMS)	POSSIBLE AREAS OF MISADJUSTMENTS(S)	RECOMMENDED COURSE OF ACTION
Variable or "hunting" arc.	<ol style="list-style-type: none"> 1. Worn and/or melted contact tip - Replace. 2. Worn work cable or poor work connection. 3. Loose electrode connections. - Check for loose or faulty connections. 4. Wrong electrode polarity for process being used. 	<p>If all recommended possible areas of misadjustment have been checked and the problem persists, Contact your local Lincoln Authorized Field Service Facility.</p>
Weld porosity, narrow and ropey bead, or electrode stubbing into plate when welding.	<ol style="list-style-type: none"> 1. Contaminated weld joint or improper procedures. -Clean joint and check procedure (wire speed and all voltage). 	
Motor feeds but there is no wire feed speed control.	<ol style="list-style-type: none"> 1. Make sure all molex plugs and leads are securely connected to the control board. 2. Check speed sensor - see maintenance section. 	

 **CAUTION**

If for any reason you do not understand the test procedures or are unable to perform the tests/repairs safely, contact your **Local Lincoln Authorized Field Service Facility** for technical troubleshooting assistance before you proceed.

NOTES

LN-35



WARNING	<ul style="list-style-type: none"> ● Do not touch electrically live parts or electrode with skin or wet clothing. ● Insulate yourself from work and ground. 	<ul style="list-style-type: none"> ● Keep flammable materials away. 	<ul style="list-style-type: none"> ● Wear eye, ear and body protection.
Spanish AVISO DE PRECAUCION	<ul style="list-style-type: none"> ● No toque las partes o los electrodos bajo carga con la piel o ropa mojada. ● Aíslese del trabajo y de la tierra. 	<ul style="list-style-type: none"> ● Mantenga el material combustible fuera del área de trabajo. 	<ul style="list-style-type: none"> ● Protéjase los ojos, los oídos y el cuerpo.
French ATTENTION	<ul style="list-style-type: none"> ● Ne laissez ni la peau ni des vêtements mouillés entrer en contact avec des pièces sous tension. ● Isolez-vous du travail et de la terre. 	<ul style="list-style-type: none"> ● Gardez à l'écart de tout matériel inflammable. 	<ul style="list-style-type: none"> ● Protégez vos yeux, vos oreilles et votre corps.
German WARNUNG	<ul style="list-style-type: none"> ● Berühren Sie keine stromführenden Teile oder Elektroden mit Ihrem Körper oder feuchter Kleidung! ● Isolieren Sie sich von den Elektroden und dem Erdboden! 	<ul style="list-style-type: none"> ● Entfernen Sie brennbares Material! 	<ul style="list-style-type: none"> ● Tragen Sie Augen-, Ohren- und Körperschutz!
Portuguese ATENÇÃO	<ul style="list-style-type: none"> ● Não toque partes elétricas e electrodos com a pele ou roupa molhada. ● Isole-se da peça e terra. 	<ul style="list-style-type: none"> ● Mantenha inflamáveis bem guardados. 	<ul style="list-style-type: none"> ● Use proteção para a vista, ouvido e corpo.
Japanese 注意事項	<ul style="list-style-type: none"> ● 通電中の電気部品、又は溶材にヒフやぬれた布で触れないこと。 ● 施工物やアースから身体が絶縁されている様にして下さい。 	<ul style="list-style-type: none"> ● 燃えやすいものの側での溶接作業は絶対にしてはなりません。 	<ul style="list-style-type: none"> ● 目、耳及び身体に保護具をして下さい。
Chinese 警告	<ul style="list-style-type: none"> ● 皮肤或湿衣物切勿接触带电部件及焊条。 ● 使你自已与地面和工作件绝缘。 	<ul style="list-style-type: none"> ● 把一切易燃物品移离工作场所。 	<ul style="list-style-type: none"> ● 佩戴眼、耳及身体劳动保护用具。
Korean 위험	<ul style="list-style-type: none"> ● 전도체나 용접봉을 젖은 형집 또는 피부로 절대 접촉치 마십시오. ● 모재와 접지를 접촉치 마십시오. 	<ul style="list-style-type: none"> ● 인화성 물질을 접근시키지 마십시오. 	<ul style="list-style-type: none"> ● 눈, 귀와 몸에 보호장구를 착용하십시오.
Arabic تحذير	<ul style="list-style-type: none"> ● لا تلمس الاجزاء التي يسري فيها التيار الكهربائي أو الألكترود بجند الجسم أو بالملابس المبللة بالماء. ● ضع عازلا على جسمك خلال العمل. 	<ul style="list-style-type: none"> ● ضع المواد القابلة للاشتعال في مكان بعيد. 	<ul style="list-style-type: none"> ● ضع أدوات وملابس واقية على عينيك وأذنيك وجسمك.

READ AND UNDERSTAND THE MANUFACTURER'S INSTRUCTION FOR THIS EQUIPMENT AND THE CONSUMABLES TO BE USED AND FOLLOW YOUR EMPLOYER'S SAFETY PRACTICES.

SE RECOMIENDA LEER Y ENTENDER LAS INSTRUCCIONES DEL FABRICANTE PARA EL USO DE ESTE EQUIPO Y LOS CONSUMIBLES QUE VA A UTILIZAR, SIGA LAS MEDIDAS DE SEGURIDAD DE SU SUPERVISOR.

LISEZ ET COMPRENEZ LES INSTRUCTIONS DU FABRICANT EN CE QUI REGARDE CET EQUIPMENT ET LES PRODUITS A ETRE EMPLOYES ET SUIVEZ LES PROCEDURES DE SECURITE DE VOTRE EMPLOYEUR.

LESEN SIE UND BEFOLGEN SIE DIE BETRIEBSANLEITUNG DER ANLAGE UND DEN ELEKTRODENEINSATZ DES HERSTELLERS. DIE UNFALLVERHÜTUNGSVORSCHRIFTEN DES ARBEITGEBERS SIND EBENFALLS ZU BEACHTEN.

			
<ul style="list-style-type: none"> ● Keep your head out of fumes. ● Use ventilation or exhaust to remove fumes from breathing zone. 	<ul style="list-style-type: none"> ● Turn power off before servicing. 	<ul style="list-style-type: none"> ● Do not operate with panel open or guards off. 	WARNING
<ul style="list-style-type: none"> ● Los humos fuera de la zona de respiración. ● Mantenga la cabeza fuera de los humos. Utilice ventilación o aspiración para gases. 	<ul style="list-style-type: none"> ● Desconectar el cable de alimentación de poder de la máquina antes de iniciar cualquier servicio. 	<ul style="list-style-type: none"> ● No operar con panel abierto o guardas quitadas. 	Spanish AVISO DE PRECAUCION
<ul style="list-style-type: none"> ● Gardez la tête à l'écart des fumées. ● Utilisez un ventilateur ou un aspirateur pour ôter les fumées des zones de travail. 	<ul style="list-style-type: none"> ● Débranchez le courant avant l'entretien. 	<ul style="list-style-type: none"> ● N'opérez pas avec les panneaux ouverts ou avec les dispositifs de protection enlevés. 	French ATTENTION
<ul style="list-style-type: none"> ● Vermeiden Sie das Einatmen von Schweißrauch! ● Sorgen Sie für gute Be- und Entlüftung des Arbeitsplatzes! 	<ul style="list-style-type: none"> ● Strom vor Wartungsarbeiten abschalten! (Netzstrom völlig öffnen; Maschine anhalten!) 	<ul style="list-style-type: none"> ● Anlage nie ohne Schutzgehäuse oder Innenschutzverkleidung in Betrieb setzen! 	German WARNUNG
<ul style="list-style-type: none"> ● Mantenha seu rosto da fumaça. ● Use ventilação e exaustão para remover fumo da zona respiratória. 	<ul style="list-style-type: none"> ● Não opere com as tampas removidas. ● Desligue a corrente antes de fazer serviço. ● Não toque as partes elétricas nuas. 	<ul style="list-style-type: none"> ● Mantenha-se afastado das partes moventes. ● Não opere com os painéis abertos ou guardas removidas. 	Portuguese ATENÇÃO
<ul style="list-style-type: none"> ● ヒュームから頭を離すようにして下さい。 ● 換気や排煙に十分留意して下さい。 	<ul style="list-style-type: none"> ● メンテナンス・サービスに取りかかる際には、まず電源スイッチを必ず切ってください。 	<ul style="list-style-type: none"> ● パネルやカバーを取り外したまま機械操作をしないで下さい。 	Japanese 注意事項
<ul style="list-style-type: none"> ● 頭部遠離煙霧。 ● 在呼吸區使用通風或排風器除煙。 	<ul style="list-style-type: none"> ● 維修前切斷電源。 	<ul style="list-style-type: none"> ● 儀表板打開或沒有安全罩時不準作業。 	Chinese 警告
<ul style="list-style-type: none"> ● 얼굴로부터 용접가스를 멀리하십시오. ● 호흡지역으로부터 용접가스를 제거하기 위해 가스제거기나 통풍기를 사용하십시오. 	<ul style="list-style-type: none"> ● 보수전에 전원을 차단하십시오. 	<ul style="list-style-type: none"> ● 판넬이 열린 상태로 작동치 마십시오. 	Korean 위험
<ul style="list-style-type: none"> ● ابعِد رأسك بعيداً عن الدخان. ● استعمل التهوية أو جهاز ضغط الدخان للخارج لكي تبعد الدخان عن المنطقة التي تتنفس فيها. 	<ul style="list-style-type: none"> ● اقطع التيار الكهربائي قبل القيام بأية صيانة. 	<ul style="list-style-type: none"> ● لا تشغيل هذا الجهاز اذا كانت الاغطية الحديدية الواقية ليست عليه. 	Arabic تحذير

LEIA E COMPREENDA AS INSTRUÇÕES DO FABRICANTE PARA ESTE EQUIPAMENTO E AS PARTES DE USO, E SIGA AS PRÁTICAS DE SEGURANÇA DO EMPREGADOR.

使う機械や溶材のメーカーの指示書をよく読み、まず理解して下さい。そして貴社の安全規定に従って下さい。

請詳細閱讀並理解製造廠提供的說明以及應該使用的銀焊材料，並請遵守貴方的有閣勞動保護規定。

이 제품에 동봉된 작업지침서를 숙지하시고 귀사의 작업자 안전수칙을 준수하시기 바랍니다.

اقرأ بتمعن وافهم تعليمات المصنع المنتج لهذه المعدات والمواد قبل استعمالها واتبع تعليمات الوقاية لصاحب العمل.



• World's Leader in Welding and Cutting Products •

• Sales and Service through Subsidiaries and Distributors Worldwide •

Cleveland, Ohio 44117-1199 U.S.A. TEL: 216.481.8100 FAX: 216.486.1751 WEB SITE: www.lincolnelectric.com