

For use with machine Code Numbers above: **9535**

Safety Depends on You

Lincoln arc welding and cutting equipment is designed and built with safety in mind. However, your overall safety can be increased by proper installation ... and thoughtful operation on your part. DO NOT INSTALL, OPERATE OR REPAIR THIS EQUIPMENT WITHOUT READING THIS MANUAL AND THE SAFETY PRECAUTIONS CONTAINED THROUGHOUT. And, most importantly, think before you act and be careful.



OPERATOR'S MANUAL



Copyright © Lincoln Global Inc.

- World's Leader in Welding and Cutting Products •
- Sales and Service through Subsidiaries and Distributors Worldwide •

Cleveland, Ohio 44117-1199 U.S.A. TEL: 216.481.8100 FAX: 216.486.1751 WEB SITE: www.lincolnelectric.com

⚠ WARNING

⚠ CALIFORNIA PROPOSITION 65 WARNINGS ⚠

Diesel engine exhaust and some of its constituents are known to the State of California to cause cancer, birth defects, and other reproductive harm.

The Above For Diesel Engines

The engine exhaust from this product contains chemicals known to the State of California to cause cancer, birth defects, or other reproductive harm.

The Above For Gasoline Engines

ARC WELDING CAN BE HAZARDOUS. PROTECT YOURSELF AND OTHERS FROM POSSIBLE SERIOUS INJURY OR DEATH. KEEP CHILDREN AWAY. PACEMAKER WEARERS SHOULD CONSULT WITH THEIR DOCTOR BEFORE OPERATING.

Read and understand the following safety highlights. For additional safety information, it is strongly recommended that you purchase a copy of "Safety in Welding & Cutting - ANSI Standard Z49.1" from the American Welding Society, P.O. Box 351040, Miami, Florida 33135 or CSA Standard W117.2-1974. A Free copy of "Arc Welding Safety" booklet E205 is available from the Lincoln Electric Company, 22801 St. Clair Avenue, Cleveland, Ohio 44117-1199.

BE SURE THAT ALL INSTALLATION, OPERATION, MAINTENANCE AND REPAIR PROCEDURES ARE PERFORMED ONLY BY QUALIFIED INDIVIDUALS.



FOR ENGINE powered equipment.

1.a. Turn the engine off before troubleshooting and maintenance work unless the maintenance work requires it to be running.



1.b. Operate engines in open, well-ventilated areas or vent the engine exhaust fumes outdoors.



1.c. Do not add the fuel near an open flame welding arc or when the engine is running. Stop the engine and allow it to cool before refueling to prevent spilled fuel from vaporizing on contact with hot engine parts and igniting. Do not spill fuel when filling tank. If fuel is spilled, wipe it up and do not start engine until fumes have been eliminated.



1.d. Keep all equipment safety guards, covers and devices in position and in good repair. Keep hands, hair, clothing and tools away from V-belts, gears, fans and all other moving parts when starting, operating or repairing equipment.

1.e. In some cases it may be necessary to remove safety guards to perform required maintenance. Remove guards only when necessary and replace them when the maintenance requiring their removal is complete. Always use the greatest care when working near moving parts.

1.f. Do not put your hands near the engine fan. Do not attempt to override the governor or idler by pushing on the throttle control rods while the engine is running.

1.g. To prevent accidentally starting gasoline engines while turning the engine or welding generator during maintenance work, disconnect the spark plug wires, distributor cap or magneto wire as appropriate.



1.h. To avoid scalding, do not remove the radiator pressure cap when the engine is hot.



ELECTRIC AND MAGNETIC FIELDS may be dangerous

2.a. Electric current flowing through any conductor causes localized Electric and Magnetic Fields (EMF). Welding current creates EMF fields around welding cables and welding machines

2.b. EMF fields may interfere with some pacemakers, and welders having a pacemaker should consult their physician before welding.

2.c. Exposure to EMF fields in welding may have other health effects which are now not known.

2.d. All welders should use the following procedures in order to minimize exposure to EMF fields from the welding circuit:

2.d.1. Route the electrode and work cables together - Secure them with tape when possible.

2.d.2. Never coil the electrode lead around your body.

2.d.3. Do not place your body between the electrode and work cables. If the electrode cable is on your right side, the work cable should also be on your right side.

2.d.4. Connect the work cable to the workpiece as close as possible to the area being welded.

2.d.5. Do not work next to welding power source.

Mar '95



ELECTRIC SHOCK can kill.

3.a. The electrode and work (or ground) circuits are electrically “hot” when the welder is on. Do not touch these “hot” parts with your bare skin or wet clothing. Wear dry, hole-free gloves to insulate hands.

3.b. Insulate yourself from work and ground using dry insulation. Make certain the insulation is large enough to cover your full area of physical contact with work and ground.

In addition to the normal safety precautions, if welding must be performed under electrically hazardous conditions (in damp locations or while wearing wet clothing; on metal structures such as floors, gratings or scaffolds; when in cramped positions such as sitting, kneeling or lying, if there is a high risk of unavoidable or accidental contact with the workpiece or ground) use the following equipment:

- Semiautomatic DC Constant Voltage (Wire) Welder.
- DC Manual (Stick) Welder.
- AC Welder with Reduced Voltage Control.

3.c. In semiautomatic or automatic wire welding, the electrode, electrode reel, welding head, nozzle or semiautomatic welding gun are also electrically “hot”.

3.d. Always be sure the work cable makes a good electrical connection with the metal being welded. The connection should be as close as possible to the area being welded.

3.e. Ground the work or metal to be welded to a good electrical (earth) ground.

3.f. Maintain the electrode holder, work clamp, welding cable and welding machine in good, safe operating condition. Replace damaged insulation.

3.g. Never dip the electrode in water for cooling.

3.h. Never simultaneously touch electrically “hot” parts of electrode holders connected to two welders because voltage between the two can be the total of the open circuit voltage of both welders.

3.i. When working above floor level, use a safety belt to protect yourself from a fall should you get a shock.

3.j. Also see Items 6.c. and 8.



ARC RAYS can burn.

4.a. Use a shield with the proper filter and cover plates to protect your eyes from sparks and the rays of the arc when welding or observing open arc welding. Headshield and filter lens should conform to ANSI Z87.1 standards.

4.b. Use suitable clothing made from durable flame-resistant material to protect your skin and that of your helpers from the arc rays.

4.c. Protect other nearby personnel with suitable, non-flammable screening and/or warn them not to watch the arc nor expose themselves to the arc rays or to hot spatter or metal.



FUMES AND GASES can be dangerous.

5.a. Welding may produce fumes and gases hazardous to health. Avoid breathing these fumes and gases. When welding, keep your head out of the fume. Use enough ventilation and/or exhaust at the arc to keep fumes and gases away from the breathing zone. **When welding with electrodes which require special ventilation such as stainless or hard facing (see instructions on container or MSDS) or on lead or cadmium plated steel and other metals or coatings which produce highly toxic fumes, keep exposure as low as possible and within applicable OSHA PEL and ACGIH TLV limits using local exhaust or mechanical ventilation. In confined spaces or in some circumstances, outdoors, a respirator may be required. Additional precautions are also required when welding on galvanized steel.**

5.b. The operation of welding fume control equipment is affected by various factors including proper use and positioning of the equipment, maintenance of the equipment and the specific welding procedure and application involved. Worker exposure level should be checked upon installation and periodically thereafter to be certain it is within applicable OSHA PEL and ACGIH TLV limits.

5.c. Do not weld in locations near chlorinated hydrocarbon vapors coming from degreasing, cleaning or spraying operations. The heat and rays of the arc can react with solvent vapors to form phosgene, a highly toxic gas, and other irritating products.

5.d. Shielding gases used for arc welding can displace air and cause injury or death. Always use enough ventilation, especially in confined areas, to insure breathing air is safe.

5.e. Read and understand the manufacturer’s instructions for this equipment and the consumables to be used, including the material safety data sheet (MSDS) and follow your employer’s safety practices. MSDS forms are available from your welding distributor or from the manufacturer.

5.f. Also see item 1.b.

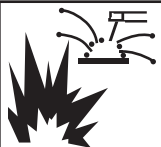

WELDING and CUTTING SPARKS can cause fire or explosion.

6.a. Remove fire hazards from the welding area. If this is not possible, cover them to prevent the welding sparks from starting a fire.

Remember that welding sparks and hot materials from welding can easily go through small cracks and openings to adjacent areas. Avoid welding near hydraulic lines. Have a fire extinguisher readily available.

6.b. Where compressed gases are to be used at the job site, special precautions should be used to prevent hazardous situations. Refer to "Safety in Welding and Cutting" (ANSI Standard Z49.1) and the operating information for the equipment being used.

6.c. When not welding, make certain no part of the electrode circuit is touching the work or ground. Accidental contact can cause overheating and create a fire hazard.

6.d. Do not heat, cut or weld tanks, drums or containers until the proper steps have been taken to insure that such procedures will not cause flammable or toxic vapors from substances inside. They can cause an explosion even though they have been "cleaned." For information, purchase "Recommended Safe Practices for the Preparation for Welding and Cutting of Containers and Piping That Have Held Hazardous Substances," AWS F4.1 from the American Welding Society (see address above).

6.e. Vent hollow castings or containers before heating, cutting or welding. They may explode.

6.f. Sparks and spatter are thrown from the welding arc. Wear oil free protective garments such as leather gloves, heavy shirt, cuffless trousers, high shoes and a cap over your hair. Wear ear plugs when welding out of position or in confined places. Always wear safety glasses with side shields when in a welding area.

6.g. Connect the work cable to the work as close to the welding area as practical. Work cables connected to the building framework or other locations away from the welding area increase the possibility of the welding current passing through lifting chains, crane cables or other alternate circuits. This can create fire hazards or overheat lifting chains or cables until they fail.

6.h. Also see item 1.c.

6.i. Read and follow NFPA 51B "Standard for Fire Prevention During Welding, Cutting and Other Hot Work," available from NFPA, 1 Batterymarch Park, PO box 9101, Quincy, Ma 022690-9101.

6.j. Do not use a welding power source for pipe thawing.



CYLINDER may explode if damaged.

7.a. Use only compressed gas cylinders containing the correct shielding gas for the process used and properly operating regulators designed for the gas and pressure used. All hoses, fittings, etc. should be suitable for the application and maintained in good condition.

7.b. Always keep cylinders in an upright position securely chained to an undercarriage or fixed support.

7.c. Cylinders should be located:

- Away from areas where they may be struck or subjected to physical damage.
- A safe distance from arc welding or cutting operations and any other source of heat, sparks, or flame.

7.d. Never allow the electrode, electrode holder or any other electrically "hot" parts to touch a cylinder.

7.e. Keep your head and face away from the cylinder valve outlet when opening the cylinder valve.

7.f. Valve protection caps should always be in place and hand tight except when the cylinder is in use or connected for use.

7.g. Read and follow the instructions on compressed gas cylinders, associated equipment, and CGA publication P-1, "Precautions for Safe Handling of Compressed Gases in Cylinders," available from the Compressed Gas Association 1235 Jefferson Davis Highway, Arlington, VA 22202.



FOR ELECTRICALLY powered equipment.

8.a. Turn off input power using the disconnect switch at the fuse box before working on the equipment.

8.b. Install equipment in accordance with the U.S. National Electrical Code, all local codes and the manufacturer's recommendations.

8.c. Ground the equipment in accordance with the U.S. National Electrical Code and the manufacturer's recommendations.

Refer to <http://www.lincolnelectric.com/safety> for additional safety information.

PRÉCAUTIONS DE SÛRETÉ

Pour votre propre protection lire et observer toutes les instructions et les précautions de sûreté spécifiques qui paraissent dans ce manuel aussi bien que les précautions de sûreté générales suivantes:

Sûreté Pour Soudage A L'Arc

1. Protégez-vous contre la secousse électrique:
 - a. Les circuits à l'électrode et à la pièce sont sous tension quand la machine à souder est en marche. Eviter toujours tout contact entre les parties sous tension et la peau nue ou les vêtements mouillés. Porter des gants secs et sans trous pour isoler les mains.
 - b. Faire très attention de bien s'isoler de la masse quand on soude dans des endroits humides, ou sur un plancher métallique ou des grilles métalliques, principalement dans les positions assis ou couché pour lesquelles une grande partie du corps peut être en contact avec la masse.
 - c. Maintenir le porte-électrode, la pince de masse, le câble de soudage et la machine à souder en bon et sûr état de fonctionnement.
 - d. Ne jamais plonger le porte-électrode dans l'eau pour le refroidir.
 - e. Ne jamais toucher simultanément les parties sous tension des porte-électrodes connectés à deux machines à souder parce que la tension entre les deux pinces peut être le total de la tension à vide des deux machines.
 - f. Si on utilise la machine à souder comme une source de courant pour soudage semi-automatique, ces précautions pour le porte-électrode s'appliquent aussi au pistolet de soudage.
2. Dans le cas de travail au dessus du niveau du sol, se protéger contre les chutes dans le cas où on recoit un choc. Ne jamais enrouler le câble-électrode autour de n'importe quelle partie du corps.
3. Un coup d'arc peut être plus sévère qu'un coup de soleil, donc:
 - a. Utiliser un bon masque avec un verre filtrant approprié ainsi qu'un verre blanc afin de se protéger les yeux du rayonnement de l'arc et des projections quand on soude ou quand on regarde l'arc.
 - b. Porter des vêtements convenables afin de protéger la peau de soudeur et des aides contre le rayonnement de l'arc.
 - c. Protéger l'autre personnel travaillant à proximité au soudage à l'aide d'écrans appropriés et non-inflammables.
4. Des gouttes de laitier en fusion sont émises de l'arc de soudage. Se protéger avec des vêtements de protection libres de l'huile, tels que les gants en cuir, chemise épaisse, pantalons sans revers, et chaussures montantes.
5. Toujours porter des lunettes de sécurité dans la zone de soudage. Utiliser des lunettes avec écrans latéraux dans les zones où l'on pique le laitier.

6. Eloigner les matériaux inflammables ou les recouvrir afin de prévenir tout risque d'incendie dû aux étincelles.
7. Quand on ne soude pas, poser la pince à un endroit isolé de la masse. Un court-circuit accidentel peut provoquer un échauffement et un risque d'incendie.
8. S'assurer que la masse est connectée le plus près possible de la zone de travail qu'il est pratique de le faire. Si on place la masse sur la charpente de la construction ou d'autres endroits éloignés de la zone de travail, on augmente le risque de voir passer le courant de soudage par les chaînes de levage, câbles de grue, ou autres circuits. Cela peut provoquer des risques d'incendie ou d'échauffement des chaînes et des câbles jusqu'à ce qu'ils se rompent.
9. Assurer une ventilation suffisante dans la zone de soudage. Ceci est particulièrement important pour le soudage de tôles galvanisées plombées, ou cadmiées ou tout autre métal qui produit des fumeés toxiques.
10. Ne pas souder en présence de vapeurs de chlore provenant d'opérations de dégraissage, nettoyage ou pistolage. La chaleur ou les rayons de l'arc peuvent réagir avec les vapeurs du solvant pour produire du phosgène (gas fortement toxique) ou autres produits irritants.
11. Pour obtenir de plus amples renseignements sur la sûreté, voir le code "Code for safety in welding and cutting" CSA Standard W 117.2-1974.

PRÉCAUTIONS DE SÛRETÉ POUR LES MACHINES À SOUDER À TRANSFORMATEUR ET À REDRESSEUR

1. Relier à la terre le châssis du poste conformément au code de l'électricité et aux recommandations du fabricant. Le dispositif de montage ou la pièce à souder doit être branché à une bonne mise à la terre.
2. Autant que possible, l'installation et l'entretien du poste seront effectués par un électricien qualifié.
3. Avant de faire des travaux à l'intérieur de poste, la débrancher à l'interrupteur à la boîte de fusibles.
4. Garder tous les couvercles et dispositifs de sûreté à leur place.

Mar. '93

Thank You

for selecting a **QUALITY** product by Lincoln Electric. We want you to take pride in operating this Lincoln Electric Company product ••• as much pride as we have in bringing this product to you!

CUSTOMER ASSISTANCE POLICY

The business of The Lincoln Electric Company is manufacturing and selling high quality welding equipment, consumables, and cutting equipment. Our challenge is to meet the needs of our customers and to exceed their expectations. On occasion, purchasers may ask Lincoln Electric for advice or information about their use of our products. We respond to our customers based on the best information in our possession at that time. Lincoln Electric is not in a position to warrant or guarantee such advice, and assumes no liability, with respect to such information or advice. We expressly disclaim any warranty of any kind, including any warranty of fitness for any customer's particular purpose, with respect to such information or advice. As a matter of practical consideration, we also cannot assume any responsibility for updating or correcting any such information or advice once it has been given, nor does the provision of information or advice create, expand or alter any warranty with respect to the sale of our products.

Lincoln Electric is a responsive manufacturer, but the selection and use of specific products sold by Lincoln Electric is solely within the control of, and remains the sole responsibility of the customer. Many variables beyond the control of Lincoln Electric affect the results obtained in applying these types of fabrication methods and service requirements.

Subject to Change – This information is accurate to the best of our knowledge at the time of printing. Please refer to www.lincolnelectric.com for any updated information.

Please Examine Carton and Equipment For Damage Immediately

When this equipment is shipped, title passes to the purchaser upon receipt by the carrier. Consequently, Claims for material damaged in shipment must be made by the purchaser against the transportation company at the time the shipment is received.

Please record your equipment identification information below for future reference. This information can be found on your machine nameplate.

Product _____

Model Number _____

Code Number or Date Code _____

Serial Number _____

Date Purchased _____

Where Purchased _____

Whenever you request replacement parts or information on this equipment, always supply the information you have recorded above. The code number is especially important when identifying the correct replacement parts.

On-Line Product Registration

- Register your machine with Lincoln Electric either via fax or over the Internet.
 - For faxing: Complete the form on the back of the warranty statement included in the literature packet accompanying this machine and fax the form per the instructions printed on it.
 - For On-Line Registration: Go to our **WEB SITE at www.lincolnelectric.com**. Choose "Quick Links" and then "Product Registration". Please complete the form and submit your registration.

Read this Operators Manual completely before attempting to use this equipment. Save this manual and keep it handy for quick reference. Pay particular attention to the safety instructions we have provided for your protection. The level of seriousness to be applied to each is explained below:

WARNING

This statement appears where the information **must** be followed **exactly** to avoid **serious personal injury** or **loss of life**.

CAUTION

This statement appears where the information **must** be followed to avoid **minor personal injury** or **damage to this equipment**.

	Page
Installation	Section A
Input Power Connection	A-1
Duty Cycle	A-1
Output Connections	A-1
<hr/>	
Operating Instructions	Section B
<hr/>	
Accessories	Section C
<hr/>	
Maintenance	Section D
<hr/>	
Troubleshooting	Section E
Troubleshooting Procedures	E-7 – E-10
<hr/>	
Wiring Diagrams	Section F
<hr/>	
Parts Lists	P206 Series

INSTALLATION

⚠ WARNING



FALLING EQUIPMENT can cause injury.

- Do not lift this machine using lift bail if it is equipped with a heavy accessory such as trailer or gas cylinder.

- Lift only with equipment of adequate lifting capacity.
- Be sure machine is stable when lifting.

The machine should be located in a clean, dry place where there is free circulation of clean air, such that air movement entering the front and exiting the back will not be restricted. Dirt and dust that can be drawn into the machine should be kept to a minimum. Failure to observe these precautions can result in excessive operating temperatures and nuisance shutdown of the machine.

The Idealarc R3R welders can be stacked three high when the following precautions are observed:

1. Be sure the bottom machine is on a firm, level surface suitable for the total weight [up to 1340 pounds (608 kg)] of the stacked machines.
2. Stack the machines with the fronts flush. Be certain the pins on the top front corners of the lower machines fit through the holes in the base rails of the upper machines.
3. No unit heavier than the bottom unit should be stacked on top of it. For example, an R3R 500-I shall not be slacked on top of an R3R 400-I, but an R3R 400-I may be stacked on top of an R3R 500-I.

INPUT POWER CONNECTION

⚠ WARNING



ELECTRIC SHOCK can kill.

- Have an electrician install and service this equipment.
- Turn the input power off at the fuse box before working on equipment.

- Do not touch electrically hot parts.

Remove the rear access panel. Connect the three phase input power to the three line terminals on the input contactor, and the earth ground lead to the ground stud marked with the \equiv symbol. Install the reconnect panel for the proper input voltage per the diagram pasted inside the access panel cover.

R3R Welder	Input Volts 50/60 Hz	Amps Input	Copper Wire Size Type 75°C in Conduit		Super Lag Fuse Size in Amps
			3 Input Wires	1 Ground Wire	
375-I	220	67	8	8	80
	380	39	10	10	60
	440	34	10	10	40
500-I	220	90	6	6	125
	380	52	8	8	80
	415-440	45	10	10	60
600-I	220	103	4	6	150
	380	60	8	8	90
	440	52	8	8	70

DUTY CYCLE

The maximum output rating of this welder is at a 35% duty cycle. Duty cycle is based on a ten minute period. Therefore, the welder can be operated at the maximum rated output for 3.5 minutes out of every 10 minute period without overheating.

⚠ CAUTION

Failure to follow these instructions can cause immediate failure of components within the machine.

When powering welder from a generator be sure to turn off welder first, before generator is shut down, in order to prevent damage to welder!

OUTPUT CONNECTIONS

With the machine power switch off, the output leads are connected to the Magnum™ Twist-Mate™ output terminals marked “-” and “+”. They are located at the lower right and lower left corners of the front panel. Strain relief for the electrode and work cables is provided by routing the leads through the rectangular holes in the base before the connections to the output terminals are made. Twist-Mate Lead plugs must be installed to the output cables before connections can be made to the power source. See S18737 instructions included with the plugs.

The recommended output cable sizes can be found in the Table below.

Machine Size	Up to 100 ft. (30 m)	100 to 150 ft. (30 – 46 m)	150 to 200 ft. (46 – 61 m)	200 to 250 ft. (61 – 76 m)
375-I	1/0 (54 mm ²)	1/0 (54 mm ²)	2/0 (68 mm ²)	3/0 (86 mm ²)
500-I	2/0 (68 mm ²)	2/0 (68 mm ²)	3/0 (86 mm ²)	4/0 (108 mm ²)
600-I	2/0 (68 mm ²)	3/0 (86 mm ²)	3/0 (86 mm ²)	4/0 (108 mm ²)

IDEALARC® R3R 375-I, 500-I AND 600-I

OPERATION

⚠ WARNING



ELECTRIC SHOCK can kill.

- Do not touch electrically live parts or electrode with skin or wet clothing.
- Insulate yourself from work and ground.
- Always wear dry insulating gloves.



FUMES AND GASES can be dangerous.

- Keep your head out of fumes.
- Use ventilation or exhaust to remove fumes from breathing zone.



WELDING SPARKS can cause fire or explosion.

- Keep flammable material away.
- Do not weld on containers that have held combustibles.



ARC RAYS can burn.

- Wear eye, ear and body protection.

STARTING THE MACHINE

The “power on-off” switch on the machine control panel energizes the three phase line contactor from a small 115 volt pilot transformer. This in turn energizes the main power transformer.

NOTE: All PC boards are protected by a moisture resistant coating. When the welder is operated, this coating will “bake off” of certain power resistors that normally operate at high temperatures, emitting some smoke and odor for a short time. These resistors and the PC board beneath them may become blackened. This is a normal occurrence and does not damage the component or affect the machine performance.

PILOT LIGHT

The while light on the machine control panel indicates when The line contactor is energized.



NOTE: If the amber High Temperature Warning Light is lit, it indicates that one or both of the protective thermostats has opened the line contactor.

OUTPUT CONTROL

The “current control” dial (labeled “I”) on the front of the machine indicates the output current.

On the R3R 375-I, there is only one dial. On the R3R 500-I, and 600-I, there are two dials. The “A” range controls the current over about 1/2 of the “B” range. A toggle switch on the control panel allows selection of the desired range. The output control can be adjusted while welding.

MACHINE OR REMOTE CURRENT CONTROL SWITCH

Provisions for remote control are standard on each power source. A current control switch on the machine control panel labeled “” or “ I ” is provided for selecting the desired mode of operation, either remote () or at the machine (I).

ARC FORCE CONTROL

The arc force control, located on the right side of the front control panel, is calibrated from one to ten. For most welding, the dial should be set at approximately mid-range, 5-6. Adjustments up or down can then be made depending on the electrode, procedures, and operator preference. Lower settings will provide less short circuit current and a softer arc. A setting that is too low may cause the electrode to stick in the puddle. Higher settings will provide a higher short circuit current and a more forceful arc. Excessive spatter may result if the control setting is too high. For most TIG welding applications, adjust this control to minimum for best operating characteristics.

INTERNATIONAL SYMBOLOGY REFERENCE

The R3R nameplates feature international symbols in describing the function of the various components. Below are the symbols used and an explanation of what each represents.

A. POWER ON-OFF SWITCH

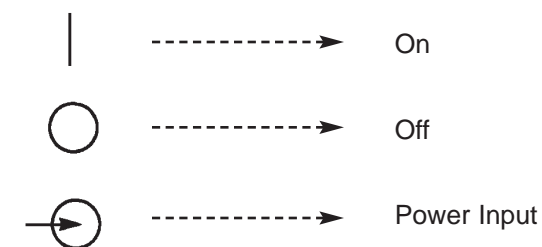

IDEALARC® R3R 375-I, 500-I AND 600-I

B. ARC FORCE CONTROL DIAL



Arc Force



Increase/Decrease of Arc Force

C. OUTPUT CURRENT CONTROL DIAL



Output Current

D. OUTPUT CURRENT CONTROL RANGE SWITCH (R3R 500-I and R3R 600-I only)



Output Current Control Dial Range A



Output Current Control Dial Range B

E. OUTPUT CURRENT CONTROL "MACHINE-REMOTE" SWITCH



Remote Output Current Control

F. POLARITY SWITCH (Factory installed option on domestic models only)



Electrode Polarity Positive



Electrode Polarity Negative



Do Not Switch While Welding

G. RATING PLATE



Three Phase Power



Transformer



Rectifier



Rectified DC Output



Constant Current Characteristics



Shielded Metal Arc Welding



Line Connection

H. HIGH TEMPERATURE WARNING LIGHT



High Temperature Limit

I. WARNING



Warning Identification

J. GROUND



Signifying the Earth (Ground) Connection

OPTIONAL EQUIPMENT

K857 – REMOTE CURRENT CONTROL

The K857 consists of a control box with 8.5 m (28 ft) of four conductor cable and a 6 pin Amphenol for easy connection to the front of the power source.

The K857 will give the same control as the current control on the machine depending on the position of the current dial selector switch. (Current dial selector switch not used on the R3R 375-I.)

- b. Turn the welder power switch on.
- c. Insert one end of the probe into the electrode holder and hold the other end on the work for approximately five seconds.

AMMETER AND VOLTMETER – (factory installed only)

CAUTION

Extreme care must be observed when installing or extending the wiring of a remote control. The Remote Control cord can be lengthened to any length by splicing four wires to the standard 28 ft (8.5 m) cord before connecting to the R3R receptacle. Only the green lead can and should be grounded to the machine case.

K817, K817R – UNDERCARRIAGE

For easy moving of the machine, optional undercarriages are available with either steel or rubber tire wheels.

K963 – HAND AMPTROL AND K870 FOOT AMPTROL

Connect directly to the 6 pin Amphenol on the front of the power source.

POCKET AMPTROL – (factory installed only)

The Pocket Amptrol option provides a remote current control for the R3R welders. This “wireless” control requires no control cable connection to the welder.

- a. On the R3R 500-I and R3R 600-I the welder Current Control (labeled “ I “ switch must be in the Remote () position and the Current Dial Selector switch in the “B” range. The R3R 375-I has only one Current Dial Selector and no selector switch. With the Current Control switch in the Remote position, the current control potentiometer on the welder is removed from the circuit and its setting has no effect on the output. With the Current Dial Selector switch in the “B” range position, the Pocket Amptrol provides total control of the welder’s output.

⚠ WARNING

ELECTRIC SHOCK can kill.

- Have an electrician install and service this equipment.
 - Turn the input power off at the fuse box before working on equipment.
- Do not touch electrically hot parts.

ROUTINE MAINTENANCE

1. The fan motor has sealed bearings which require no service.
2. In extremely dusty locations, dirt may clog the air channels causing the welder to run hot. Blow out the machine at regular intervals.

POCKET AMPTROL

Routine cleaning should be the only maintenance required. The probe tip should be kept in condition to provide sharp edges at the ends to assure penetration of heavy oxide coatings on the work piece. A blunted tip could result in giving different welding currents for a given dial setting.

POWER RECTIFIER REPLACEMENT

Refer to the troubleshooting section "Power Rectifier Bridge Assembly Checking Procedure" if a rectifier failure is suspected

NOTE: Since proper material and correct assembly procedures are critical, field disassembly of the power rectifier bridge sections can do more harm than good. Return a defective rectifier bridge section (or the entire bridge) to the factory for repairs.

HOW TO USE TROUBLESHOOTING GUIDE

WARNING

Service and Repair should only be performed by Lincoln Electric Factory Trained Personnel. Unauthorized repairs performed on this equipment may result in danger to the technician and machine operator and will invalidate your factory warranty. For your safety and to avoid Electrical Shock, please observe all safety notes and precautions detailed throughout this manual.

This Troubleshooting Guide is provided to help you locate and repair possible machine malfunctions. Simply follow the three-step procedure listed below.

Step 1. LOCATE PROBLEM (SYMPTOM).

Look under the column labeled “PROBLEM (SYMPTOMS)”. This column describes possible symptoms that the machine may exhibit. Find the listing that best describes the symptom that the machine is exhibiting.

Step 2. POSSIBLE CAUSE.

The second column labeled “POSSIBLE CAUSE” lists the obvious external possibilities that may contribute to the machine symptom.

Step 3. RECOMMENDED COURSE OF ACTION

This column provides a course of action for the Possible Cause.

If you do not understand or are unable to perform the Recommended Course of Action safely, contact your local Lincoln Authorized Field Service Facility.

WARNING



ELECTRIC SHOCK can kill.

- Do not touch electrically hot parts.
- Have an electrician install and service this equipment.
- Turn the input power off at the fuse box before working on equipment.

CAUTION

If for any reason you do not understand the test procedures or are unable to perform the tests/repairs safely, contact your **Local Lincoln Authorized Field Service Facility** for technical troubleshooting assistance before you proceed.

IDEALARC® R3R 375-I, 500-I AND 600-I



Observe all Safety Guidelines detailed throughout this manual

PROBLEMS (SYMPTOMS)	POSSIBLE CAUSE	RECOMMENDED COURSE OF ACTION
FUNCTION PROBLEMS		
A. Input contactor chatters.	1. Faulty input contactor. 2. Low line voltage.	1. Repair or replace. 2. Check with Power Company.
B. Machine input contactor does not operate.	1. Supply line fuse blown. 2. Power circuit dead. 3. Broken or loose power lead. 4. Wrong voltage. 5. Thermostats tripped. (High Temperature Warning Light should be lit.) (Welder overheated.) 6. Input contactor coil open. 7. Open winding on 115V pilot transformer. 8. Power ON-OFF switch not closing. 9. Lead broken or loose connection in 115V starter circuit. 10. Thermostats defective. (High Temperature Warning Light should be lit.)	1. Replace (look for reason for blown fuse first). 2. Check voltage. 3. Repair. 4. Check voltage against instructions. 5. a. Make sure the fan is operating and that there are no obstructions to free flow of air. b. Operate at normal current and duty cycle. c. Replace High Temperature Warning Light if defective. 6. Replace. 7. Replace. 8. Replace. 9. Replace. 10. Turn input power off (115V circuit is hot when input power is connected). Check thermostats with continuity meter – should read short-circuit when machine is cool. Replace if defective. There are two thermostats; one on the secondary lead and one on the choke. Replace High Temperature Warning Light if defective.

 **CAUTION**

If for any reason you do not understand the test procedures or are unable to perform the tests/repairs safely, contact your **Local Lincoln Authorized Field Service Facility** for technical troubleshooting assistance before you proceed.

IDEALARC® R3R 375-I, 500-I AND 600-I



Observe all Safety Guidelines detailed throughout this manual

PROBLEMS (SYMPTOMS)	POSSIBLE CAUSE	RECOMMENDED COURSE OF ACTION
FUNCTION PROBLEMS		
<p>C. Machine input contactor closes but has no or low output. Open circuit voltage should be 67 to 71 volts.</p>	<ol style="list-style-type: none"> 1. Electrode or work lead loose or broken. 2. Open transformer primary or secondary circuit. 3. Supply line fuse blown. 4. Input line grounded causing single phase input. 5. Input leads not connected to contactor. 6. Latching resistor, R3, open. 7. Control circuit problems. 	<ol style="list-style-type: none"> 1. Repair connections. 2. Repair. 3. Replace blown fuse – check fuse size. 4. Repair input to machine. 5. Connect input lead. 6. a. Replace. b. Check leads to the resistor and repair if defective. 7. See Troubleshooting Procedures – Power Silicon Controlled Rectifier.
<p>D. Machine has maximum output but no control.</p>	<ol style="list-style-type: none"> 1. Possible defective power SCR. 2. Possible defective control board. 	<ol style="list-style-type: none"> 1. Remove all gate leads G1, G2 and G3 at PC board connector J4. If welder has any open circuit voltage, power SCR is defective. See Troubleshooting Procedures Section J. 2. See PC board Troubleshooting Procedures Section A

 **CAUTION**

If for any reason you do not understand the test procedures or are unable to perform the tests/repairs safely, contact your **Local Lincoln Authorized Field Service Facility** for technical troubleshooting assistance before you proceed.

IDEALARC® R3R 375-I, 500-I AND 600-I



Observe all Safety Guidelines detailed throughout this manual

PROBLEMS (SYMPTOMS)	POSSIBLE CAUSE	RECOMMENDED COURSE OF ACTION
FUNCTION PROBLEMS		
E. Machine does not have maximum output (67 to 71 volts).	<ol style="list-style-type: none"> 1. Input fuse blown. Machine is single phased. 2. One phase of main transformer windings open. 3. Defective power bridge. 	<ol style="list-style-type: none"> 1. Replace fuse or repair input line. Check reason for fault. 2. Repair. 3. Check bridge per Troubleshooting Procedures Section J and check snubber per Section F.
F. Machine comes on but soon trips off while under load and High Temperature Warning Light glows. (Thermostat tripped)	<ol style="list-style-type: none"> 1. Improper ventilation. 2. Loaded beyond rating. 3. Fan inoperative. 4. Shorted diode or SCR in power rectifier bridge. 	<ol style="list-style-type: none"> 1. Make sure all case openings are free for proper circulation of air. 2. Operate at rated current and duty cycle. 3. Check leads and motor bearings. Fan can be tested on 115 volt line. 4. Refer to Troubleshooting Procedures Section J and Snubber, Section F.
G. Machine comes on but reduces to low output under load and remains there until the load is broken and arc restarted. See Fault Protection Troubleshooting Section E.	<ol style="list-style-type: none"> 1. Excessive load causing the overload protection on control board to operate. 2. Machine output shorted causing overload protection on control board to operate. 3. Control circuit defective. 	<ol style="list-style-type: none"> 1. Reduce load. 2. Turn machine off and remove short. 3. Replace per PC board, Troubleshooting, Section A.

 **CAUTION**

If for any reason you do not understand the test procedures or are unable to perform the tests/repairs safely, contact your **Local Lincoln Authorized Field Service Facility** for technical troubleshooting assistance before you proceed.

IDEALARC® R3R 375-I, 500-I AND 600-I



Observe all Safety Guidelines detailed throughout this manual

PROBLEMS (SYMPTOMS)	POSSIBLE CAUSE	RECOMMENDED COURSE OF ACTION
FUNCTION PROBLEMS		
H. Machine trips off when under no load or makes excessive noise like it is loaded.	<ol style="list-style-type: none"> 1. Power bridge rectifier may have a shorted diode or SCR. 2. Short in the transformer. 3. Fan hitting vertical baffle. 	<ol style="list-style-type: none"> 1. Refer to Power Hybrid, Troubleshooting Procedures, Section J and Snubber, Section F. 2. Repair. 3. Clear the fan.
I. Variable or sluggish welding arc.	<ol style="list-style-type: none"> 1. Poor work or electrode cable connection. 2. Current too low. 3. Welding leads too small. 4. Open SCR or diode in power rectifier bridge. 5. Control circuit problems. 	<ol style="list-style-type: none"> 1. Check and clean cable connections. 2. Check recommended currents for rod type and size. 3. See Table in Output Connection Section. 4. Check per Power Rectifier Bridge Troubleshooting Procedures, Section J and Snubber, Section F. 5. See SCR Troubleshooting, Section K.
J. Welder will not shut off.	<ol style="list-style-type: none"> 1. Input contactor contacts frozen. 	<ol style="list-style-type: none"> 1. Replace input contactor.
K. Current control on machine not functioning.	<ol style="list-style-type: none"> 1. Current control switch in wrong position. 2. Current control switch defective. 3. Current control potentiometer defective. 4. Lead or connection in control circuit open. 5. Defective control or circuit boards. 	<ol style="list-style-type: none"> 1. Place switch in "machine" (I) position. 2. Check per Section H. 3. Check per Section G. 4. Repair or connect. 5. See SCR Troubleshooting, Section K.

 **CAUTION**

If for any reason you do not understand the test procedures or are unable to perform the tests/repairs safely, contact your **Local Lincoln Authorized Field Service Facility** for technical troubleshooting assistance before you proceed.

IDEALARC® R3R 375-I, 500-I AND 600-I



Observe all Safety Guidelines detailed throughout this manual

PROBLEMS (SYMPTOMS)	POSSIBLE CAUSE	RECOMMENDED COURSE OF ACTION
FUNCTION PROBLEMS		
<p>L. Optional remote current control not functioning. See Troubleshooting , Section C before connecting.</p>	<ol style="list-style-type: none"> 1. Current control switch in the wrong position. 2. Leads 75, 76 and 77 not connected to correct numbers on models with terminal strip. 3. Remote control leads broken. 4. Remote control potentiometer open. 5. Lead or connection in current control circuit open. 6. Control PC board plug disconnected or loose. 7. Control circuit problems. 	<ol style="list-style-type: none"> 1. Place switch in "remote" () position. 2. Correct connection. 3. Repair broken leads. 4. See Troubleshooting, Section C. 5. Connect or repair. 6. Connect plug. 7. See SCR Troubleshooting, Section K.

 **CAUTION**

If for any reason you do not understand the test procedures or are unable to perform the tests/repairs safely, contact your **Local Lincoln Authorized Field Service Facility** for technical troubleshooting assistance before you proceed.

IDEALARC® R3R 375-I, 500-I AND 600-I



**CONTROL CIRCUIT
TROUBLESHOOTING CHART**

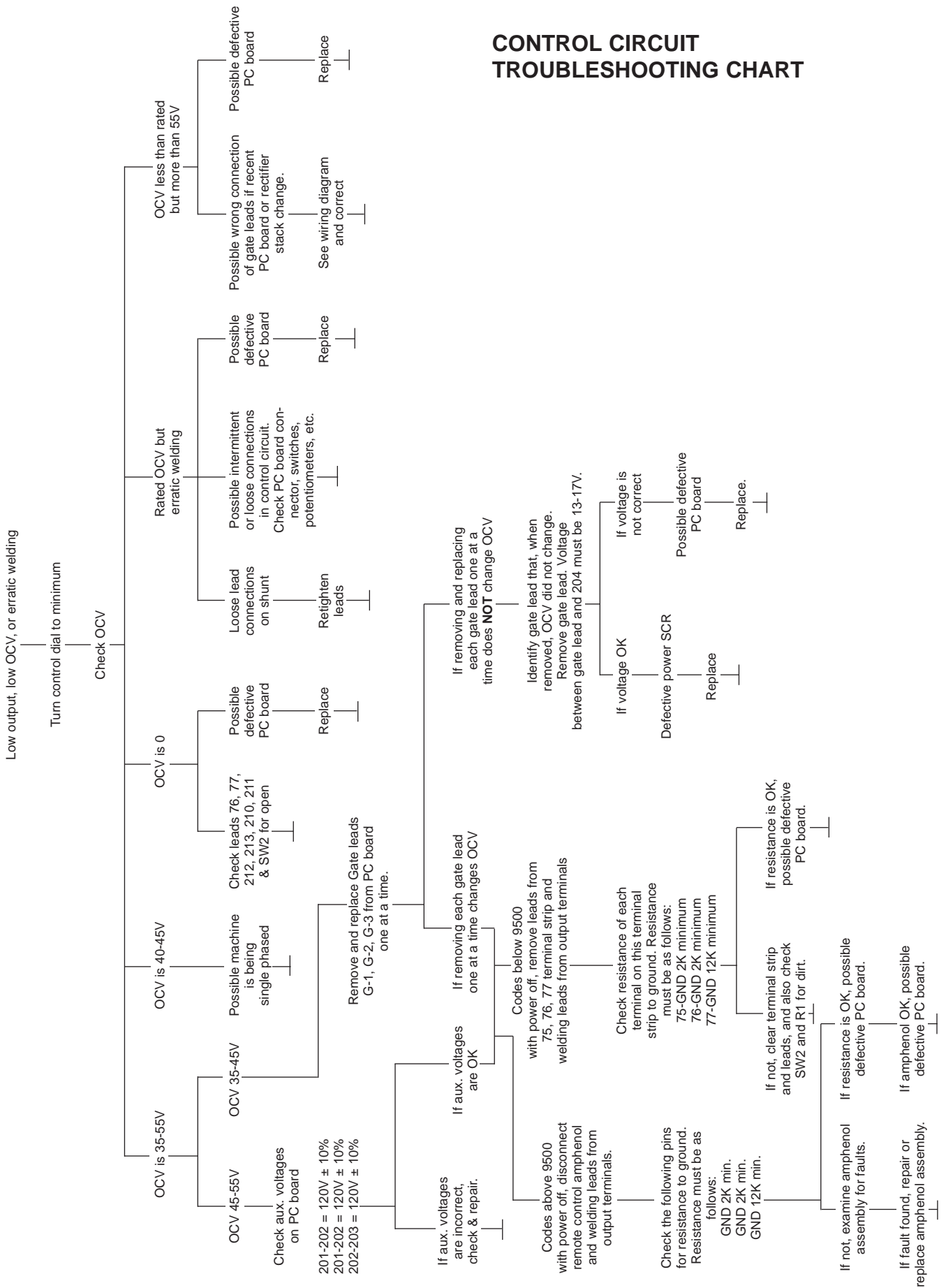

TROUBLESHOOTING PROCEDURES

A. PROCEDURE FOR REPLACING PC BOARDS

When a PC board is to be replaced, the following procedure must be followed:

1. Visually inspect PC board in question. Are any of the components damaged? Is a conductor on the back side of the board damaged?
 - a. If there is no damage to the PC board, insert a new one and see if this remedies the problem. If the problem is remedied replace the old PC board and see if the problem still exists with the old PC board.
 1. If the problem does not exist with the old board, check the PC board harness plug and PC board plug for corrosion, contamination, or oversize.
 2. Check leads in the harness for loose connections.
 - b. If there is damage to the PC board, refer to the Troubleshooting Guide.

B. PROCEDURE FOR CHECKING DIODES

1. Isolate the diode in question. (Electrically disconnect from other circuits.)
2. Use an ohmmeter X10 scale. Connect the meter across the diode and note the resistance value. Reverse the ohm-meter leads and note the resistance value.

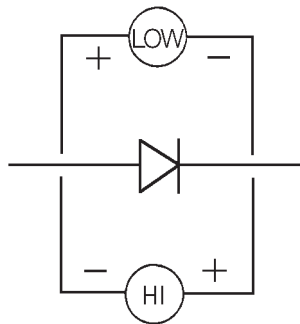

Shorted diode – Low resistance readings in both directions.

Open diode – High or infinite resistance in both directions.

Good diode – One reading will be high or infinite and the other reading will be low.

C. CONNECTING THE REMOTE CONTROL TO THE MACHINE

Extreme caution must be observed when installing or extending the wiring of a remote control. Improper connection of this unit can lead to failure of the current control rheostat or the control circuit. Only the green lead can and should be grounded to the machine case. When extending the standard remote control make sure the leads are the same and the splice is waterproof. Be very careful not to ground the cable when in use and do not let these connections touch against the case.

D. OUTPUT VOLTAGE

The open circuit voltage of the machine should be 66 to 71 volts and should not vary when the rheostat is varied unless the machine is welding. If any other condition exists, refer to the Troubleshooting Guide.

E. FAULT PROTECTION OPERATION

The overload protection circuit, in the control board, will reduce the welding current (heat) to some safe value if the machine is overloaded for 2 to 3 seconds. The overload values are as appears in the following table.

Machine Name	f	Load Current $\pm 5\%$
R3R 375-I R3R 500-I R3R 600-I	50 Hz	100 A

F. CHECKING SNUBBER CIRCUIT

In case of an SCR malfunction or failure, the snubber assembly should be checked. Turn the machine off and disconnect one lead of the snubber assembly. (Either 221, 222 or 223 depending on the SCR in question. See wiring diagram.) The sides of the machine have to be removed to do this. (See the instruction manual parts list for the exact location.)

1. Visually inspect the snubber assembly for overheated components.
2. Using a VOM meter on the X10 scale, connect the positive lead to the lead removed. Touch the negative lead to the other lead still connected to the SCR bridge. The indicating needle on the meter will move quickly to the right (low resistance value) and then slowly return to the left

(high resistance value). This indicates that the capacitor in the snubber circuit is taking a charge.

3. If the needle stays to the right, the capacitor is shorted and the assembly is defective.
4. If the needle does not move, the capacitor is open and the assembly is defective.

G. CHECKING CURRENT CONTROL RHEOSTAT ON MACHINE

1. Turn machine off.
2. Remove the control panel screws and open the front cover.
3. Turn the current control switch to remote.
4. Disconnect the harness plug from the control board.
5. Put current range switch to B range.
6. With an ohmmeter on X1K, connect it to lead 210 and 211 on SW #2. Rotate the current control rheostat. The resistance reading should be from around zero to 10K ohms. Check the resistance reading between 75 on the terminal strip (codes below 9500) or Amphenol (codes above 9500), and 211 on SW #2. The reading must be 10K ohms. No reading will indicate an open rheostat and low reading will indicate a shorted or partially shorted rheostat; in either case, replace.

H. TOGGLE SWITCH CHECK

1. Turn off the machine power input. SW-1 has 110 volts across it when the input power is connected.
2. Isolate the switch to be tested by removing all connecting leads.
3. Check to make sure the switch is making connections with a VOM meter. The meter should read zero resistance.
4. Put the ohmmeter on X1K scale and measure the resistance between the terminal and the case of the machine (touch a self-tapping screw). Reading should be infinite.

5. If either step (3) or step (4) fails, replace the switch.

I. REMOTE CONTROL CHECK

For codes above 9500, the remote control Amphenol pin assignments are: pin C-75, pin B-76, and pin A-77. Disconnect the remote field control and connect an ohmmeter across 75 and 76 and rotate the rheostat in the remote control. The resistance reading should go from zero to 10K ohms. Repeat with triplet across 77 and 76 with same results. Connect ohmmeter across 75 and 77. The reading should be 10K ohms. A lower reading will indicate a shorted or partially shorted rheostat. A very high reading will indicate an open rheostat. In either of the last two cases, replace rheostat. Check cable for any physical damage.

J. POWER RECTIFIER BRIDGE ASSEMBLY CHECKING PROCEDURE

CAUTION

The rectifier bridge tests outlined below will identify the most common effects found in power diodes or power silicon controlled rectifiers. If a bridge problem still exists after test, please call a Lincoln Field Service Shop. Further evaluation of diodes or silicon controlled rectifiers may require laboratory equipment.

1. **DEVICE ISOLATION** (see the instruction manual Parts List for the exact location)

Disconnect the following leads from the bridge, shown in Diagram 1:

- a. Wiring harness gate leads (G1, G2, G3) from the gate lead terminals⁽¹⁾ on the Control PC board.
- b. AC leads X1, X2 and X3 from the anodes of the SCR's and cathodes of the diodes.
- c. The 220, 221 and 223 leads from the Snubber PC board.
- d. Lead 220 that connects to the latching resistor (R3).
- e. The cathode of each diode (4 total).

⁽¹⁾ Connector J4 on latest control board.

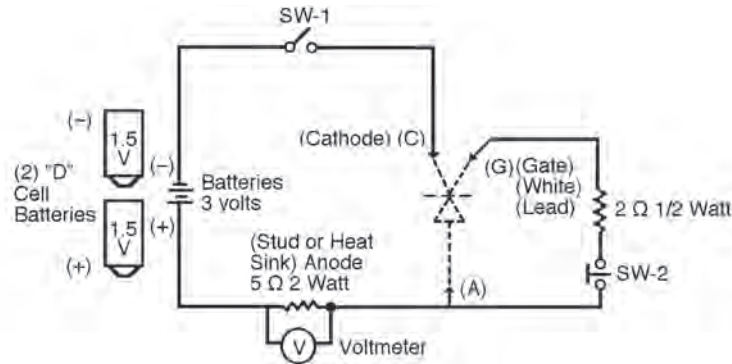

DIAGRAM 1

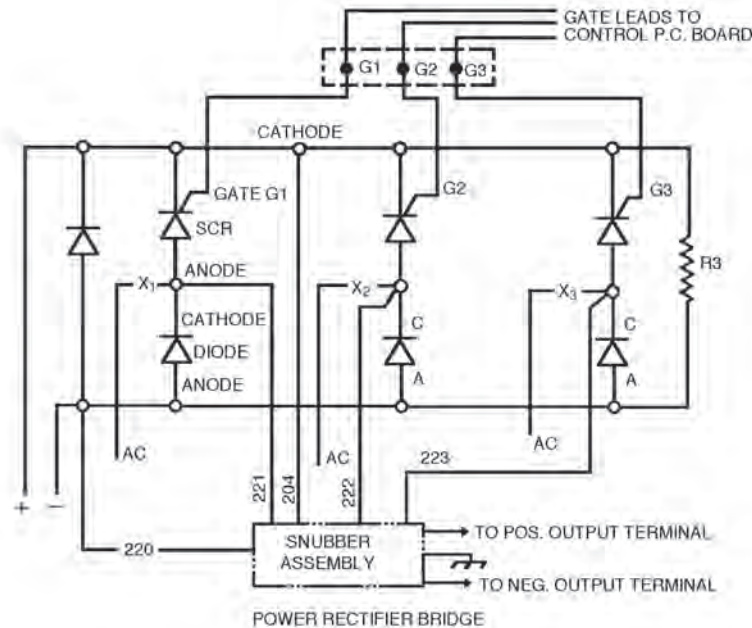

DIAGRAM 2

2. POWER DIODE TEST

- Establish the polarity of the ohmmeter leads and set to X10 scale.
- Connect the ohmmeter positive lead to anode and negative lead to the cathode.
- Reverse the leads of the ohmmeter from Step b.
- A shorted diode will indicate zero or an equally low resistance in both directions. An open diode will have an infinite or high resistance in both directions, and a good diode will have a low resistance in Step b and a much higher resistance in Step c.

K. POWER SILICON CONTROLLED RECTIFIER TEST

The SCR must be mounted in the heat sink when making this test.

- Connect the ohmmeter (set to the X10 scale) leads to the anode and cathode.
- Reverse the leads of the ohmmeter from Step a.
- A shorted SCR will indicate zero or an equally low resistance in one or both directions.
- Establish the polarity of the ohmmeter. Connect the positive lead to the gate and the negative lead to the cathode.
- An open gate circuit will have an infinite or high resistance. A good gate circuit will read a low resistance, but not zero ohms.

IDEALARC R3R-400, 500-I, 500 & 600-I WIRING DIAGRAM

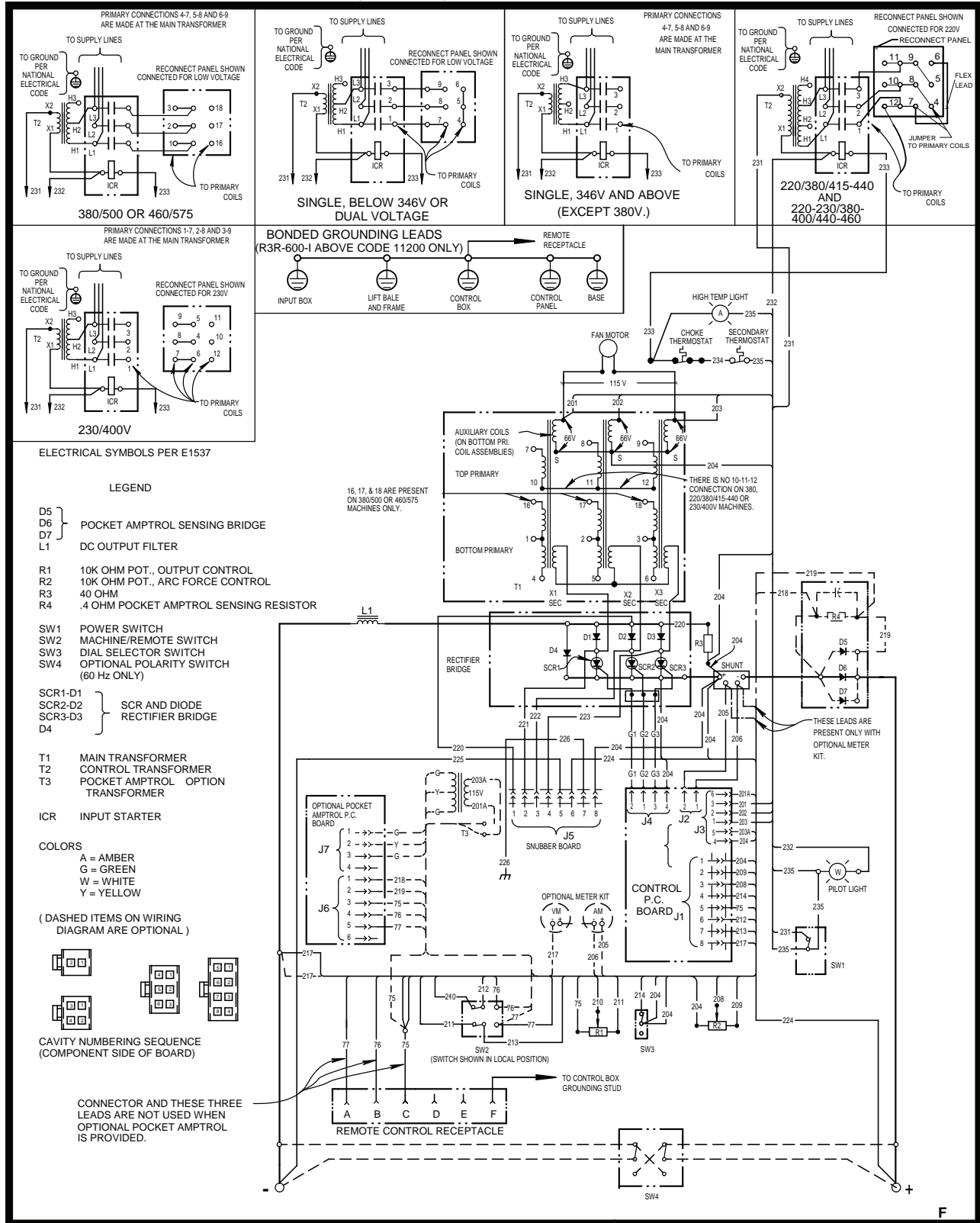

L9376

NOTE: This diagram is for reference only. It may not be accurate for all machines covered by this manual. The specific diagram for a particular code is pasted inside the machine on one of the enclosure panels.

IDEALARC® R3R 375-I, 500-I AND 600-I



IDEALARC R3R WIRING DIAGRAM (230/460/575 V) (FOR CANADA ONLY)

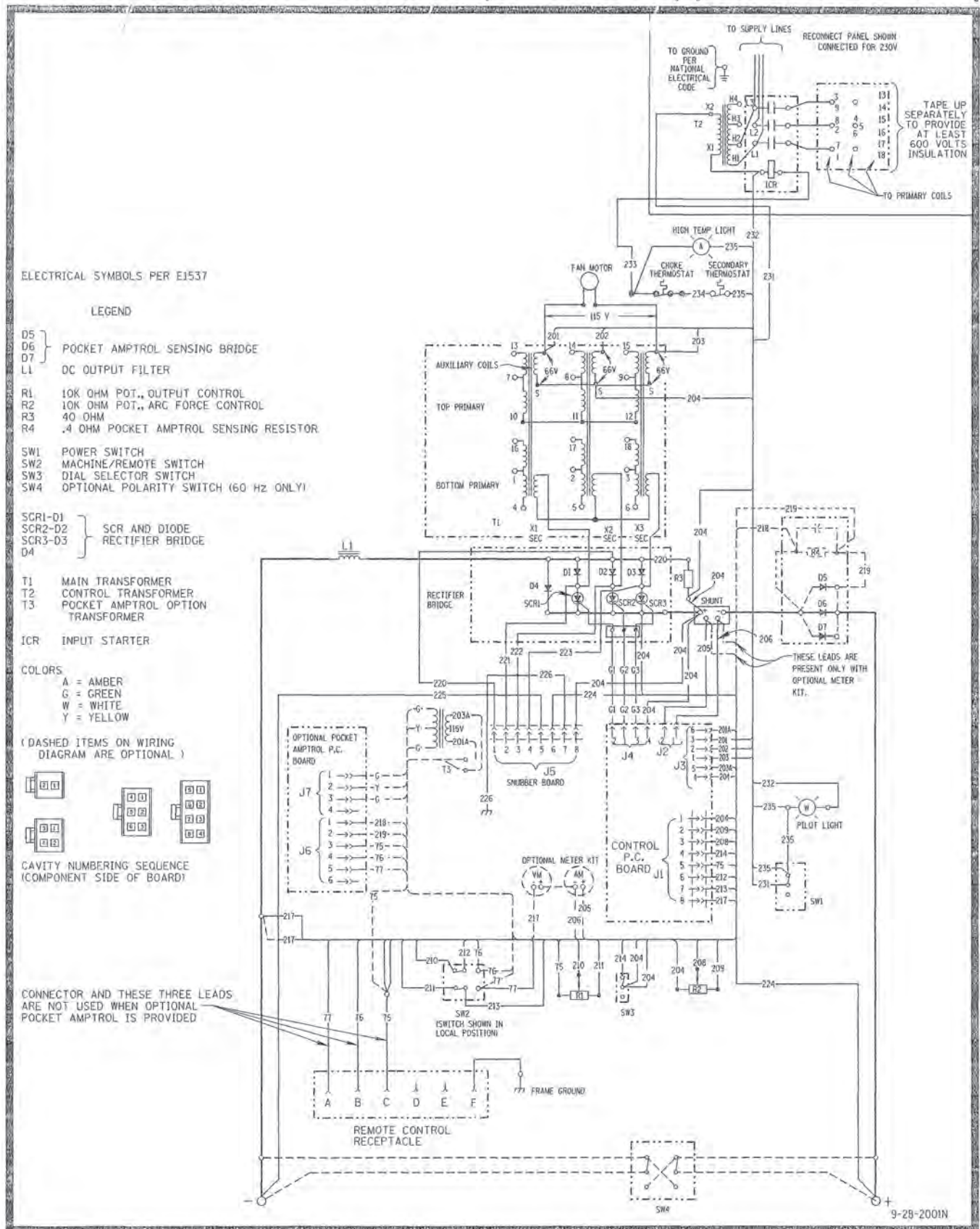

L8184

NOTE: This diagram is for reference only. It may not be accurate for all machines covered by this manual. The specific diagram for a particular code is pasted inside the machine on one of the enclosure panels.

IDEALARC® R3R 375-I, 500-I AND 600-I



R3R 375-I, 500-I and 600-I
 K817 or K817R
 (K841 not shown)

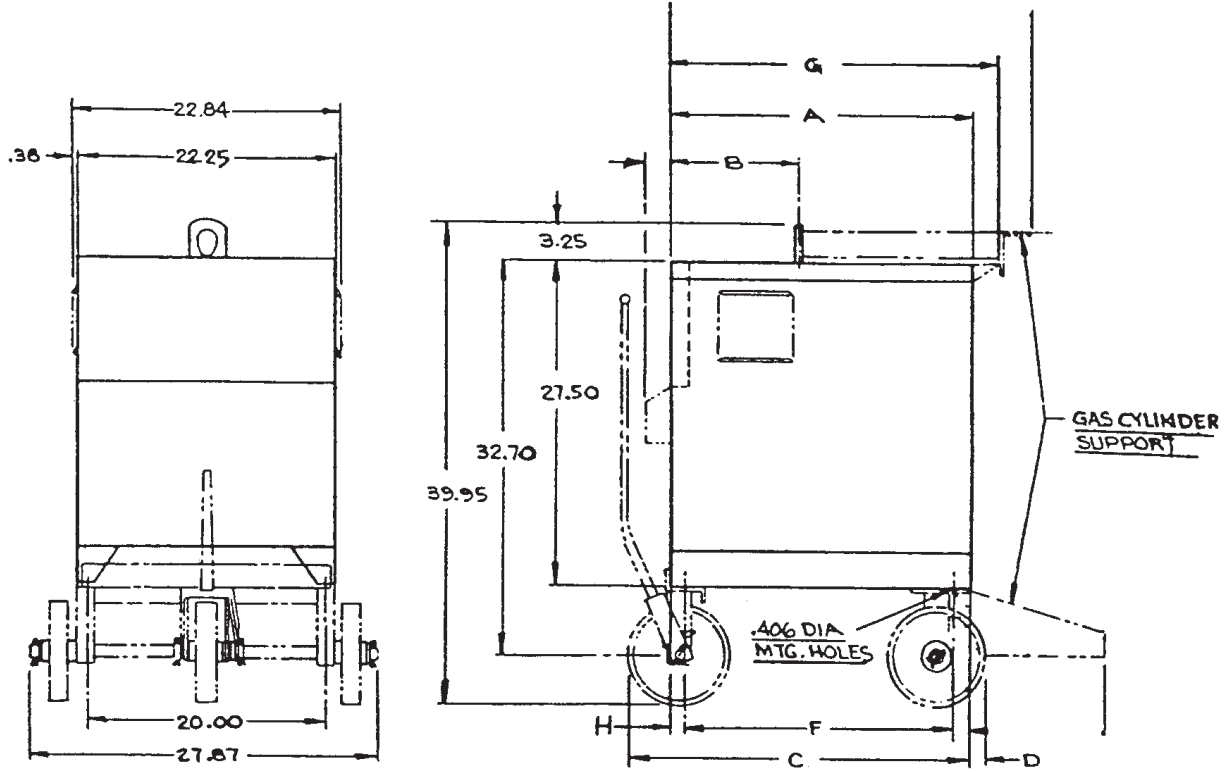

N.A-OPTIONAL UNDERCARRIAGE AVAILABLE

Part No.	Type	A	B	C	D	F	G	H
M12244-7	R3R	32.00	15.39	3092	1.44	30.02±.11	33.07±.06	.94

M12244-7
 7-7-78

			
WARNING	<ul style="list-style-type: none"> ● Do not touch electrically live parts or electrode with skin or wet clothing. ● Insulate yourself from work and ground. 	<ul style="list-style-type: none"> ● Keep flammable materials away. 	<ul style="list-style-type: none"> ● Wear eye, ear and body protection.
Spanish AVISO DE PRECAUCION	<ul style="list-style-type: none"> ● No toque las partes o los electrodos bajo carga con la piel o ropa mojada. ● Aislese del trabajo y de la tierra. 	<ul style="list-style-type: none"> ● Mantenga el material combustible fuera del área de trabajo. 	<ul style="list-style-type: none"> ● Protéjase los ojos, los oídos y el cuerpo.
French ATTENTION	<ul style="list-style-type: none"> ● Ne laissez ni la peau ni des vêtements mouillés entrer en contact avec des pièces sous tension. ● Isolez-vous du travail et de la terre. 	<ul style="list-style-type: none"> ● Gardez à l'écart de tout matériel inflammable. 	<ul style="list-style-type: none"> ● Protégez vos yeux, vos oreilles et votre corps.
German WARNUNG	<ul style="list-style-type: none"> ● Berühren Sie keine stromführenden Teile oder Elektroden mit Ihrem Körper oder feuchter Kleidung! ● Isolieren Sie sich von den Elektroden und dem Erdboden! 	<ul style="list-style-type: none"> ● Entfernen Sie brennbares Material! 	<ul style="list-style-type: none"> ● Tragen Sie Augen-, Ohren- und Körperschutz!
Portuguese ATENÇÃO	<ul style="list-style-type: none"> ● Não toque partes elétricas e electrodos com a pele ou roupa molhada. ● Isole-se da peça e terra. 	<ul style="list-style-type: none"> ● Mantenha inflamáveis bem guardados. 	<ul style="list-style-type: none"> ● Use proteção para a vista, ouvido e corpo.
Japanese 注意事項	<ul style="list-style-type: none"> ● 通電中の電気部品、又は溶材にヒブやぬれた布で触れないこと。 ● 施工物やアースから身体が絶縁されている様にして下さい。 	<ul style="list-style-type: none"> ● 燃えやすいものの側での溶接作業は絶対にしてはなりません。 	<ul style="list-style-type: none"> ● 目、耳及び身体に保護具をして下さい。
Chinese 警告	<ul style="list-style-type: none"> ● 皮肤或湿衣物切勿接触带电部件及焊条。 ● 使你自己与地面和工件绝缘。 	<ul style="list-style-type: none"> ● 把一切易燃物品移离工作场所。 	<ul style="list-style-type: none"> ● 佩戴眼、耳及身体劳动保护用具。
Korean 위험	<ul style="list-style-type: none"> ● 전도체나 용접봉을 젖은 헝겍 또는 피부로 절대 접촉치 마십시오. ● 모재와 접지를 접촉치 마십시오. 	<ul style="list-style-type: none"> ● 인화성 물질을 접근 시키지 마십시오. 	<ul style="list-style-type: none"> ● 눈, 귀와 몸에 보호장구를 착용하십시오.
Arabic تحذير	<ul style="list-style-type: none"> ● لا تلمس الاجزاء التي يسري فيها التيار الكهربائي أو الأقطاب بجلد الجسم أو بالملابس المبللة بالماء. ● ضع عازلا على جسمك خلال العمل. 	<ul style="list-style-type: none"> ● ضع المواد القابلة للاشتعال في مكان بعيد. 	<ul style="list-style-type: none"> ● ضع أدوات وملابس واقية على عينيك وأذنيك وجسمك.

READ AND UNDERSTAND THE MANUFACTURER'S INSTRUCTION FOR THIS EQUIPMENT AND THE CONSUMABLES TO BE USED AND FOLLOW YOUR EMPLOYER'S SAFETY PRACTICES.

SE RECOMIENDA LEER Y ENTENDER LAS INSTRUCCIONES DEL FABRICANTE PARA EL USO DE ESTE EQUIPO Y LOS CONSUMIBLES QUE VA A UTILIZAR, SIGA LAS MEDIDAS DE SEGURIDAD DE SU SUPERVISOR.

LISEZ ET COMPRENEZ LES INSTRUCTIONS DU FABRICANT EN CE QUI REGARDE CET EQUIPMENT ET LES PRODUITS A ETRE EMPLOYES ET SUIVEZ LES PROCEDURES DE SECURITE DE VOTRE EMPLOYEUR.

LESEN SIE UND BEFOLGEN SIE DIE BETRIEBSANLEITUNG DER ANLAGE UND DEN ELEKTRODENEINSATZ DES HERSTELLERS. DIE UNFALLVERHÜTUNGSVORSCHRIFTEN DES ARBEITGEBERS SIND EBENFALLS ZU BEACHTEN.

IDEALARC® R3R 375-I, 500-I AND 600-I



			
<ul style="list-style-type: none"> ● Keep your head out of fumes. ● Use ventilation or exhaust to remove fumes from breathing zone. 	<ul style="list-style-type: none"> ● Turn power off before servicing. 	<ul style="list-style-type: none"> ● Do not operate with panel open or guards off. 	WARNING
<ul style="list-style-type: none"> ● Los humos fuera de la zona de respiración. ● Mantenga la cabeza fuera de los humos. Utilice ventilación o aspiración para gases. 	<ul style="list-style-type: none"> ● Desconectar el cable de alimentación de poder de la máquina antes de iniciar cualquier servicio. 	<ul style="list-style-type: none"> ● No operar con panel abierto o guardas quitadas. 	Spanish AVISO DE PRECAUCION
<ul style="list-style-type: none"> ● Gardez la tête à l'écart des fumées. ● Utilisez un ventilateur ou un aspirateur pour ôter les fumées des zones de travail. 	<ul style="list-style-type: none"> ● Débranchez le courant avant l'entretien. 	<ul style="list-style-type: none"> ● N'opérez pas avec les panneaux ouverts ou avec les dispositifs de protection enlevés. 	French ATTENTION
<ul style="list-style-type: none"> ● Vermeiden Sie das Einatmen von Schweißrauch! ● Sorgen Sie für gute Be- und Entlüftung des Arbeitsplatzes! 	<ul style="list-style-type: none"> ● Strom vor Wartungsarbeiten abschalten! (Netzstrom völlig öffnen; Maschine anhalten!) 	<ul style="list-style-type: none"> ● Anlage nie ohne Schutzgehäuse oder Innenschutzverkleidung in Betrieb setzen! 	German WARNUNG
<ul style="list-style-type: none"> ● Mantenha seu rosto da fumaça. ● Use ventilação e exaustão para remover fumo da zona respiratória. 	<ul style="list-style-type: none"> ● Não opere com as tampas removidas. ● Desligue a corrente antes de fazer serviço. ● Não toque as partes elétricas nuas. 	<ul style="list-style-type: none"> ● Mantenha-se afastado das partes moventes. ● Não opere com os painéis abertos ou guardas removidas. 	Portuguese ATENÇÃO
<ul style="list-style-type: none"> ● ヒュームから頭を離すようにして下さい。 ● 換気や排煙に十分留意して下さい。 	<ul style="list-style-type: none"> ● メンテナンス・サービスに取りかかる際には、まず電源スイッチを必ず切して下さい。 	<ul style="list-style-type: none"> ● パネルやカバーを取り外したまま機械操作をしないで下さい。 	Japanese 注意事項
<ul style="list-style-type: none"> ● 頭部遠離煙霧。 ● 在呼吸區使用通風或排風器除煙。 	<ul style="list-style-type: none"> ● 維修前切斷電源。 	<ul style="list-style-type: none"> ● 儀表板打開或沒有安全罩時不準作業。 	Chinese 警告
<ul style="list-style-type: none"> ● 얼굴로부터 용접가스를 멀리하십시오. ● 호흡지역으로부터 용접가스를 제거하기 위해 가스제거기나 통풍기를 사용하십시오. 	<ul style="list-style-type: none"> ● 보수전에 전원을 차단하십시오. 	<ul style="list-style-type: none"> ● 판넬이 열린 상태로 작동치 마십시오. 	Korean 위험
<ul style="list-style-type: none"> ● ابعد رأسك بعيداً عن الدخان. ● استعمل التهوية أو جهاز ضغط الدخان للخارج لكي تبعد الدخان عن المنطقة التي تتنفس فيها. 	<ul style="list-style-type: none"> ● اقطع التيار الكهربائي قبل القيام بأية صيانة. 	<ul style="list-style-type: none"> ● لا تشغيل هذا الجهاز إذا كانت الإغطية الحديدية الواقية ليست عليه. 	Arabic تحذير

LEIA E COMPREENDA AS INSTRUÇÕES DO FABRICANTE PARA ESTE EQUIPAMENTO E AS PARTES DE USO, E SIGA AS PRÁTICAS DE SEGURANÇA DO EMPREGADOR.

使う機械や溶材のメーカーの指示書をよく読み、まず理解して下さい。そして貴社の安全規定に従って下さい。

請詳細閱讀並理解製造廠提供的說明以及應該使用的銀焊材料，並請遵守貴方的有關勞動保護規定。

이 제품에 동봉된 작업지침서를 숙지하시고 귀사의 작업자 안전수칙을 준수하시기 바랍니다.

أقرأ بتمعن وأفهم تعليمات المصنع المنتج لهذه المعدات والمواد قبل استعمالها واتبع تعليمات الوقاية لمصاحب العمل.

IDEALARC® R3R 375-I, 500-I AND 600-I





• World's Leader in Welding and Cutting Products •

• Sales and Service through Subsidiaries and Distributors Worldwide •

Cleveland, Ohio 44117-1199 U.S.A. TEL: 216.481.8100 FAX: 216.486.1751 WEB SITE: www.lincolnelectric.com