

CLASSIC™ II

DC ARC WELDER WITH DEUTZ F3L-101 1F ENGINE

IM553-C

July, 2003

For use with machines having Code Numbers 10219, 10219CV, 10220, 10220CV, 10628, 10629, 10872 and 10910

Safety Depends on You

Lincoln arc welding and cutting equipment is designed and built with safety in mind. However, your overall safety can be increased by proper installation ... and thoughtful operation on your part. **DO NOT INSTALL, OPERATE OR REPAIR THIS EQUIPMENT WITHOUT READING THIS MANUAL AND THE SAFETY PRECAUTIONS CONTAINED THROUGHOUT.** And, most importantly, think before you act and be careful.

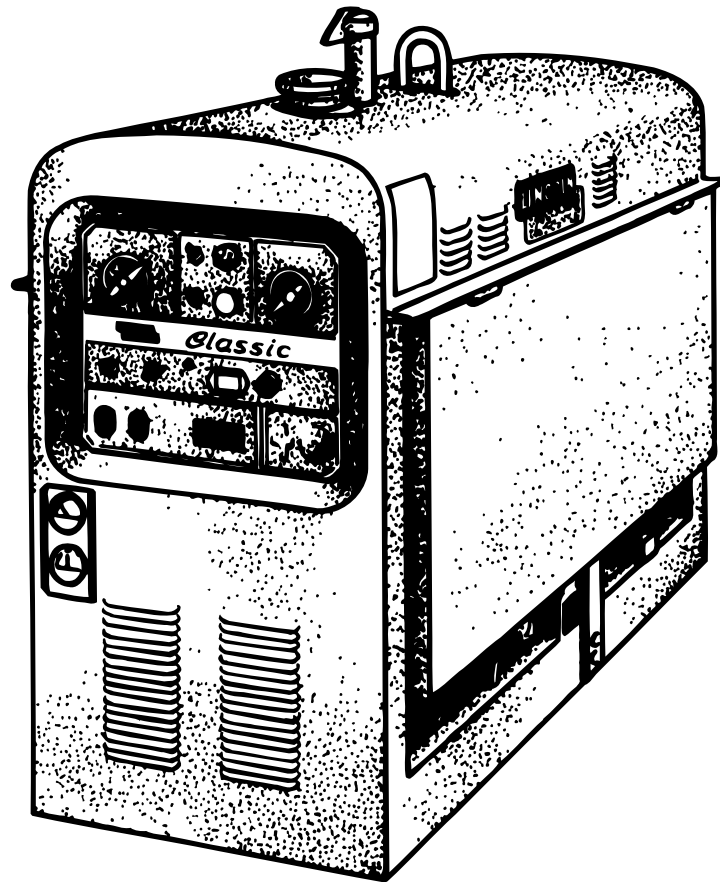

OPERATOR'S MANUAL



LINCOLN®
ELECTRIC

Copyright © 2003 Lincoln Global Inc.

- World's Leader in Welding and Cutting Products •
- Sales and Service through Subsidiaries and Distributors Worldwide •

Cleveland, Ohio 44117-1199 U.S.A. TEL: 216.481.8100 FAX: 216.486.1751 WEB SITE: www.lincolnelectric.com

⚠ WARNING

⚠ CALIFORNIA PROPOSITION 65 WARNINGS ⚠

Diesel engine exhaust and some of its constituents are known to the State of California to cause cancer, birth defects, and other reproductive harm.

The Above For Diesel Engines

The engine exhaust from this product contains chemicals known to the State of California to cause cancer, birth defects, or other reproductive harm.

The Above For Gasoline Engines

ARC WELDING CAN BE HAZARDOUS. PROTECT YOURSELF AND OTHERS FROM POSSIBLE SERIOUS INJURY OR DEATH. KEEP CHILDREN AWAY. PACEMAKER WEARERS SHOULD CONSULT WITH THEIR DOCTOR BEFORE OPERATING.

Read and understand the following safety highlights. For additional safety information, it is strongly recommended that you purchase a copy of "Safety in Welding & Cutting - ANSI Standard Z49.1" from the American Welding Society, P.O. Box 351040, Miami, Florida 33135 or CSA Standard W117.2-1974. A Free copy of "Arc Welding Safety" booklet E205 is available from the Lincoln Electric Company, 22801 St. Clair Avenue, Cleveland, Ohio 44117-1199.

BE SURE THAT ALL INSTALLATION, OPERATION, MAINTENANCE AND REPAIR PROCEDURES ARE PERFORMED ONLY BY QUALIFIED INDIVIDUALS.



FOR ENGINE powered equipment.

1.a. Turn the engine off before troubleshooting and maintenance work unless the maintenance work requires it to be running.



1.b. Operate engines in open, well-ventilated areas or vent the engine exhaust fumes outdoors.



1.c. Do not add the fuel near an open flame welding arc or when the engine is running. Stop the engine and allow it to cool before refueling to prevent spilled fuel from vaporizing on contact with hot engine parts and igniting. Do not spill fuel when filling tank. If fuel is spilled, wipe it up and do not start engine until fumes have been eliminated.

1.d. Keep all equipment safety guards, covers and devices in position and in good repair. Keep hands, hair, clothing and tools away from V-belts, gears, fans and all other moving parts when starting, operating or repairing equipment.

1.e. In some cases it may be necessary to remove safety guards to perform required maintenance. Remove guards only when necessary and replace them when the maintenance requiring their removal is complete. Always use the greatest care when working near moving parts.



1.f. Do not put your hands near the engine fan. Do not attempt to override the governor or idler by pushing on the throttle control rods while the engine is running.

1.g. To prevent accidentally starting gasoline engines while turning the engine or welding generator during maintenance work, disconnect the spark plug wires, distributor cap or magneto wire as appropriate.



1.h. To avoid scalding, do not remove the radiator pressure cap when the engine is hot.

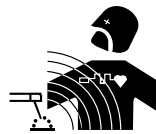

ELECTRIC AND MAGNETIC FIELDS may be dangerous

2.a. Electric current flowing through any conductor causes localized Electric and Magnetic Fields (EMF). Welding current creates EMF fields around welding cables and welding machines

2.b. EMF fields may interfere with some pacemakers, and welders having a pacemaker should consult their physician before welding.

2.c. Exposure to EMF fields in welding may have other health effects which are now not known.

2.d. All welders should use the following procedures in order to minimize exposure to EMF fields from the welding circuit:

2.d.1. Route the electrode and work cables together - Secure them with tape when possible.

2.d.2. Never coil the electrode lead around your body.

2.d.3. Do not place your body between the electrode and work cables. If the electrode cable is on your right side, the work cable should also be on your right side.

2.d.4. Connect the work cable to the workpiece as close as possible to the area being welded.

2.d.5. Do not work next to welding power source.

Mar '95

CLASSIC II DEUTZ





ELECTRIC SHOCK can kill.

- 3.a. The electrode and work (or ground) circuits are electrically "hot" when the welder is on. Do not touch these "hot" parts with your bare skin or wet clothing. Wear dry, hole-free gloves to insulate hands.
- 3.b. Insulate yourself from work and ground using dry insulation. Make certain the insulation is large enough to cover your full area of physical contact with work and ground.
- In addition to the normal safety precautions, if welding must be performed under electrically hazardous conditions (in damp locations or while wearing wet clothing; on metal structures such as floors, gratings or scaffolds; when in cramped positions such as sitting, kneeling or lying, if there is a high risk of unavoidable or accidental contact with the workpiece or ground) use the following equipment:**
- Semiautomatic DC Constant Voltage (Wire) Welder.
 - DC Manual (Stick) Welder.
 - AC Welder with Reduced Voltage Control.
- 3.c. In semiautomatic or automatic wire welding, the electrode, electrode reel, welding head, nozzle or semiautomatic welding gun are also electrically "hot".
- 3.d. Always be sure the work cable makes a good electrical connection with the metal being welded. The connection should be as close as possible to the area being welded.
- 3.e. Ground the work or metal to be welded to a good electrical (earth) ground.
- 3.f. Maintain the electrode holder, work clamp, welding cable and welding machine in good, safe operating condition. Replace damaged insulation.
- 3.g. Never dip the electrode in water for cooling.
- 3.h. Never simultaneously touch electrically "hot" parts of electrode holders connected to two welders because voltage between the two can be the total of the open circuit voltage of both welders.
- 3.i. When working above floor level, use a safety belt to protect yourself from a fall should you get a shock.
- 3.j. Also see Items 6.c. and 8.



ARC RAYS can burn.

- 4.a. Use a shield with the proper filter and cover plates to protect your eyes from sparks and the rays of the arc when welding or observing open arc welding. Headshield and filter lens should conform to ANSI Z87.1 standards.
- 4.b. Use suitable clothing made from durable flame-resistant material to protect your skin and that of your helpers from the arc rays.
- 4.c. Protect other nearby personnel with suitable, non-flammable screening and/or warn them not to watch the arc nor expose themselves to the arc rays or to hot spatter or metal.



FUMES AND GASES can be dangerous.

- 5.a. Welding may produce fumes and gases hazardous to health. Avoid breathing these fumes and gases. When welding, keep your head out of the fume. Use enough ventilation and/or exhaust at the arc to keep fumes and gases away from the breathing zone. **When welding with electrodes which require special ventilation such as stainless or hard facing (see instructions on container or MSDS) or on lead or cadmium plated steel and other metals or coatings which produce highly toxic fumes, keep exposure as low as possible and below Threshold Limit Values (TLV) using local exhaust or mechanical ventilation. In confined spaces or in some circumstances, outdoors, a respirator may be required. Additional precautions are also required when welding on galvanized steel.**
- 5.b. Do not weld in locations near chlorinated hydrocarbon vapors coming from degreasing, cleaning or spraying operations. The heat and rays of the arc can react with solvent vapors to form phosgene, a highly toxic gas, and other irritating products.
- 5.c. Shielding gases used for arc welding can displace air and cause injury or death. Always use enough ventilation, especially in confined areas, to insure breathing air is safe.
- 5.d. Read and understand the manufacturer's instructions for this equipment and the consumables to be used, including the material safety data sheet (MSDS) and follow your employer's safety practices. MSDS forms are available from your welding distributor or from the manufacturer.
- 5.e. Also see item 1.b.

Mar '95



WELDING SPARKS can cause fire or explosion.

6.a. Remove fire hazards from the welding area. If this is not possible, cover them to prevent the welding sparks from starting a fire.

Remember that welding sparks and hot materials from welding can easily go through small cracks and openings to adjacent areas. Avoid welding near hydraulic lines. Have a fire extinguisher readily available.

- 6.b. Where compressed gases are to be used at the job site, special precautions should be used to prevent hazardous situations. Refer to "Safety in Welding and Cutting" (ANSI Standard Z49.1) and the operating information for the equipment being used.
- 6.c. When not welding, make certain no part of the electrode circuit is touching the work or ground. Accidental contact can cause overheating and create a fire hazard.
- 6.d. Do not heat, cut or weld tanks, drums or containers until the proper steps have been taken to insure that such procedures will not cause flammable or toxic vapors from substances inside. They can cause an explosion even though they have been "cleaned". For information, purchase "Recommended Safe Practices for the Preparation for Welding and Cutting of Containers and Piping That Have Held Hazardous Substances", AWS F4.1 from the American Welding Society (see address above).
- 6.e. Vent hollow castings or containers before heating, cutting or welding. They may explode.
- 6.f. Sparks and spatter are thrown from the welding arc. Wear oil free protective garments such as leather gloves, heavy shirt, cuffless trousers, high shoes and a cap over your hair. Wear ear plugs when welding out of position or in confined places. Always wear safety glasses with side shields when in a welding area.
- 6.g. Connect the work cable to the work as close to the welding area as practical. Work cables connected to the building framework or other locations away from the welding area increase the possibility of the welding current passing through lifting chains, crane cables or other alternate circuits. This can create fire hazards or overheat lifting chains or cables until they fail.
- 6.h. Also see item 1.c.

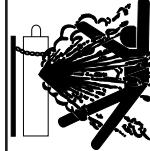

CYLINDER may explode if damaged.

7.a. Use only compressed gas cylinders containing the correct shielding gas for the process used and properly operating regulators designed for the gas and pressure used. All hoses, fittings, etc. should be suitable for the application and maintained in good condition.

- 7.b. Always keep cylinders in an upright position securely chained to an undercarriage or fixed support.
- 7.c. Cylinders should be located:
 - Away from areas where they may be struck or subjected to physical damage.
 - A safe distance from arc welding or cutting operations and any other source of heat, sparks, or flame.
- 7.d. Never allow the electrode, electrode holder or any other electrically "hot" parts to touch a cylinder.
- 7.e. Keep your head and face away from the cylinder valve outlet when opening the cylinder valve.
- 7.f. Valve protection caps should always be in place and hand tight except when the cylinder is in use or connected for use.
- 7.g. Read and follow the instructions on compressed gas cylinders, associated equipment, and CGA publication P-1, "Precautions for Safe Handling of Compressed Gases in Cylinders," available from the Compressed Gas Association 1235 Jefferson Davis Highway, Arlington, VA 22202.



FOR ELECTRICALLY powered equipment.

- 8.a. Turn off input power using the disconnect switch at the fuse box before working on the equipment.
- 8.b. Install equipment in accordance with the U.S. National Electrical Code, all local codes and the manufacturer's recommendations.
- 8.c. Ground the equipment in accordance with the U.S. National Electrical Code and the manufacturer's recommendations.

Mar '95

PRÉCAUTIONS DE SÛRETÉ

Pour votre propre protection lire et observer toutes les instructions et les précautions de sûreté spécifiques qui paraissent dans ce manuel aussi bien que les précautions de sûreté générales suivantes:

Sûreté Pour Soudage A L'Arc

1. Protégez-vous contre la secousse électrique:
 - a. Les circuits à l'électrode et à la pièce sont sous tension quand la machine à souder est en marche. Eviter toujours tout contact entre les parties sous tension et la peau nue ou les vêtements mouillés. Porter des gants secs et sans trous pour isoler les mains.
 - b. Faire très attention de bien s'isoler de la masse quand on soude dans des endroits humides, ou sur un plancher métallique ou des grilles métalliques, principalement dans les positions assis ou couché pour lesquelles une grande partie du corps peut être en contact avec la masse.
 - c. Maintenir le porte-électrode, la pince de masse, le câble de soudage et la machine à souder en bon et sûr état de fonctionnement.
 - d. Ne jamais plonger le porte-électrode dans l'eau pour le refroidir.
 - e. Ne jamais toucher simultanément les parties sous tension des porte-électrodes connectés à deux machines à souder parce que la tension entre les deux pinces peut être le total de la tension à vide des deux machines.
 - f. Si on utilise la machine à souder comme une source de courant pour soudage semi-automatique, ces précautions pour le porte-électrode s'appliquent aussi au pistolet de soudage.
2. Dans le cas de travail au dessus du niveau du sol, se protéger contre les chutes dans le cas où on reçoit un choc. Ne jamais enrouler le câble-électrode autour de n'importe quelle partie du corps.
3. Un coup d'arc peut être plus sévère qu'un coup de soleil, donc:
 - a. Utiliser un bon masque avec un verre filtrant approprié ainsi qu'un verre blanc afin de se protéger les yeux du rayonnement de l'arc et des projections quand on soude ou quand on regarde l'arc.
 - b. Porter des vêtements convenables afin de protéger la peau de soudeur et des aides contre le rayonnement de l'arc.
 - c. Protéger l'autre personnel travaillant à proximité au soudage à l'aide d'écrans appropriés et non-inflammables.
4. Des gouttes de laitier en fusion sont émises de l'arc de soudage. Se protéger avec des vêtements de protection libres de l'huile, tels que les gants en cuir, chemise épaisse, pantalons sans revers, et chaussures montantes.

5. Toujours porter des lunettes de sécurité dans la zone de soudage. Utiliser des lunettes avec écrans latéraux dans les zones où l'on pique le laitier.
6. Eloigner les matériaux inflammables ou les recouvrir afin de prévenir tout risque d'incendie dû aux étincelles.
7. Quand on ne soude pas, poser la pince à un endroit isolé de la masse. Un court-circuit accidentel peut provoquer un échauffement et un risque d'incendie.
8. S'assurer que la masse est connectée le plus près possible de la zone de travail qu'il est pratique de le faire. Si on place la masse sur la charpente de la construction ou d'autres endroits éloignés de la zone de travail, on augmente le risque de voir passer le courant de soudage par les chaînes de levage, câbles de grue, ou autres circuits. Cela peut provoquer des risques d'incendie ou d'échauffement des chaînes et des câbles jusqu'à ce qu'ils se rompent.
9. Assurer une ventilation suffisante dans la zone de soudage. Ceci est particulièrement important pour le soudage de tôles galvanisées plombées, ou cadmiées ou tout autre métal qui produit des fumées toxiques.
10. Ne pas souder en présence de vapeurs de chlore provenant d'opérations de dégraissage, nettoyage ou pistolage. La chaleur ou les rayons de l'arc peuvent réagir avec les vapeurs du solvant pour produire du phosgène (gas fortement toxique) ou autres produits irritants.
11. Pour obtenir de plus amples renseignements sur la sûreté, voir le code "Code for safety in welding and cutting" CSA Standard W 117.2-1974.

PRÉCAUTIONS DE SÛRETÉ POUR LES MACHINES À SOUDER À TRANSFORMATEUR ET À REDRESSEUR

1. Relier à la terre le chassis du poste conformément au code de l'électricité et aux recommandations du fabricant. Le dispositif de montage ou la pièce à souder doit être branché à une bonne mise à la terre.
2. Autant que possible, l'installation et l'entretien du poste seront effectués par un électricien qualifié.
3. Avant de faire des travaux à l'intérieur de poste, la débrancher à l'interrupteur à la boîte de fusibles.
4. Garder tous les couvercles et dispositifs de sûreté à leur place.

Mar. '93

CLASSIC II DEUTZ



Thank You

for selecting a **QUALITY** product by Lincoln Electric. We want you to take pride in operating this Lincoln Electric Company product
••• as much pride as we have in bringing this product to you!

Please Examine Carton and Equipment For Damage Immediately

When this equipment is shipped, title passes to the purchaser upon receipt by the carrier. Consequently, Claims for material damaged in shipment must be made by the purchaser against the transportation company at the time the shipment is received.

Please record your equipment identification information below for future reference. This information can be found on your machine nameplate.

Product _____

Model Number _____

Code Number or Date Code _____

Serial Number _____

Date Purchased _____

Where Purchased _____

Whenever you request replacement parts or information on this equipment, always supply the information you have recorded above. The code number is especially important when identifying the correct replacement parts.

On-Line Product Registration

- Register your machine with Lincoln Electric either via fax or over the Internet.
- For faxing: Complete the form on the back of the warranty statement included in the literature packet accompanying this machine and fax the form per the instructions printed on it.
- For On-Line Registration: Go to our **WEB SITE at www.lincolnelectric.com**. Choose "Quick Links" and then "Product Registration". Please complete the form and submit your registration.

Read this Operators Manual completely before attempting to use this equipment. Save this manual and keep it handy for quick reference. Pay particular attention to the safety instructions we have provided for your protection. The level of seriousness to be applied to each is explained below:

⚠ WARNING

This statement appears where the information **must** be followed **exactly** to avoid **serious personal injury or loss of life**.

⚠ CAUTION

This statement appears where the information **must** be followed to avoid **minor personal injury or damage to this equipment**.

TABLE OF CONTENTS

| | Page |
|--|-----------------------|
| Safety | i-iv |
| <hr/> | |
| Installation | Section A |
| Technical Specifications | A-1 |
| Safety Precautions..... | A-2 |
| Spark Arrester..... | A-2 |
| Location / Ventilation | A-2 |
| Grounding | A-2 |
| Lift Bail | A-2 |
| Undercarriages..... | A-2 |
| Polarity Control and Cable Sizes | A-3 |
| Pre-Operation Engine Service | A-3 |
| Oil..... | A-3 |
| Fuel | A-3 |
| Battery Charging | A-3 |
| Muffler | A-3 |
| <hr/> | |
| Operation | Section B |
| Safety Precautions..... | B-1 |
| General Description | B-1 |
| Starting and Stopping the Engine | B-1 |
| Cold Weather Starting | B-1 |
| Duty Cycle..... | B-1 |
| Control of Welding Current..... | B-1 |
| Idler | B-2 |
| Auxiliary Power Operation..... | B-2 |
| <hr/> | |
| Maintenance | Section D |
| General Instructions | D-1 |
| Cooling System | D-1 |
| Bearings | D-1 |
| Commutator and Brushes..... | D-2 |
| Idler Maintenance | D-2 |
| Nameplates | D-2 |
| <hr/> | |
| Troubleshooting | Section E |
| <hr/> | |
| Diagrams | Section F |
| <hr/> | |
| Parts List | P219, P78, P25 |
| <hr/> | |

TECHNICAL SPECIFICATIONS - CLASSIC II DEUTZ K1406-()

| INPUT - DIESEL ENGINE | | | | | |
|---|-------------------------------------|---|--------------------------------|---------------------------------------|--|
| Make/Model | Description | Speed (RPM) | Bore x Stroke | Starting System | Capacities |
| Deutz F3L 1011F Diesel Engine SA-250 | 3 cylinder 28.5 HP @ 1700 RPM | High Idle 1800 Low Idle 1350 Full Load 1725 | 3.58" x 4.13 (91mm x 105mm) | 12VDC battery & Starter | Fuel: 15gal. 57 L Oil: 6.3 Qts. 6.0 L |
| RATED OUTPUT - WELDER | | | | | |
| Duty Cycle | Constant Current | | | Volts at Rated Amps | |
| 40% | 300 amps (DC) | | | 32 volts | |
| 60% | 250 amps (DC) | | | 30 volts | |
| 100% | 200 amps (DC) | | | 28 volts | |
| OUTPUT - WELDER AND GENERATOR | | | | | |
| Current Range | | NEMA Output Rating | | Auxiliary Power | |
| 40-325 Amps | | 250 amps 30 volts @60% Duty Cycle | | 115/250 VAC 3kVA 60% Duty Cycle | |
| PHYSICAL DIMENSIONS | | | | | |
| HEIGHT | WIDTH | | DEPTH | | WEIGHT |
| 42.94 in. (1040 mm) | 24 in. (610 mm) | | 60 in. (1524 mm) | | 1340 lbs.(608 kg) |

CLASSIC II DEUTZ



SAFETY PRECAUTIONS

⚠ WARNING

Do not attempt to use this equipment until you have thoroughly read the engine manufacturer's manual supplied with your welder. It includes important safety precautions, detailed engine starting, operating and maintenance instructions, and parts lists.

**ELECTRIC SHOCK can kill.**

- Do not touch electrically live parts or electrode with skin or wet clothing.
- Insulate yourself from work and ground
- Always wear dry insulating gloves.

**ENGINE EXHAUST can kill.**

- Use in open, well ventilated areas or vent exhaust outside.

**MOVING PARTS can injure.**

- Do not operate with doors open or guards off.
- Stop engine before servicing.
- Keep away from moving parts.

See additional warning information at the front of this operator's manual.

Exhaust Spark Arrester

Some federal, state or local laws may require that diesel engines be equipped with exhaust spark arresters when they are operated in certain locations where unarrested sparks may present a fire hazard. The standard mufflers included with these welders do not qualify as spark arresters. When required by local regulations, install the optional spark arrester kit. Spark arresters must be installed and properly maintained, instructions are included in the kit.

⚠ CAUTION

Use of an incorrect arrester may lead to engine damage or performance loss.

Location/Ventilation

Always operate the welder with the doors closed. Leaving the doors open changes the designed air flow and may cause overheating.

The welder should be located to provide an unrestricted flow of clean, cool air. Also, locate the welder so that engine exhaust fumes are properly vented to an outside area.

⚠ CAUTION**DO NOT MOUNT OVER COMBUSTIBLE SURFACES.**

Where there is a combustible surface directly under stationary or fixed electrical equipment, the surface shall be covered with a steel plate at least .06"(1.6mm) thick, which shall extend not more than 5.90"(150mm) beyond the equipment on all sides.

Grounding

According to the United States National Electrical Code, the frame of this portable generator is not required to be grounded and is permitted to serve as the grounding means for cord connected equipment plugged into its receptacle.

Some state, local, or other codes or unusual operating circumstances may require the machine frame to be grounded. It is recommended that you determine the extent to which such requirements may apply to your particular situation and follow them explicitly. A machine grounding stud marked with the symbol  is provided on the welding generator frame foot. (If an older portable welder does not have a grounding stud, connect the ground wire to an unpainted frame screw or bolt.) In general, if the machine is to be grounded, it should be connected with a #8 or larger copper wire to a solid earth ground such as a metal water pipe going into the ground for at least ten feet and having no insulated joints, or to the metal framework of a building which has been effectively grounded. The U.S. National Electrical Code lists a number of alternate means of grounding electrical equipment.

Lift Bail

A lift bail is provided for lifting with a hoist.

⚠ WARNING

FALLING EQUIPMENT can cause injury.



- Do not lift this machine using lift bale if it is equipped with a heavy accessory such as a trailer or gas cylinder.
- Lift only with equipment of adequate

lifting capacity.

- Be sure machine is stable when lifting.

Undercarriages

If the user adapts a non-Lincoln undercarriage, he must assume responsibility that the method of attachment and usage does not result in a safety hazard nor damage the welding equipment. Some of the factors to be considered are as follows:

1. Design capacity of undercarriage vs. weight of Lincoln equipment and likely additional attachments.
2. Proper support of, and attachment to, the base of the welding equipment so there will be no undue stress to the framework.
3. Proper placement of the equipment on the undercarriage to ensure stability side to side and front to back when being moved and when standing by itself while being operated or serviced.
4. Typical conditions of use, i.e., travel speed, roughness of surface on which the undercarriage will be operated; environmental conditions, likely maintenance.
5. Conformance with federal, state and local laws. Consult applicable federal, state and local laws regarding specific requirements for use on public highways.

Polarity Control and Cable Sizes

With the engine off, route the electrode and work cables through the strain relief bracket on the base and connect to the studs located below the fuel tank mounting rail. (See size recommendations below.) For **positive** polarity, connect the electrode cable to the terminal marked “**Positive (+)**”. For **Negative** polarity, connect the electrode cable to the “**Negative (-)**” stud. These connections should be checked periodically and tightened if necessary.

When welding at a considerable distance from the

| RECOMMENDED COPPER CABLE SIZES | | | |
|--------------------------------|------------|---|----------------|
| Amps | Duty Cycle | Cables Sizes for Combined Length of Electrode Plus Work Cable | |
| | | Up to 200 ft. | 200 to 250 ft. |
| 200 | 100% | 1 | 1/0 |
| 250 | 60% | 1 | 1/0 |
| 300 | 40% | 1/0 | 2/0 |

welder, be sure you use ample size welding cables.

PRE-OPERATION SERVICE

READ the engine operating and maintenance instructions supplied with this machine.

Oil

This unit is supplied from the factory with the engine crankcase filled with a high quality SAE 10W/30 oil. This oil should be acceptable for most typical ambient temperatures. Consult the engine operation manual for specific engine manufacturer's recommendations. Upon receipt of the welder, check the engine dipstick to be sure the oil is at the “full” mark. DO NOT overfill.

Note: A optional Oil Drain Kit is available for this engine. (Order K1604-1)

NOTE: This unit is equipped with an Engine Protection Package, an internal kill switch will shut down the engine if the oil pressure drops below a minimum operating specification, or if the oil temperature reaches an excessive level.

Fuel

Fill the fuel tank with the grade of fuel recommended in the Engine Operator's manual. Make sure the fuel valve on the sediment bowl is in the open position.

Battery Charging

The Classic II is equipped with a wet charged battery. The charging current is automatically regulated when the battery is low (after starting the engine) to a trickle current when the battery is fully charged.

When replacing, jumping or otherwise connecting the battery to the battery cables, the proper polarity must be observed. This system is **NEGATIVE GROUND**.

WARNING

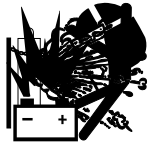

GASES FROM BATTERY can explode.

- Keep sparks, flame and cigarettes away.



BATTERY ACID can burn eyes and skin.

- Wear gloves and eye protection and be careful when boosting, charging or working near battery.

To prevent **EXPLOSION** when:

- Installing a new battery - disconnect the negative cable from the old battery first and connect the negative cable to the new battery last.
- Connecting a battery charger - remove the battery from the welder by disconnecting the negative cable first, then the positive cable and battery clamp. When reinstalling, connect the negative cable last.
- Using a booster - connect the positive lead to the battery first, then connect the negative lead to the ground lead on the base.

To prevent **ELECTRICAL DAMAGE** when:

- Installing a new battery.
- Using a booster.

Use correct polarity - **Negative Ground**.

To prevent BATTERY DISCHARGE, if you have an ignition switch, turn it off when engine is not running.

- To prevent BATTERY BUCKLING, tighten nuts on battery clamp until snug.

Muffler

This welder is supplied with an adjustable rain cap for the muffler. Install the rain cap using the clamp provided with the outlet facing away from the direction in which this unit will be transported. This will minimize the amount of water and debris which could enter the muffler during transportation.

SAFETY PRECAUTIONS

⚠ WARNING

Do not attempt to use this equipment until you have thoroughly read the engine manufacturer's manual supplied with your welder. It includes important safety precautions, detailed engine starting, operating and maintenance instructions, and parts lists.



ELECTRIC SHOCK can kill.

- Do not touch electrically live parts or electrode with skin or wet clothing.
- Insulate yourself from work and ground
- Always wear dry insulating gloves.



ENGINE EXHAUST can kill.

- Use in open, well ventilated areas or vent exhaust outside.



MOVING PARTS can injure.

- Do not operate with doors open or guards off.
- Stop engine before servicing.
- Keep away from moving parts.

See additional warning information at the front of this operator's manual.

GENERAL DESCRIPTION

The Classic™ II is a heavy duty engine driven DC arc welding power source capable of providing constant current output for stick welding or DC TIG welding. The Classic II is wound with all copper coils and is configured in a new shorter case with no exciter stick-out and setup for one side service. With the addition of the optional Wire Feed Module on models K1406-3 and K1406-4 the Classic II will provide constant voltage output for running the LN-7 or LN-25.

This unit uses the Deutz F3L-1011F industrial air cooled diesel engine.

Starting the Deutz F3L-1011F Engine

To start the engine, place the "IDLER" switch in the "HIGH" position, the "IGNITION" switch in the "ON" position and then press the "START" button. When the engine starts running, observe the oil pressure. If no pressure shows within 30 seconds, stop the engine and consult the engine operating manual. To stop the engine, place the "IGNITION" switch in the "OFF" position. If the engine protection warning light comes on during cranking or after start up, the "ignition" switch must be placed in the "OFF" position to reset the engine protection system.

When an engine is started for the first time, some of the oil will be needed to fill the passages of the lubricating system. Therefore, on initial starting, run the engine for about five minutes and then stop the engine and recheck the oil. If the level is down, fill to the full mark again. The engine controls were properly set at the factory and should require no adjusting when received.

At the end of each day's welding, drain accumulated dirt and water from the sediment bowl under the fuel tank and from the fuel filter per instructions in the engine manufacturer's operating manual. Refill the fuel tank to minimize moisture condensation in the tank. Also, running out of fuel tends to draw dirt into the fuel system. Check the crankcase oil level.

In diesel engines, if the fuel supply is cut off or runs out while the fuel pump is operating, air may be entrapped in the fuel distribution system. If this happens, bleeding of the fuel system should not be required since the Deutz F3L-1011F engine is equipped with a self priming feature.

Cold Weather Starting

Follow the instructions on the nameplate and in the engine manual shipped with the welder. With a fully charged battery and the proper weight oil, the engine should start satisfactorily even down to about 0°F.

If the engine must be frequently started below 10°F, it may be desirable to install the optional ether starter kit. Installation and operating instructions are included in the kit. Use ether starting only when required because excessive use shortens engine life.

It is important that the Engine Manufacturer's recommendations for oil and fuel are followed to obtain satisfactory cold weather performance. Consult the engine manual.

Duty Cycle

The NEMA output rating of the Classic II is 250 amperes at 30⁽¹⁾ arc volts on a 60% duty cycle (consult **SPECIFICATIONS** for alternate ratings). Duty cycle is based on a ten minute period; thus, the welder can be loaded at rated output for six minutes out of every ten minute period.

(1) The Lincoln "plus output" rating at 60% duty cycle is 250 amperes at 40 volts.

Control of Welding Current

⚠ CAUTION

DO NOT TURN THE "CURRENT RANGE SELECTOR" WHILE WELDING because the current may arc between the contacts and damage the switch.

The "Current Range Selector" provides five overlapping current ranges. The "Fine Current Adjustment" adjusts the current from minimum to maximum within each range. Open circuit voltage is also controlled by the "Fine Current Adjustment" permitting control of the arc characteristics.

CLASSIC II DEUTZ



A high open circuit voltage setting provides the soft “buttering” arc with best resistance to pop-outs preferred for most welding. To get this characteristic, set the “Current Range Selector” to the lowest setting that still provides the current you need and set the “Fine Current Adjustment” near maximum. For example: to obtain 175 amps and a soft arc, set the “Current Range Selector” to the 190-120 position and then adjust the “Fine Current Adjustment” for 175 amps.

When a forceful “digging” arc is required, usually for vertical and overhead welding, use a higher “Current Range Selector” setting and lower open circuit voltage. For example: to obtain 175 amps and a forceful arc, set the “Current Range Selector” to 240-160 position and the “Fine Current Adjustment” setting to get 175 amps.

Some arc instability may be experienced with EXX10 electrodes when trying to operate with long arc techniques at settings at the lower end of the open circuit voltage range.

CAUTION

DO NOT attempt to set the “Current Range Selector” between the five points designated on the nameplate. These switches have a spring loaded cam which almost eliminates the possibility of setting this switch between the designated points.

Idler Operation

Start the engine with the “Idler” switch in the “High” position. Allow it to run at high idle speed for several minutes to warm the engine. See **SPECIFICATIONS** for operating speeds.

The idler is controlled by the “Idler” toggle switch on the welder control panel. The switch has two positions as follows:

1. In the “High” position, the idler is off, and the engine high speed is controlled by the governor.
2. In the “Auto” position, the idler operates as follows:
 - a. When welding or drawing power for lights or tools (approximately 100-150 watts minimum) from the receptacles, the engine operates at full speed.
 - b. When welding ceases or the power load is turned off, a preset time delay of about 15 seconds starts. This time delay cannot be adjusted.
 - c. If the welding or power load is not re-started before the end of the time delay, the idler reduces the engine to low idle speed.

Auxiliary Power

The AC auxiliary power, supplied as a standard, has a rating of 3.0 kVA of 115/230V AC (60 hertz).

With the 3.0 kVA, 115/230V AC auxiliary power, one 115V duplex and one 230V grounding type receptacle are provided. The circuit is protected with circuit breakers.

The rating of 3.0 kVA permits a maximum continuous current of 13 amps to be drawn from the 230 volt duplex receptacle. Or a total of 26 amps can be drawn from the 115 volt duplex receptacle. The 115 volt duplex receptacle has a configuration which permits 15 amps on the K1406-3 & -5 and 20 amps on the K1406-4 & -6 to be drawn from either half. The total combined load of all receptacles is not to exceed 3.0 kVA.

An optional power plug kit is available. When this kit is specified, the customer is supplied with a plug for each receptacle.

An optional GFCI 115 volt receptacle kit is also available. Note that the use of this GFCI kit reduces available current to 15 Amps from each half of the duplex receptacle and to a total of 20 Amps of available 115 volt power.

SAFETY PRECAUTIONS

⚠ WARNING

Have qualified personnel do the maintenance work. Turn the engine off before working inside the machine. In some cases, it may be necessary to remove safety guards to perform required maintenance. Remove guards only when necessary and replace them when the maintenance requiring their removal is complete. Always use the greatest care when working near moving parts.

Do not put your hands near the engine cooling blower fan. If a problem cannot be corrected by following the instructions, take the machine to the nearest Lincoln Field Service Shop.



ELECTRIC SHOCK can kill.

- Do not touch electrically live parts or electrode with skin or wet clothing.
- Insulate yourself from work and ground
- Always wear dry insulating gloves.



ENGINE EXHAUST can kill.

- Use in open, well ventilated areas or vent exhaust outside.



MOVING PARTS can injure.

- Do not operate with doors open or guards off.
- Stop engine before servicing.
- Keep away from moving parts.

See additional warning information at the front of this operator's manual.

GENERAL INSTRUCTIONS

1. Blow out the welder and controls with an air hose at least once every two months. In particularly dirty locations, this cleaning may be necessary once a week. Use low pressure air to avoid driving dirt into the insulation.
2. "Current Range Selector" contacts should not be greased. To keep the contacts clean, rotate the current control through its entire range frequently. Good practice is to turn the handle from maximum to minimum setting twice each morning before starting to weld.
3. Change the crankcase oil and oil filter after the first 50 hours of operation and thereafter at 750 hour intervals using the proper grade of oil. See recommendations in the engine Operation Manual. Order Deutz oil filter #117-4416 or #117-4417 from

4. Inspect the air filter daily - more often in dusty conditions. When necessary, clean or replace. The filter should never be removed while the engine is running. The air filter element part number is Donaldson #181050 or Nelson #70206N.
5. Drain any accumulated water from the engine fuel filter/water separator daily. Change the filter every 1000 hours of operation. Order Deutz fuel filter #117-4482 from your local Deutz Service Center. A fuel filter element without the water separator may be used in place of the standard element. Order Deutz #117-4696.
6. Fan belts tend to loosen after the first 50 hours of operation. Check engine Operation Manual and tighten if necessary. **DO NOT OVER TIGHTEN.**
7. Put a drop of oil on the "Current Range Selector" shaft at least once every month.
8. See the engine manufacturer's Operation Manual for detailed engine maintenance and troubleshooting instructions.

COOLING SYSTEM

The Classic II is equipped with an air cooled Deutz engine. Clean the engine cooling system periodically to prevent clogging the air passages on the cylinder heads and oil cooler and overheating the engine. Consult the **Engine Operation Manual**. It is important that the welder is located in a manner which will provide an unrestricted flow of clean, cool air.

BEARINGS

This welder is equipped with a double-shielded ball bearing having sufficient grease to last indefinitely under normal service. Where the welder is used constantly or in excessively dirty locations, it may be necessary to add one half ounce of grease per year. A pad of grease one inch wide, one inch long, and one inch high weighs approximately one half ounce. Over-greasing is far worse than insufficient greasing.

When greasing the bearings, keep all dirt out of the area. Wipe the fittings completely clean and use clean equipment. More bearing failures are caused by dirt introduced during greasing than from insufficient grease.

Commutator and Brushes

The generator brushes are properly adjusted when the welder is shipped. They require no particular attention. **DO NOT SHIFT THE BRUSHES** or adjust the rocker setting.

Shifting of the brushes may result in:

- change in machine output
- commutator damage
- excessive brush wear

Periodically inspect the commutator, slip rings, and brushes by removing the covers. **DO NOT** remove or replace these covers while the machine is running.

Commutators and slip rings require little attention. However, if they are black or appear uneven, have them cleaned by an experienced maintenance man using fine sandpaper or a commutator stone. Never use emery cloth or paper for this purpose.

NOTE: If the welder is used in dirty or dusty locations, or if the welder is not used for prolonged periods of time, it may be necessary to clean the commutator and slip rings more often.

Replace brushes when they wear within 1/4" of the pigtail. A complete set of replacement brushes should be kept on hand. Lincoln brushes have a curved face to fit the commutator. Have an experienced maintenance man seat these brushes by lightly stoning the commutator as the armature rotates at full speed until contact is made across the full face of the brushes. After stoning, blow out the dust with low pressure air.

To seat slip ring brushes, position the brushes in place. Then slide one end of a piece of fine sandpaper between slip rings and brushes with the coarse side against the brushes. With slight additional finger pressure on top of the brushes, pull the sandpaper around the circumference of the rings - in direction of rotation only - until brushes seat properly. In addition, stone slip ring with a fine stone. Brushes must be

WARNING

seated 100%.

Uncovered rotating equipment can be dangerous. Use care so your hands, hair, clothing or tools do not catch in the rotating parts. Protect yourself from particles that may be thrown out by the rotating armature when stoning the commutator.

Arcing or excessive exciter brush wear indicates a possible misaligned shaft. Have an authorized Field Service Shop check and realign the shaft.

Idler Maintenance

1. The solenoid plunger must work freely and not bind. Dust the plunger about once a year with graphite powder.
2. Proper operation of the idler requires good grounding of the printed circuit board, reed switch, and battery.
3. If desired, the welder can be used without automatic idling by setting the "Idler" switch to the "High" position.

CAUTION

Before doing electrical work on the idler printed circuit board, disconnect the battery. When installing a new battery or using a jumper battery to start the engine, be sure the battery polarity is connected properly. The correct polarity is negative ground. Damage to the engine alternator and the printed circuit board can result from incorrect connection.

Nameplates

Whenever routine maintenance is performed on this machine - or at least yearly - inspect all nameplates and labels for legibility. Replace those which are no longer clear. Refer to the parts list for the replacement item number.

HOW TO USE TROUBLESHOOTING GUIDE

⚠ WARNING

Service and Repair should only be performed by Lincoln Electric Factory Trained Personnel. Unauthorized repairs performed on this equipment may result in danger to the technician and machine operator and will invalidate your factory warranty. For your safety and to avoid Electrical Shock, please observe all safety notes and precautions detailed throughout this manual.

This Troubleshooting Guide is provided to help you locate and repair possible machine malfunctions. Simply follow the three-step procedure listed below.

Step 1. LOCATE PROBLEM (SYMPTOM).

Look under the column labeled "PROBLEM (SYMPTOMS)". This column describes possible symptoms that the machine may exhibit. Find the listing that best describes the symptom that the machine is exhibiting.

Step 2. POSSIBLE CAUSE.

The second column labeled "POSSIBLE CAUSE" lists the obvious external possibilities that may contribute to the machine symptom.

Step 3. RECOMMENDED COURSE OF ACTION

This column provides a course of action for the Possible Cause, generally it states to contact your local Lincoln Authorized Field Service Facility.

If you do not understand or are unable to perform the Recommended Course of Action safely, contact your local Lincoln Authorized Field Service Facility.



ELECTRIC SHOCK can kill.

- Do not touch electrically live parts or electrode with skin or wet clothing.
- Insulate yourself from work and ground
- Always wear dry insulating gloves.



ENGINE EXHAUST can kill.

- Use in open, well ventilated areas or vent exhaust outside.



MOVING PARTS can injure.

- Do not operate with doors open or guards off.
- Stop engine before servicing.
- Keep away from moving parts.

See additional warning information at the front of this operator's manual

⚠ CAUTION

If for any reason you do not understand the test procedures or are unable to perform the tests/repairs safely, contact your **Local Lincoln Authorized Field Service Facility** for technical troubleshooting assistance before you proceed.

CLASSIC II DEUTZ



Observe all Safety Guidelines detailed throughout this manual

| PROBLEMS (SYMPTOMS) | POSSIBLE AREAS OF MISADJUSTMENT(S) | RECOMMENDED COURSE OF ACTION |
|--|---|---|
| PROBLEMS | | |
| Machine fails to hold the "heat" constantly. | a. Rough or dirty commutator. b. Brushes may be worn down to limit. c. Field circuit may have variable resistance connection or intermittent open circuit due to loose connection or broken wire. d. Electrode lead or work lead connection may be poor. e. Wrong grade of brushes may have been installed on generator. f. Field rheostat may be making poor contact and overheating. | Contact your Local Lincoln Authorized Field Service Facility for technical troubleshooting assistance. |
| Welder starts but fails to generate current. | a. Generator or exciter brushes may be loose or missing. b. Exciter may not be operating. c. Field circuit of generator or exciter may be open. d. Exciter may have lost excitation. Flash Fields ⁽¹⁾ e. Series field and armature circuit may be open-circuited. | |

(1) FLASHING THE FIELDS:

1. Stop the engine welder and remove the cover from the exciter.
2. Turn the "Fine Adjustment Control" (rheostat) to "100" on the dial.
3. Using a 12 volt automotive battery, connect its negative terminal to the negative brush holder. The negative brush holder is the one nearest to the rotor lamination. See the wiring diagram. With the engine **NOT** running, touch the positive battery terminal to the positive brush holder. Remove the battery from the circuit.
4. Replace the exciter cover. Start the welder and the generator voltage should build up.

CAUTION

If for any reason you do not understand the test procedures or are unable to perform the tests/repairs safely, contact your **Local Lincoln Authorized Field Service Facility** for technical troubleshooting assistance before you proceed.

CLASSIC II DEUTZ



Observe all Safety Guidelines detailed throughout this manual

| PROBLEMS (SYMPTOMS) | POSSIBLE AREAS OF MISADJUSTMENT(S) | RECOMMENDED COURSE OF ACTION |
|--|--|---|
| PROBLEMS | | |
| Welding arc is loud and spatters excessively. | <ul style="list-style-type: none"> a. Current setting may be too high. b. Polarity may be wrong. | Contact your Local Lincoln Authorized Field Service Facility for technical troubleshooting assistance. |
| Welding current too great or too small compared to indication on the dial. | <ul style="list-style-type: none"> a. Exciter output low causing low output compared to dial indication. b. Operating speed too low or high. | |
| Engine shuts down and engine protection light comes on. | <ul style="list-style-type: none"> a. Low oil pressure. b. High oil temperature. c. Broken fan belt. d. Battery charging alternator is not operating. e. Fuel solenoid coil shorted | |
| | | |

 **CAUTION**

If for any reason you do not understand the test procedures or are unable to perform the tests/repairs safely, contact your **Local Lincoln Authorized Field Service Facility** for technical troubleshooting assistance before you proceed.

CLASSIC II DEUTZ



ELECTRONIC IDLER TROUBLESHOOTING GUIDE

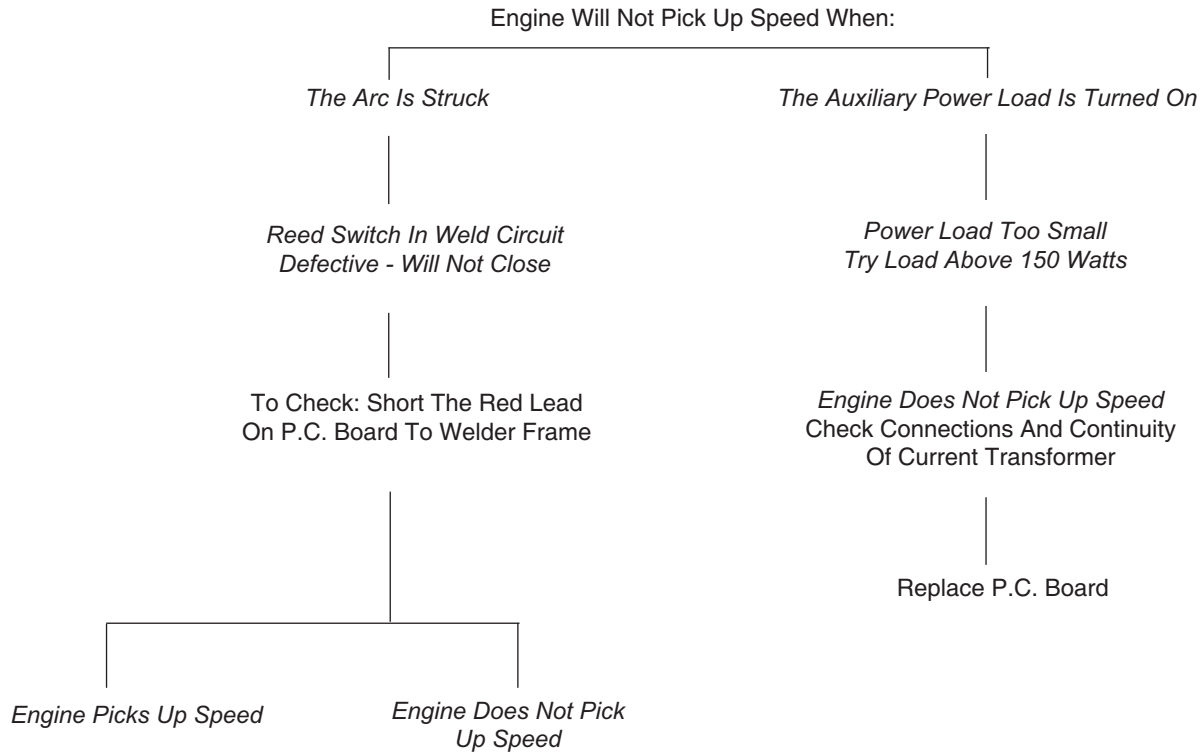
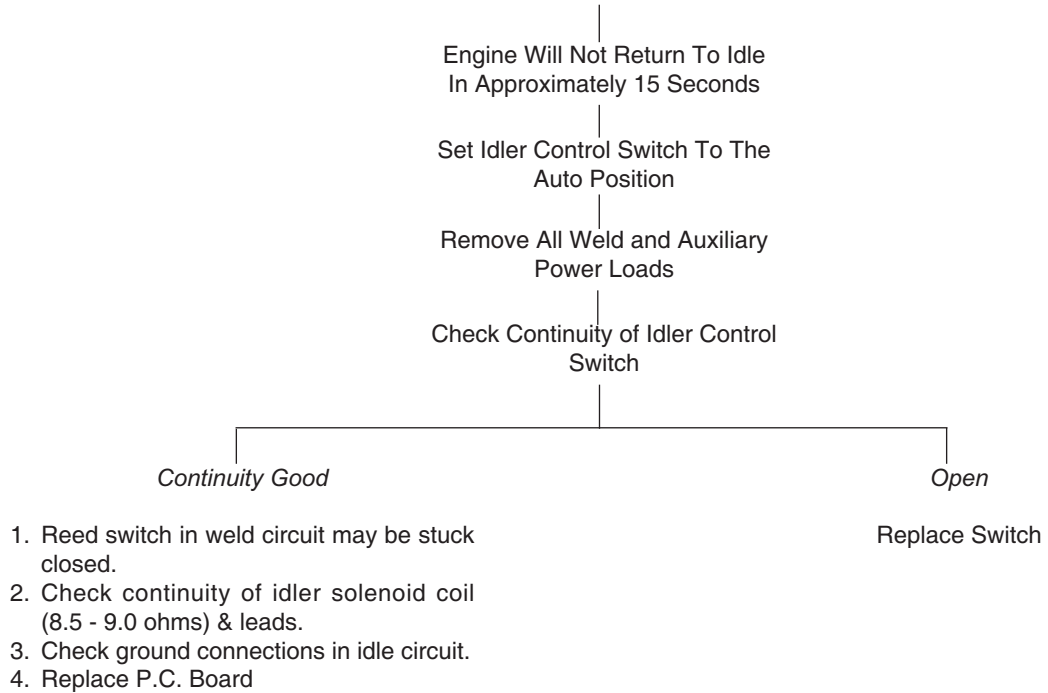

1. Check for break in Red lead and repair.
2. Replace reed switch in weld circuit.

WIRING DIAGRAM - CODE 10628 & 10629

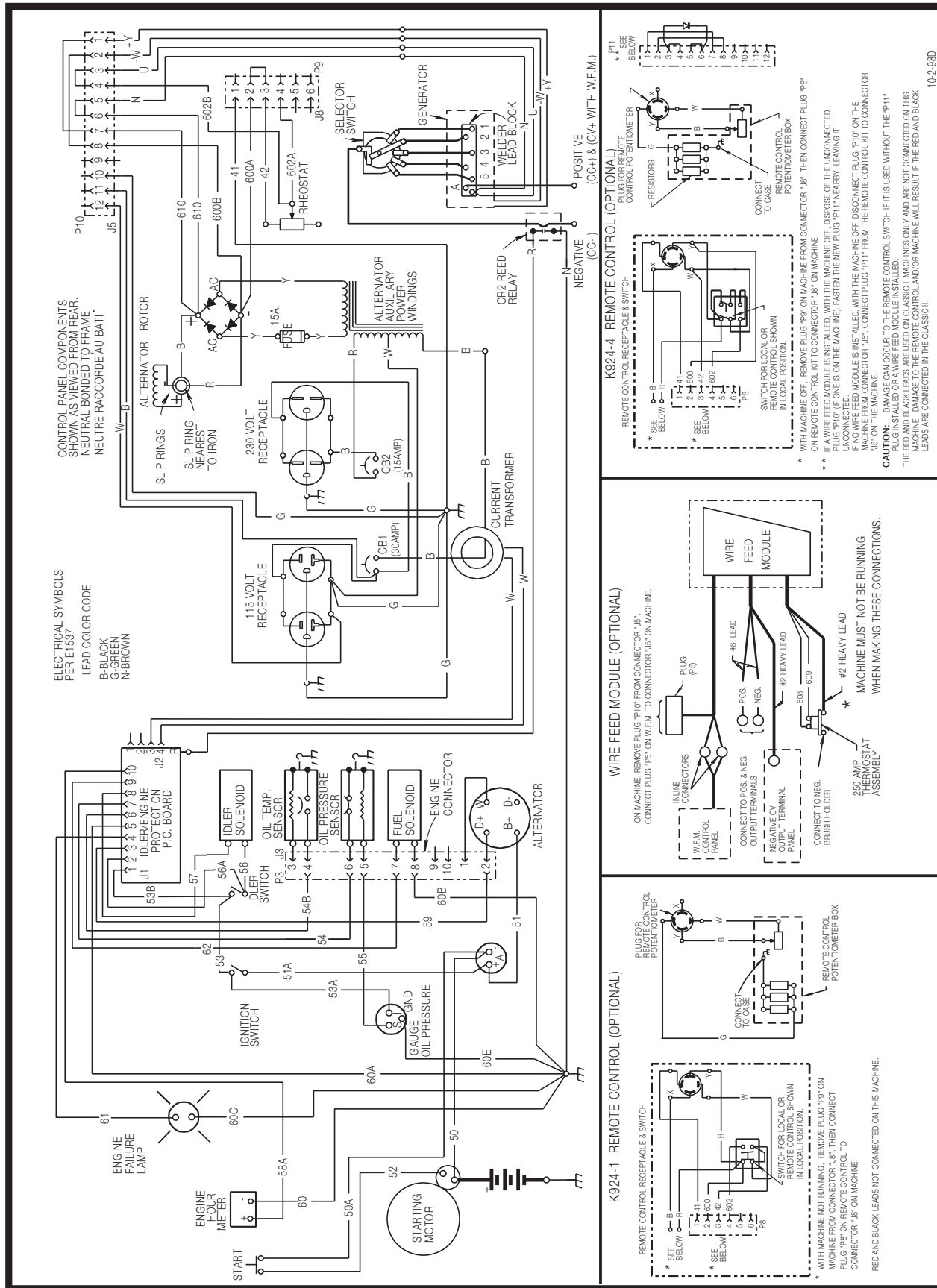

NOTE: This diagram is for reference only. It may not be accurate for all machines covered by this manual. The specific diagram for a particular code is pasted inside the machine on one of the enclosure panels. If the diagram is illegible, write to the Service Department for a replacement. Give the equipment code number..

WIRING DIAGRAM - CODE 10219 & 10219CV

CLASSIC II - WIRING DIAGRAM

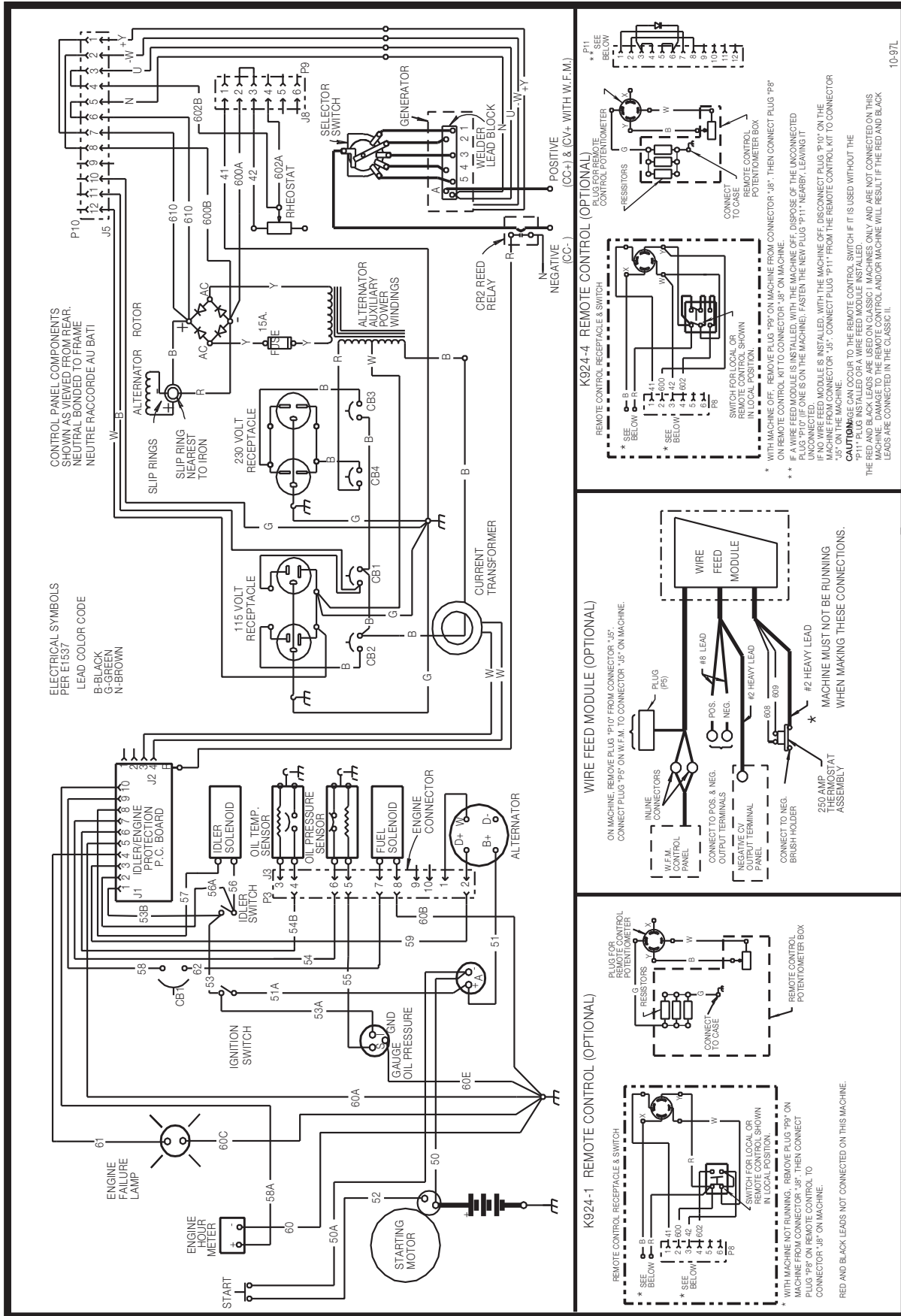

L9920

NOTE: This diagram is for reference only. It may not be accurate for all machines covered by this manual. The specific diagram for a particular code is pasted inside the machine on one of the enclosure panels. If the diagram is illegible, write to the Service Department for a replacement. Give the equipment code number.

WIRING DIAGRAM - CODE 10220 & 10220CV

CLASSIC II - WIRING DIAGRAM

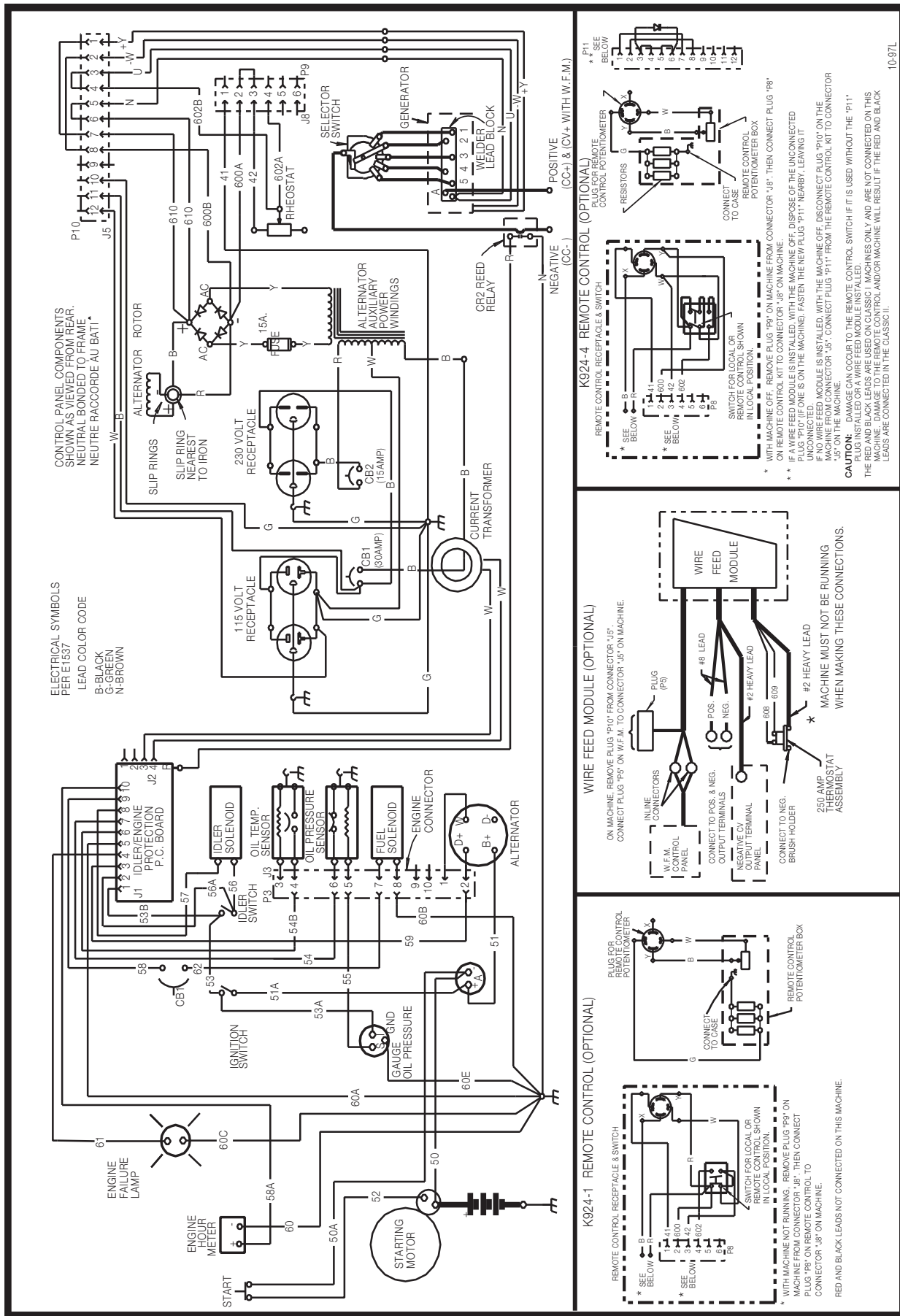

L9919

NOTE: This diagram is for reference only. It may not be accurate for all machines covered by this manual. The specific diagram for a particular code is pasted inside the machine on one of the enclosure panels. If the diagram is illegible, write to the Service Department for a replacement. Give the equipment code number.

WIRING DIAGRAM - CODE 10910

CLASSIC II - WIRING DIAGRAM

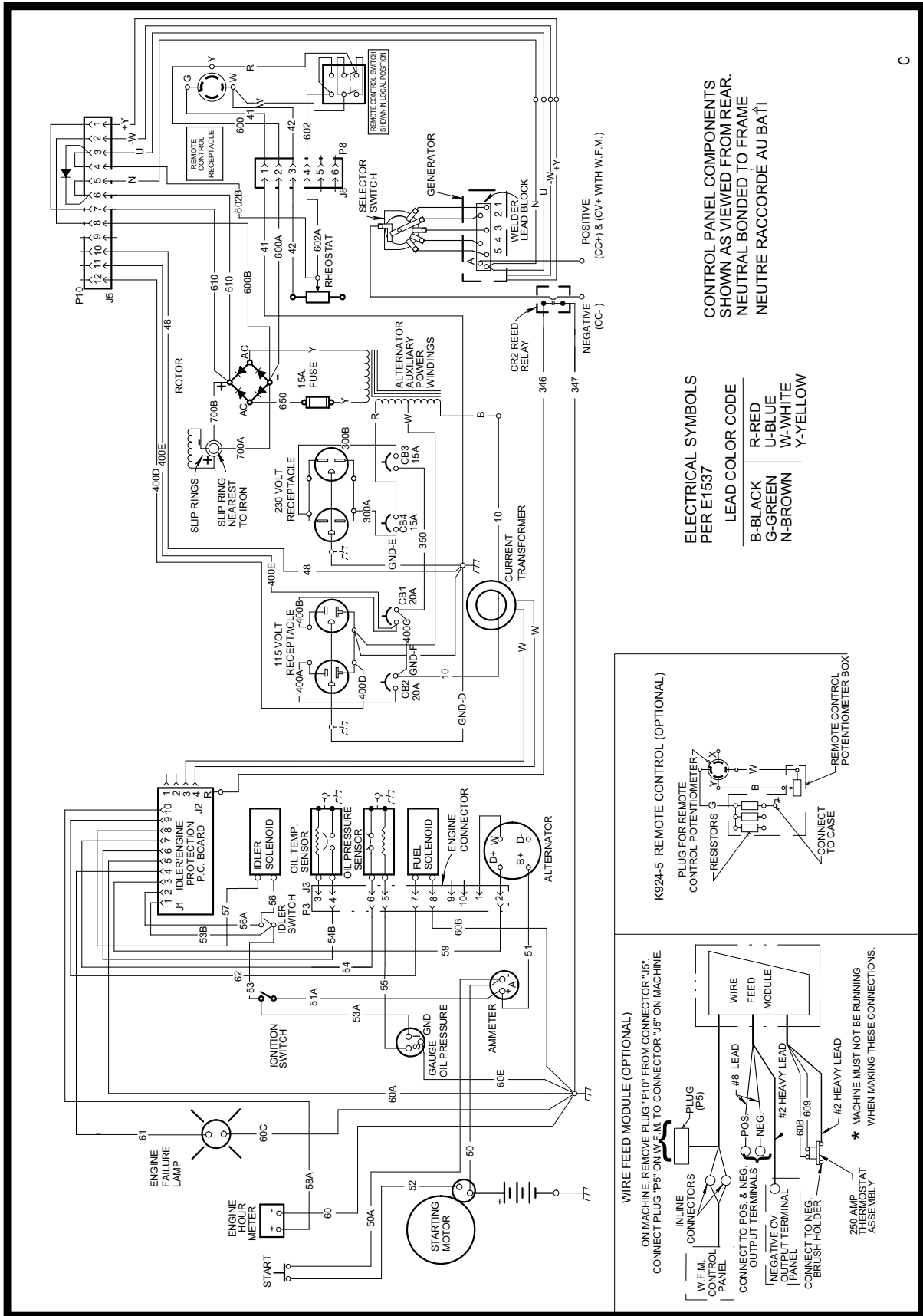

ELECTRICAL SYMBOLS PER E1537

| LEAD COLOR CODE | R-RED | U-BLUE | W-WHITE | Y-YELLOW |
|-----------------|-------|--------|---------|----------|
| B-BLACK | | | | |
| G-GREEN | | | | |
| N-BROWN | | | | |

CONTROL PANEL COMPONENTS SHOWN AS VIEWED FROM REAR.
NEUTRAL BONDED TO FRAME
NEUTRE RACCORDE AU BATI

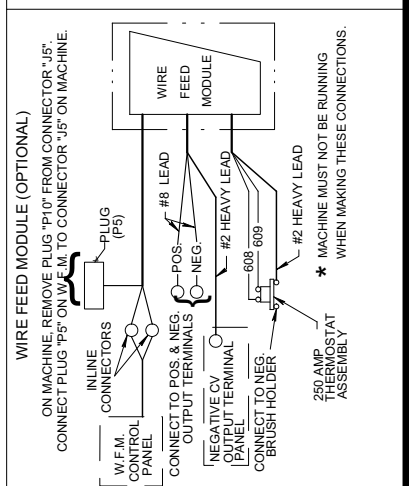
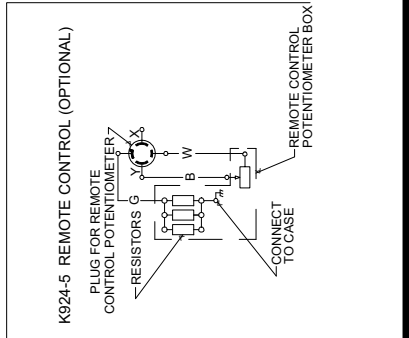

C

L11863

NOTE: This diagram is for reference only. It may not be accurate for all machines covered by this manual. The specific diagram for a particular code is pasted inside the machine on one of the enclosure panels. If the diagram is illegible, write to the Service Department for a replacement. Give the equipment code number..

DIMENSION PRINT

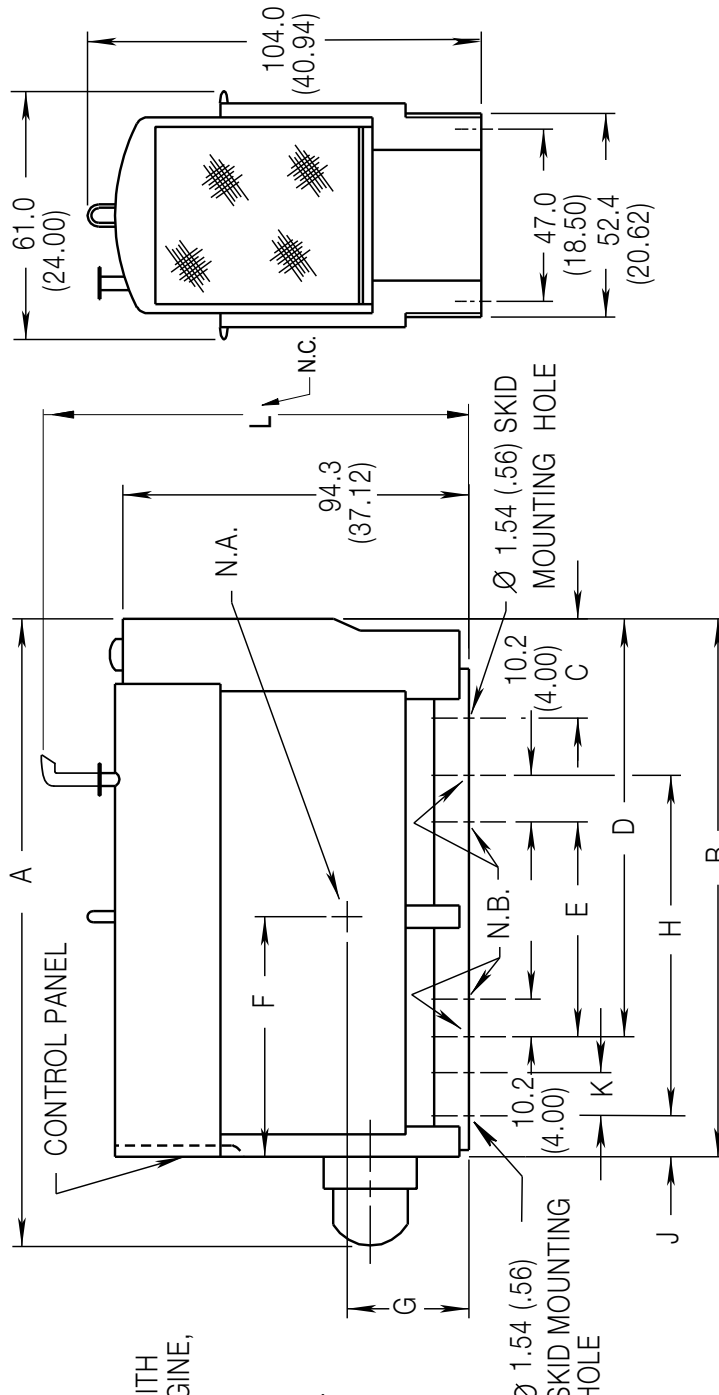

- NOTES:
 N.A. CENTER OF GRAVITY WITH OIL AND WATER IN ENGINE, BUT NO FUEL.
 N.B. Ø 1.54 (.56) TRAILER MOUNTING HOLES.
 N.C. DIMENSION TO TOP OF EXHAUST ELBOW OR RAINCAP.

METRIC cm (ENGLISH in.)

| | | | | | | | | | | | | |
|----------|------------|------------------|---------------|-----------------|-----------------|-----------------|------------------|----------------|----------------|-----------------|---|---|
| S10766-6 | CLASSIC II | 150.7 (59.32) | 4.8 (1.90) | 58.4 (23.00) | 79.2 (31.19) | 43.8 (17.25) | 105.8 (41.66) | 19.1 (7.51) | 16.5 (6.50) | 106.7 (42.0) | | |
| PART NO. | WELDER | A | B | C | D | E | F | G | H | J | K | L |

02 / 26 / 03

S10766



NOTES

CLASSIC II DEUTZ



| | | | |
|---------------------------------------|---|---|---|
| | | | |
| WARNING | <ul style="list-style-type: none"> ● Do not touch electrically live parts or electrode with skin or wet clothing. ● Insulate yourself from work and ground. | <ul style="list-style-type: none"> ● Keep flammable materials away. | <ul style="list-style-type: none"> ● Wear eye, ear and body protection. |
| Spanish AVISO DE PRECAUCION | <ul style="list-style-type: none"> ● No toque las partes o los electrodos bajo carga con la piel o ropa mojada. ● Aíslese del trabajo y de la tierra. | <ul style="list-style-type: none"> ● Mantenga el material combustible fuera del área de trabajo. | <ul style="list-style-type: none"> ● Protéjase los ojos, los oídos y el cuerpo. |
| French ATTENTION | <ul style="list-style-type: none"> ● Ne laissez ni la peau ni des vêtements mouillés entrer en contact avec des pièces sous tension. ● Isolez-vous du travail et de la terre. | <ul style="list-style-type: none"> ● Gardez à l'écart de tout matériel inflammable. | <ul style="list-style-type: none"> ● Protégez vos yeux, vos oreilles et votre corps. |
| German WARNUNG | <ul style="list-style-type: none"> ● Berühren Sie keine stromführenden Teile oder Elektroden mit Ihrem Körper oder feuchter Kleidung! ● Isolieren Sie sich von den Elektroden und dem Erdboden! | <ul style="list-style-type: none"> ● Entfernen Sie brennbares Material! | <ul style="list-style-type: none"> ● Tragen Sie Augen-, Ohren- und Körperschutz! |
| Portuguese ATENÇÃO | <ul style="list-style-type: none"> ● Não toque partes elétricas e electrodos com a pele ou roupa molhada. ● Isole-se da peça e terra. | <ul style="list-style-type: none"> ● Mantenha inflamáveis bem guardados. | <ul style="list-style-type: none"> ● Use proteção para a vista, ouvido e corpo. |
| Japanese 注意事項 | <ul style="list-style-type: none"> ● 通電中の電気部品、又は溶材にヒフやぬれた布で触れないこと。 ● 施工物やアースから身体が絶縁されている様にして下さい。 | <ul style="list-style-type: none"> ● 燃えやすいものの側での溶接作業は絶対にしてはなりません。 | <ul style="list-style-type: none"> ● 目、耳及び身体に保護具をして下さい。 |
| Chinese 警告 | <ul style="list-style-type: none"> ● 皮膚或濕衣物切勿接觸帶電部件及鎢條。 ● 使你自己與地面和工件絕緣。 | <ul style="list-style-type: none"> ● 把一切易燃物品移離工作場所。 | <ul style="list-style-type: none"> ● 佩戴眼、耳及身體勞動保護用具。 |
| Korean 위험 | <ul style="list-style-type: none"> ● 전도체나 용접봉을 젖은 형갑 또는 피부로 절대 접촉치 마십시오. ● 모재와 접지를 접촉치 마십시오. | <ul style="list-style-type: none"> ● 인화성 물질을 접근시키지 마십시오. | <ul style="list-style-type: none"> ● 눈, 귀와 몸에 보호장구를 착용하십시오. |
| Arabi تحذير | <ul style="list-style-type: none"> ● لا تلمس الاجزاء التي يسري فيها التيار الكهربائي أو الألكترود بجسد الجسم أو بالملابس المبللة بالماء. ● ضع عازلا على جسمك خلال العمل. | <ul style="list-style-type: none"> ● ضع المواد القابلة للاشتعال في مكان بعيد. | <ul style="list-style-type: none"> ● ضع أدوات وملابس واقية على عينيك وأذنيك وجسمك. |

READ AND UNDERSTAND THE MANUFACTURER'S INSTRUCTION FOR THIS EQUIPMENT AND THE CONSUMABLES TO BE USED AND FOLLOW YOUR EMPLOYER'S SAFETY PRACTICES.

SE RECOMIENDA LEER Y ENTENDER LAS INSTRUCCIONES DEL FABRICANTE PARA EL USO DE ESTE EQUIPO Y LOS CONSUMIBLES QUE VA A UTILIZAR, SIGA LAS MEDIDAS DE SEGURIDAD DE SU SUPERVISOR.

LISEZ ET COMPRENEZ LES INSTRUCTIONS DU FABRICANT EN CE QUI REGARDE CET EQUIPMENT ET LES PRODUITS A ETRE EMPLOYES ET SUIVEZ LES PROCEDURES DE SECURITE DE VOTRE EMPLOYEUR.

LESEN SIE UND BEFOLGEN SIE DIE BETRIEBSANLEITUNG DER ANLAGE UND DEN ELEKTRODENEINSATZ DES HERSTELLERS. DIE UNFALLVERHÜTUNGSVORSCHRIFTEN DES ARBEITGEBERS SIND EBENFALLS ZU BEACHTEN.

| | | | |
|---|--|---|--|
|  |  |  |  |
| <ul style="list-style-type: none"> ● Keep your head out of fumes. ● Use ventilation or exhaust to remove fumes from breathing zone. | <ul style="list-style-type: none"> ● Turn power off before servicing. | <ul style="list-style-type: none"> ● Do not operate with panel open or guards off. | WARNING |
| <ul style="list-style-type: none"> ● Los humos fuera de la zona de respiración. ● Mantenga la cabeza fuera de los humos. Utilice ventilación o aspiración para gases. | <ul style="list-style-type: none"> ● Desconectar el cable de alimentación de poder de la máquina antes de iniciar cualquier servicio. | <ul style="list-style-type: none"> ● No operar con panel abierto o guardas quitadas. | Spanish AVISO DE PRECAUCION |
| <ul style="list-style-type: none"> ● Gardez la tête à l'écart des fumées. ● Utilisez un ventilateur ou un aspirateur pour ôter les fumées des zones de travail. | <ul style="list-style-type: none"> ● Débranchez le courant avant l'entretien. | <ul style="list-style-type: none"> ● N'opérez pas avec les panneaux ouverts ou avec les dispositifs de protection enlevés. | French ATTENTION |
| <ul style="list-style-type: none"> ● Vermeiden Sie das Einatmen von Schweißrauch! ● Sorgen Sie für gute Be- und Entlüftung des Arbeitsplatzes! | <ul style="list-style-type: none"> ● Strom vor Wartungsarbeiten abschalten! (Netzstrom völlig öffnen; Maschine anhalten!) | <ul style="list-style-type: none"> ● Anlage nie ohne Schutzgehäuse oder Innenschutzverkleidung in Betrieb setzen! | German WARNUNG |
| <ul style="list-style-type: none"> ● Mantenha seu rosto da fumaça. ● Use ventilação e exaustão para remover fumo da zona respiratória. | <ul style="list-style-type: none"> ● Não opere com as tampas removidas. ● Desligue a corrente antes de fazer serviço. ● Não toque as partes elétricas nuas. | <ul style="list-style-type: none"> ● Mantenha-se afastado das partes moventes. ● Não opere com os painéis abertos ou guardas removidas. | Portuguese ATENÇÃO |
| <ul style="list-style-type: none"> ● ヒュームから頭を離すようにして下さい。 ● 換気や排煙に十分留意して下さい。 | <ul style="list-style-type: none"> ● メンテナンス・サービスに取りかかる際には、まず電源スイッチを必ず切ってください。 | <ul style="list-style-type: none"> ● パネルやカバーを取り外したまま機械操作をしないで下さい。 | Japanese 注意事項 |
| <ul style="list-style-type: none"> ● 頭部遠離煙霧。 ● 在呼吸區使用通風或排風器除煙。 | <ul style="list-style-type: none"> ● 維修前切斷電源。 | <ul style="list-style-type: none"> ● 儀表板打開或沒有安全罩時不準作業。 | Chinese 警告 |
| <ul style="list-style-type: none"> ● 얼굴로부터 용접가스를 멀리하십시오. ● 호흡지역으로부터 용접가스를 제거하기 위해 가스제거기나 통풍기를 사용하십시오. | <ul style="list-style-type: none"> ● 보수전에 전원을 차단하십시오. | <ul style="list-style-type: none"> ● 판넬이 열린 상태로 작동치 마십시오. | Korean 위험 |
| <ul style="list-style-type: none"> ● ابتعد رأسك بعيداً عن الدخان. ● استعمل التهوية أو جهاز ضغط الدخان للخارج لكي تبعد الدخان عن المنطقة التي تتنفس فيها. | <ul style="list-style-type: none"> ● أقطع التيار الكهربائي قبل القيام بأية صيانة. | <ul style="list-style-type: none"> ● لا تشغيل هذا الجهاز اذا كانت الاغطية الحديدية الواقية ليست عليه. | Arabic تحذير |

LEIA E COMPREENDA AS INSTRUÇÕES DO FABRICANTE PARA ESTE EQUIPAMENTO E AS PARTES DE USO, E SIGA AS PRÁTICAS DE SEGURANÇA DO EMPREGADOR.

使う機械や溶材のメーカーの指示書をよく読み、まず理解して下さい。そして貴社の安全規定に従って下さい。

請詳細閱讀並理解製造廠提供的說明以及應該使用的銀焊材料，並請遵守貴方的有閣勞動保護規定。

이 제품에 동봉된 작업지침서를 숙지하시고 귀사의 작업자 안전수칙을 준수하시기 바랍니다.

اقرأ بتمعن وافهم تعليمات المصنع المنتج لهذه المعدات والمواد قبل استعمالها واتبع تعليمات الوقاية لصاحب العمل.



• World's Leader in Welding and Cutting Products •

• Sales and Service through Subsidiaries and Distributors Worldwide •

Cleveland, Ohio 44117-1199 U.S.A. TEL: 216.481.8100 FAX: 216.486.1751 WEB SITE: www.lincolnelectric.com