

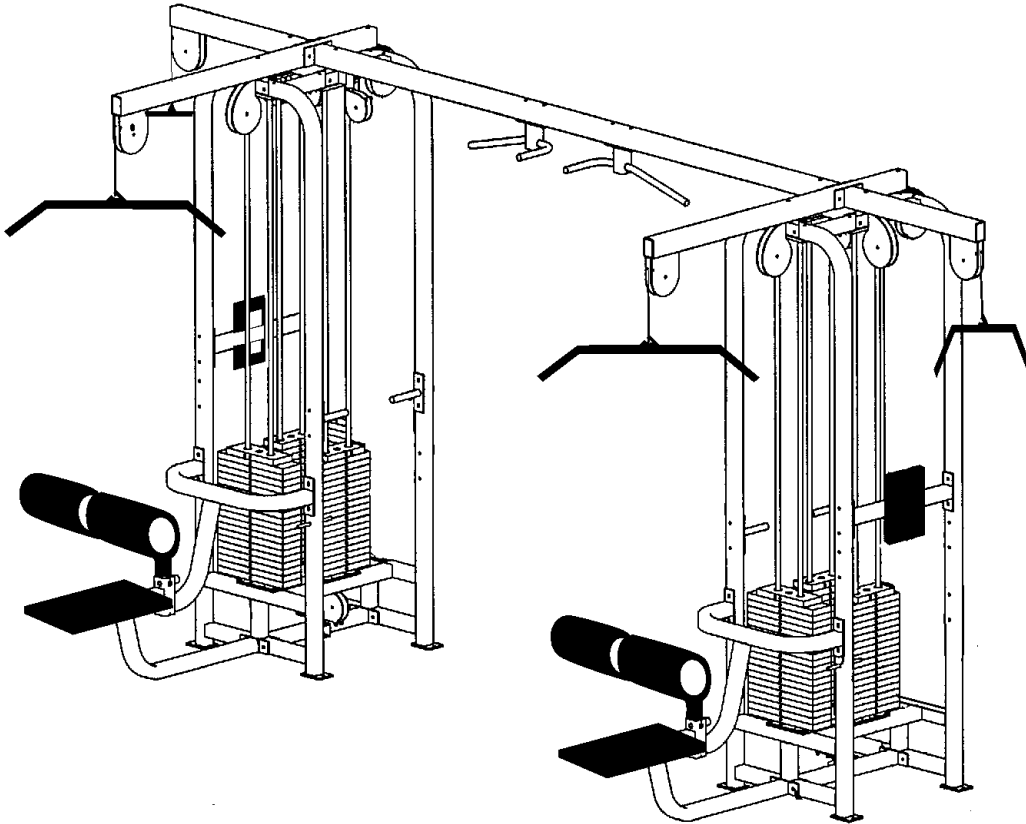

**6 STACK MULTI-JUNGLE (SM60)  
WITH HIGH & LOW PULLEYS  
UNPACKING AND ASSEMBLY INSTRUCTIONS**



The SM60 comes partially assembled. Follow the steps below to complete the assembly.



**WARNING:** COMPONENTS OF THE SM60 ARE LARGE AND HEAVY. USE CAUTION WHEN ASSEMBLING THIS MACHINE.

**MATERIALS AND TOOLS REQUIRED FOR ASSEMBLY**

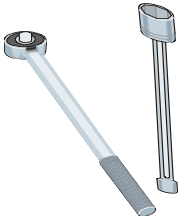

1/2", 3/8", 5/8" & 9/16"  
Socket wrench with  
extension



1/8"  
hex key wrench

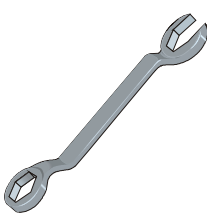

5/8" & 9/16"  
Combination wrench



Pinch bar

You will also need a piano dolly to lift and position the weight stacks and a ladder.

**ASSEMBLY TIME**

Two people can accomplish this assembly in approximately 2 hours.

## UNPACKING

Follow the steps below when unpacking the components of the SM60.

1. **Cut off the shipping wrapper.**
2. **Remove the parts boxes and shipping boards.**
3. **Remove the items in the parts boxes.** These items are shown in Figure 1.
  - A. Remove the bolts bag.
  - B. Remove the parts shown below. Parts that are used to build the SM60 are described in the section *HARDWARE* at the end of these instructions.



Figure 1. Parts box contents (box 1 on left, box 2 on right).

## ASSEMBLY

Figure 2 shows an assembled SM60.

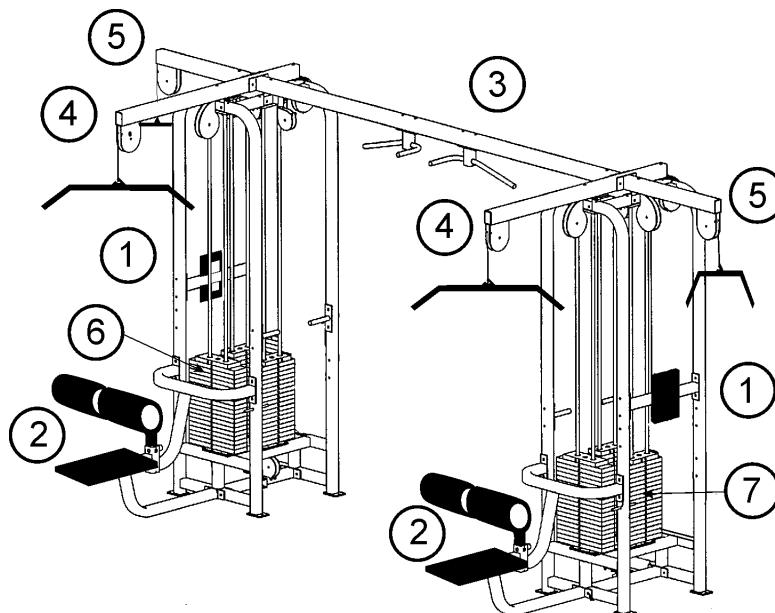

**Figure 2. SM60 main components.**

- |                        |                              |
|------------------------|------------------------------|
| 1. Cubes (2)           | 4. Lat tops (2)              |
| 2. Lat bench (2)       | 5. Tricep top (1)            |
| 3. Connecting beam (1) | 6. 300 lb. Weight stacks (3) |
|                        | 7. 190 lb. Weight stacks (3) |

1. **Place the two weight “cubes”** in their “final resting spots.” The cubes will be approximately 11’4” apart as shown in Figure 3.

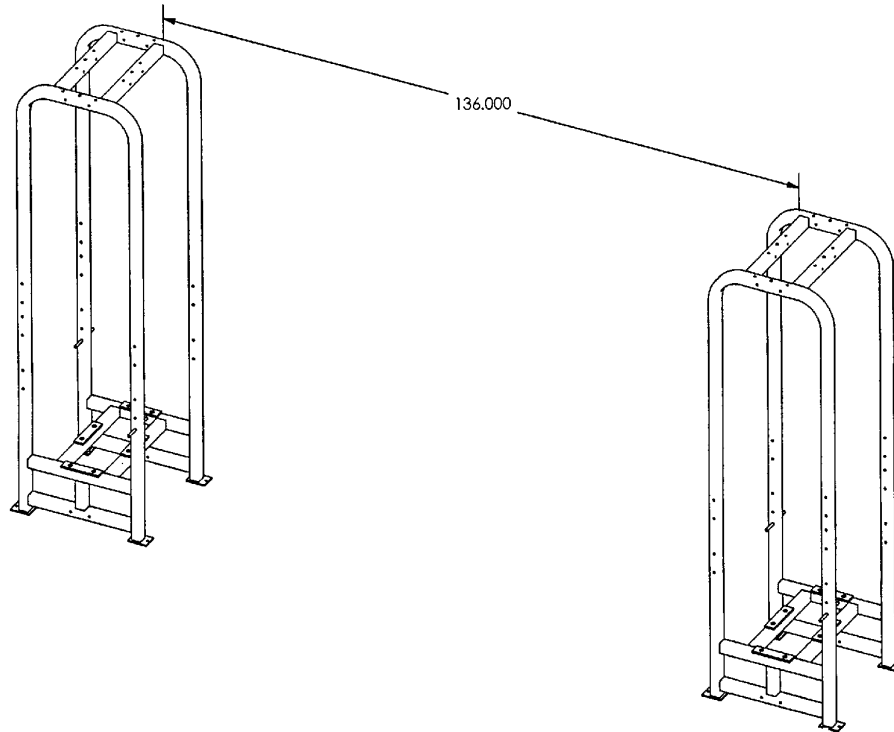

**Figure 3. Set the weight stack cubes.**

2. **Bolt on the teardrop pulleys above the benches** (see Figure 4) on both cubes using two  $3/8"$  x  $2-3/4"$  hex head bolts (used to bolt the cross beam to the cross members and the adjustable pulley tops to the top beams). Include the  $3/8"$  flat washer, end cap washers, end caps and  $3/8"$  Nyloc (locknut). Use the bolt configuration shown in Figure 5. You may wish to use a pinch bar to align the bolt holes.

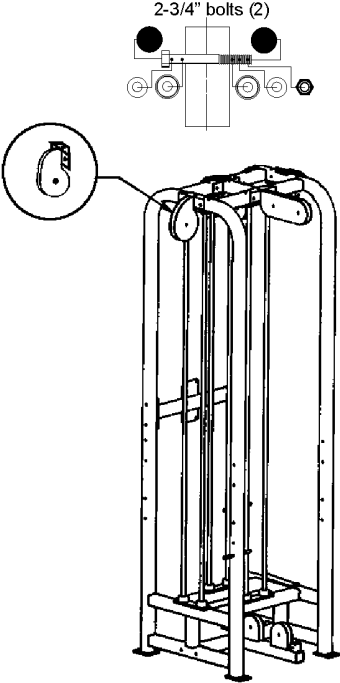

Figure 4. Bolt on the teardrop pulleys.

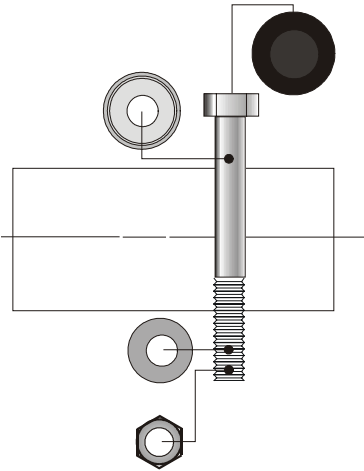
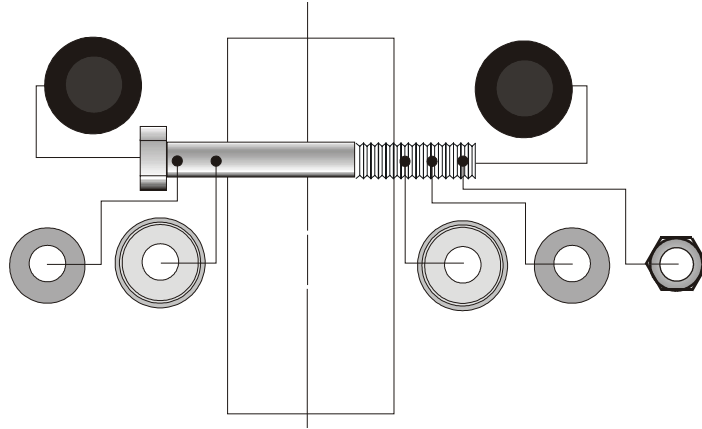
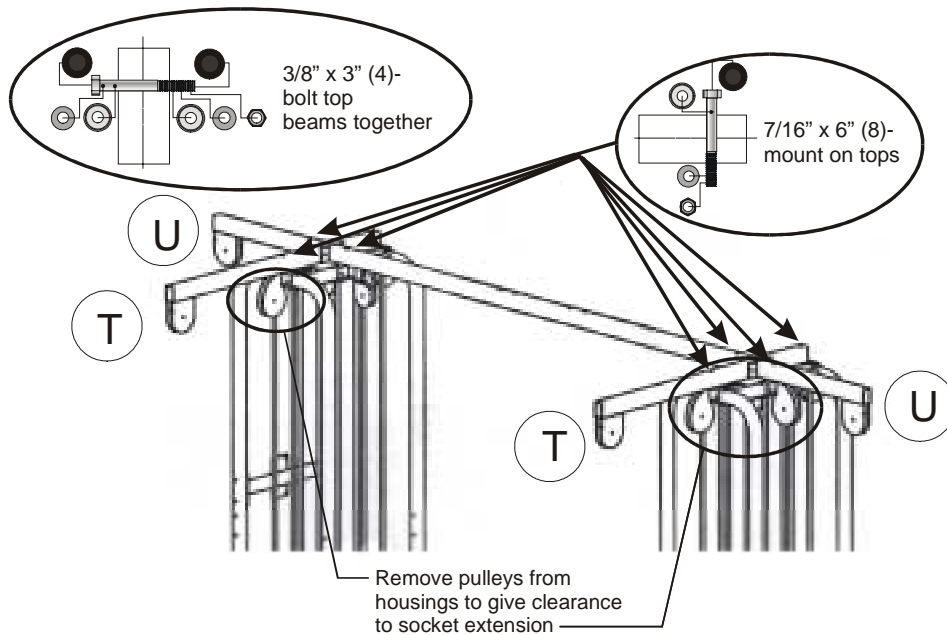

Figure 5. Configuration for 6" bolts.



**Figure 6. Configuration for 2-3/4" and 3" bolts.**

3. **Bolt on the connecting beam** (part 3 from Figure 2) using a 5/8" socket with extension and combination wrench, to the cubes using two of the large 7/16" x 6" bolts, 7/16" washers, and 7/16" nuts, end cap washers and end caps. Figure 7 shows the connected cubes.



**Figure 7. Bolt on the connecting beam, lat tops, tricep tops.**

4. **Mount the 56" lat tops** (part T) to the cells using a 5/8" socket and combination wrench by inserting two of the large 7/16" by 6" bolts using the hardware configuration shown. **Mount the 29" tricep tops** (part U) to the frame and connecting beam (See Figure 7). Use the hardware configuration shown. You will need to remove the pulleys from the teardrop pulley assemblies to gain clearance for the socket wrench extension. Leave the pulleys out of the housings until the cables have been installed.

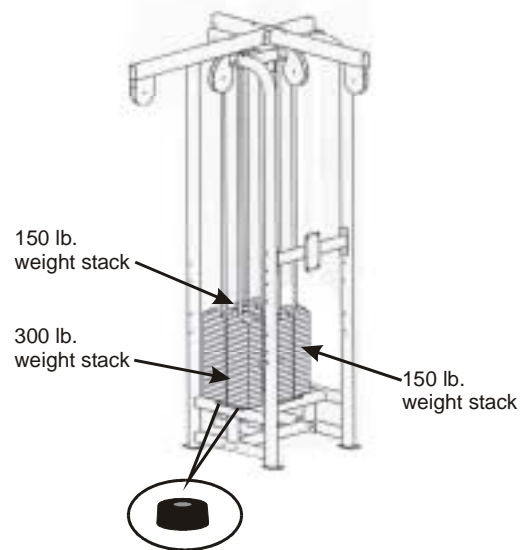

**Figure 8. Mount rubber bumpers and the weight stacks.**

5. **Install the weight stacks.** To do this:
  - A. Using a 9/16" socket and combination wrench, remove the tricep back rest bolts (see Figure 9).
  - B. Using a 9/16" socket and combination wrench, unbolt the top plate and remove the guide rods (see Figure 9).

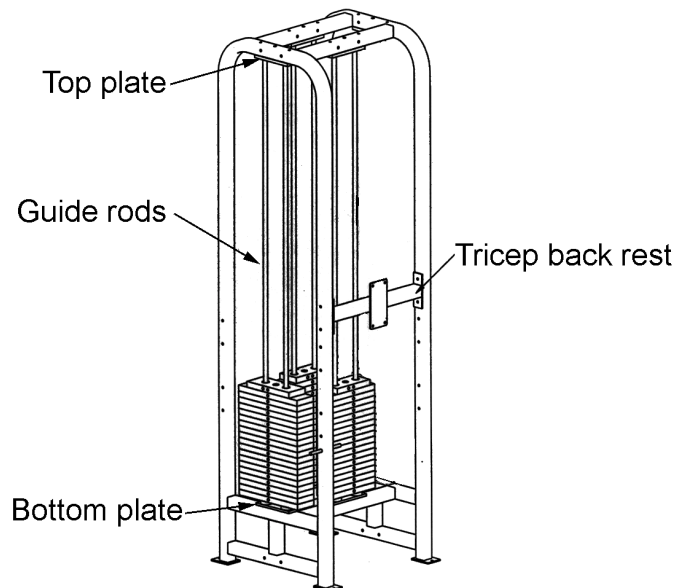

**Figure 9. Remove the tricep back rest, the top plate and the guide rods.**



- C. **Prepare the weight stack.** Slide the guide rods (2) through the weight stacks (1) as shown below. Place rubber bumpers (3) on the bottoms of each guide rod. Make sure the pull pin (4) is in the bottom weight plate.
- D. **Flip over the weight stacks.** When shipped, the weight stacks have the pull pins facing upward. You will need to flip the stacks over so that the pull pins are facing outward when they are loaded onto the machine. Since the pull pins will be facing downward when they are flipped over, it is recommended that you put the stacks on a padded carpet to keep the pins from being damaged.
- E. **Set the weight stacks onto the machine.** Using a piano dolly, lift the weight stacks over the bottom plate and set the stacks onto the rubber bumpers with the plate numbers facing outward. The 300 lb weight stack need to be facing the “sides” of the cells (where the lat benches will be attached). The 190 lb weight stacks will need to be facing the “outsides” and “insides” of the cells (where the tricep pulleys and crossover pulleys will be attached). Make sure the pull pins are facing outward.

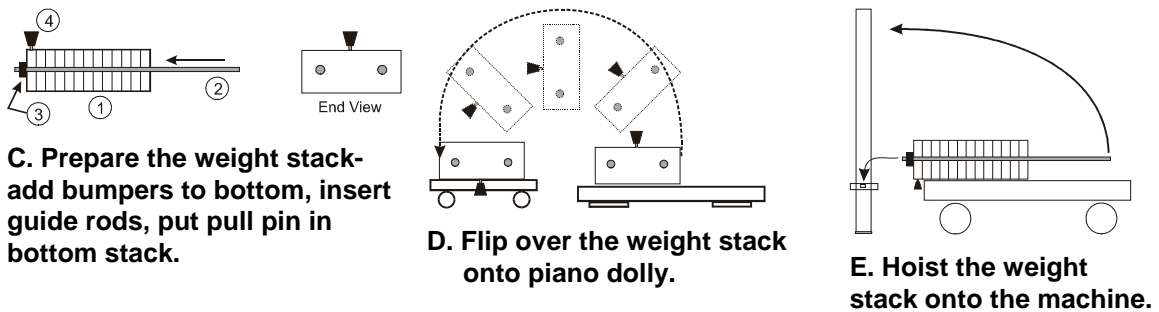

Figure 10. Install the weight stacks.

- F. **Bolt on the top plate to the top of the cells** with the top plate on the guide rods as shown in Figure 11 using a 9/16” socket and combination wrench and the 3” bolts (with cap washers) that were previously inserted.

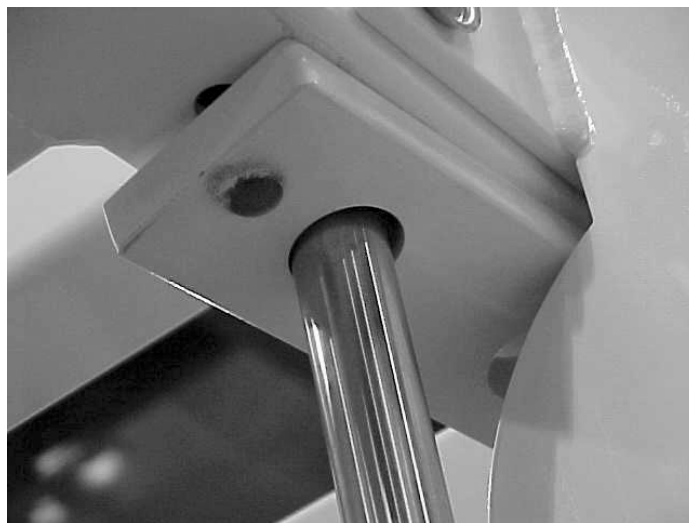
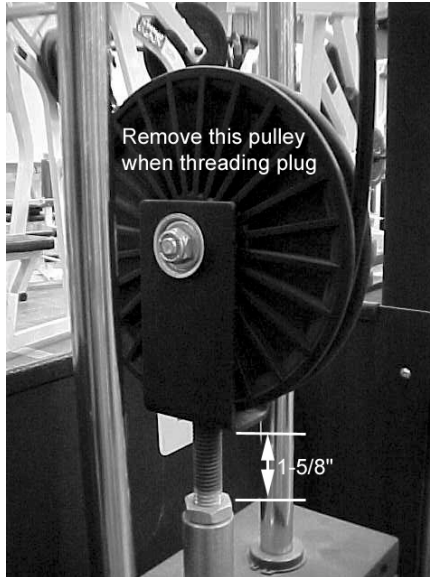

Figure 11. Bolt on the top plate.

- Bolt the floating pulleys into the 190 lb weight stacks** used for the crossovers using a  $\frac{7}{8}$ " combination wrench. You will need to remove the pulley from the housing to thread the plug into the weight stack bayonet. Make sure the  $\frac{9}{16}$ " jam nut is threaded  $1\text{-}\frac{5}{8}$ " away from the pulley as shown in Figure 12. Leave the pulleys out since you will need to have them out when the cable is routed.



**Figure 12. Bolt the floating pulleys into the crossover 190 lb weight stacks.**

- Mount the lat benches to the frame.** Using the bolts specified in Figure 14 and a  $\frac{9}{16}$ " socket and combination wrenches, mount the benches as shown in Figures 13 and 14.

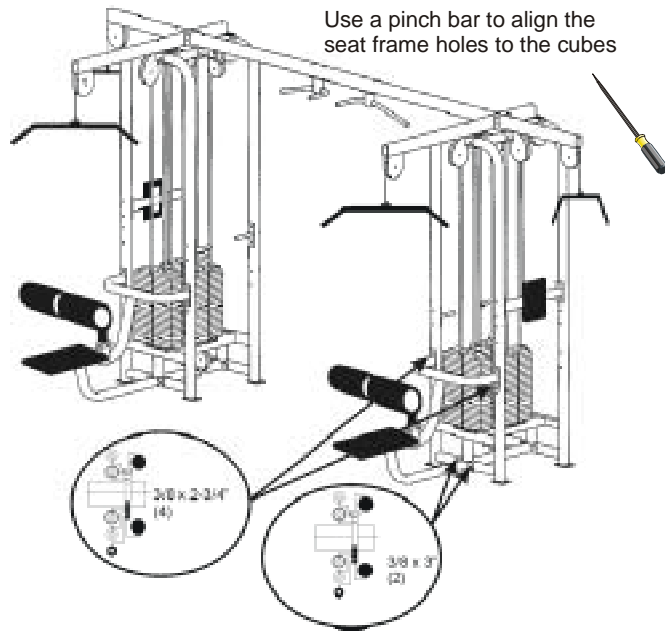

Figure 13. Mount the benches to the frame.

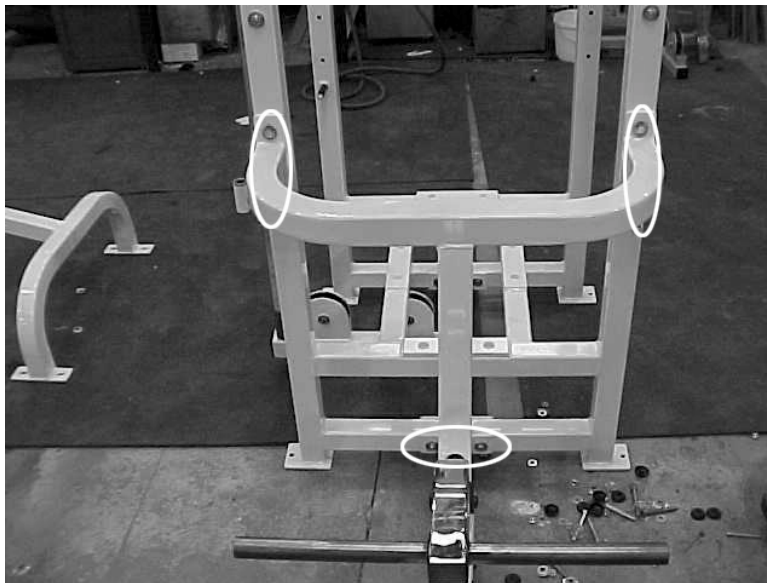

Figure 14. Bolt locations on the frame.

## INSTALLING THE CABLES

The SM60 uses six cables. There are two different types of cable used on the SM60. They are:

1. Crossover cables (ball end cables) (2).
2. Lat pulldown and tricep cables (4).

The lat and tricep cables can be identified by their short length, the low row cables can be identified by their long length and the crossover cables can be identified by the ball on the end of the cable. The routings for these cables are shown in the figures below.

**NOTE:** YOU MUST REMOVE ALL PULLEYS TO ROUTE THE CABLES. USE A 9/16" COMBINATION WRENCH AND SOCKET TO DO THIS (SEE FIGURE 15). YOU MAY WISH TO REMOVE THE SHOULDER BOLTS (FIGURE 15 RIGHT SIDE) BY USING A 3/8" COMBINATION WRENCH AND A 1/8" HEX KEY WRENCH. WHEN YOU HAVE ROUTED THE CABLES, REPLACE ALL PULLEYS AND PLACE END CAPS ON NUT AND BOLT ENDS. YOU MAY NEED TO PRY THE PULLEY HOUSINGS OPEN TO REPLACE THE PULLEYS.

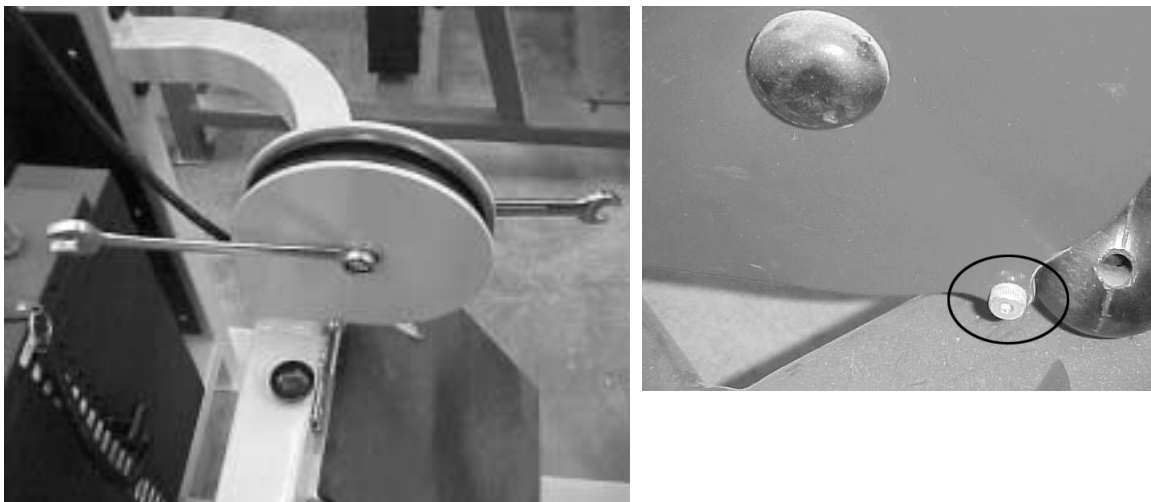

**Figure 15. Removing the pulley bolts.**

### **CROSSOVER CABLE ROUTING**

Once you've removed the pulleys as described previously, route the two crossover cables as shown in Figure 16.

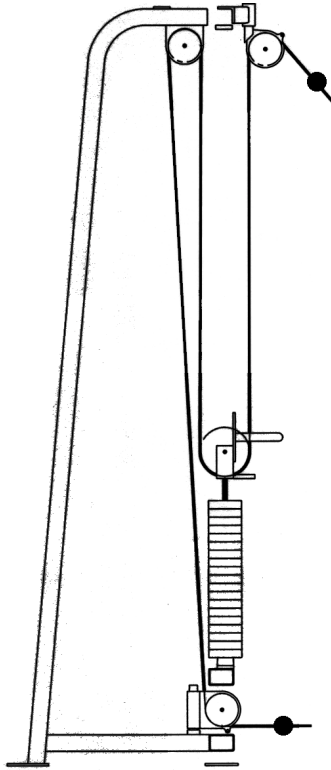

**Figure 16. Crossover cable routing.**

Bolt the cable to the weight stacks as shown in Figure 17. Thread the 7/8" nut up on the cable bolt as shown at left. Screw the bolt down into the weight stack as shown at right. Tighten the bolt with a 7/8" combination wrench.

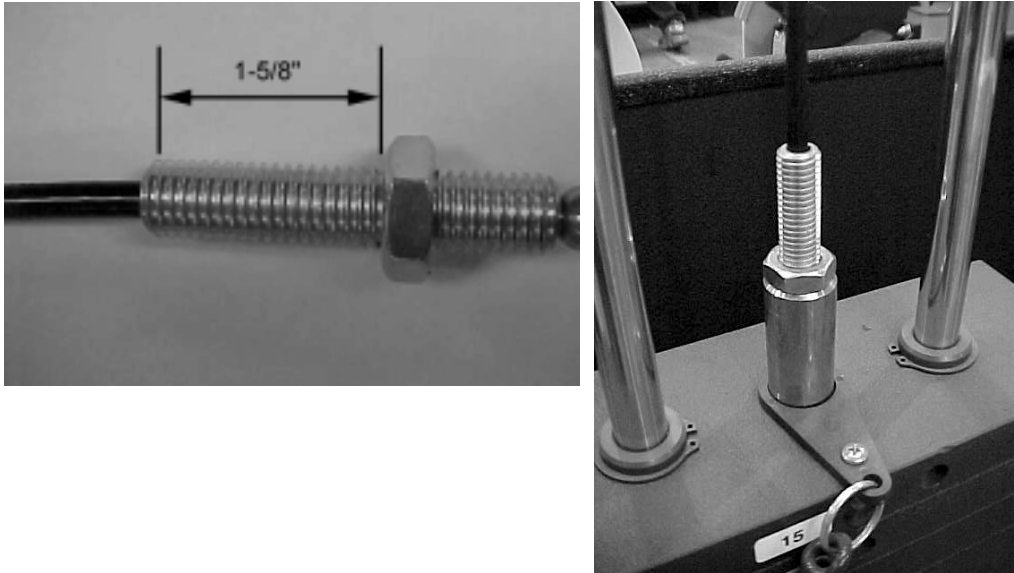

Figure 17. Screw the cable into the weight stack.

### **LAT PULLDOWN CABLE ROUTING**

Route the lat pulldown cable as shown in Figure 18. Screw the cable into the weight stack as shown previously in Figure 18.

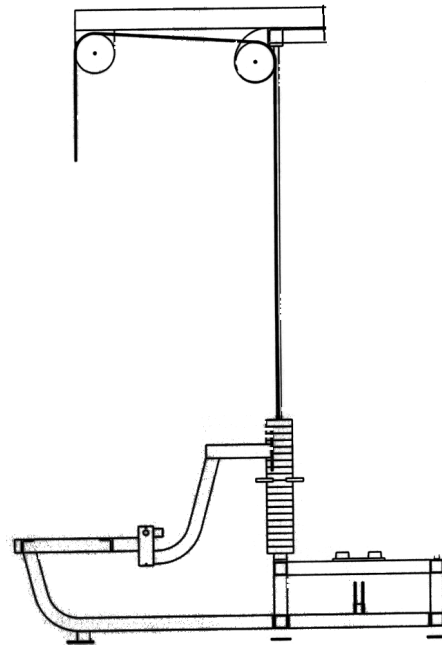
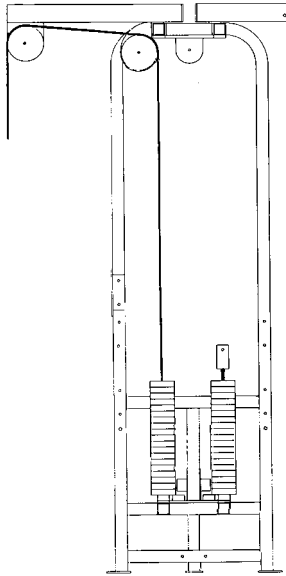

Figure 18. Lat pulldown cable routing.

**TRICEP PUSHDOWN CABLE ROUTING**

Route the tricep pushdown cable as shown in Figure 19. Screw the cable into the weight stack as shown previously.



**Figure 19. Tricep pushdown cable routing.**

**HARDWARE**

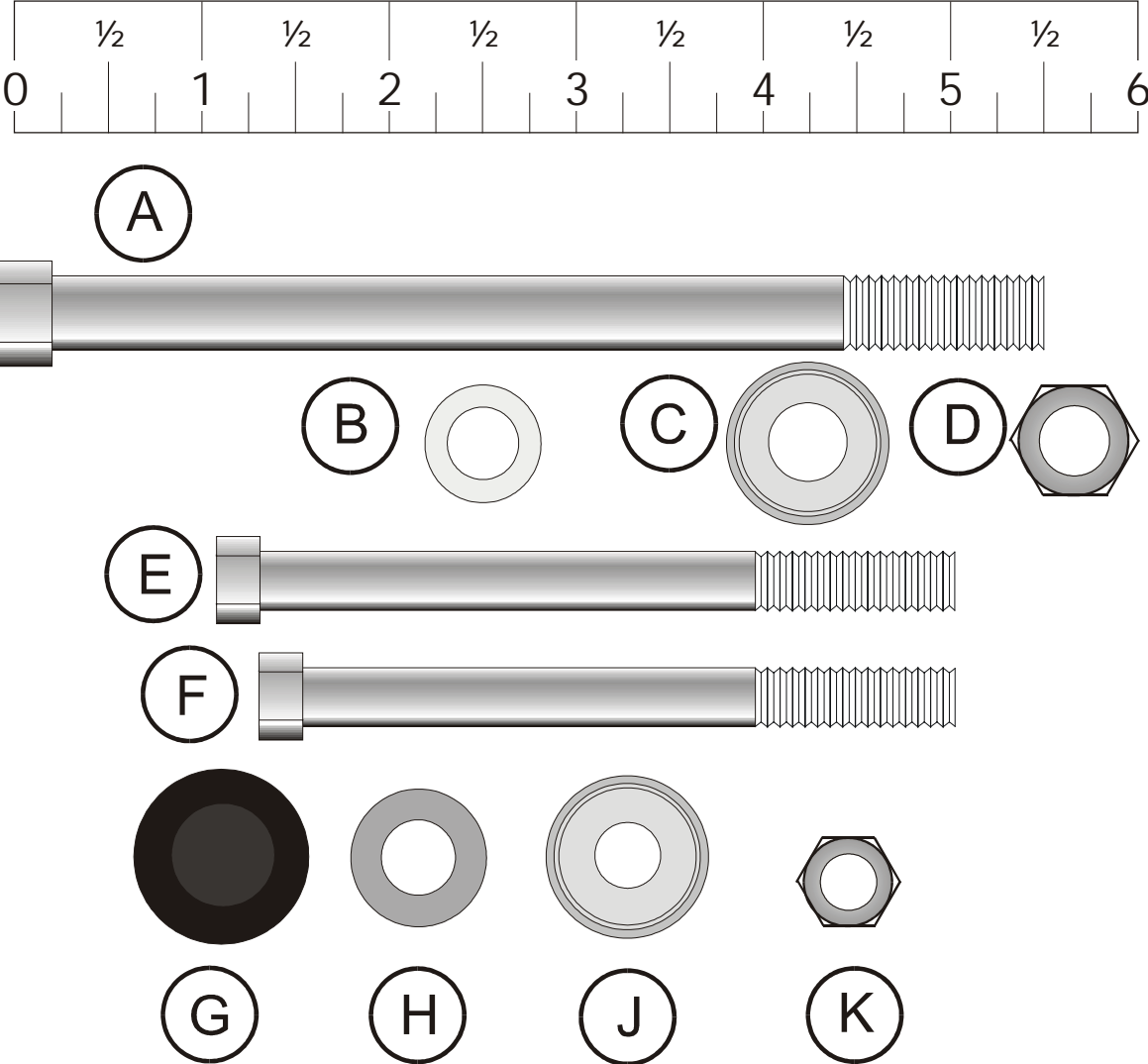

**Hardware Figure 1. Assembly Parts.**



The parts shown in Hardware Figure 1 are used to assemble the SM60. They are:

- A. 7/16" x 6" hex head bolt (used to bolt the tricep top beams, lat top beams, and connecting beam to the tops of the cubes)
- B. 7/16" flat washer
- C. 7/16" cap washer (used on the head end of the 6" bolt so end cap will fit on the nut)
- D. 7/16" hex head nut
- E. 3/8" x 3" hex head bolt (used to bolt the tricep pushdown beams to the connecting beam)
- F. 3/8" x 2-3/4" hex head bolt (used for all other connections)
- G. End caps (bolt covers)
- H. 3/8" flat washer
- J. 3/8" end cap washers (end caps snap onto them)
- K. 3/8" Nyloc (locknut)

The part shown in Hardware Figure 2 is the 9/16" cable jam nut that's used to secure the cables to the weight stacks.

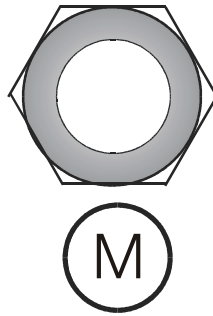

**Hardware Figure 2. Cable jam nut.**

- M. Cable jam nut

Hardware Figure 3 shows the types of cables that are included with the SM60.

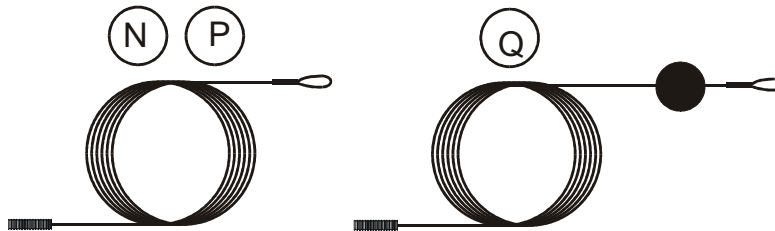

**Hardware Figure 3. Cables.**

- N. Lat pulldown cables (same as tricep cable) (2)
- P. Tricep cable (same as lat pulldown cables) (2)
- Q. Crossover cables (ball end) (2)

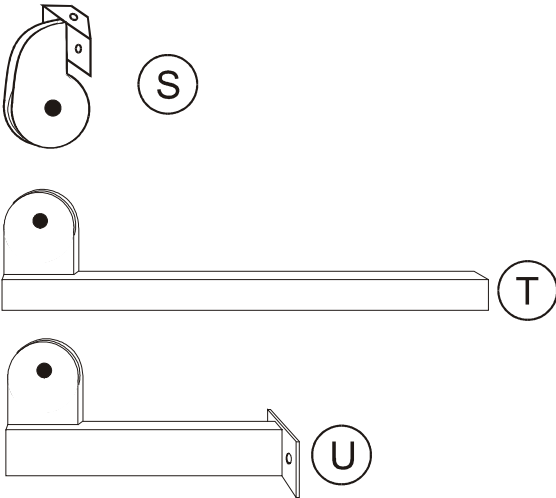

**Hardware Figure 4. Top assemblies.**

- S. Teardrop pulleys (bolt on above lat pulldown) (2)
- T. 56" Lat tops (bolt to top of cells with pulleys above lat benches) (2)
- U. 29" Tricep top (bolt on to 56" lat top bar) (2)

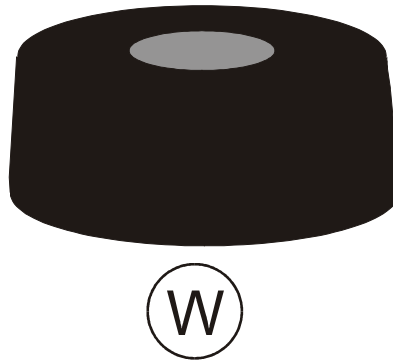

**Hardware Figure 5. Weight stack rubber bumpers.**

W. Weight stack rubber bumpers (inserted under weight stacks)

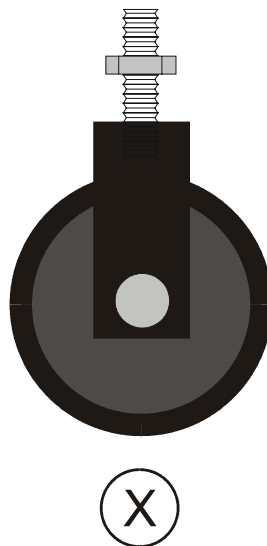

**Hardware Figure 6. Floating pulleys.**

X. Floating pulleys (bolt to 190 lb cable crossover weight stacks)

## PARTS LIST

Part #	ID	Description	Quantity
	<b>Main components</b>		
	1	Cubes	2
	2	Lat bench	2
	3	Connecting beam	1
	4	Lat top	2
	5	Tricep top	2
	6	300 lb weight stack	2
	7	190 lb weight stack	4
	<b>Cables, caps &amp; nuts</b>		
0017-00103-0234	M	Cable jam nut	12
0017-00101-1408	N	Lat pulldown cable	2
0017-00101-1408	P	Tricep cable	2
0017-00101-1561	Q	Crossover cable	2
	<b>6" bolt hardware</b>		
0017-00101-1561	A	7/16" x 6" hex head bolt	8
0017-00104-0363	B	7/16" flat washer	8
0017-00104-0366	C	7/16" cap washer	8
0017-00103-0233	D	7/16" Nyloc nut	8
	<b>2-3/4" &amp; 3" bolt hardware</b>		
0017-00101-1422	E	3/8" x 3" hex head bolt	4
0017-00101-1408	F	3/8" x 2-3/4" hex head bolt	16
0017-00042-0969	G	End cap	64
0017-00104-0313	H	3/8" flat washer	64
0017-00104-0368	J	3/8" end cap washer	64
0017-00103-0217	K	3/8" Nyloc nut	32
	<b>Pulleys and bumpers</b>		
0017-00042-0993	W	Weight stack rubber bumper	12
	X	Floating pulley	2
	<b>Handle and bar hardware</b>		
		Safety carabiner	6
		Crossover handle	3
		Tricep bar	2
		Lat bar	2
		Leg strap	1

<p>0017-00101-1413 0017-00104-0368 0017-00103-0217</p>	<p><b>Pulley hardware (installed)</b></p>	<p>1-3/4" Bolt Cap washer 3/8" Nyloc nut</p>	
<p>0017-00101-1413 0017-00104-0313 0017-00103-0217</p>	<p><b>Floating pulley hardware (installed)</b></p>	<p>1-3/4" Bolt Flat washer 3/8" Nyloc nut</p>	