

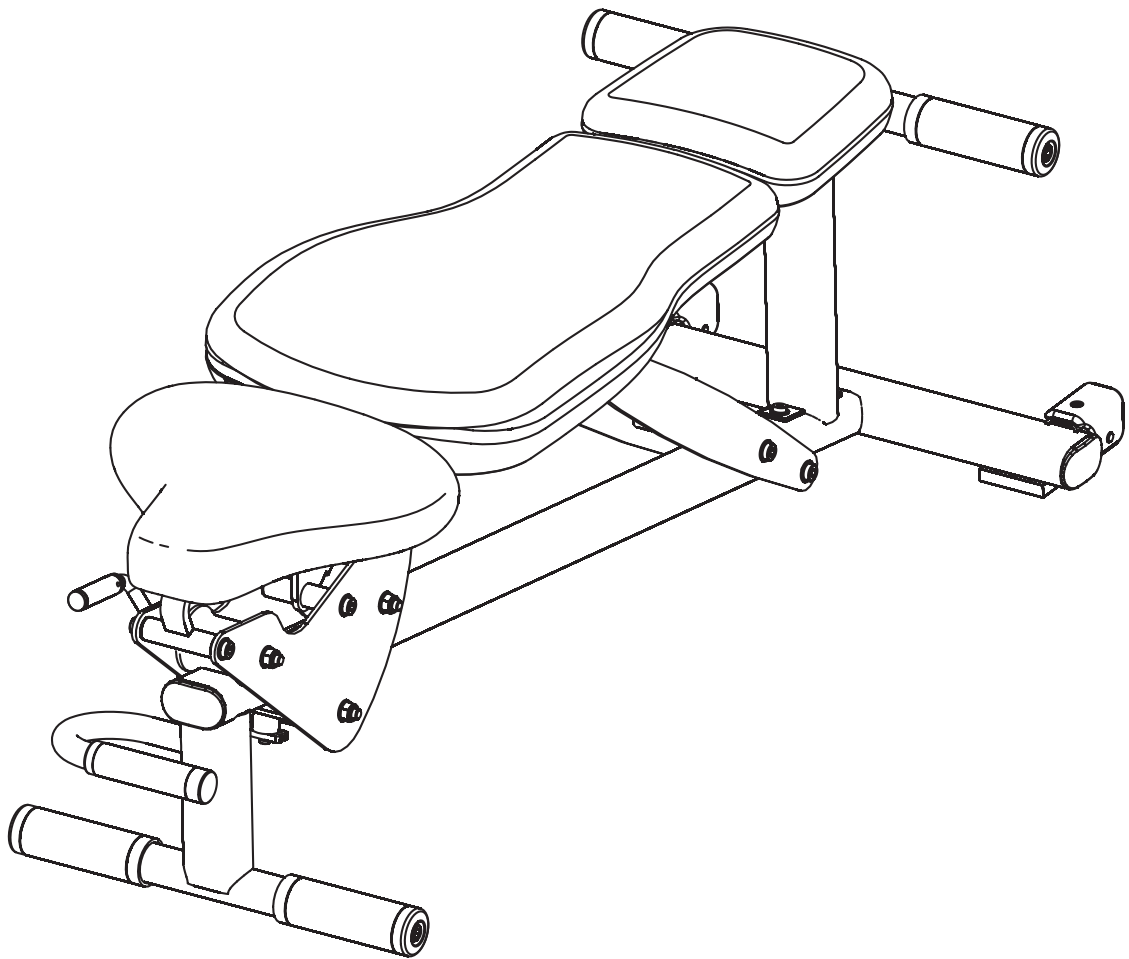

## LFADJ ADJUSTABLE BENCH USER GUIDE



### **WARNING:**

Read and follow all directions for each step to insure proper assembly of this product.

CLASS H (Consumer Use Only)  
PART # 8362301 REV. A  
VERSION: LFADJ-002  
DATE: 08-23-07

# TABLE OF CONTENTS

Safety Statement . . . . .	2	Assembly Instructions . . . . .	6
Bench Dimensions. . . . .	3	General Maintenance . . . . .	15
Components List . . . . .	4	Warranty Statement/Notes . . . . .	16
Hardware . . . . .	5	Contact Information. . . . .	17

## IMPORTANT SAFETY INFORMATION



THERE IS A RISK ASSUMED BY INDIVIDUALS WHO USE THIS TYPE OF EQUIPMENT. TO MINIMIZE RISK FOLLOW THESE RULES!

1. Before using, read all the warnings and instructions on the use of this machine. Warnings are located in this manual as well as on the ADJUSTABLE BENCH. Use only for intended exercise. Store the ADJUSTABLE BENCH with the back pad locked in the flat position. **DO NOT** modify the machine.
2. Life Fitness **STRONGLY** recommends seeing a physician for a complete medical exam before undertaking an exercise program, particularly if the user has a family history of high blood pressure or heart disease, or is over the age of 45, or smokes, has high cholesterol, is obese, or has not exercised regularly in the past year.  
  
If, at any time while exercising, the user experiences faintness, dizziness, pain, or shortness of breath, he or she must stop immediately.
3. Keep body and clothing free of all moving objects.
4. Inspect the machine before use. **DO NOT** use it if it appears damaged. **DO NOT** attempt to fix a broken or jammed machine. Notify your authorized Life Fitness dealer before use and have repairs made by an authorized service technician.
5. Setup and position the ADJUSTABLE BENCH on a flat and solid surface before use.
6. Be certain that the pin adjustment is completely inserted. Use only the pin provided by the manufacturer. If unsure, call your authorized Life Fitness dealer.
7. Make sure all spring loaded pull pins are fully engaged in the adjustment position before use.
8. Children and pets must not be allowed near this machine. Supervise teenagers.

### Please note:

- \* Thank you for purchasing the Life Fitness LFADJ ADJUSTABLE BENCH. Please read these instructions thoroughly and keep them for future reference. This product must be assembled on a flat, level surface to assure its proper function.
- \* **DO NOT** securely tighten any frame connections until the entire frame has been assembled, unless otherwise stated.

**NOTE:** In a continual effort to improve our products, specifications are subject to change.  
© 2007 Life Fitness, a division of Brunswick Corporation. All rights reserved.  
Life Fitness is a trademark of Brunswick Corporation.

# BENCH DIMENSIONS

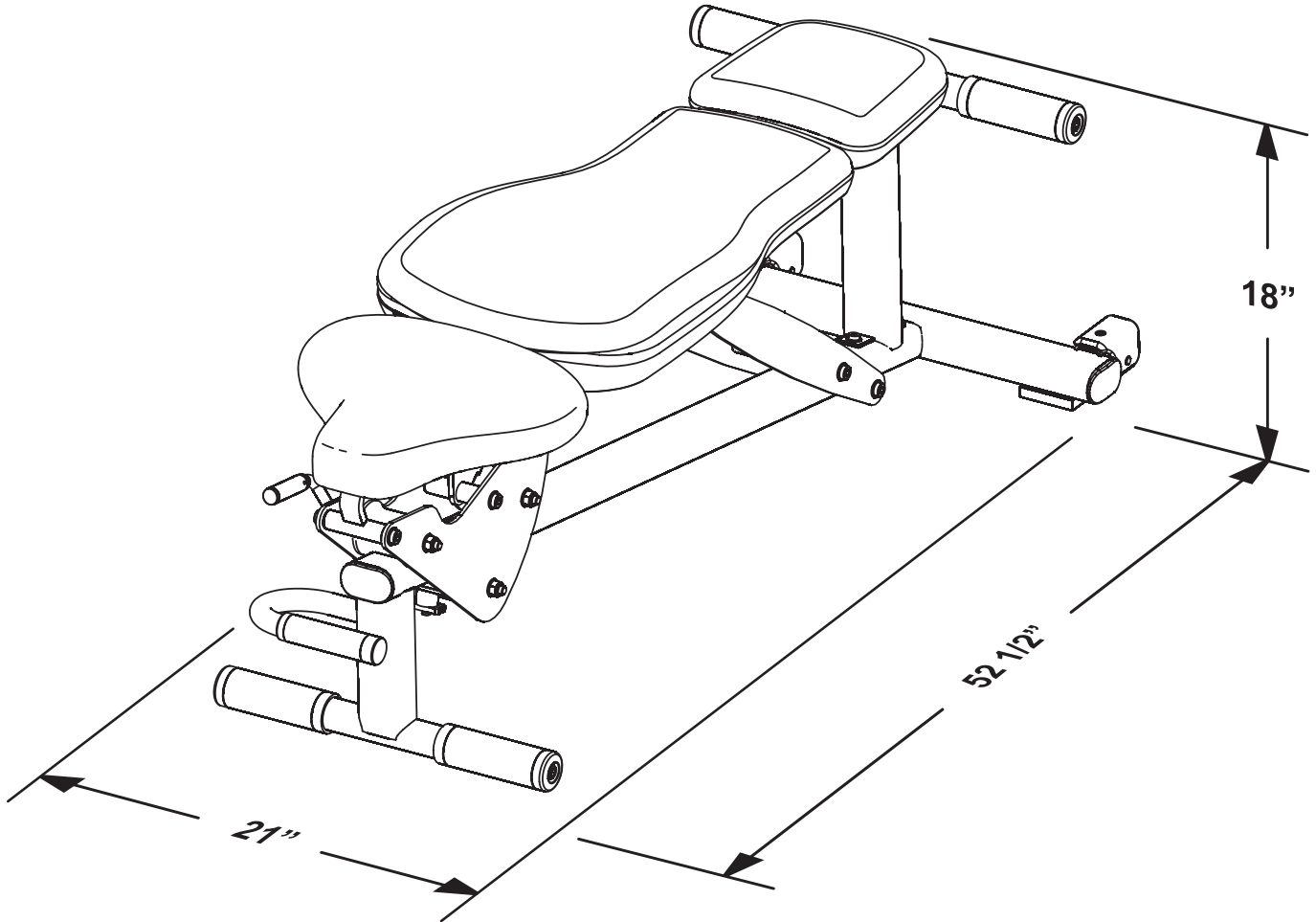

**Height:**

Flat	18 inches	(457mm)
Fully Upright	42 3/8 inches	(1076mm)

**Width:**

21 inches	(530mm)
-----------	---------

**Length:**

52.5 inches	(1335mm)
-------------	----------

**Bench Weight:**

77 pounds	(35Kg)
-----------	--------

**Max User Weight:**

300 pounds	(136.08Kg)
------------	------------

**Max Training Weight:**

300 pounds	(136.08Kg)
------------	------------

# COMPONENTS LIST

ITEM NO.	QTY.	PART NO.	DESCRIPTION
1	1	<del>6351401</del>	MAIN FRAME ASSEMBLY
2	1	<del>8289401</del>	SEAT ADJUSTMENT HANDLE
3	3	<del>7646301</del>	ROLLER
4	1	8351301	PAD HOLDER ASSEMBLY
5	2	8328501	BACKREST SUPPORT
6	1	7474301	HEADREST PAD
7	1	7474101	BACK PAD
8	4	<del>3237401</del>	HOLE PLUG
9	1	7704301	SEAT SUPPORT PLATE
10	1	7297101	SEAT PAD
11	1	8263601	SEAT PIVOT BAR
12	1	<del>7703902</del>	SEAT ADJUSTMENT ASSEMBLY
13	1	7777301	TOUCH UP PAINT, PL
14	1	<del>8259800</del>	ROLLER CARRIAGE
15	1	7690201	BUMPER SLEEVE
16	1	<del>8312701</del>	UPRIGHT TUBE
32	1	7705201	SEAT ADJUSTMENT PIN
33	1	6411801	COMPRESSION SPRING
<b>HARDWARE (Blister Pack 8313901)</b>			
17	3	3256218	M10 X 110MM SCREW
18	3	3242002	M10 HEX NYLOCK NUT
19	32	3102514	3/8" FLAT WASHER
20	4	<del>6020601</del>	1/2" X 1/2" BUSHING
21	2	<del>7705705</del>	1/2" X 3 1/4" SLOTTED SHAFT
22	14	3256201	M10 X 20MM SCREW
23	1	<del>7705801</del>	BACKREST SUPPORT BRACE
24	4	3251704	M10 X 35MM SCREW
25	1	<del>7705404</del>	1/2" X 6" SLOTTED SHAFT
26	2	3242004	M8 HEX NYLOCK NUT
27	1	<del>7705401</del>	1/2" X 1 1/2" SLOTTED SHAFT
28	4	3256202	M10 x 25MM SCREW
29	1	3102802	3/8" NYLOCK NUT
30	1	3249212	3/8" x 2.75" HEX SOCKET SCREW
31	2	3255808	M8 x 55MM HEX SOCKET SCREW
34	2	<del>7705804</del>	<del>1/2" X 5 1/4" SHAFT</del>
35	1	7705803	<del>1/2" X 3 1/4" SHAFT</del>
36	6	3104901	3/4" X 1" BUSHING
37	6	3102509	5/16" FLAT WASHER
<b>REQUIRED TOOLS</b>			
* 7mm ALLEN WRENCH			
* 8mm ALLEN WRENCH			
* 17mm WRENCH			
* 5/16" ALLEN WRENCH			
* 5 mm ALLEN WRENCH			
*13 mm ALLEN WRENCH			
* 9/16" WRENCH			

# HARDWARE:

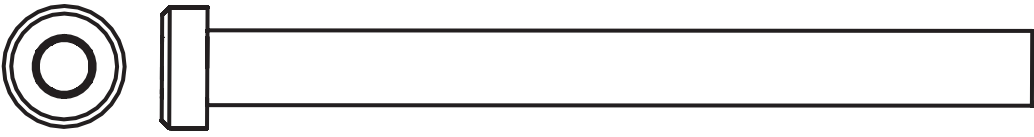

M10 X 110MM SCREW (#17)



M10 NYLOCK NUT (#18)

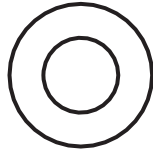

3/8" WASHER (#19)

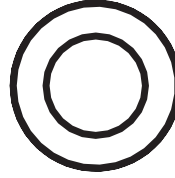

1/2" x 1/2" BUSHING (#20)

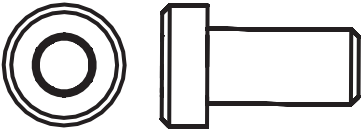

M10 X 20MM SCREW (#22)

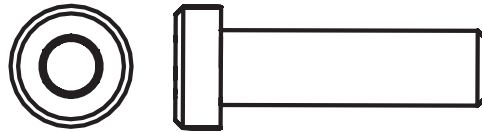

M10 X 35MM SCREW (#24)



M8 NYLOCK NUT (#26)

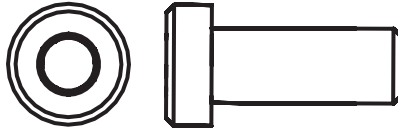

M10 X 25MM SCREW (#28)



5/16" WASHER (#37)



3/8" NYLOCK NUT (#29)

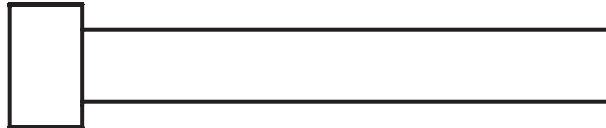

3/8 x 2 3/4" HEX SOCKET SCREW (#30)



M8 x 55MM HEX SOCKET SCREW (#31)

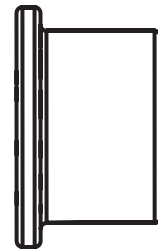
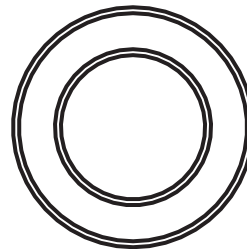

3/4" x 1" BUSHING (#36)

Centimeters

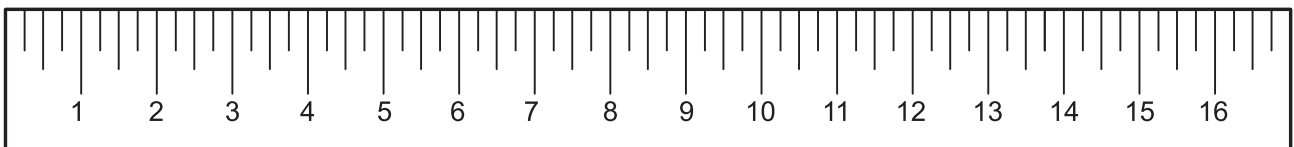

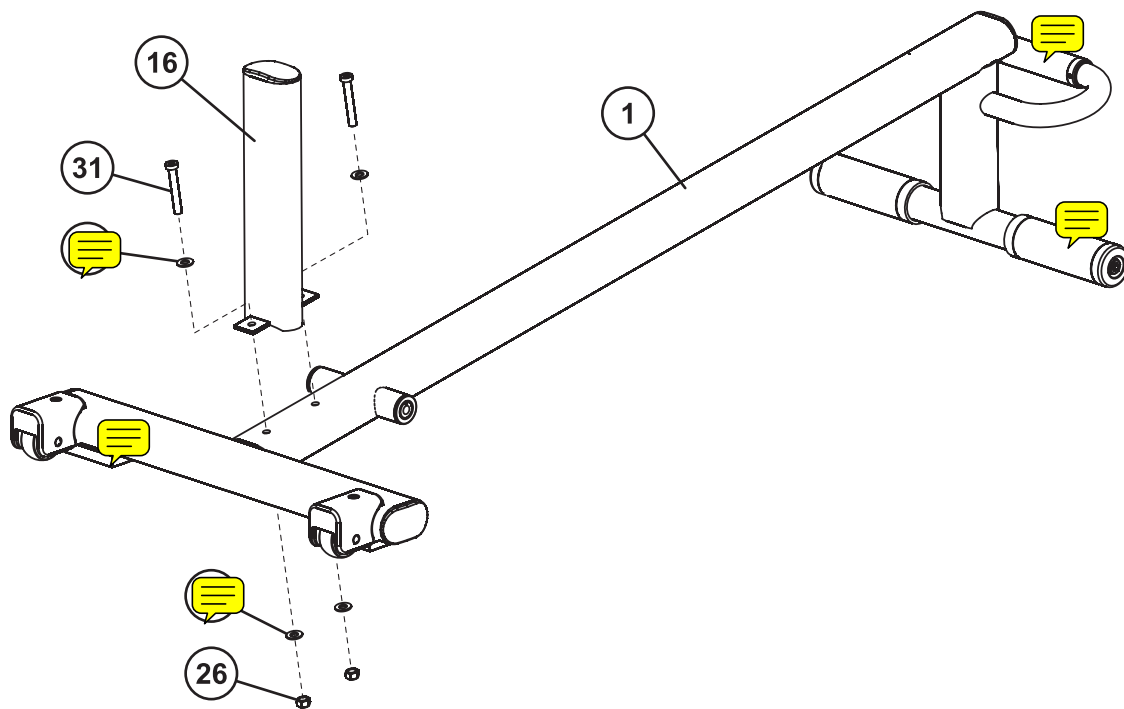

**STEP 1:**

- ❑ Assemble the UPRIGHT TUBE (16) to the MAIN FRAME ASSEMBLY (1) using two M8 x 55mm HEX SOCKET SCREWS (31), four 5/16" FLAT WASHERS (37), and two M8 HEX NYLOCK NUTS (26). Tighten the screws and nuts securely.

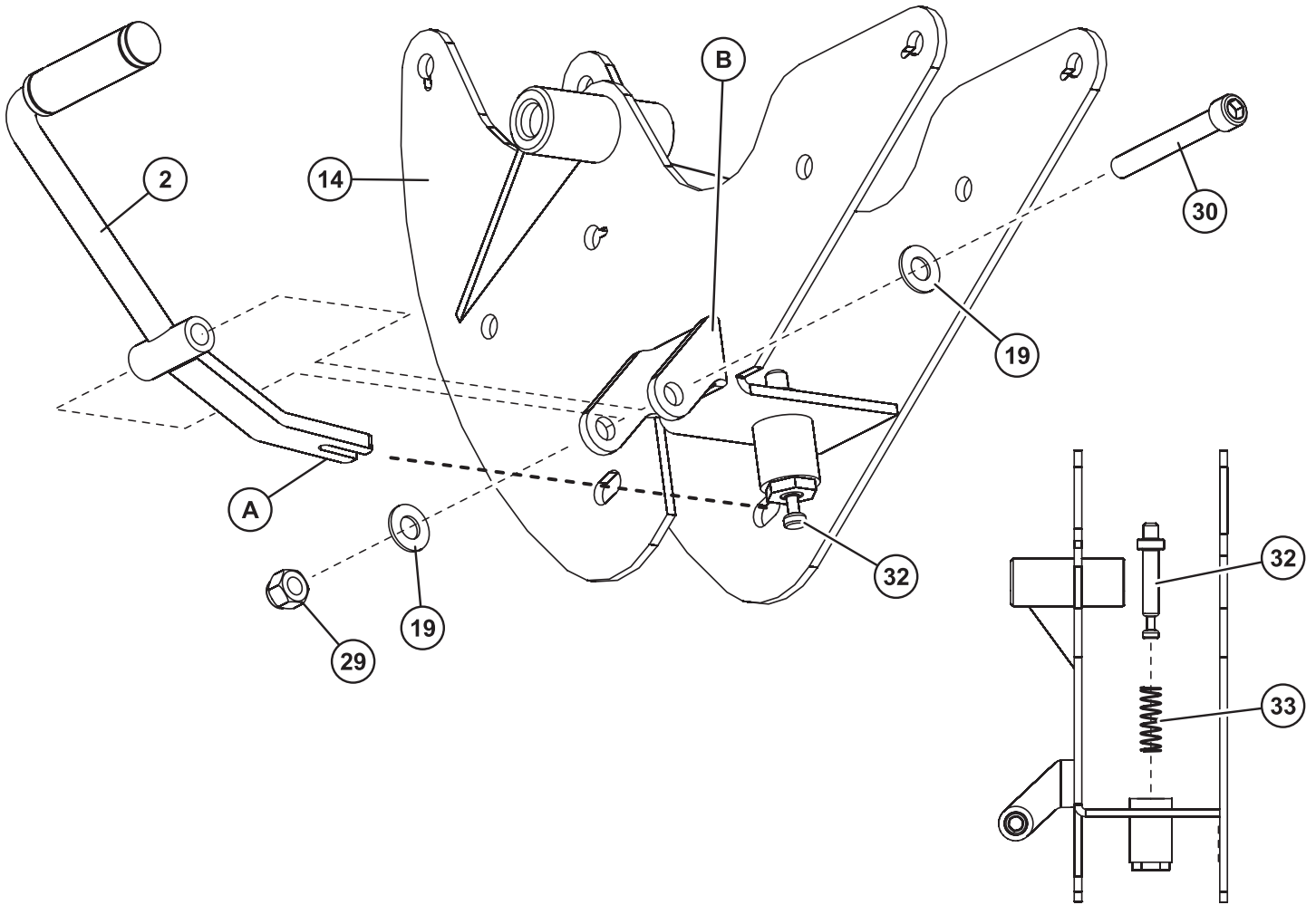

**STEP 2:**

- ❑ Insert the COMPRESSION SPRING (33) and SEAT ADJUSTMENT PIN (32) into the ROLLER CARRIAGE (14).
- ❑ With the SEAT ADJUSTMENT HANDLE (2) oriented as shown, press downward on the SEAT ADJUSTMENT PIN (32) and insert the FORK END (A) of the SEAT ADJUSTMENT HANDLE (2) onto the SEAT ADJUSTMENT PIN (32).

**NOTE: THE HANDLE ORIENTATION MUST BE POSITIONED AS SHOWN SO THE BEND IS IN THE CORRECT POSITION.**

- ❑ With the FORK END (A) of the SEAT ADJUSTMENT HANDLE (2) engaged with the SEAT ADJUSTMENT PIN (32), align the mounting holes of the SEAT ADJUSTMENT HANDLE (2) to the BRACKET (B) on the ROLLER CARRIAGE (14) and secure using one 3/8" X 2.75" HEX SOCKET SCREW (30), two FLAT 3/8" WASHERS (19), and one 3/8" NYLOCK NUT (29).

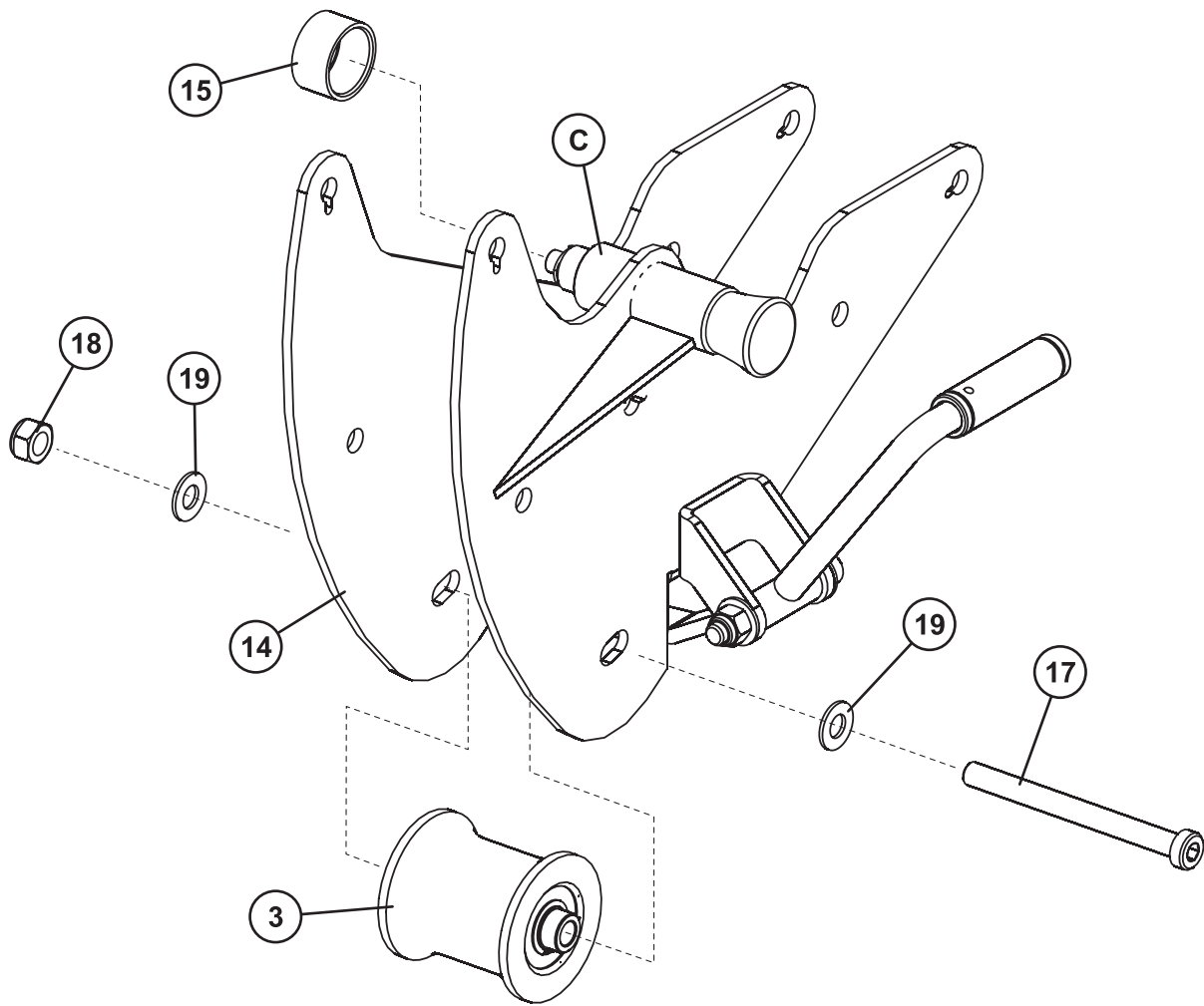

**STEP 3:**

- ❑ Assemble one ROLLER (3) to the bottom of the ROLLER CARRIAGE (14) using one M10 X 110mm SCREW (17), two FLAT 3/8" WASHERS (19), and one M10 HEX NYLOCK NUT (18). Slide the ROLLER (3) up the slot so it is positioned as closely to the SEAT ADJUSTMENT HANDLE (2) as possible. Tighten the screw and nut securely.
- ❑ Slide the BUMPER SLEEVE (15) over the INNER KNOB HOUSING (C).



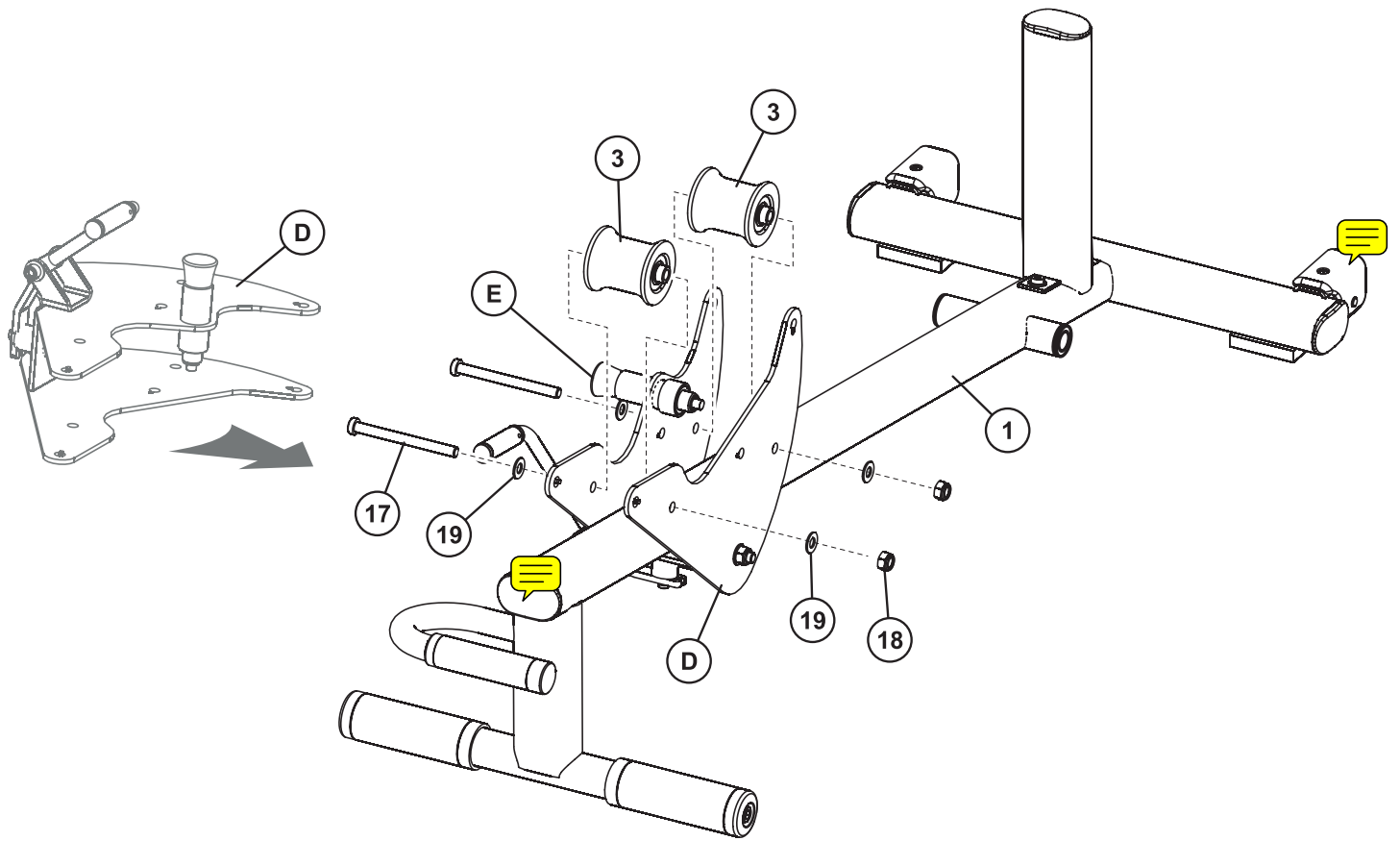

**STEP 4:**

- ❑ With the ROLLER CARRIAGE ASSEMBLY (D) oriented on its side, carefully position the ROLLER CARRIAGE ASSEMBLY (D) over the MAIN FRAME ASSEMBLY (1) and tilt into its final position as shown.

**NOTE: IF NECESSARY, PULL ON THE CARRIAGE KNOB (E) TO GET THE ROLLER CARRIAGE (D) ON THE MAIN FRAME ASSEMBLY (1).**

- ❑ Attach the two remaining ROLLERS (2) to the ROLLER CARRIAGE ASSEMBLY (D) using one M10 x 110mm SCREW (17), two FLAT 3/8" WASHERS (19), and one M10 HEX NYLOCK NUT (18) each. Tighten the screws and nuts securely.

**NOTE: THE TWO ROLLERS SHOULD BE POSITIONED ABOVE THE MAIN FRAME ASSEMBLY (1).**

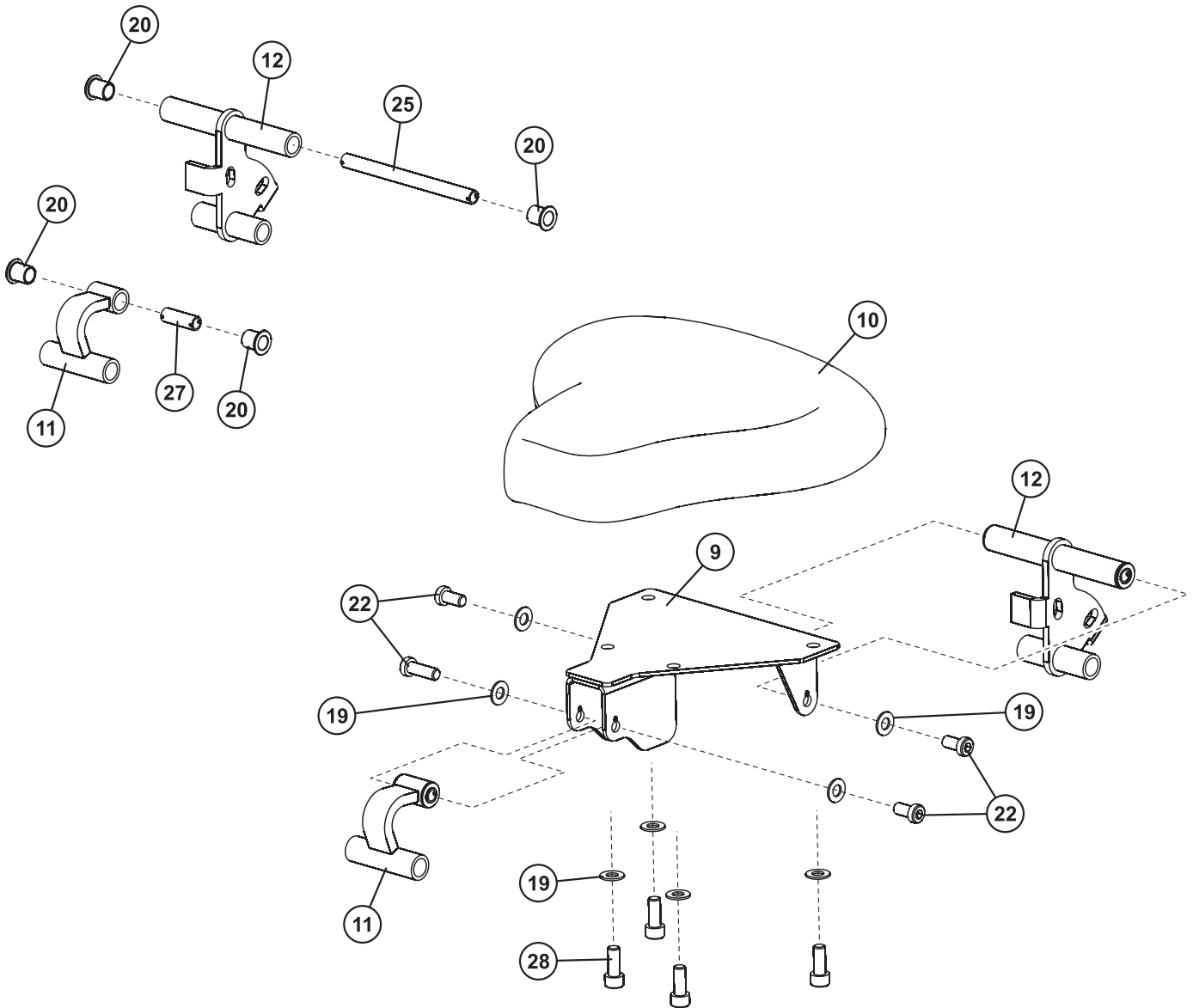

**STEP 5:**

- ❑ Insert two 1/2" x 1/2" BUSHINGS (20) into the top ends of the SEAT ADJUSTMENT ASSEMBLY (12). Insert the 1/2" x 6" SLOTTED SHAFT (25) through the 1/2" x 1/2" BUSHINGS (20).
- ❑ Insert two 1/2" x 1/2" BUSHINGS (20) into the top ends of the SEAT PIVOT BAR (11). Insert the 1/2" x 1 1/2" SLOTTED SHAFT (27) through the 1/2" x 1/2" BUSHINGS (20).
- ❑ Attach the top of the SEAT ADJUSTMENT ASSEMBLY (12) to the SEAT SUPPORT PLATE (9) as shown using two M10 x 20mm SCREWS (22) and two FLAT 3/8" WASHERS (19). Tighten the screws securely.
- ❑ Attach the top of the SEAT PIVOT BAR (11) to the SEAT SUPPORT PLATE (9) as shown using two M10 x 20mm SCREWS (22) and two FLAT 3/8" WASHERS. Tighten the screws securely.
- ❑ Attach the SEAT PAD (10) to the SEAT SUPPORT PLATE (9) using four M10 x 25mm SCREWS (28) and four FLAT 3/8" WASHERS (19) as shown. Tighten the screws securely. Do not overtighten the screws.

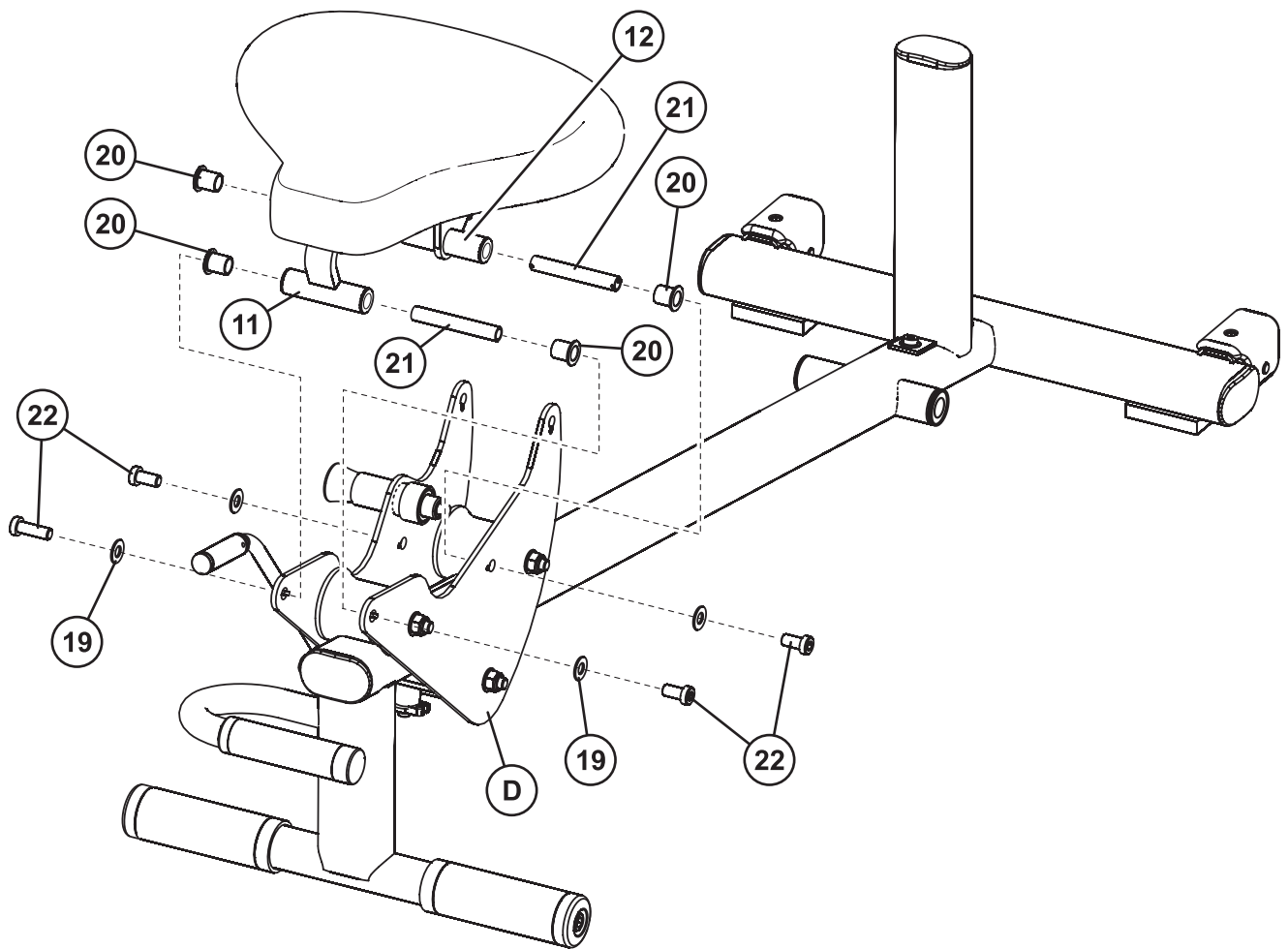

**STEP 6:**

- ❑ Insert two 1/2" x 1/2" BUSHINGS (20) into the bottom ends of the SEAT ADJUSTMENT ASSEMBLY (12). Insert the 1/2" x 3 1/4" SHAFT (21) through the 1/2" x 1/2" BUSHINGS (20).
- ❑ Insert two 1/2" x 1/2" BUSHINGS (20) into the bottom ends of the SEAT PIVOT BAR (11). Insert the 1/2" x 3 1/4" SHAFT (21) through the 1/2" x 1/2" BUSHINGS (20).
- ❑ Attach the SEAT ADJUSTMENT ASSEMBLY (12) and the SEAT PIVOT BAR (11) to the ROLLER CARRIAGE ASSEMBLY (D) using four M10 X 20mm SCREWS (22) and four FLAT 3/8" WASHERS (19). Tighten the screws securely.

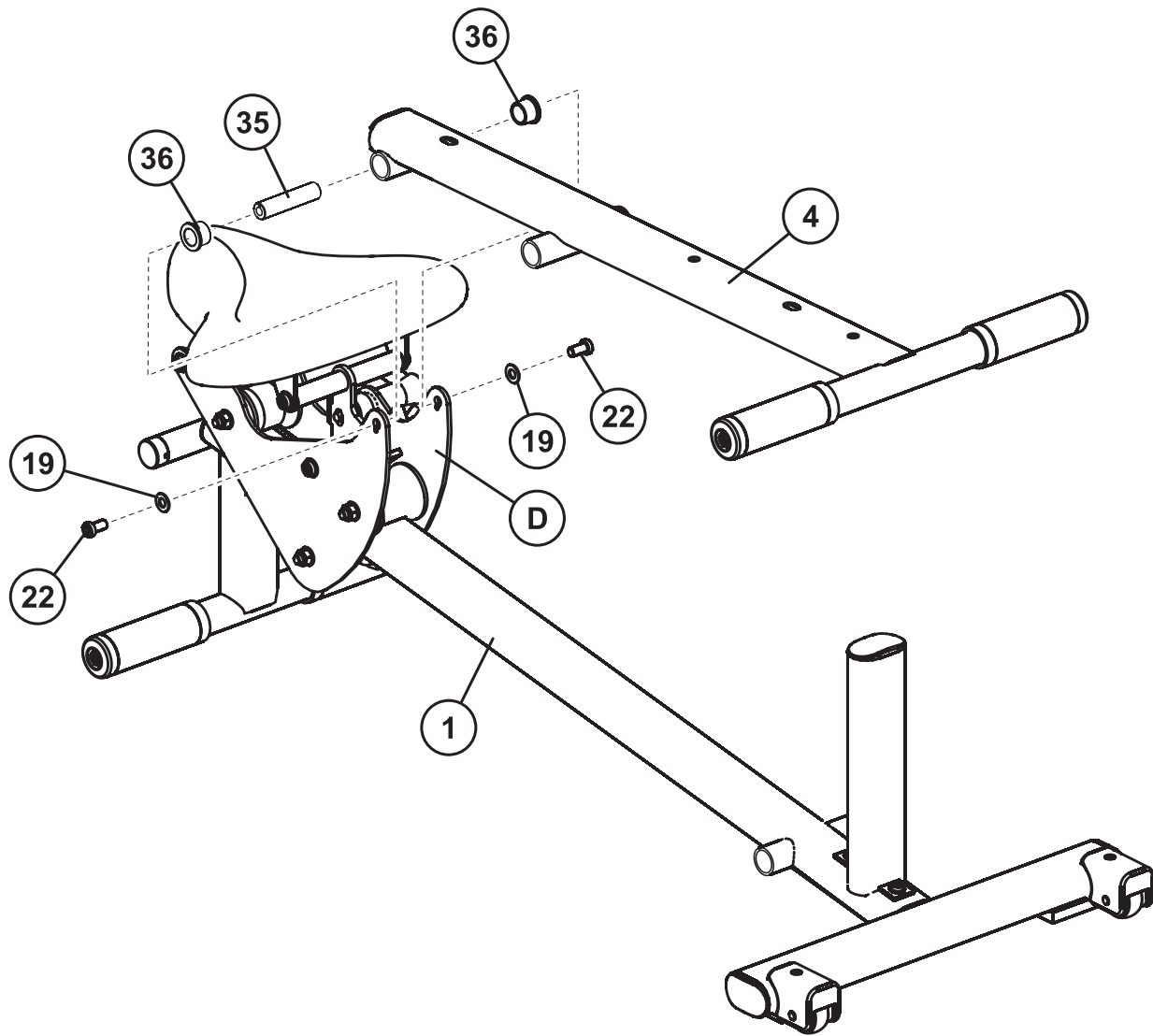

**STEP 7:**

- Insert two 3/4" x 1" BUSHINGS (36) to the ends of the PAD HOLDER ASSEMBLY (4). Insert the 1/2" x 3 1/4" SHAFT (35) through the 3/4" x 1" BUSHINGS (36).
- Position the PAD HOLDER ASSEMBLY (4) onto the MAIN FRAME ASSEMBLY (1) as shown.
- Secure the PAD HOLDER ASSEMBLY (4) to the ROLLER CARRIAGE ASSEMBLY (D) using two M10 x 20mm SCREWS (22) and two FLAT 3/8" WASHERS (19). Tighten the screws securely.

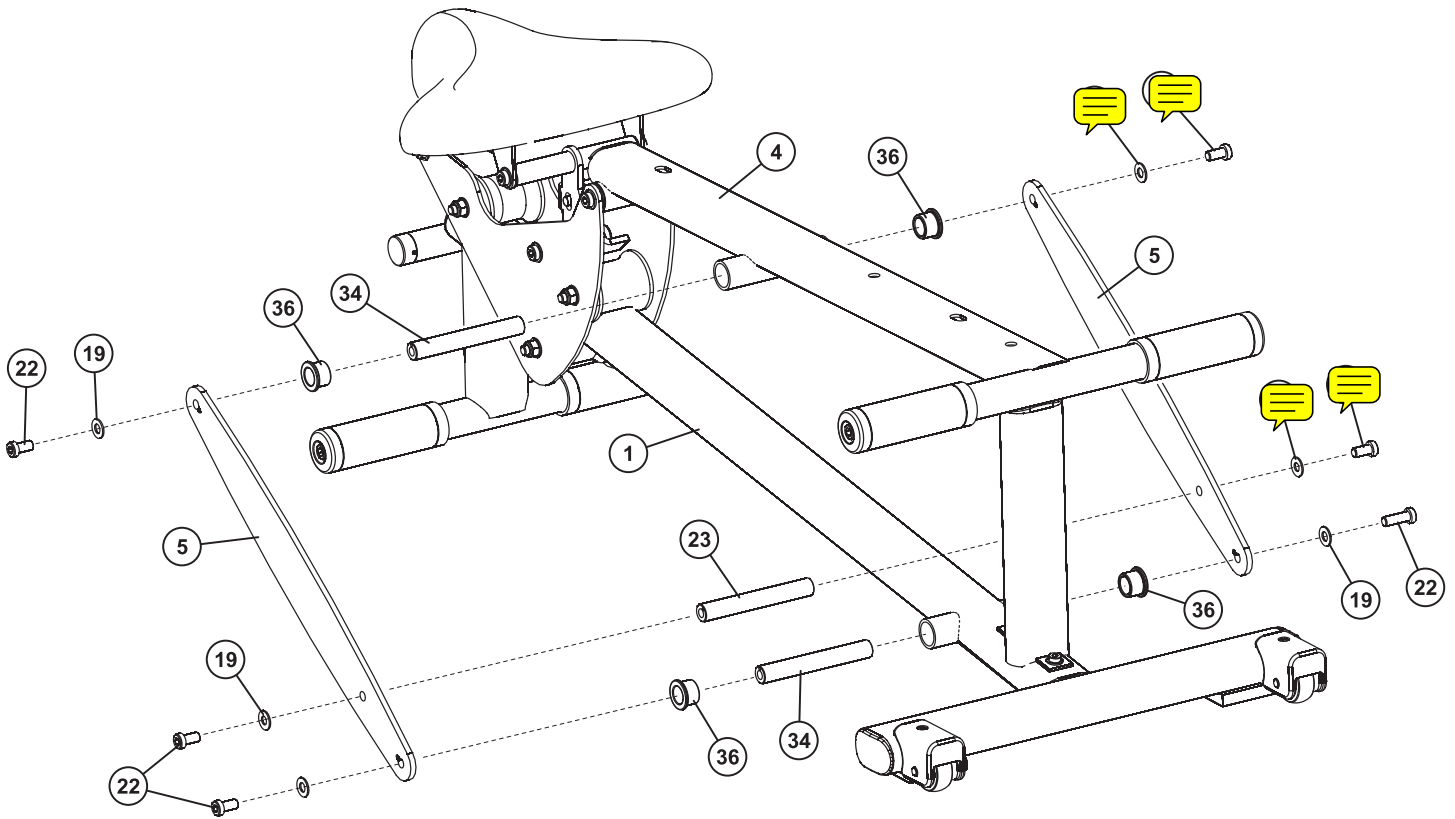

**STEP 8:**

- ❑ Insert two 3/4" x 1" BUSHINGS (36) to the of the PAD HOLDER ASSEMBLY (4). Insert one 1/2" x 5.29" SHAFT (35) through the 3/4" x 1" BUSHINGS (36).
- ❑ Insert two 3/4" x 1" BUSHINGS (36) to the ends of the MAIN FRAME ASSEMBLY (1). Insert the remaining 1/2" x 5.29" SHAFT (35) through the 3/4" x 1" BUSHINGS (36).
- ❑ Attach the BACKREST SUPPORTS (5) to the MAIN FRAME ASSEMBLY (1) and the PAD HOLDER ASSEMBLY (4) using two M10 x 20mm SCREWS (22) and two FLAT 3/8" WASHERS (19) each. Finger tighten the screws.

**NOTE: THE BACKREST SUPPORTS (5) SHOULD BE ORIENTED TOWARDS THE MAIN FRAME ASSEMBLY (1) AS SHOWN.**

- ❑ Attach the BACKREST SUPPORT BRACE (23) between the BACKREST SUPPORTS (5) using two M10 x 20mm SCREWS (22) and two FLAT 3/8" WASHERS (19). Tighten all screws securely.

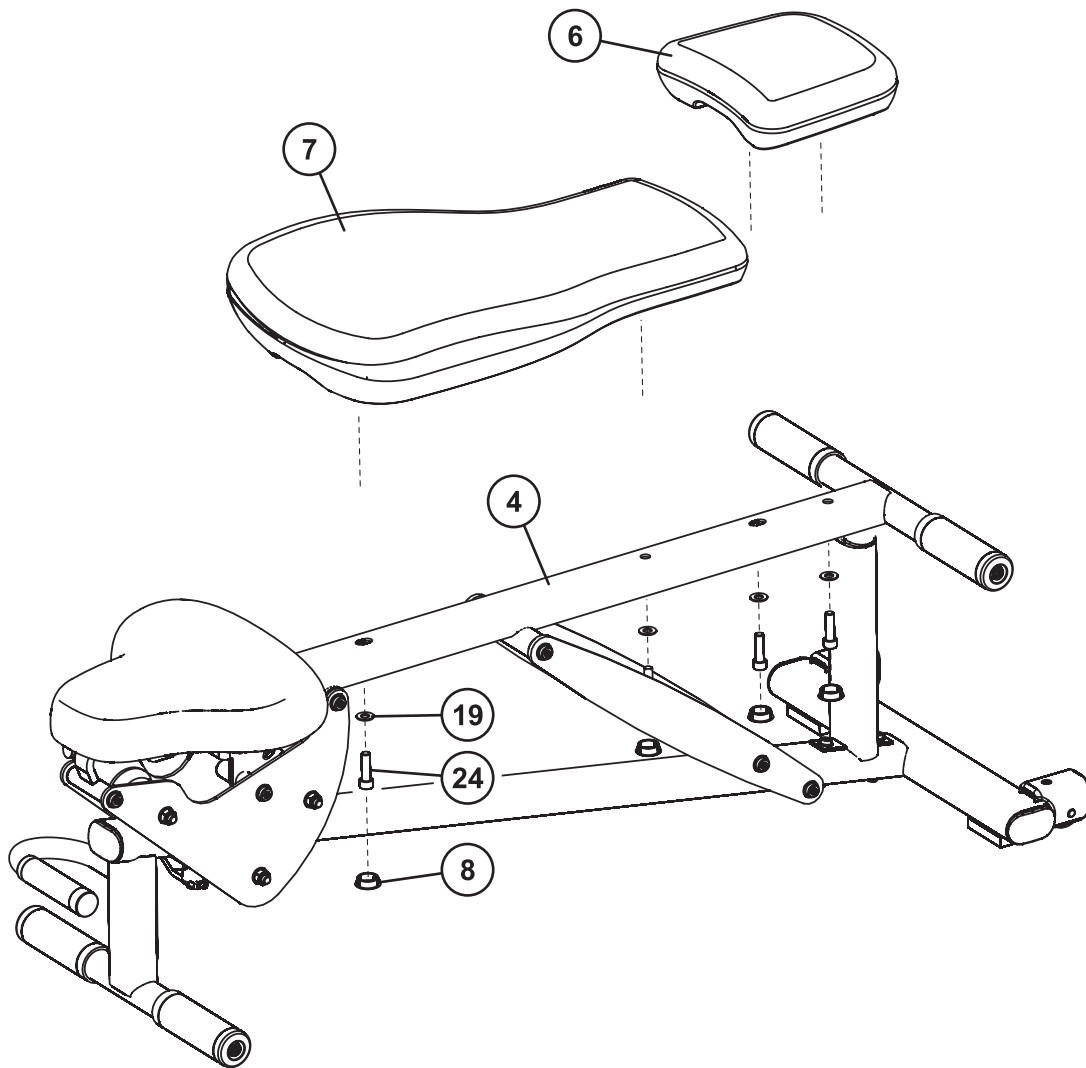

**STEP 9:**

- Attach the BACK PAD (7) to the PAD HOLDER ASSEMBLY (4) as shown using two M10 x 35mm SCREWS (24) and two FLAT 3/8" WASHERS (19). Tighten the screws securely. Do not overtighten the screws.
- Attach the HEADREST PAD (6) to the PAD HOLDER ASSEMBLY (4) as shown using two M10 x 35mm SCREWS (24) and two FLAT 3/8" WASHERS (19). Tighten the screws securely. Do not overtighten the screws.
- Insert HOLE PLUGS (8) into the four access holes underneath the PAD HOLDER ASSEMBLY (4).

# MAINTENANCE

## Please note:

- \* We recommend cleaning your product (pads and frame) on a regular basis, using warm soapy water. Touch-up paint can be purchased from your Life Fitness customer service representative at (800) 351-3737.
- \* Inspect equipment daily. Tighten all loose connections and replace worn parts immediately. Failure to do so may result in serious injury.
- \* **PLEASE RECORD THE INFORMATION REQUESTED BELOW. IN THE EVENT YOU MAY NEED SERVICE YOU WILL BE ASKED FOR THIS INFORMATION. REMEMBER TO FILL OUT YOUR WARRANTY REGISTRATION CARD ON-LINE AT [WWW.LIFEFITNESS.COM](http://WWW.LIFEFITNESS.COM).**

Model #: \_\_\_\_\_

Serial #'s: \_\_\_\_\_

**Note:** *The Model/Serial Number label is located under the MAIN FRAME ASSEMBLY.*

Date of Purchase: \_\_\_\_\_

Dealer's Name \_\_\_\_\_

Dealer's Phone# \_\_\_\_\_

**Thank you for purchasing the Life Fitness  
LFADJ ADJUSTABLE BENCH**

## **LIMITED WARRANTY**

### **Life Fitness® LFADJ-002 BENCH**

Life Fitness extends the following LIMITED WARRANTY to the original owner (proof of purchase required, keep your receipt with this manual) of the Life Fitness product. The Warranty terms apply to IN HOME and LIGHT INSTITUTIONAL USE ONLY.

1. **LIMITED WARRANTY ON FRAME AND WELDS.** If the frame of the Life Fitness product or a weld should crack or break, it will be repaired or replaced by Life Fitness. Terms: IN HOME USE ONLY: Lifetime – for so long as the Customer owns the Life Fitness product; LIGHT INSTITUTIONAL USE: Ten (10) years.
2. **LIMITED WARRANTY ON PARTS.** If the following parts are defective in material or workmanship, Life Fitness will supply replacement parts: all bolts, nuts, washers, bearings, bushings, pulleys, thumbscrews, collars, cable retaining clips, adjustable pre-stretch slides, roller pad shafts, allen head bolts, weight selector pin, weight stack shaft, set screws, protector caps, adjustment chain, cotter pin, plunger, spring and knob. Terms: IN HOME USE ONLY: Lifetime – for so long as the Customer owns the Life Fitness product; LIGHT INSTITUTIONAL USE: One (1) year.
3. **LIMITED WARRANTY ON CABLES AND UPHOLSTERY.** If the coated cables or upholstery are defective in material or workmanship, Life Fitness will repair or replace them, at its option. Terms: IN HOME USE ONLY: Three (3) years; LIGHT INSTITUTIONAL USE: Ninety (90) days.
4. **CONDITIONS AND EXCEPTIONS.** Any product misuse, abuse or alteration, any attempt to repair by a person other than an authorized Life Fitness Service Center, any improper assembly, accident, or any other condition resulting from occurrences beyond the control of Life Fitness will void this Limited Warranty.
5. **REPLACEMENT AND REPAIR EXPENSES.** Life Fitness will provide only replacement parts or repair under this warranty. The Owner is responsible for all other costs. Such costs may include, but are not limited to: a. labor charges for service, removal, repair or reinstallation of the Life Fitness product or any component part; b. shipping, delivery, handling and administrative charges for returning parts to Life Fitness; and c. all necessary or incidental costs related to installation of the replacement parts.
6. **SHIPPING.** If shipping by the Owners is deemed necessary (in sole discretion of Life Fitness), parts should be shipped in their original carton or equivalent packaging, fully insured with shipping charges prepaid. Life Fitness will not assume any responsibility for any loss or damage incurred in shipping.
7. **CLAIM PROCEDURES.** If service on your Life Fitness product is required during the warranty period, please contact our Customer Service Department at 1-800-351-3737 (U.S. and Canada) or +1-847-288-3300 (outside of U.S. and Canada) for instructions regarding returning or replacing parts. Please have available the following information: (i) the dealer's name; (ii) the date of purchase; (iii) the serial # (s) of your product(s) (the serial number location is called out on the final assembly drawing included with your assembly instruction); (iv) a description of the nature of the problem.
8. **OWNER'S RIGHT.** This Limited Warranty gives you specific legal rights. You may also have other rights, which vary depending on local law.
9. **LIMITATION OF IMPLIED WARRANTIES.** All implied warranties, except to the extent prohibited by applicable law, shall have no greater duration than the warranty period set forth above. There are no warranties which extend beyond the description in this Limited Warranty. Because local laws do not allow limitations on how long an implied warranty lasts, the above limitations may not apply to you.
10. **DISCLAIMER.** No other express warranty has been made or will be made on behalf of Life Fitness with respect to any Life Fitness product or the operation, repair or replacement of any Life Fitness product. Life Fitness shall not be responsible for injury, loss of use of the Life Fitness product, inconvenience, loss or damage to personal property, whether direct or indirect, and incidental or consequential damages, so the above limitation or exclusion may not apply to you.

### **Notes:**



## **LIFE FITNESS**

5100 NORTH RIVER ROAD.

SCHILLER PARK, IL 60176 U.S.A.

Tel: 1.847.288.3300 Fax: 1.800.216.8893

1.800.351.3737 (Toll-free within the U.S. and Canada)

[www.lifefitness.com](http://www.lifefitness.com)

### **INTERNATIONAL OFFICES**

Life Fitness Atlantic BV  
Atlantic Headquarters  
Bijdorpplein 25-31  
2992 LB Barendrecht  
The Netherlands  
Phone: (180) 646 666  
Fax: (180) 646 703

Life Fitness (UK) Ltd.  
Queen Adelaide  
Ely, Cambs CB7 4UB  
United Kingdom  
Phone CSS: (01353) 665507  
Fax CSS: (01353) 666719

Life Fitness EUROPE GmbH  
Siemensstrasse 3  
85716 Unterschleissheim  
Germany  
Phone: (089) 31 77 51-0  
Fax: (089) 31 77 51 99

Life Fitness Benelux N.V.  
Bijdorpplein 25-31  
2992 LB Barendrecht  
The Netherlands  
Phone: 31 (180) 64 66 69  
Fax: 31 (180) 64 66 99

Life Fitness Italia S.R.L.  
Via Crivellin 7/N  
37010 Affi Verona  
Italy  
Phone: 39 (457) 237811  
Fax: 39 (457) 238197

Life Fitness Japan  
8/F, Nippon Brunswick Building  
5-27-7 Sendagaya  
Shibuya-Ku, Tokyo 151-0051  
Japan  
Phone: 81 (3) 3359-4309  
Fax: 81 (3) 3359-4307

Life Fitness Asia Pacific Limited  
Room 2610, Miramar Tower  
132 Nathan Road, Tsimshatsui  
Kowloon, Hong Kong  
Phone: (852) 2891-6677  
Fax: (852) 2575-6001

Life Fitness Do Brazil  
Al. Rio Negro, 433-Predio 2-Sala 2  
3° andar (Confab)  
Aphaville-Barueri-Sao Paulo  
CEP: 06454-904  
Brazil  
Phone: 55 (11)7295-2217  
Fax: 55 (11) 7295-2218