

Life Fitness

WT. STACK SHROUD FOR GS5

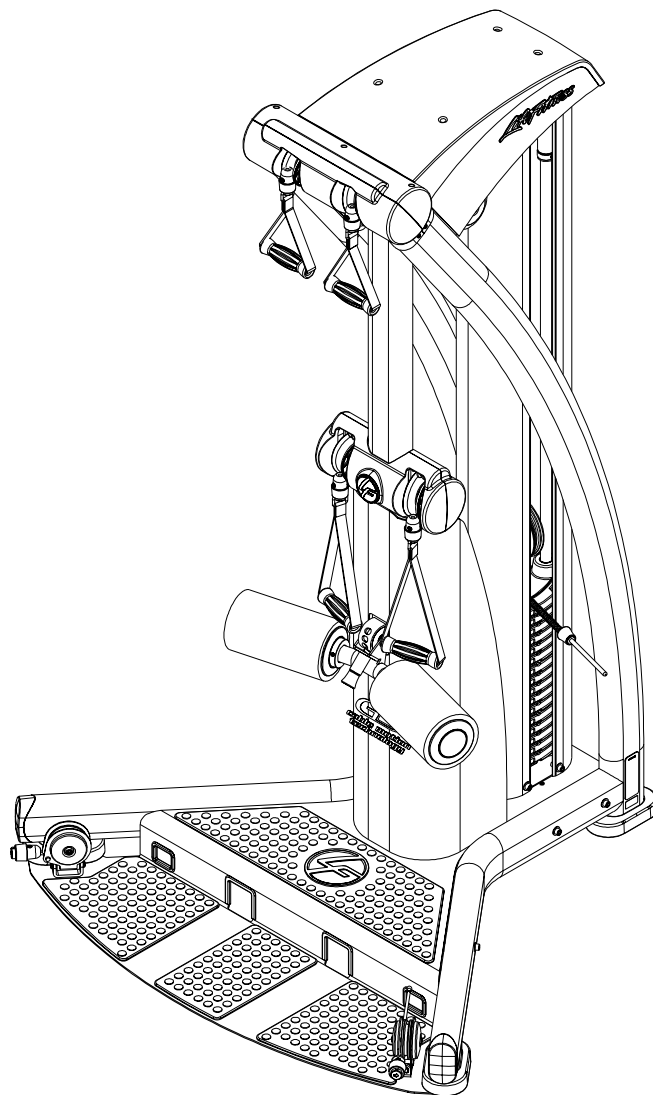

WARNING:

Read and follow all directions for each step to insure proper assembly of this product.

USER GUIDE

CLASSH
PART # 7822601 REV.A
VERSION: LFG5-SHR-101
DATE: 01-06-05

TABLE OF CONTENTS

Safety Statement.....	2	Assembly Instructions.....	4-8
General Notes.....	2	General Maintenance.....	9
Components List.....	3	Warranty Statement.....	10
Exploded View.....	3	Contact Information.....	11
Tool Requirements and Hardware.....	3		

IMPORTANT SAFETY INFORMATION



THERE IS A RISK ASSUMED BY INDIVIDUALS WHO USE THIS TYPE OF EQUIPMENT. TO MINIMIZE RISK FOLLOW THESE RULES!

1. Before using, read all the warnings and instructions on the use of this machine including the wall chart and instructional DVD. Use only for intended exercise. **DO NOT** modify the machine.
2. Obtain a medical exam before beginning any exercise program.
3. Keep body and clothing free of all moving objects.
4. Inspect the machine before use. **DO NOT** use it if it appears damaged. **DO NOT** attempt to fix a broken or jammed machine. Notify your authorized Life Fitness dealer before use and have repairs made by an authorized service technician.
5. Be certain that weight pin is completely inserted. Use only the pin provided by the manufacturer. If unsure, call your authorized Life Fitness dealer.
6. Never pin the weights or prop plate into an elevated position. **DO NOT** use the machine if found in this condition. **DO NOT** attempt to fix. Notify your authorized Life Fitness dealer.
7. Inspect cables and their connections before using machine. Pay particular attention to the cable ends. **DO NOT** attempt to fix. Notify your authorized Life Fitness dealer before use and have repairs made by an authorized service technician.
8. Make sure all spring loaded pull pins are fully engaged in the adjustment position before use.
9. Children and pets must not be allowed near this machine. Supervise teenagers.

Please note:

- * Thank you for purchasing the Life Fitness Weight Stack Shroud for G5. Please read these instructions thoroughly and keep them for future reference. This product must be assembled on a flat, level surface to assure its proper function.
- * **DO NOT** securely tighten any frame connections until the entire frame has been assembled, unless otherwise stated.

NOTE: In a continual effort to improve our products, specifications are subject to change

© 2004 Life Fitness, a division of Brunswick Corporation. All rights reserved.

Life Fitness is a trademark of Brunswick Corporation

COMPONENTS LIST

ITEM NO.	QTY.	PART NO.	DESCRIPTION
1	2	LEA7801595	SHROUD, G5 WEIGHT STACK
2	1	LEA7822495	PTD ASSY, SHROUD BRACKET TOP
3	1	LEA7822595	PTD ASSY, SHROUD BRACKET BOTTOM
4	8	LEA3249203	3/8-16 X 3/4 CAP SCREW
5	2	LEA3249216	3/8-16 X 3-3/4" CAP SCREW
6	8	LEA3102514	3/8" SAE WASHER
7	1	LEA7822101	ASSY INSTRUCTIONS
8	1	LEA7777201	WARRANTY CARD

REQUIRED TOOLS:

- * 9/16" wrench
- * 8mm Allen wrench
- * 4 mm Allen wrench
- * 3/4 Wrench
- * Phillips Screw Driver

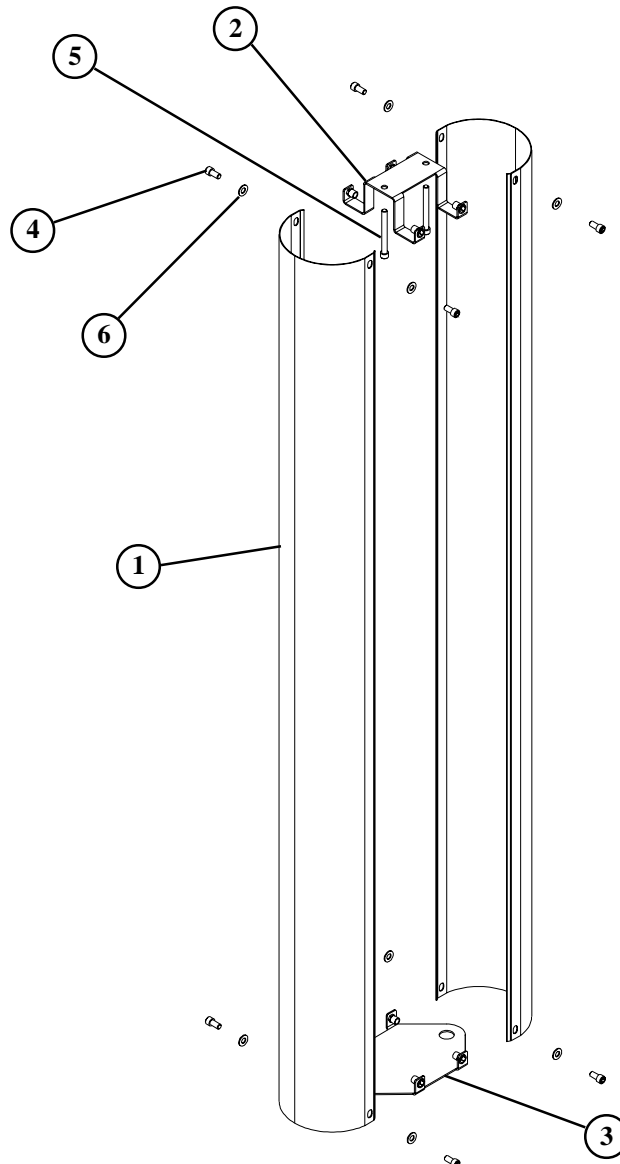

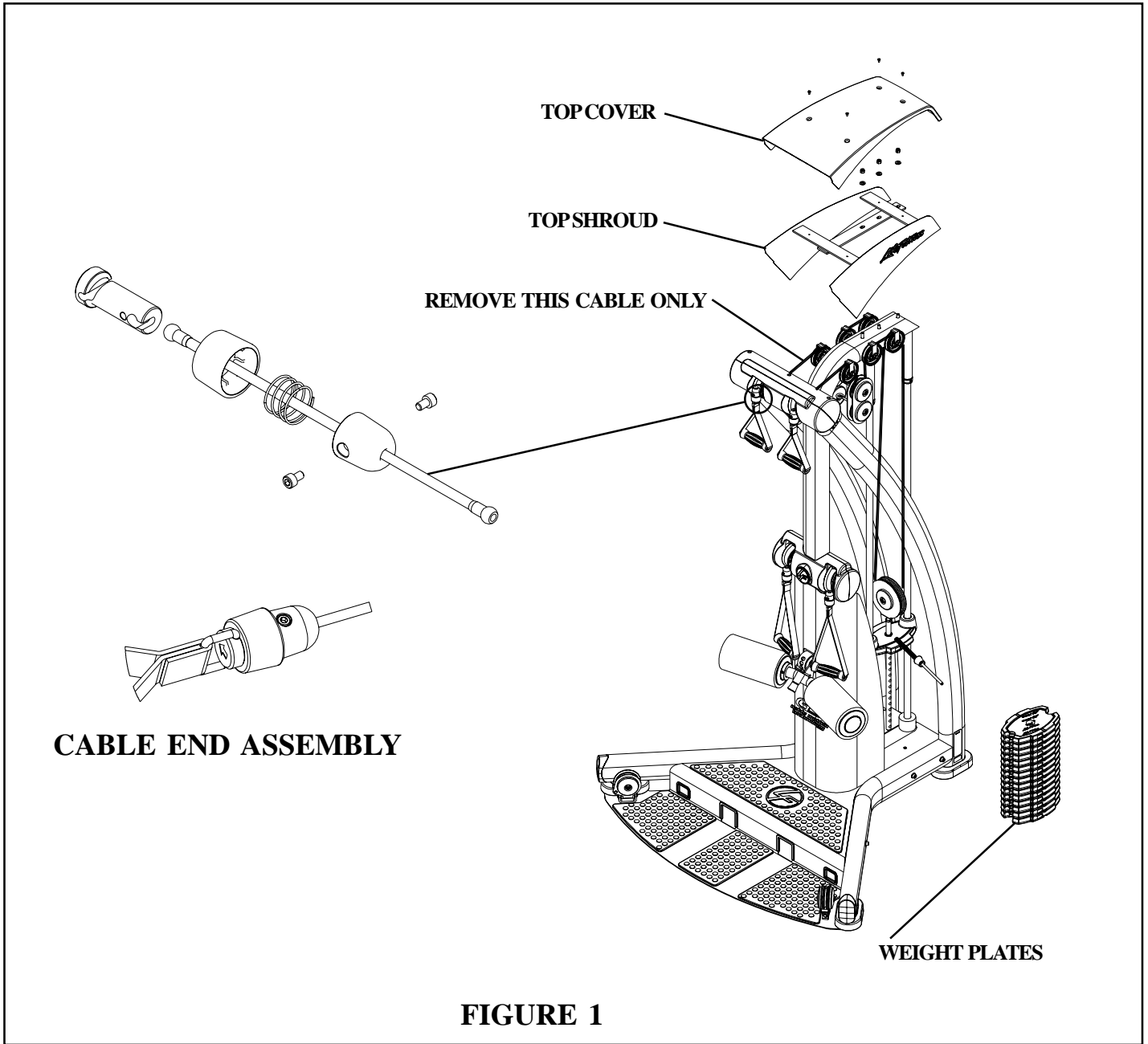
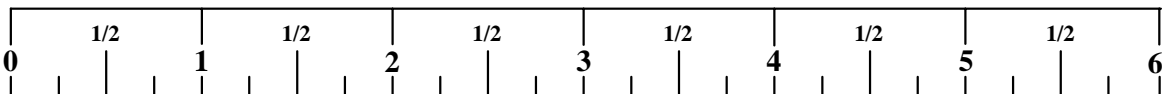

FIGURE 1

STEP 1:

- ❑ Disassemble one cable end and remove cable.
- ❑ Remove TOP COVER and TOP SHROUD from machine.
- ❑ Remove WEIGHT PLATES.



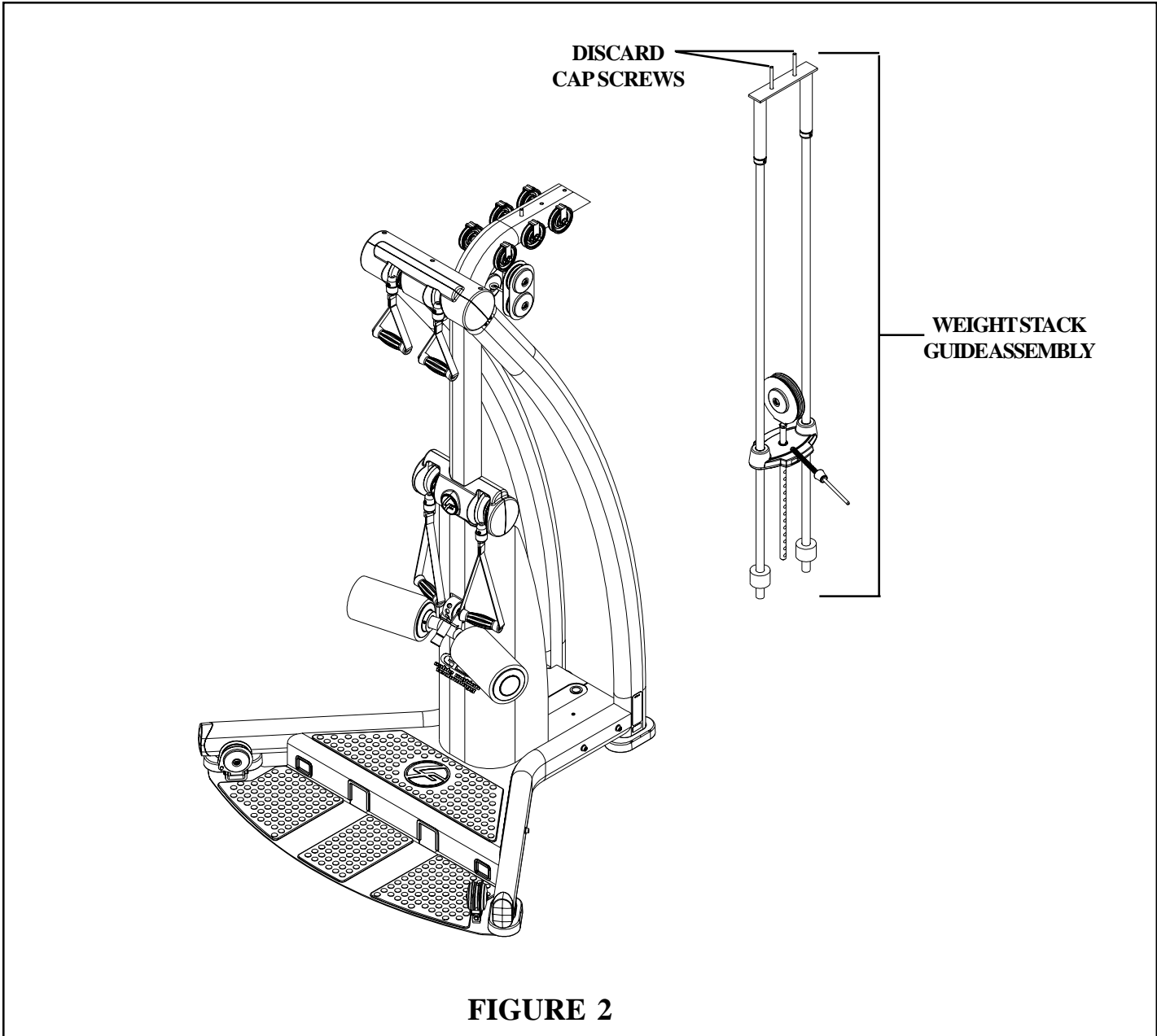

FIGURE 2

STEP 2:

- ❑ Remove entire WEIGHT PLATE GUIDE ASSEMBLY AS SHOWN IN FIGURE ABOVE.
- ❑ Discard CAP SCREWS shown above

NOTE:

YOU WILL NEED TO RE-ASSEMBLE. THEREFORE, IT IS IMPORTANT THAT YOU REMEMBER THE PROPER ORDER OF ALL COMPONENTS AS SHOWN.

IF NEED BE REFER TO G5 CABLE MOTION GYM SYSTEM MANUAL FOR DETAILED ASSEMBLY !!

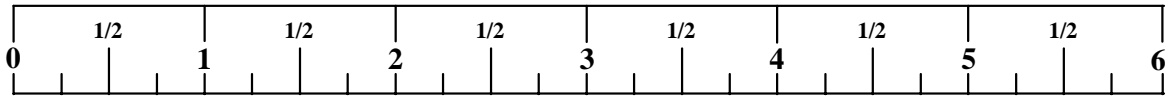

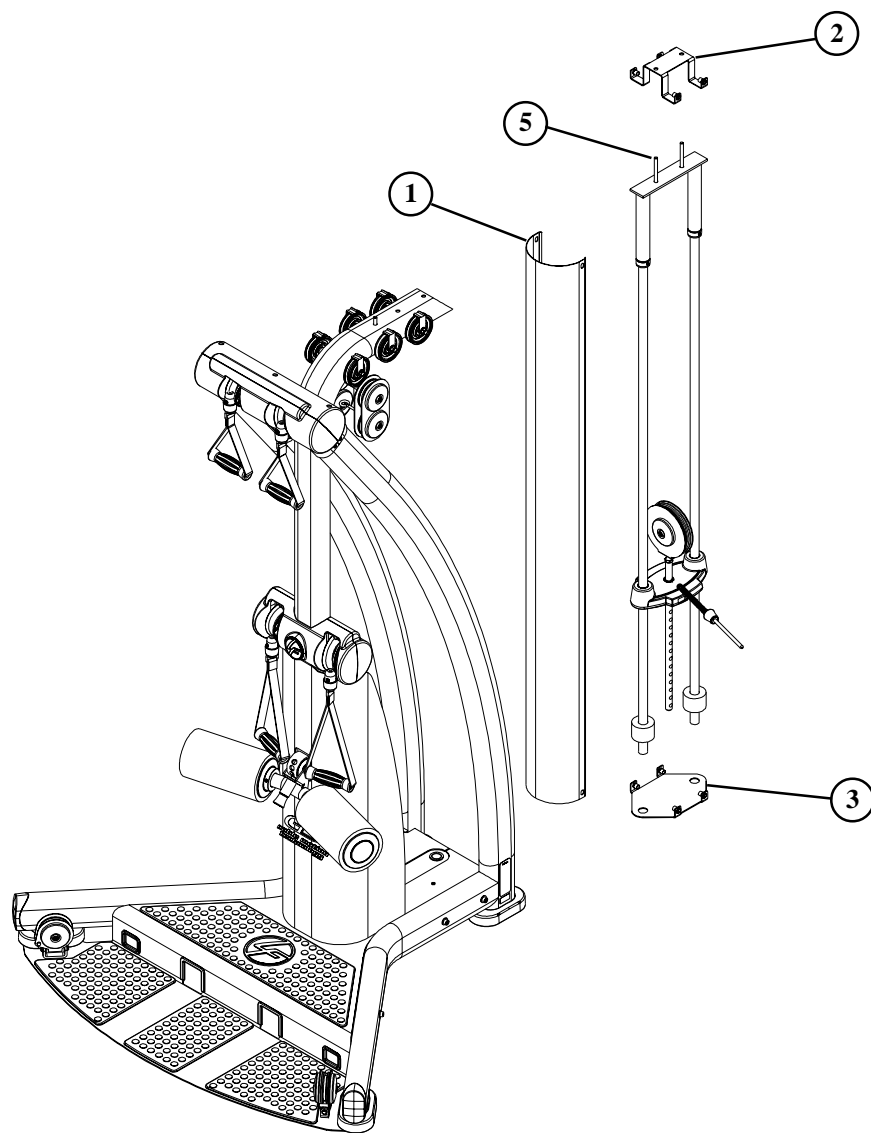

FIGURE 3

STEP 3:

- ❑ Slide one SHROUD (1) into back of machine and slide forward to make room for WEIGHT PLATE and GUIDE ASSEMBLY.
- ❑ Place BOTTOM SHROUD BRACKET (3) on G5 BASE.
- ❑ Re-install WEIGHT GUIDE ASSY. Including new SHROUD BRACKETS, TOP(2) and BOTTOM (3) as shown in figure above.

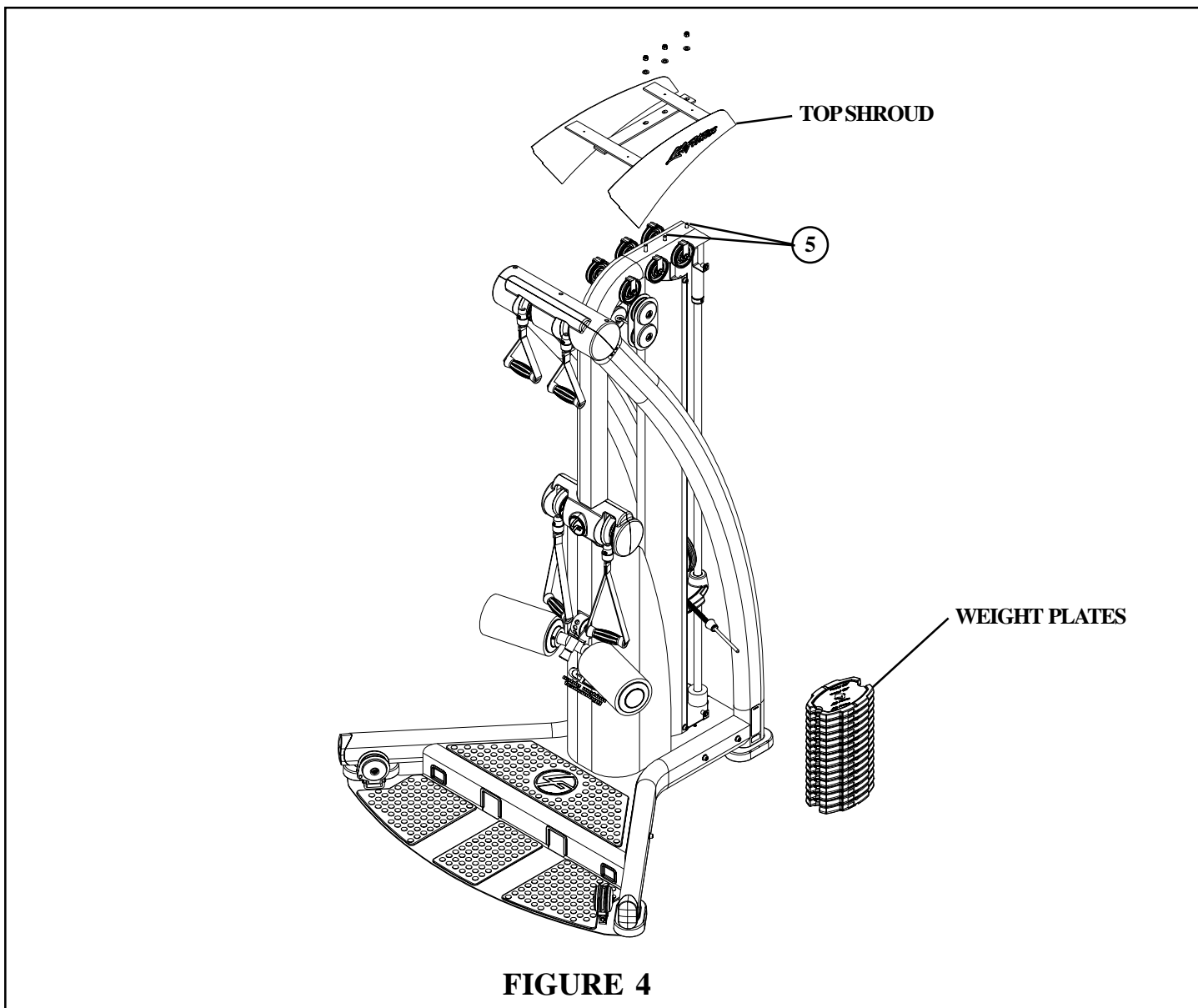

FIGURE 4

STEP 4:

- ❑ Securely assemble TOP SHROUD to gym using two 3/8 X 3-3/4 CAPS SCREWS (5) and the G5 hardware.
- ❑ Re-install CABLE and CABLE END: **REFER TO FIG 1**
- ❑ **CAREFULLY** Slide all WEIGHT PLATES back into position.

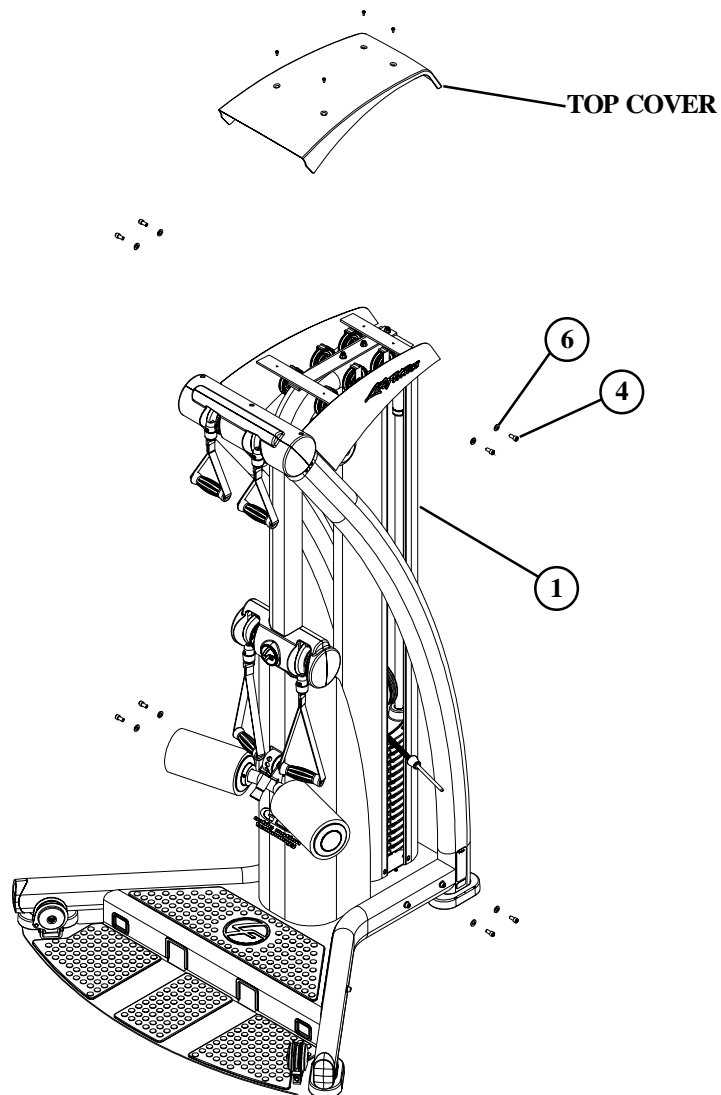

FIGURE 5

STEP 5

- ❑ Place other SHROUD (1) into back of gym as shown above and securely tighten both SHROUDS (1) to TOP SHROUD BRACKET (2) and BOTTOM SHROUD BRACKET (3) using eight 3/8 WASHERS (6) and eight 3/8 X 3/4 CAP SCREWS (4).
- ❑ Place TOP COVER back into position and tighten with screws.

MAINTENANCE

Please note:

- * We recommend cleaning your product (pads and frame) on a regular basis, using warm soapy water. Touch-up paint can be purchased from your Life Fitness customer service representative at (800) 328-9714.(Outside of the U.S. and Canada, +1-847-288-3300)
- * Inspect equipment daily. Tighten all loose connections and replace worn parts immediately. Failure to do so may result in serious injury
- * Insure guide rods are lubricated. Lubricate every six months or as needed

*** PLEASE RECORD THE INFORMATION REQUESTED BELOW. IN THE EVENT YOU MAY NEED SERVICE YOU WILL BE ASKED FOR THIS INFORMATION. REMEMBER TO FILL OUT YOUR WARRANTY REGISTRATION CARD AND MAIL BACK.**

Important Customer Purchase Information:

Model #: _____

Serial #'s: _____

Date of Purchase: _____

Authorized Life Fitness Dealer Purchased from:

Address: _____

Phone: _____

Salesperson: _____

**Thank you for purchasing the Life Fitness
G5 WEIGHT STACK SHROUD**

LIMITED WARRANTY

Life Fitness Weight Stack Shroud G5

Life Fitness extends the following LIMITED WARRANTY to the original owner (proof of purchase required, keep your receipt with this manual) of the Life Fitness product. The Warranty terms apply to IN HOME and LIGHT INSTITUTIONAL USE ONLY.

1. **LIMITED WARRANTY ON FRAME AND WELDS.** If the frame of the Life Fitness product or a weld should crack or break, it will be repaired or replaced by Life Fitness at its option. Repaired or replaced parts are warranted for the remaining portion of the original warranty period. Terms: IN HOME USE ONLY: Lifetime – for so long as the original owner owns the Life Fitness product; LIGHT INSTITUTIONAL USE: Original owner, ten (10) years.
2. **LIMITED WARRANTY ON PARTS.** If the following parts are defective in material or workmanship, Life Fitness will supply replacement parts: all bolts, nuts, washers, bearings, bushings, pulleys, thumbscrews, collars, cable retaining clips, adjustable pre-stretch slides, roller pad shafts, allen head bolts, weight selector pin, weight stack shaft, set screws, protector caps, adjustment chain, cotter pin, plunger, spring and knob. Replacement parts are warranted for the remaining portion of the original warranty period. Terms: IN HOME USE ONLY: Lifetime – for so long as the original owner owns the Life Fitness product; LIGHT INSTITUTIONAL USE: Original owner, one (1) year.
3. **LIMITED WARRANTY ON CABLES AND UPHOLSTERY.** If the coated cables or upholstery are defective in material or workmanship, Life Fitness will repair or replace them, at its option. Repaired or replaced parts are warranted for the remaining portion of the original warranty period. Terms: IN HOME USE ONLY: Original owner, three (3) years; LIGHT INSTITUTIONAL USE: Original owner, ninety (90) days.
4. **DEFINITION OF APPLICATIONS:** IN HOME USE ONLY applies to the product being used solely in a single family residential setting used by a single family for family use only and not for professional training. LIGHT INSTITUTIONAL USE refers to the product being used in an application where multiple users have access to the product with no more than six hours of continual use on a daily basis. Such usage can include applications such as municipalities, small personal training studios, specialty athletic training studios, multiple housing, corporate fitness facilities, hospitality.
5. **CONDITIONS AND EXCEPTIONS.** Any product misuse, abuse, negligence, alteration or modification without Life Fitness' written authorization, any attempt to repair by a person other than an authorized Life Fitness Service Center, any improper assembly or installation, accident, debris resulting from any construction activities on the premises where the product is located, rust or corrosion, failure on the Owner's part to use, operate and maintain the product as set out in the product's operation manual, or any other condition resulting from occurrences beyond the control of Life Fitness will void this Limited Warranty. THIS WARRANTY MAY VARY OR BE VOID (AT LIFE FITNESS' OPTION) FOR PRODUCTS SHIPPED OUTSIDE OF THE UNITED STATES.
6. **REPLACEMENT AND REPAIR EXPENSES.** Life Fitness will provide only replacement parts or repair under this warranty. The Owner is responsible for all other costs. Such costs may include, but are not limited to: a. labor charges for service, removal, repair or reinstallation of the Life Fitness product or any component part; b. shipping, delivery, handling and administrative charges for returning parts to Life Fitness; and c. all necessary or incidental costs related to installation of the replacement parts.
7. **SHIPPING.** If shipping by the Owners is deemed necessary (in sole discretion of Life Fitness), parts should be shipped in their original carton or equivalent packaging, fully insured with shipping charges prepaid. Life Fitness will not assume any responsibility for any loss or damage incurred in shipping.
8. **CLAIM PROCEDURES.** If service on your Life Fitness product is required during the warranty period, please contact our Customer Service Department at 1-800-328-9714 (U.S. and Canada) or +1-847-288-3300 (outside of U.S. and Canada) for instructions regarding returning or replacing parts. Please have available the following information: (i) the dealer's name; (ii) the date of purchase; (iii) the serial # (s) of your product(s) (the serial number location is called out on the final assembly drawing included with your assembly instruction); (iv) a description of the nature of the problem.
9. **OWNER'S RIGHT.** This Limited Warranty gives you specific legal rights. You may also have other rights, which vary depending on local law.
10. **LIMITATION OF IMPLIED WARRANTIES.** All implied warranties, except to the extent prohibited by applicable law, shall have no greater duration than the warranty period set forth above. There are no warranties which extend beyond the description in this Limited Warranty. Because local laws do not allow limitations on how long an implied warranty lasts, the above limitations may not apply to you.
11. **DISCLAIMER.** No other express warranty has been made or will be made on behalf of Life Fitness with respect to any Life Fitness product or the operation, repair or replacement of any Life Fitness product. Life Fitness shall not be responsible for injury, loss of use of the Life Fitness product, inconvenience, loss or damage to personal property, whether direct or indirect, and incidental or consequential damages, so the above limitation or exclusion may not apply to you.

LIFE FITNESS

5100 NORTH RIVER ROAD.

SCHILLER PARK, IL 60176 U.S.A.

Tel: 1.847.288.3300 Fax: 1.800.216.8893

1.800.328.9714 (Toll-free within the U.S. and Canada)

www.LifeFitness.com

INTERNATIONAL OFFICES

Life FitnessAtlantic BV
Atlantic Headquarters
Bijdorpplein 25-31
2992 LB Barendrecht
The Netherlands
Phone: (180) 646 666
Fax: (180) 646 703

Life Fitness (UK) Ltd.
Queen Adelaide
Ely, Cambs CB7 4UB
United Kingdom
Phone CSS: (01353) 665507
Fax CSS: (01353) 666719

Life Fitness EUROPE GmbH
Siemensstrasse 3
85716 Unterschleissheim
Germany
Phone: (089) 31 77 51-0
Fax: (089) 31 77 51 99

Life Fitness Benelux N.V.
Bijdorpplein 25-31
2992 LB Barendrecht
The Netherlands
Phone: 31 (180) 64 66 69
Fax: 31 (180) 64 66 99

Life Fitness Italia S.R.L.
Via Elvas 92
39042 Bressanone
Italy
Phone: 39 (472) 835-470
Fax: 39 (472) 833-150

Life Fitness Japan
8/F, Nippon Brunswick Building
5-27-7 Sendagaya
Shibuya-Ku, Tokyo 151-0051
Japan
Phone: 81 (3) 3359-4309
Fax: 81 (3) 3359-4307

Life Fitness Asia Pacific Limited
Room 2610, Miramar Tower
132 Nathan Road, Tsimshatsui
Kowloon, Hong Kong
Phone: (852) 2891-6677
Fax: (852) 2575-6001

Life Fitness Do Brazil
Al. Rio Negro, 433-Predio 2-Sala 2
3º andar (Confab)
Aplhaville-Barueri-Sao Paulo
CEP: 06454-904
Brazil
Phone: 55 (11)7295-2217
Fax: 55 (11) 7295-2218