

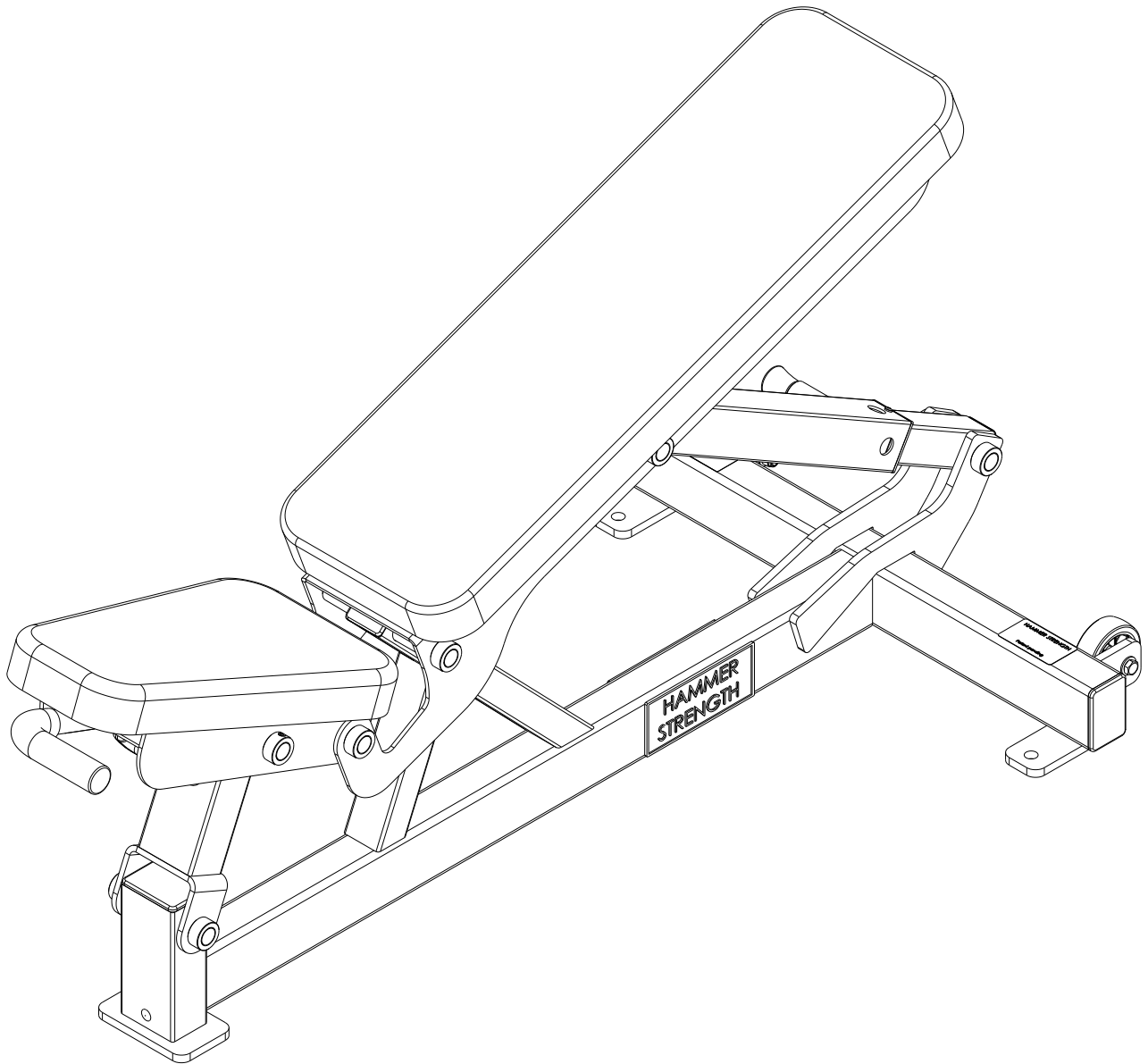

HAMMER STRENGTH
FWMAB
FREE WEIGHT MULTI-ANGLE BENCH



Customer Support Services
PARTS LIST

FWMAB FREE WEIGHT MULTI-ANGLE BENCH CONTENTS

	page
COMPONENT ASSEMBLY	3
COMPONENT ASSEMBLY LEGEND	4
BOTTOM FRAME ASSEMBLY	5
SPRING PIN TUBE ASSEMBLY	6
ADJUSTMENT ASSEMBLY	7
SEAT ASSEMBLY	8
SEAT BACK ASSEMBLY	9

FWMAB FREE WEIGHT MULTI-ANGLE BENCH COMPONENT ASSEMBLY

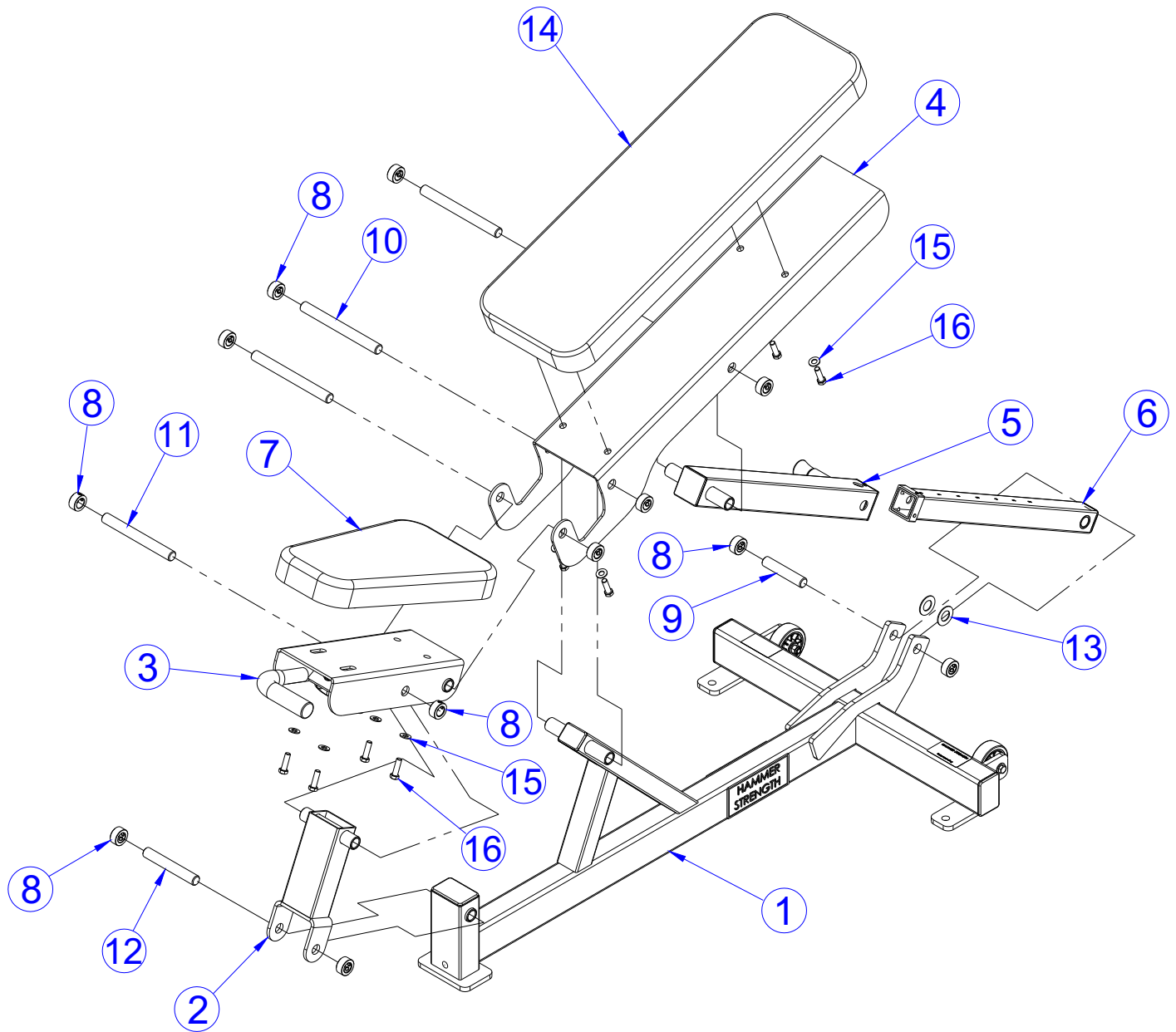

SEE PAGE 4 FOR LEGEND

FWMAB FREE WEIGHT MULTI-ANGLE BENCH COMPONENT ASSEMBLY LEGEND

ITEM NO.	QTY.	PART NO.	DESCRIPTION
1	1	7658501	ASSY, FWMAB BOTTOM FRAME
2	1	7661001	WLDMT, FWMAB FRONT LINK
3	1	7660501	ASSY, FWMAB SEAT
4	1	7661401	ASSY, FWMAB SEAT BACK
5	1	7659801	ASSY, FWMAB SPRING PIN TUBE
6	1	7660201	ASSY, FWMAB ADJ. ASM
7	1	U-FWMAB	BENCH PAD
8	12	3103301	SHAFT COLLAR, 3/4 I.D. ZINC
9	1	8062201	SHAFT, FWMAB, REAR PIVOT
10	3	8062101	SHAFT, FWMAB, MAIN PIVOT
11	1	8062301	SHAFT, FWMAB, FRONT TOP
12	1	8062401	SHAFT, FWMAB, FRONT BOTTOM
13	2	7351001	SPACER, INC WT STACK
14	1	U33-19	STANDARD 33" PAD
15	8	3236601	WASHER, 3/8 SAE SS
16	8	3223302	3/8-16 X 1.25 HEX HEAD BOLT

FWMAB FREE WEIGHT MULTI-ANGLE BENCH BOTTOM FRAME ASSEMBLY - 7658501

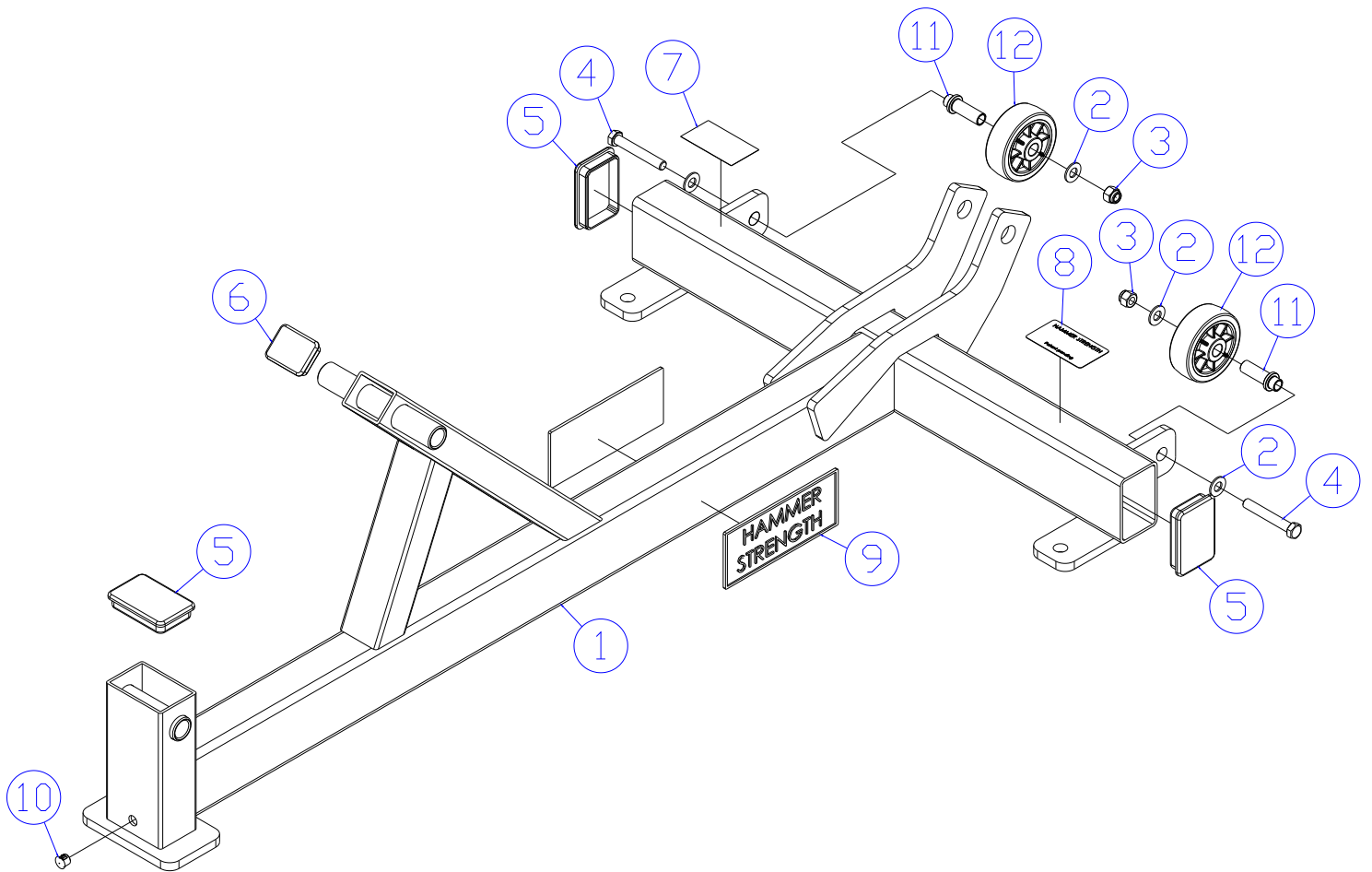

ITEM NO.	QTY.	PART NO.	DESCRIPTION
1	1	7962101	WLDMT, FWMAB BOTTOM FRM
2	4	3236601	WASHER, 3/8 SAE SS
3	2	3102802	NUT, NYLOCK 3/8-16
4	2	3223307	3/8-16 X 2.50 HEX HEAD BOLT
5	3	7352301	CAP, END 2 X 3
6	1	7352201	CAP, END 1-1/2 X 2
7	1	7422003	LABEL, MOVING PARTS
8	1	M051-00299-A000	HAMMER PATENT DECAL
9	2	M051-00289-A000	HAMMER STRENGTH NAME PLATE
10	1	3237401	PLUG, 7/16" HOLE
11	2	7961401	AXLE, FW, WHEEL
12	2	0K59-01164-0000	WHEEL: 3.0 OD X .50 ID OVERMOLD

FWMAB FREE WEIGHT MULTI-ANGLE BENCH SPRING PIN TUBE ASSEMBLY - 7659801

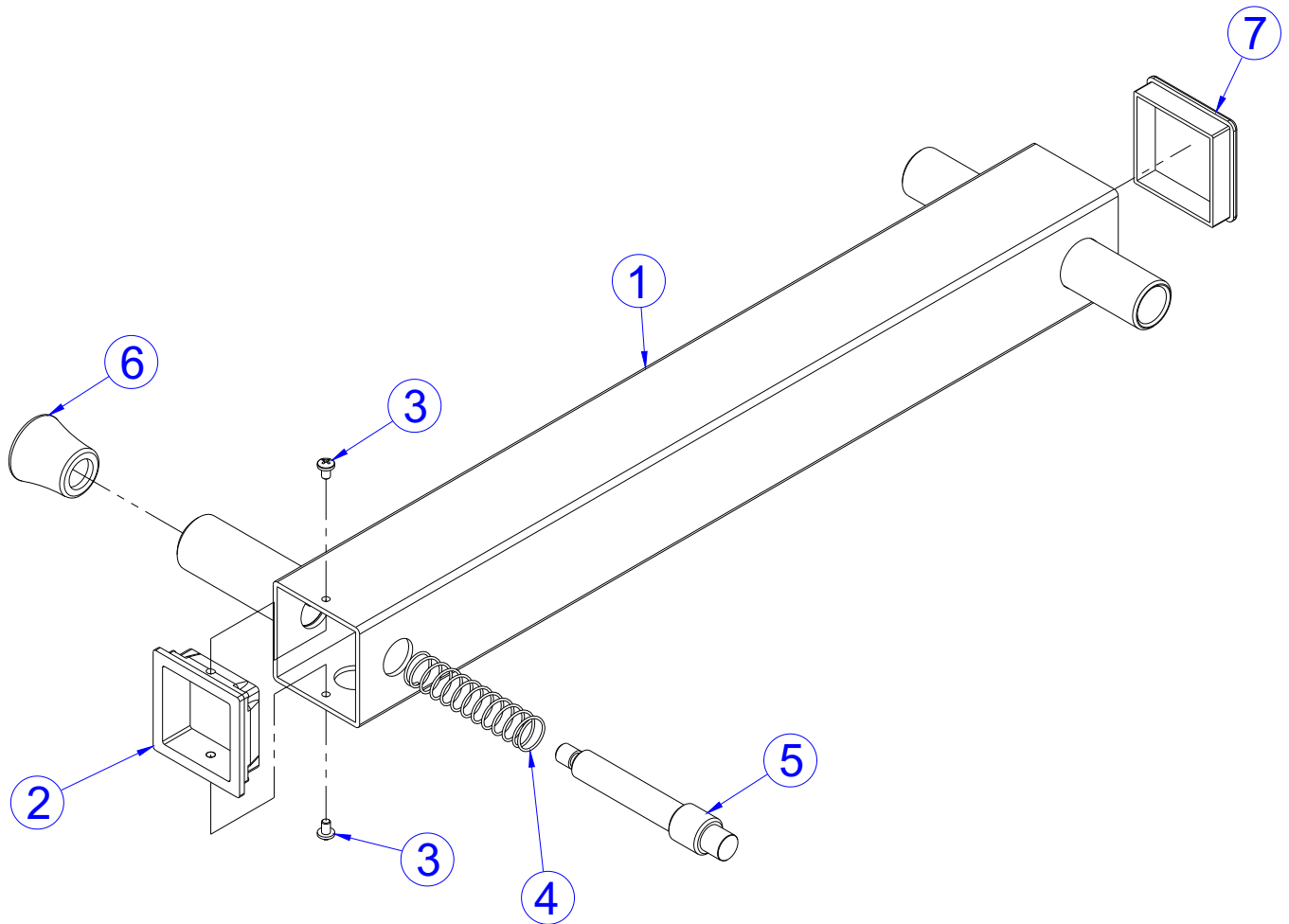

ITEM NO.	QTY.	PART NO.	DESCRIPTION
1	1	7659901	WLDMT, FWMAB ADJ TUBE
2	1	7660101	INSERT: FWMAB PLASTIC SEAT 2 X 2
3	2	3224701	8-32 X 4 PHL PAN TT ST ZN
4	1	7351501	SPRING; PULL PIN LARGE
5	1	7351301	PIN, PULL X 4.375
6	1	7351401	KNOB, TULIP STYLE
7	1	7689901	CAP, END 2.25 X 2.25

FWMAB FREE WEIGHT MULTI-ANGLE BENCH ADJUSTMENT ASSEMBLY - 7660201

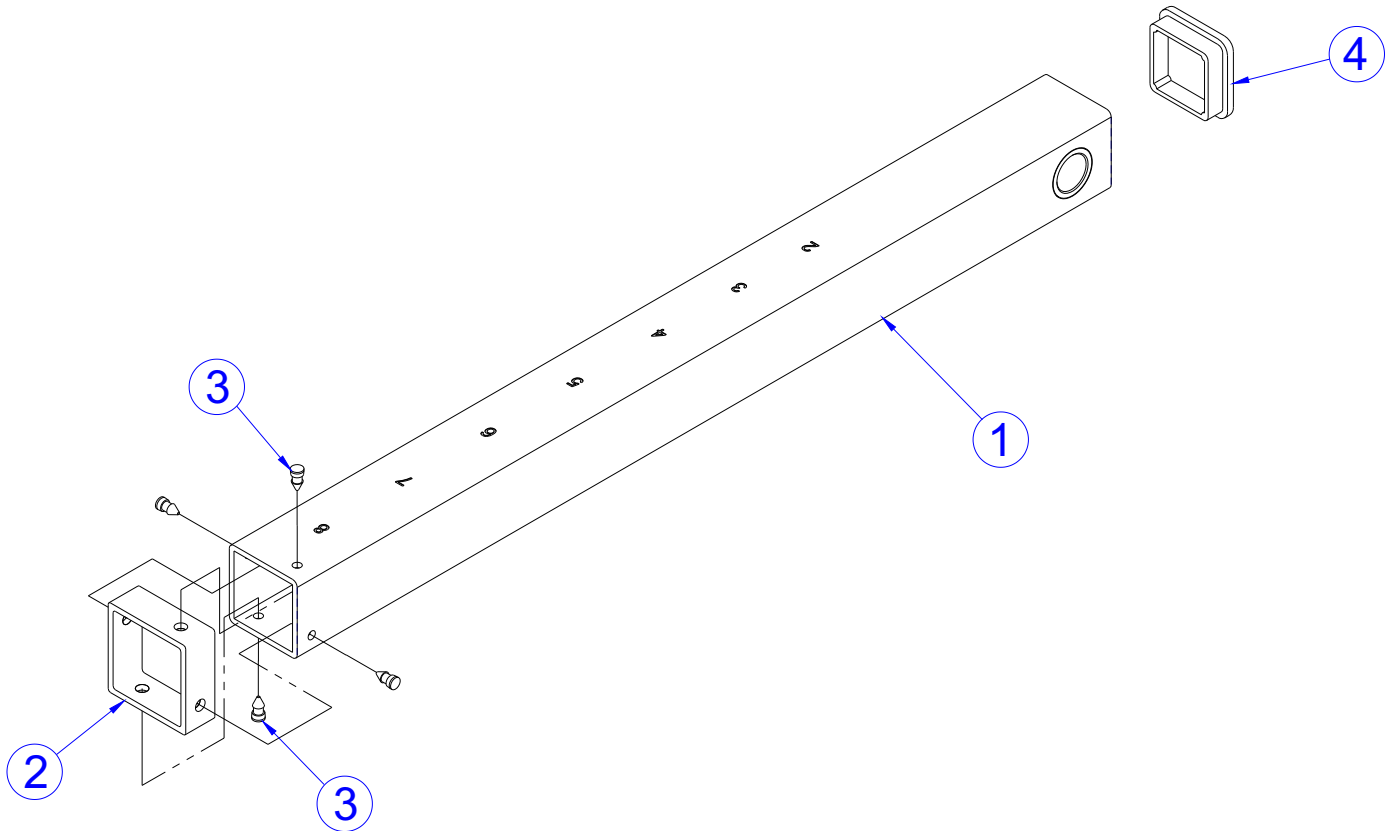

ITEM NO.	QTY.	PART NO.	DESCRIPTION
1	1	7962201	WLDMT, FWMAB ADJ. SLIDE
2	1	7662301	BUSHING, FWMAB SLIDE
3	4	7662301	PIN-GUIDE, FWMAB
4	1	7477501	CAP, END, 1-3/4 SQ, 11GA SGRY

FWMAB FREE WEIGHT MULTI-ANGLE BENCH SEAT ASSEMBLY - 7660501

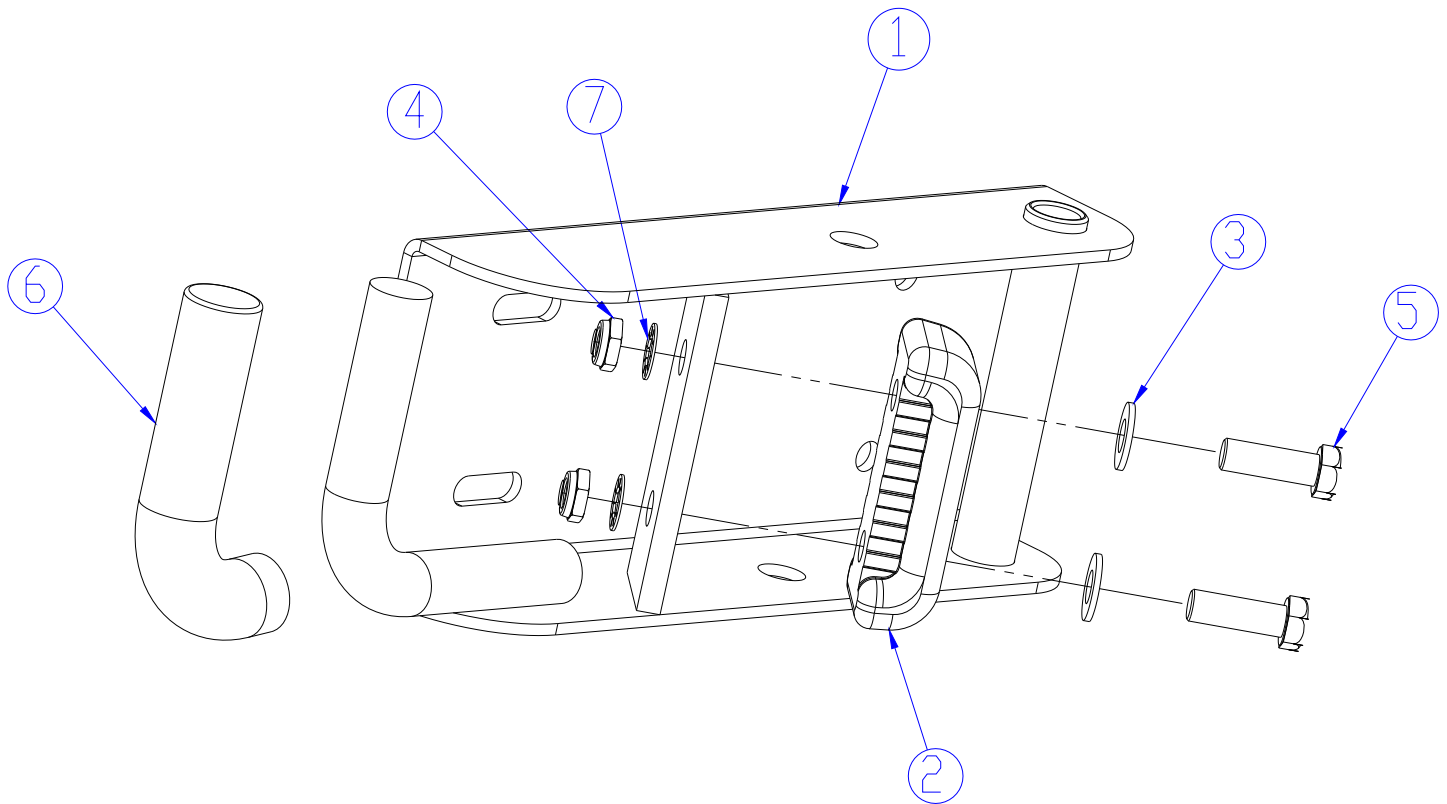

ITEM NO.	QTY.	PART NO.	DESCRIPTION
1	1	7660601	WLDMT, FWMAB SEAT ASSY
2	1	7352001	BUMPER, 2-1/8 X 4-5/8
3	2	3102507	WASHER, TYPE A PLAIN
4	2	3102804	NUT, NYLOCK-JAM 1/2-13 ST ZN
5	2	3239306	1/2-13 X 1.50 UNS HEX FHB G5 ZN
6	1	H-GRIP	HandGrip
7	2	3239505	WSH, .500 IN-D ST ZN

FWMAB FREE WEIGHT MULTI-ANGLE BENCH SEAT BACK ASSEMBLY - 7661401

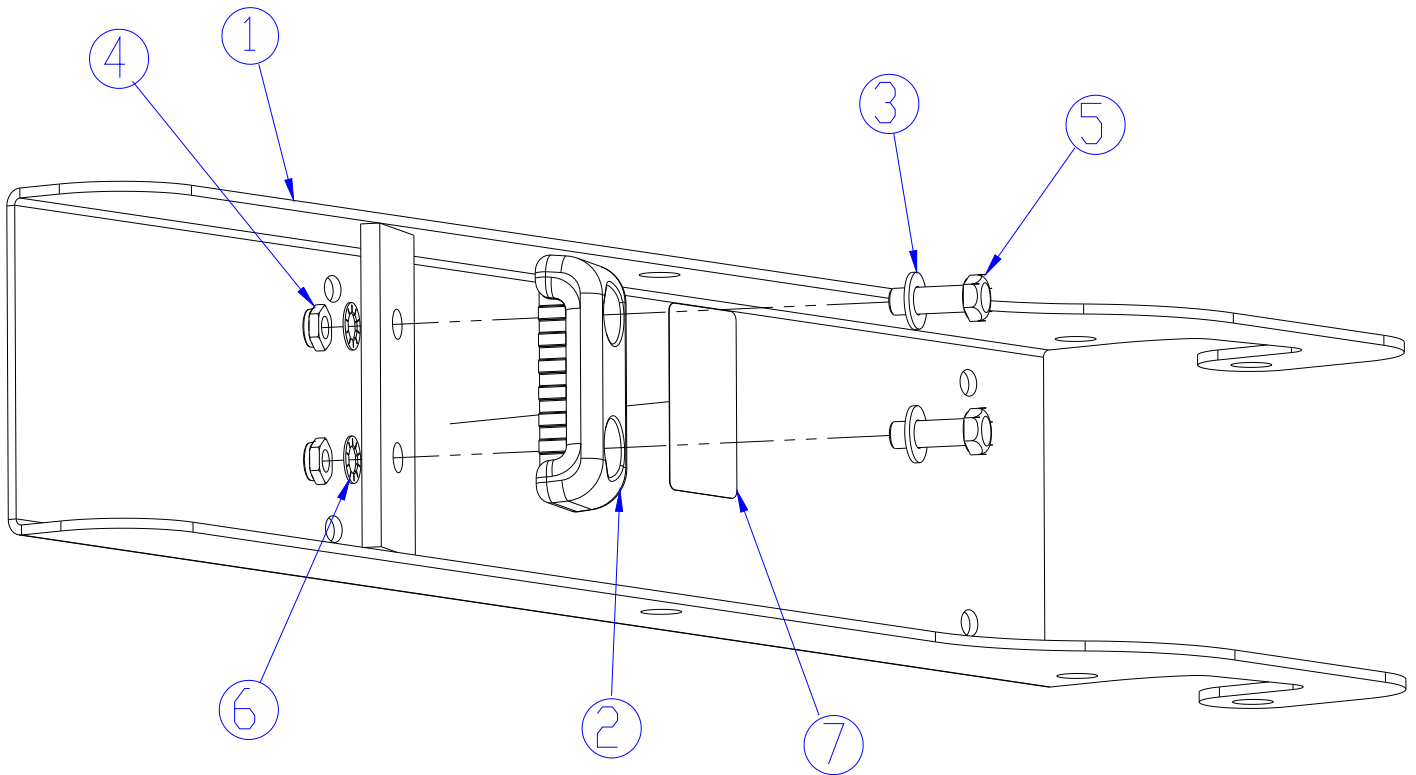

ITEM NO.	QTY.	PART NO.	DESCRIPTION
1	1	7661501	WLDMT, FWMAB BENCH BACK
2	1	7352001	BUMPER, 2-1/8 X 4-5/8
3	2	3102507	WASHER, TYPE A PLAIN
4	2	3102804	NUT, NYLOCK-JAM 1/2-13 ST ZN
5	2	3239306	1/2-13 X 1.50 UNS HEX FHB G5 ZN
6	2	3239505	WSH, .500 IN-D ST ZN
7	1	7571301	LABEL, SERIAL NUMBER