



Disassembly of Waste Electrical and Electronic Equipment (WEEE) Manual

EU Waste Electronic and Electrical Equipment Directive require producers to provide information of the different electronic and electrical materials and components found in their products at its end-of-life, and disassembly references to treatment and recycling facilities.

The disassembly information for this product has been prepared for use by a recognized treatment or recycling facility and is not intended to be used by others.

1. Product information
2. Materials and components list for selective treatment
3. Disassembly tools
4. Disassembly references

The following information is intended only for the use of treatment and recycling facilities.

All disassembly instructions should be performed with the power switch in the OFF position. Disconnect the power cord from the wall outlet and from the printer before continuing. If there are any other devices attached to the printer, then turn them off as well, and unplug any cables going into the printer.

1. Product information

Model name(s)—Indicate all model name(s) within the product family.

Model name
MX710 series – Lexmark MX710de (Lexmark XM5163), Lexmark MX710de3, Lexmark MX710dhe, Lexmark MX711de (Lexmark XM5170), Lexmark MX711de3, Lexmark MX711dhe, Lexmark MX711dthe
MX810 series – Lexmark MX810de (Lexmark XM7155), Lexmark MX810dte (Lexmark XM7155x), Lexmark MX810dfe, Lexmark MX810dme, Lexmark MX810dxe, Lexmark MX810dpe, Lexmark MX810dtme, Lexmark MX810dtfe, Lexmark MX810dxme, Lexmark MX810dxfe, Lexmark MX810dxpe, Lexmark MX810dtpe Lexmark MX811de (Lexmark XM7163), Lexmark MX811dte (Lexmark XM7163x), Lexmark MX811dfe, Lexmark MX811dme, Lexmark MX811dxe, Lexmark MX811dpe, Lexmark MX811dtme, Lexmark MX811dtfe, Lexmark MX811dxme, Lexmark MX811dxfe, Lexmark MX811dxpe, Lexmark MX811dtpe Lexmark MX812de (Lexmark XM7170), Lexmark MX812dpe, Lexmark MX812dte (Lexmark XM7170x), Lexmark MX812dfe, Lexmark MX812dme, Lexmark MX812dxe, Lexmark MX812dtme, Lexmark MX812dtfe, Lexmark MX812dxme, Lexmark MX812dxfe, Lexmark MX812dxpe, Lexmark MX812dtpe

* Add rows as needed

2. Materials and components list for selective treatment

Items	Quantity	Notes
Polychlorinated biphenyls (PCB) containing capacitors	0	N/A

Mercury containing components, such as switches or backlighting lamps	0	N/A
Batteries	1	Lithium Manganese Dioxide coin cell located on the system controller card
Printed circuit boards greater than 10 cm ²	11	– For MX710de, Lexmark MX710de3, and MX711dthe (locations illustrated in 4.2) 10 for MX710de and MX711dhe 9 for MX711de, Lexmark MX711de3
	25	– For MX812dtpe (locations illustrated in 4.2) 24 for MX810/811/812 dpe, dxpe 23 for MX810/811/812dtme, MX810/811/812dxme 22 for MX810/811/812dte, dme, dtfe, dxfe 21 for MX810/811/812de, dfe, dx
Toner cartridges, liquid and pasty, as well as colour toner	1	Located inside front cover
Plastic containing brominated flame retardants	4 Fans; 46 Sensors; 8 Fuser parts	Fan(s) and Sensors (locations illustrated in 4.2) Plastic parts located in the fuser assembly marked with recycle code that includes "FR17" or "FR16"
Asbestos waste and components which contain asbestos	0	N/A
Cathode ray tubes	0	N/A
Chlorofluorocarbons (CFC), Hydrochlorofluorocarbons (HCFC) or Hydrofluorocarbons (HFC), Hydrocarbons (HC)	0	N/A
Gas discharge lamps	0	N/A
Liquid Crystal Display (LCD) greater than 100 cm ² and those back-lighted with Gas discharge lamps	1	LCD located inside OP panel
External electrical cables	1	Power cord located on the back lower left quadrant
Components containing refractory fibres	0	N/A
Components containing radioactive substances	0	N/A
Electrolyte capacitors containing substances of concern ¹	10	Capacitor(s) located on Power Supply (locations illustrated in 4.2)
¹ With (height > 25 mm, diameter > 25 mm or proportionately similar volume)		

3. Disassembly tools

Item
#2 Phillips screwdriver, magnetic
Wire cutter
E-clip puller or small flat-head screwdriver
Standard slotted head screwdriver

4. Disassembly references

4.1. Removal procedure(s)



MX710, MX810 series WEEE removal

WEEE materials and components removal procedures are available upon request.

Contact: recycling@lexmark.com

4.2. Graphical illustration of material's and component's location

See next page

MX710, MX810 Series Location

Fusers

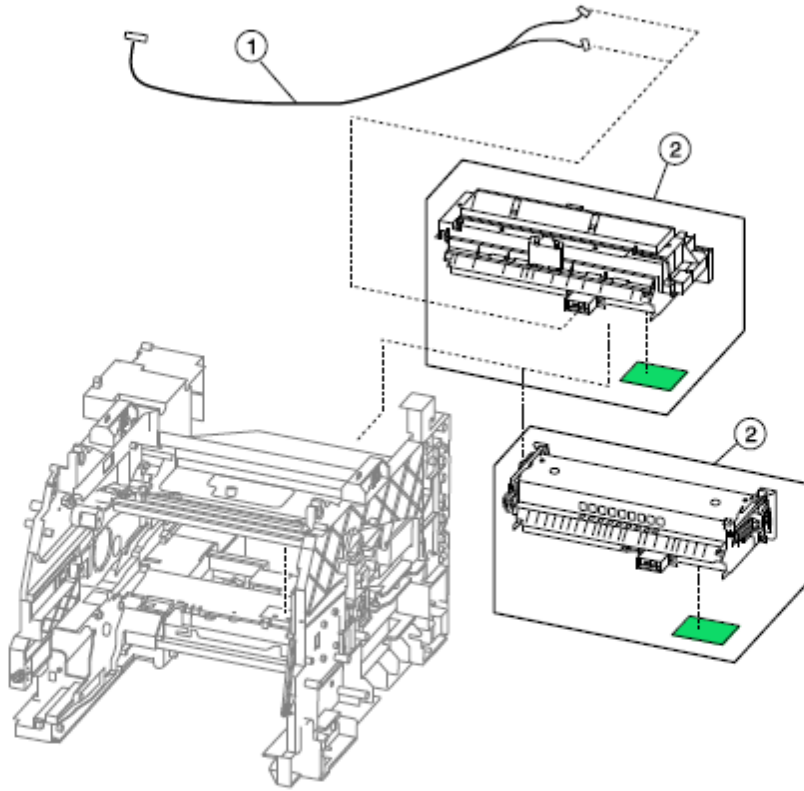

Index	Description
1	Fuser data cable)
2	Fusers

MX710, MX810 Series Location

Electronics

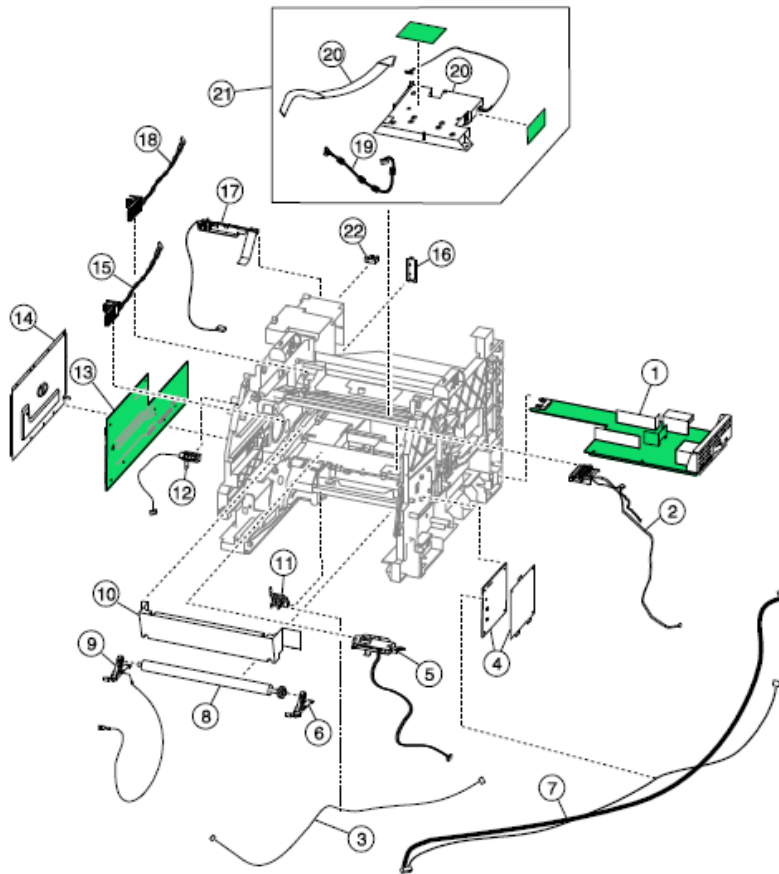

Index	Description
1	LVPS (universal)
2	Toner leve / imaging unit high voltage contact
3	Input sensor cable
4	HVPS
5	Sensor (toner density)Includes shutter and cable
6	Transfer roller right arm
7	HVPS/toner cartridge fan cable
8	Transfer roller
9	Transfer roller left arm with cable
10	Printhead access cover
11	Sensor (input)
12	Sensor (control panel interlock)Includes bracket and cable
13	Controller board (2.4" display printers only)
13	Controller board (4.3" tilting display printers only)

Index	Description
13	Controller board (7" tilting display printers only)
14	Controller board access shield
15	Toner cartridge smart chip contact with cable
16	Option card cover plate
17	Sensor (standard bin full) with output bin guide
18	Imaging unit smart chip contact with cable
19	Printhead power cable
20	Printhead video cable
21	Laser printhead (quad diode) (belt fuser printers only)Includes data and power cables
21	Laser printhead (dual diode) (hot roller fuser printers only)Includes data and power cables
22	Interrupt sensor

MX710, MX810 Series Location

Drive Motors

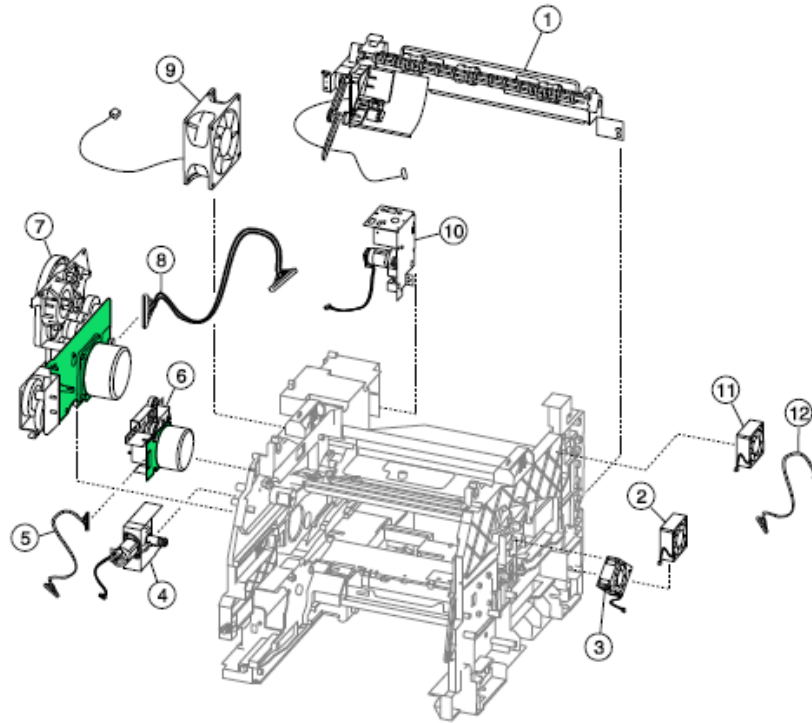

Index	Description
1	Duplex motor with cable
2	Duplex cooling fan
3	Cartridge cooling fan
4	Toner add motor with cable
5	Fuser drive motor cable
6	Fuser drive motor (belt fuser printers only)
6	Fuser drive motor (hot roll fuser printers only)
7	Main drive motor
8	Main motor cable
9	Main cooling fan with cable
10	Upper redrive motor with cable
11	Fuser cooling fan (hot roll fuser printers only)
12	Fuser cooling fan cable (hot roll fuser printers only)

**MX710, MX810 Series
Location**

Control Panel

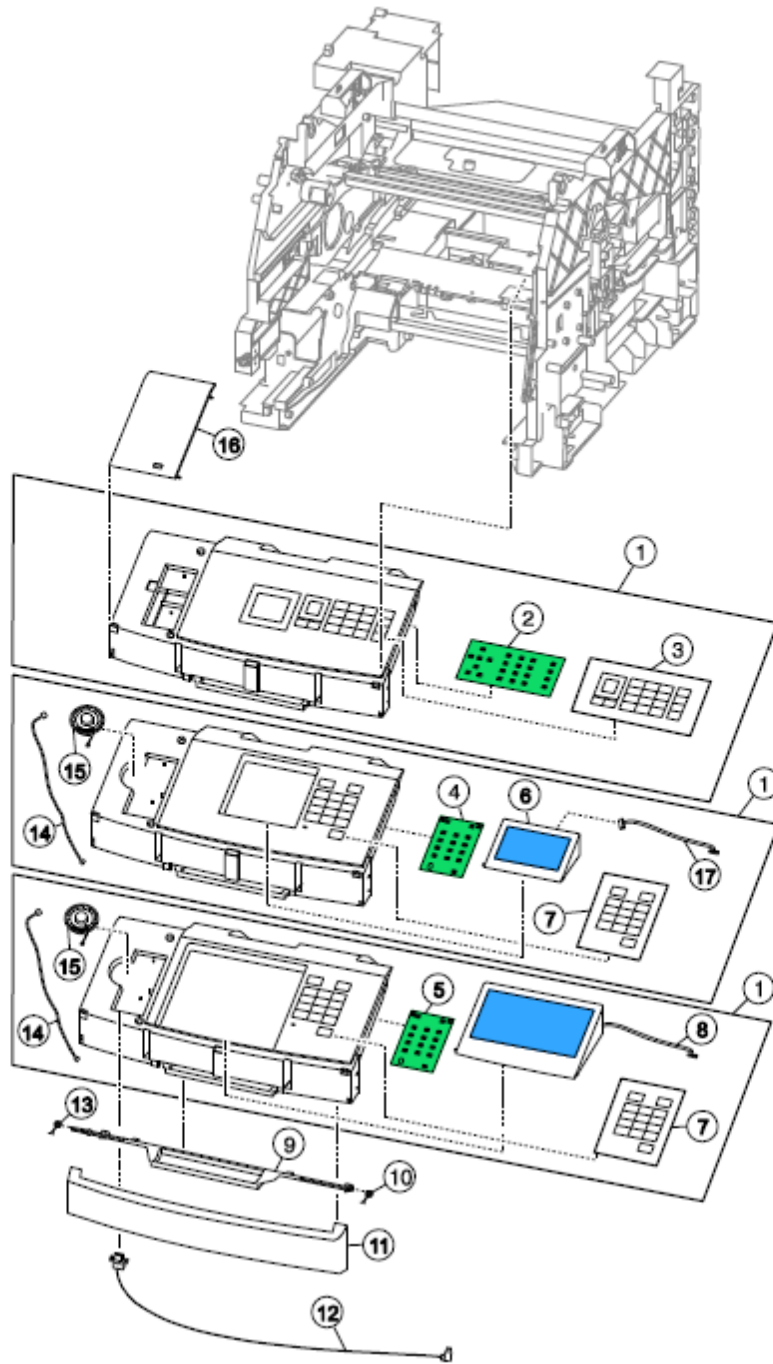

**MX710, MX810 Series
Location**

Index	Description
1	2.4" LCD control panel
1	4.3" touch screen control panel
1	7" touch screen control panel
2	Control panel board (2.4" display only)
3	Control panel buttons (2.4" display only)
4	Control panel board (4.3" tilting display only)
5	Control panel board (7" tilting display only)
6	4.3" tilting display
7	Control panel buttons (4.3" and 7" tilting displays only)
8	7" tilting display
9	Control panel latch
10	Torsion spring
11	Control panel front cover
12	USB cable
13	Torsion spring
14	Speaker cable
15	Control panel speaker
16	Control panel left bezel
17	Display to control panel board cable (4.3" tilting display only)

MX710, MX810 Series Location

250-sheet Tray Option

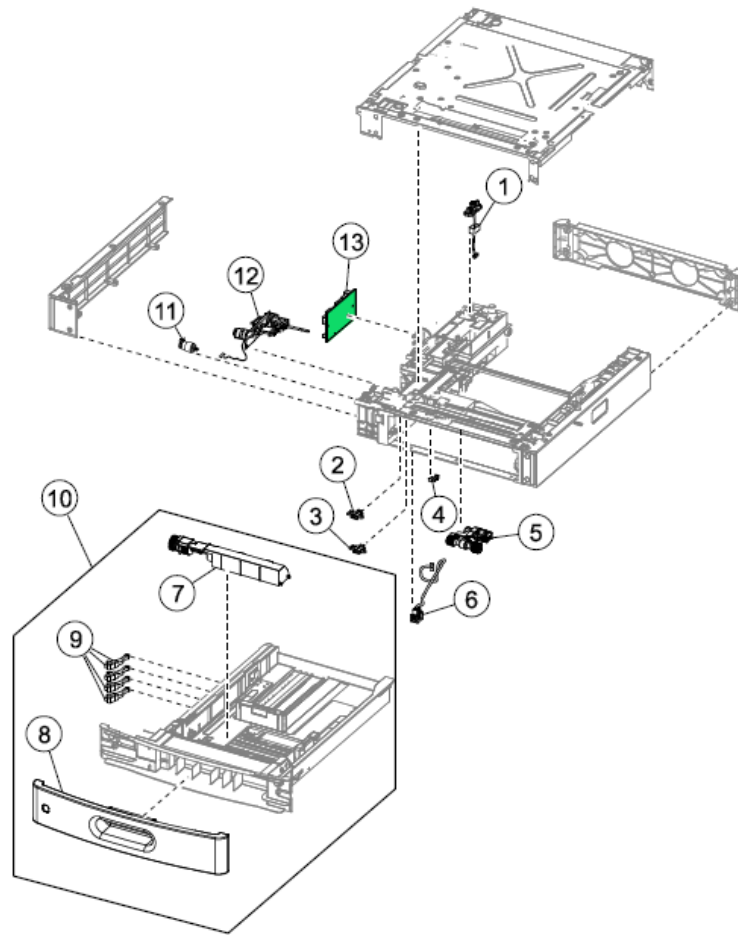

Index	Description
1	250-sheet tray option upper interface cable
2	Sensor (pass through)
3	Sensor (pick)
4	Sensor (pick roller position)
5	Pick roller
6	250-sheet tray option lower interface cable
7	Separation roller
8	250-sheet tray front cover
9	Media size actuator
10	250-sheet tray
11	250-sheet tray option transport motor
12	Media feeder
13	250-sheet tray option controller PCBA

MX710, MX810 Series Location

550-sheet Tray Option

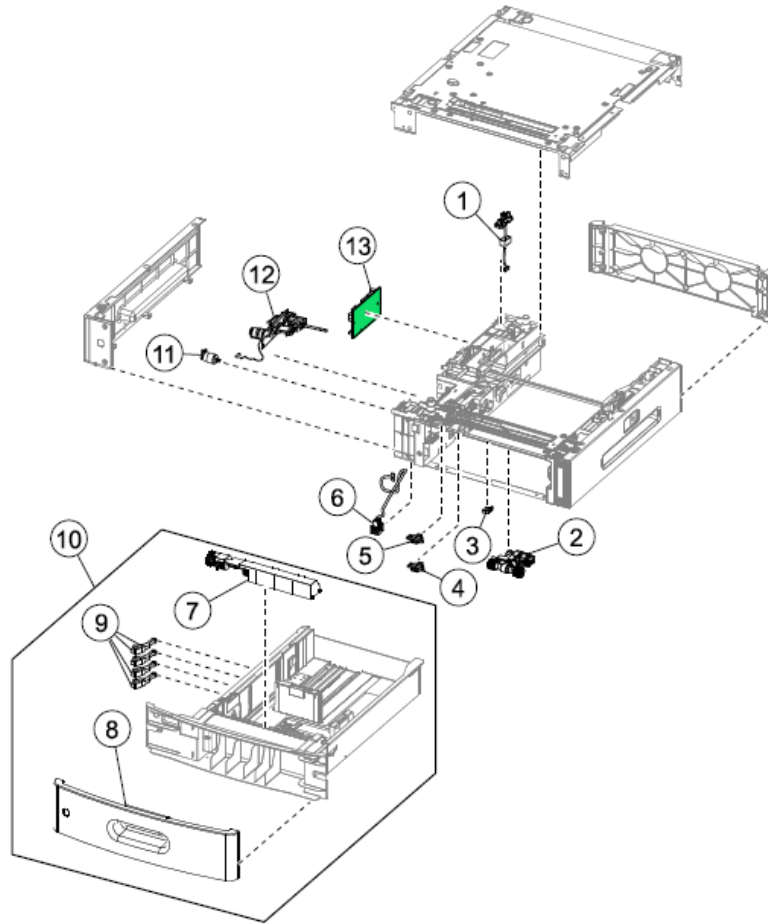

Index	Description
1	550-sheet tray option upper interface cable
2	Pick roller
3	Sensor (pick roller position)
4	Sensor (pick)
5	Sensor (pass through)
6	550-sheet tray option lower interface cable
7	Separation roller
8	550-sheet tray front cover
9	Media size actuator
10	550-sheet tray
11	550-sheet tray option transport motor
12	Media feeder
13	550-sheet tray option controller PCBA

MX710, MX810 Series Location

High Capacity Input Tray Option

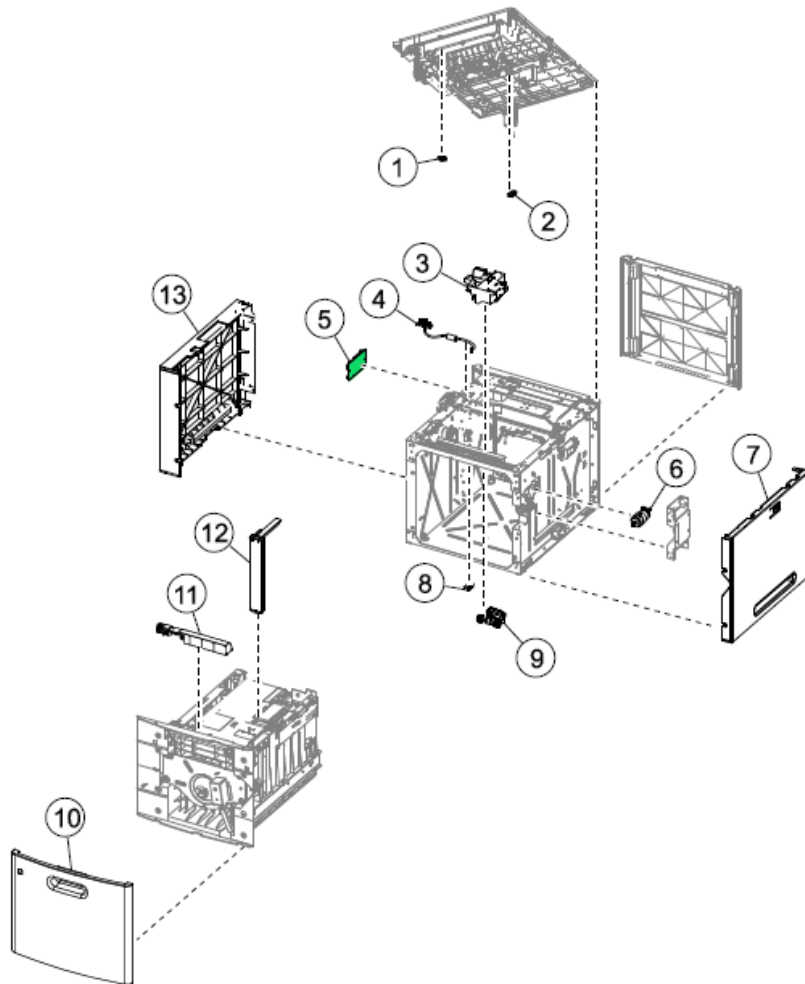

Index	Description
1	Sensor (HCIT pick) with cable
2	Sensor (HCIT media low) with flag
3	HCIT option media feeder
4	HCIT option interface cable
5	HCIT option controller PCBA
6	HCIT option lift drive motor
7	HCIT option right cover
8	Sensor (HCIT pick roller position)
9	Pick roller
10	HCIT front cover
11	Separation roller
12	HCIT media guide
13	HCIT option left cover

**MX710, MX810 Series
Location**

Output Expander Option

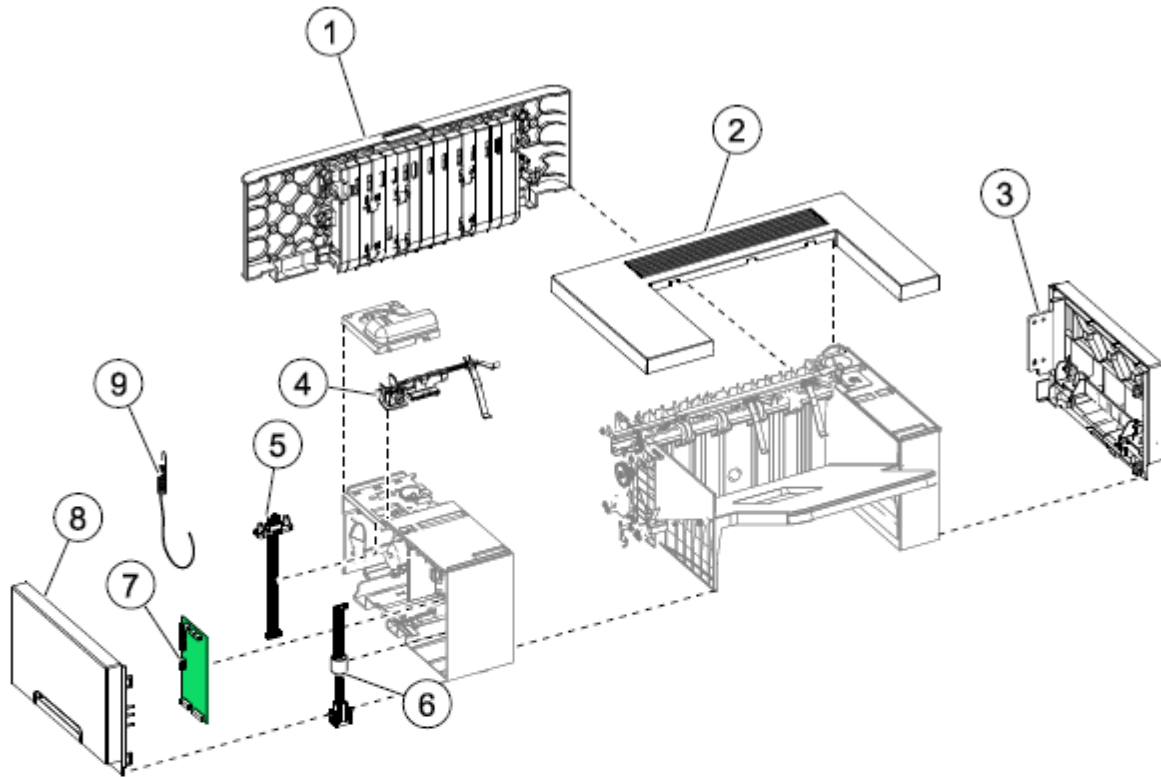

Index	Description
1	Output expander rear door
2	Output expander top cover
3	Output expander right cover
4	Sensor (media bin full) with flag
5	Upper interface cable
6	Lower interface cable
7	Output expander controller PCBA
8	Output expander left cover
9	Spring with string
NS	Actuator flag (media bin full)

**MX710, MX810 Series
Location**

High Capacity Output Expander Option

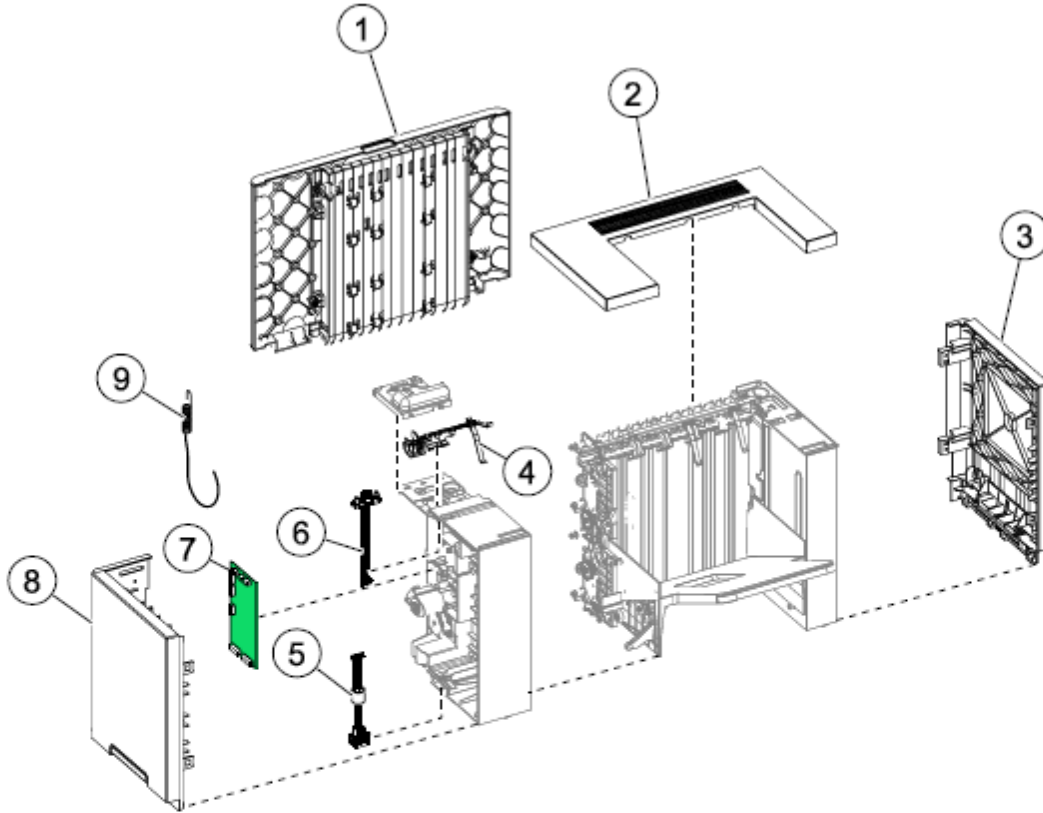

Index	Description
1	HCOE rear door
2	HCOE top cover
3	HCOE right cover
4	Sensor (HCOE media bin full) with flag
5	HCOE lower interface cable
6	HCOE upper interface cable
7	HCOE controller PCBA
8	HCOE left cover
NS	Actuator flag (media bin full)

**MX710, MX810 Series
Location**

Stapler Finisher Option

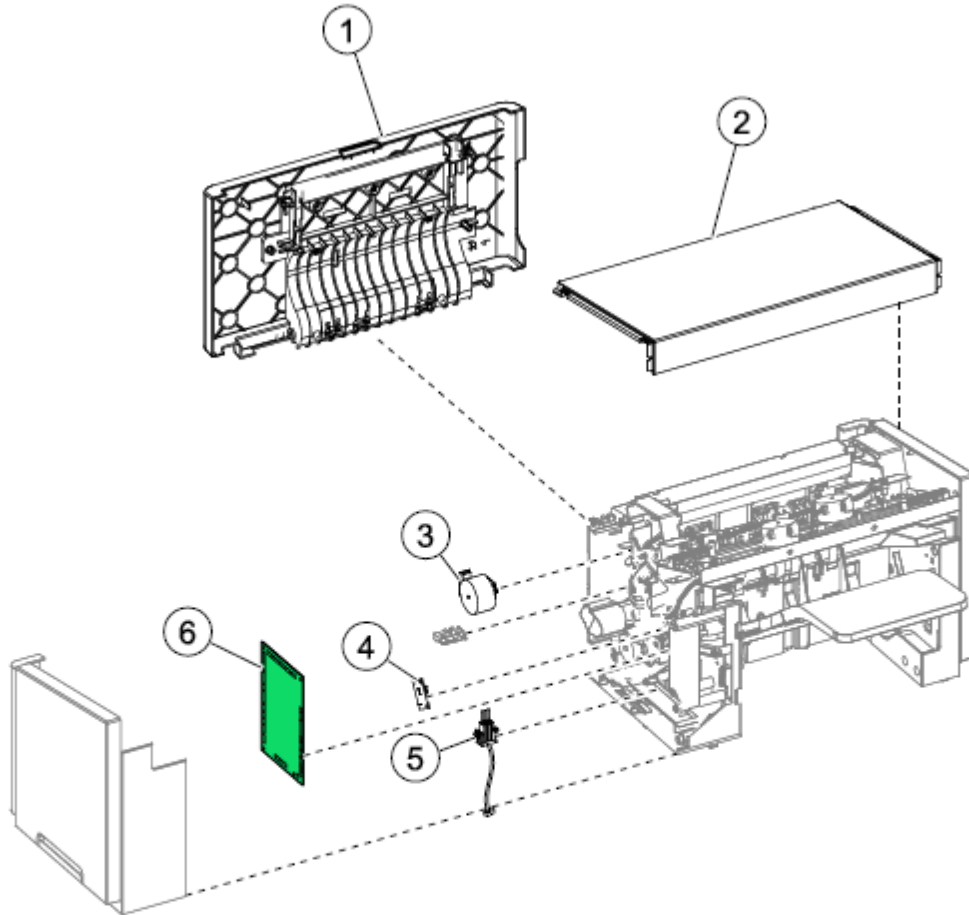

Index	Description
1	Stapler rear door
2	Stapler top cover
3	Stapler paddle drive motor
4	Sensor (bin full receive)
5	Stapler lower interface cable
6	Stapler controller PCBA

MX710, MX810 Series Location

Mailbox Option 1

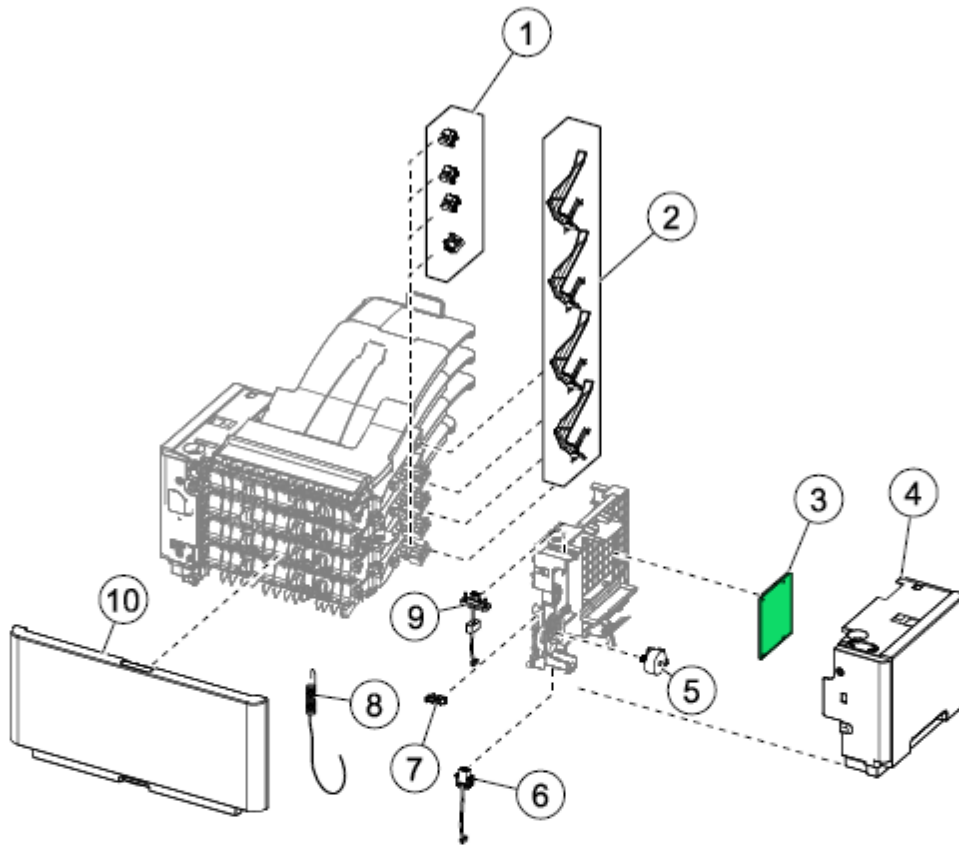

Index	Description
1	Sensor (bin full receive)
2	Mailbox media bin full flag
3	Mailbox controller PCBA
4	Mailbox left cover
5	Mailbox divert motor
6	Mailbox lower interface cable
7	Mailbox sensor (divert motor)
8	Mailbox spring with string
9	Mailbox upper interface cable
10	Mailbox rear door

MX710, MX810 Series Location

Mailbox Option 2

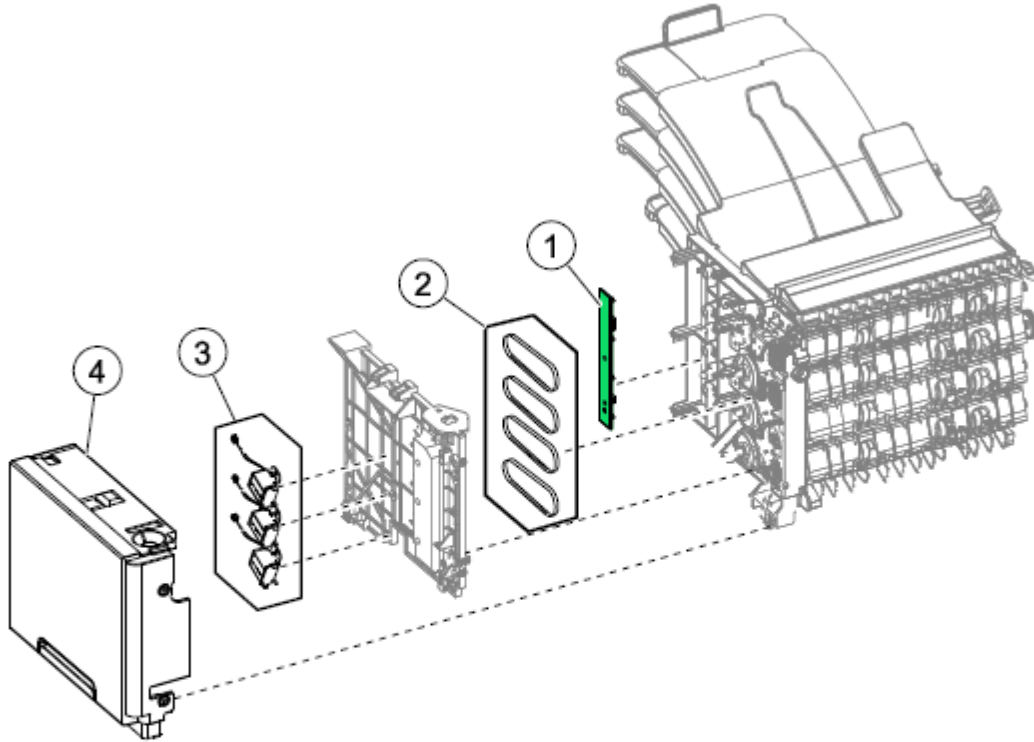

Index	Description
1	Mailbox output bin LED assembly
2	Mailbox belt
3	Mailbox solenoid
4	Mailbox right cover

MX710, MX810 Series Location

Sensors

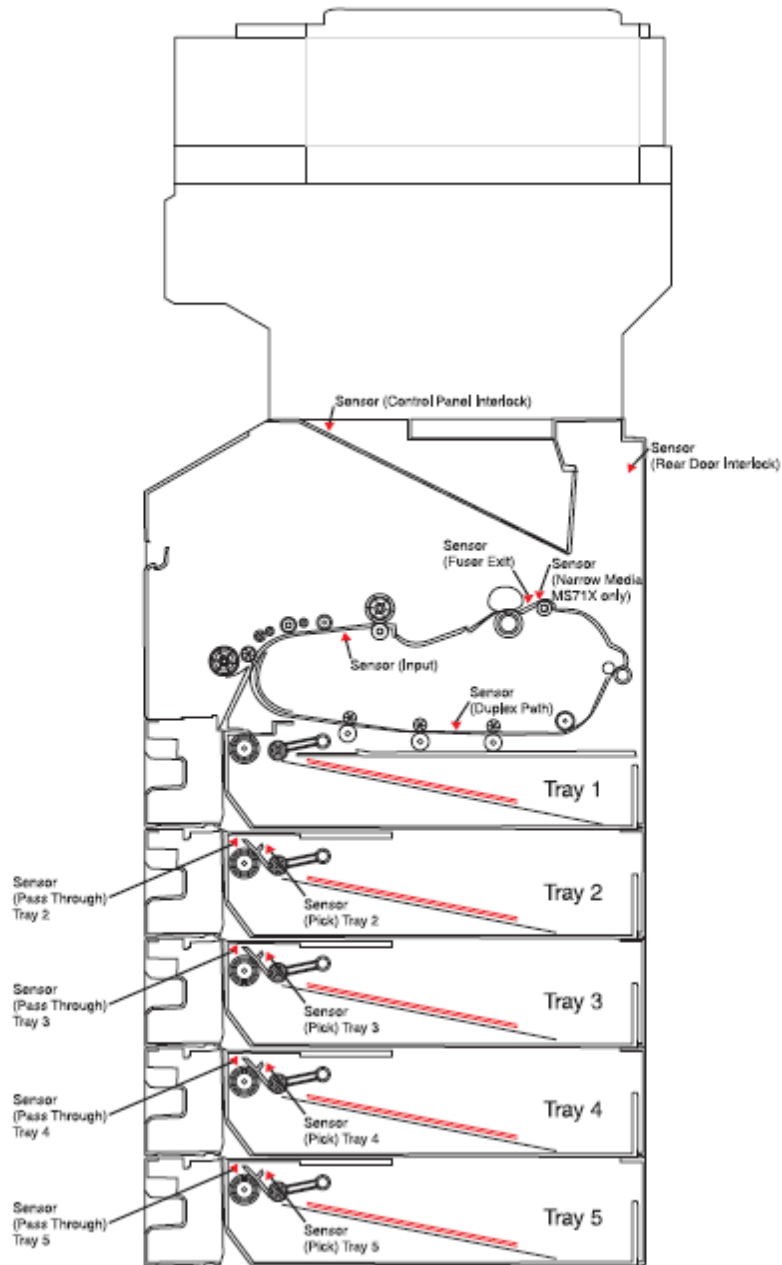

Picture does not show all sensors used by the product

Appendix A
Plastic containing brominated flame retardants

Part Description	Parts Marking	Location
Guide - Lower Exit	PET-(GF+MD)40FR(17)	FUSER AREA
Guide - Upper Exit	PET-(GF+MD)40FR(17)	FUSER AREA
Guide - Fuser Lower Entry	PET-(GF+MD)40FR(17)	FUSER AREA
Plate - Transfer	PC-CD10 FR(16)	FUSER AREA
Base - Fuser Wiper HR	PET-(GF+MD)40 FR(17)	FUSER AREA
Wiper - Fuser Non Wick HR	PSSY-GF22 FR(17)	FUSER AREA
Guide (Mechanical) - Lower Exit	PA66-GF30 FR(17)	FUSER AREA
Guide (Mechanical) - Entry	PET-(GF+MD)40 FR(17)	FUSER AREA