

38" REVITALIZER

38" REVITALIZER MFG. NO. 1690079

OPERATOR'S MANUAL

TABLE OF CONTENTS

	Page
SAFETY PRECAUTIONS	Inside Cover
INSTALLATION	1
OPERATION	2
ADJUSTMENTS	3
MAINTENANCE	4

SPECIFICATIONS SUBJECT TO CHANGE WITHOUT NOTICE

PROTECT YOURSELF AND OTHERS

1. Read and be familiar with the owners manual for your tractor and the owners manual for the revitalizer before operating the revitalizer.
2. Do not allow anyone to use the revitalizer unless they have been instructed in how to operate it safely.
3. Never attempt to adjust, repair or service the revitalizer while the tractor engine is running.
4. Do not allow others near the revitalizer when it is operating.
5. Stay clear of the drive belt, revitalizer knives and other moving parts when the tractor engine is running.

REQUIRED ACCESSORIES

Rear Lift Kit

RECOMMENDED ACCESSORIES

Power Lift Kit

NOTE

If Revitalizer is to be used on a tractor which does not have a clutching type power-take-off, it will be necessary to order a drive clutch kit.

INSTALLATION

CAUTION

Do not attempt to install or work on the revitalizer when the tractor engine is running.

1. Position the revitalizer behind the tractor.
2. See Figure 1. Slide the idler arm assembly onto the left end of the rear lift shaft. Attach the lower end of the idler arm assembly to the hitch member with a pin and spring clip.

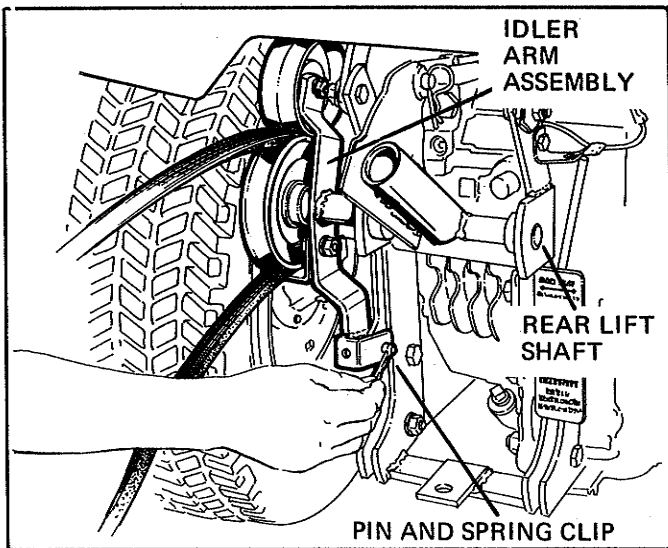

Figure 1.

3. See Figure 2. Lower the tractor lift unit and place the revitalizer lift bar assembly into the tube of the tractor rear lift assembly. Placing a thin film of oil on the lift bar will make it slide in place more easily. Fasten the lift bar in place with the pin and spring clip provided.

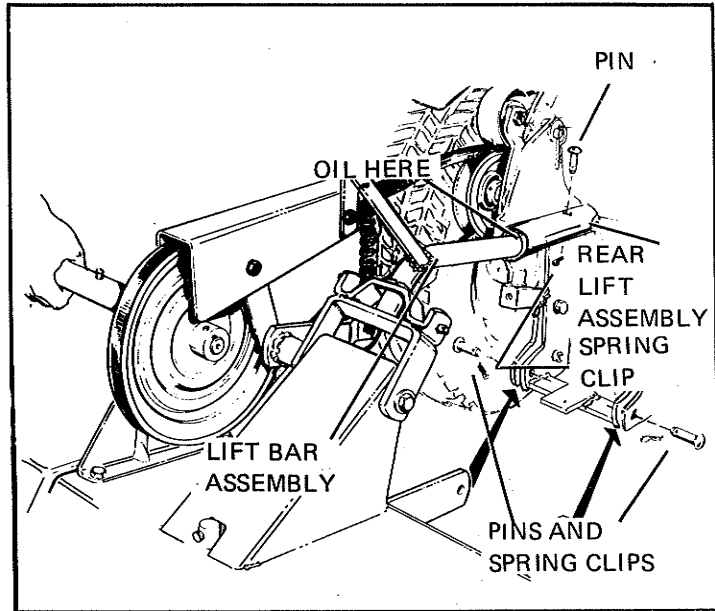

Figure 2.

4. See Figure 3. Move the tractor lift to the raised position. Connect the revitalizer frame assembly to the tractor with 2 pins and spring clips.

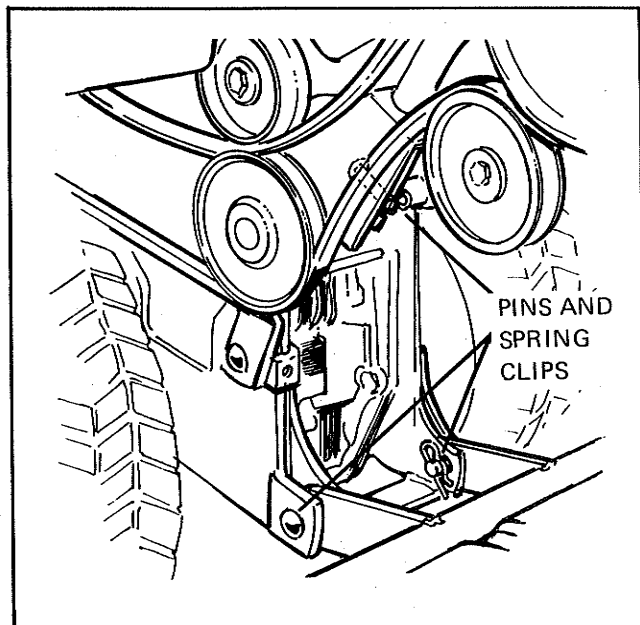

Figure 3.

CAUTION

Insure that the tractor power-take-off is disengaged when doing any work on or around the revitalizer. (See Tractor Manual).

5. See Figure 4. Install the revitalizer drive belt over the power-take-off pulley of the tractor. The belt should be used in the outside groove of the pulley.

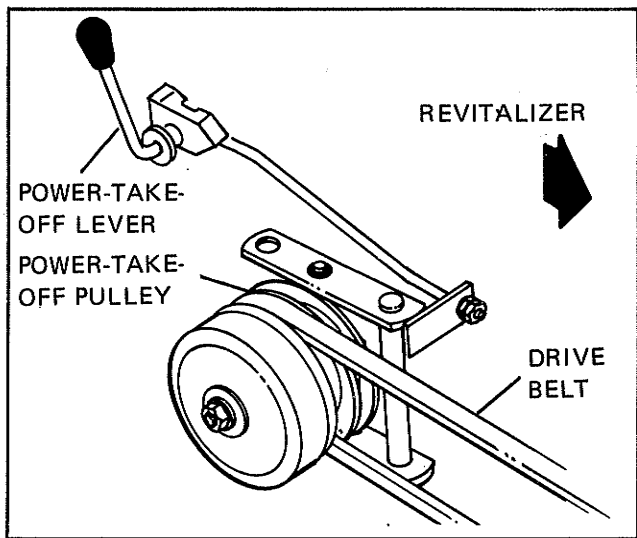

Figure 4.

6. See Figure 5. If the mower is to be used with the revitalizer, remove the lift chain or cable from the tractor lift arm when operating. This is especially beneficial in reducing lifting effort on tractors not equipped with power lift since the revitalizer should be raised when turning to prevent excess lawn damage. It is not advisable to raise the mower when turning if the mower is engaged since operating the mower in the raised position will reduce the life of the mower drive belt.

7. Prior to first use or if the revitalizer has not been used recently, all adjustments listed in the Adjustments section of this manual except the drive chain adjustment should be checked before operating the revitalizer.

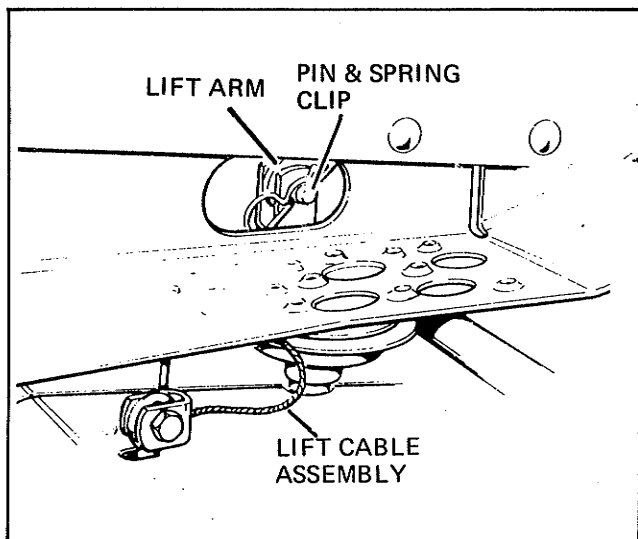

Figure 5.

OPERATION

The Lawn Revitalizer is most effective if used in the Spring and Fall of the year. In the Spring its use will lift out thatch that harbors fungus and create a miniature irrigation system so that the water, fertilizer and air can reach the grass roots. Use the Revitalizer once in the Spring between the time the grass has started to grow vigorously and the time when summer weather might be expected to slow grass growth.

Used in the fall, the revitalizer will raise the summer's accumulation of thatch and create a series of grooves which permit frost to expand the soil for greater porosity. The grass roots will have a better chance to expand during the next growing season.

For best results the grass should be mowed to a length of about 2 inches before the revitalizer is used. This will prevent long grass from interfering with the revitalizing process.

DEPTH ADJUSTMENT

CAUTION

Always insure the tractor engine is stopped before attempting to adjust or work around the revitalizer.

See Figure 6. Adjust the depth with the Revitalizer in the lowered position. The cutting depth of the revitalizer knives may be precisely adjusted by turning the T handle at the rear of the revitalizer clockwise to raise the knives and counter-clockwise to lower them. For use in Spring and Fall as recommended, the knives should be set about 1/2 inch deep. The 1/2 inch depth may be set quite easily and accurately on a level surface by placing a 1/2 inch block under each of the revitalizer guide wheels. **BE SURE THE TRACTOR ENGINE IS STOPPED.** With the power-take-off disengaged or turning, alternately rotate the drive pulley on the revitalizer and turn the depth adjusting handle until the ends of the knives just hit the ground surface. The revitalizer should now be set at 1/2 inch cutting depth. The grooves in the ground may also be checked after operating a short distance to insure the correct depth setting.

PREPARATION FOR OPERATING

With the revitalizer (and mower if attached) disengaged and in the raised position, move to the area to be revitalized. The mower may be used with the revitalizer if the grass is not long or wet as to require full engine power for mowing. When using the revitalizer it should be raised when turning to prevent excessive uprooting of grass, but it is neither advised nor necessary to raise the mower. This may best be accomplished by disconnecting the mower lift cable from the lift lever by removing the spring clip and pin. See step 7 of installation instructions.

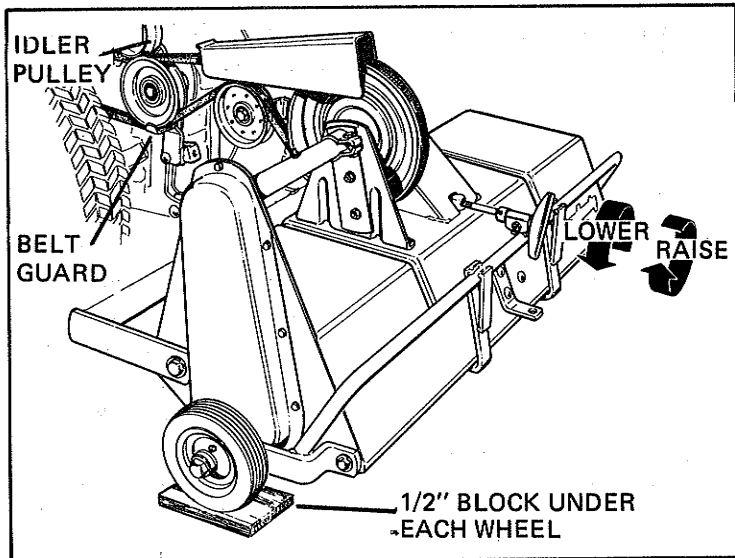

Figure 6.

ENGAGING THE REVITALIZER

The revitalizer drive is engaged by engaging the power-take-off of the tractor. (See Tractor Manual for correct procedure).

TRAVEL SPEED AND DIRECTION

The revitalizer should be used with the tractor engine at 3/4 to full speed. Operating conditions will determine the best ground speed. Under normal conditions where the ground is smooth and soft a speed of 2 to 4 miles per hour should be satisfactory.

If the ground is hard, rocky or rough a slower speed may be advisable since the revitalizer will not be as effective under these conditions.

Travel the long direction of the lawn to minimize turns. Before turning, raise the revitalizer to prevent excessive uprooting of grass. On the second and successive passes, be sure to drive so the revitalizer slightly overlaps that portion of the lawn already revitalized.

NOTE: Do not make sharp turns with unit in ground, since this will cause lawn damage.

If wire or other foreign material get caught in the revitalizer, stop the tractor and disengage the power-take-off immediately. STOP THE TRACTOR ENGINE BEFORE ATTEMPTING TO WORK AROUND THE REVITALIZER.

PREPARING A SEEDBED

The revitalizer may be used to prepare a seedbed for reseeding a sparse area by making a second pass diagonally to the first one at about a 45° angle. Use a depth setting of approximately 1/2 inch.

REMOVING THE THATCH

Dead grass and thatch should be removed after using the revitalizer. A vacuum collector system is excellent for this purpose. For best results allow the thatch and grass to dry for a few hours before using the vacuum collector. A sweeper will also work well in removing the thatch.

TROUBLESHOOTING

If the thatch is not being lifted effectively:

1. Ground speed may be too fast - use a lower ground speed.
2. Engine speed may be too slow - operate the engine at 3/4 to full throttle.
3. Long grass may be interfering - grass should be cut to about 2" before revitalizing.
4. The revitalizer drive belt may be slipping - check the belt tension to be sure it is correct.

If thatch removed is not uniform or an unusual amount of green grass is being torn up:

1. Check to see if wire, sticks, etc. are caught on the knives.
2. Check the depth of the grooves in the ground. A depth of 1/2 inch is correct under most conditions.

If belt tension is not sufficient:

1. The belt may be of the wrong length or construction, use only the correct belt.

NOTE: Tension on the revitalizer drive belt is regulated by the idler pulley. Be sure that the attachment is connected correctly and operating as described earlier.

ADJUSTMENTS

CAUTION

Do not attempt to do any work with tractor engine running.

DRIVE CHAIN ADJUSTMENT

If inspection reveals that there is slack in the drive chain or it must be replaced, use the following procedure to tighten the chain:

1. See Figure 7. With the chain cover removed so the chain is visible, loosen, but do not remove the two bolts holding each end of the bearing housing.
2. Pull upward on the bearing housing until all slack is removed from the chain. Before tightening the bolts at each end of the bearing housing, insure that the bearing housing is parallel to the revitalizer housing. This may be easily and accurately done by measuring the distance from the bearing housing to the revitalizer housing at each end of the bearing housing. When the two distances are equal, the bearing housing is parallel to the revitalizer housing. (See Figure 7).

After insuring all slack has been removed from the chain and the bearing housing is parallel to the revitalizer housing, tighten the two adjustment bolts at each end of the bearing housing securely.

Put a liberal coating of automotive grease on the chain and replace chain cover.

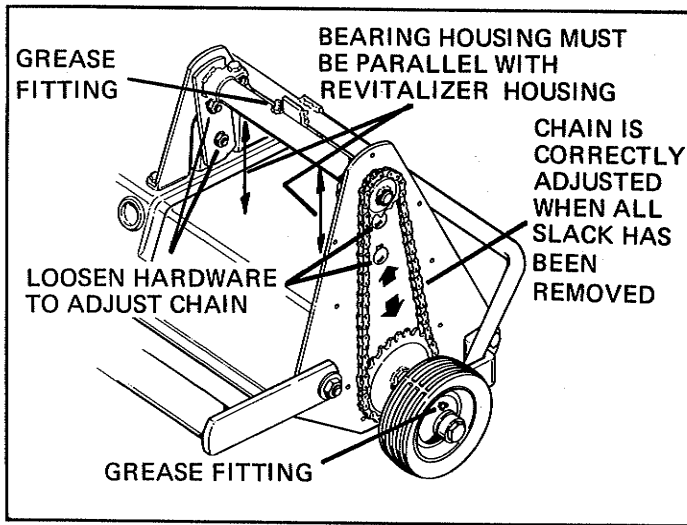

Figure 7.

MAINTENANCE

REPLACEMENT PARTS

Use only genuine replacement parts. Be prepared to give your dealer the Manufacturing number.

CAUTION

Always be sure the tractor engine is stopped before attempting to work around the revitalizer.

AFTER EACH USE

Each time the revitalizer is used the knives should be checked for wire or other material which may be caught in them. Clean any foreign material away from the knives for best operation.

EVERY 10 HOURS

There are five grease zerks located on the revitalizer which should be lubricated with automotive grease after every 10 hours of use. They are located one on each of the two guide wheels, one on each of the two tine shaft bearings and one on the crossdrive housing. (See figure 7 and 8). Lubricate each zerk with 5 shots of grease or until grease is pushed out around the bearings.

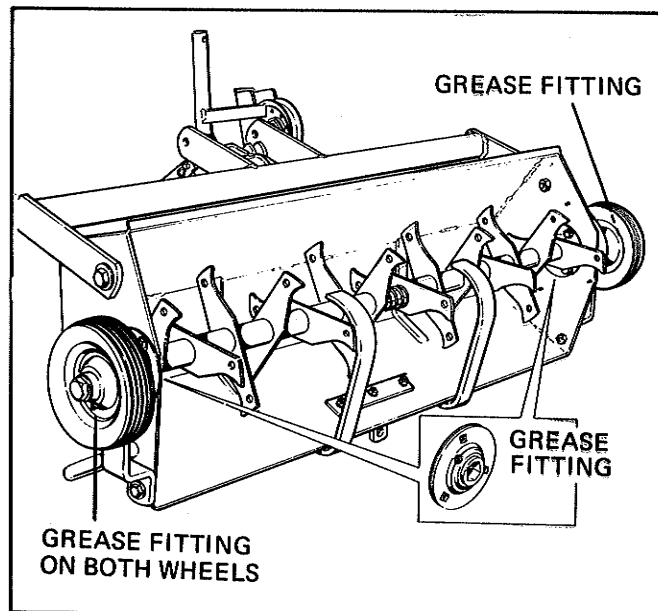

Figure 8.

Lubricate all pivot points with engine oil to help prevent wear. (See Figure 9.) Do not get oil on the drive belt or the pulleys.

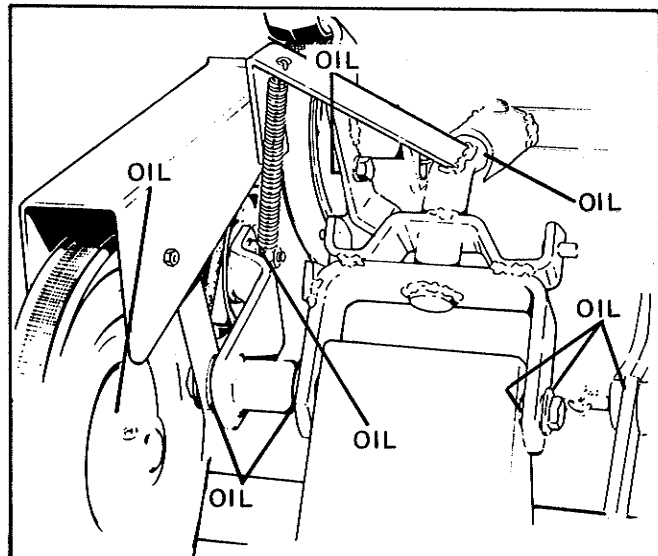

Figure 9.

38" REVITALIZER

MFG. NO. 1690079

PARTS MANUAL

HOUSING, TINE AND DRIVE

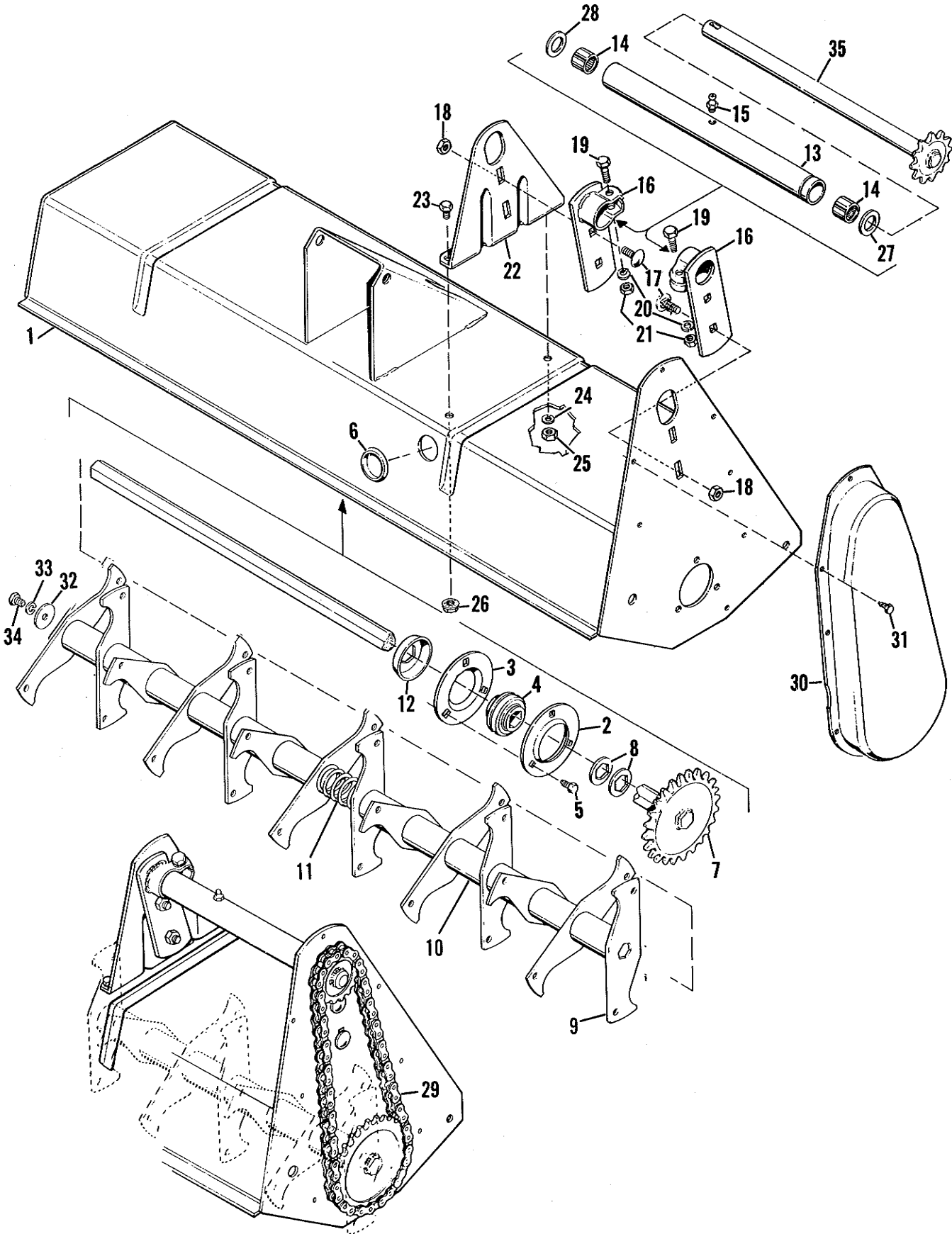

HOUSING, TINE AND DRIVE

Ref. No.	Part No.	Qty.	Description
1	1652589	1	HOUSING ASSEMBLY
2	172972	2	FLANGE, Bearing
3	172973	2	FLANGE, Bearing
4	172347	2	BEARING
5	924856	6	SCREW, Hex Hd., Swageform 5/16"-18 x 1/2" lg.
6	172934	1	BUTTON, Plug
7	172338	1	TINE SHAFT ASSEMBLY
8	172332	4	WASHER, Hex
9	1652587	14	TINE
10	1652588	12	SPACER
11	170417	1	SPRING
12	172874	2	BEARING, Trash Guard
13	1652586	1	HOUSING, Bearing
14	172747	2	BEARING, Needle
15	921133	1	FITTING, Grease
16	1652585	2	CLAMP SUPPORT ASSEMBLY
17	924801	4	BOLT, Carriage 7/16"-14 x 1" lg.
18	918213	4	NUT, Hex, Jam, 7/16"-14
19	919933	2	CAPSCREW, Hex 5/16"-18 x 1-1/2" lg.
20	917356	2	LOCKWASHER, 5/16"
21	917372	2	NUT, Hex, Full, 5/16"-18
22	172252	1	SUPPORT, Bearing
23	919318	2	CAPSCREW, Hex 5/16"-18 x 5/18" lg.
24	917356	1	LOCKWASHER, 5/16"
25	917372	1	NUT, Hex, Full, 5/16"-18
26	927557	1	NUT, Special, 5/16"-18
27	106069	1	WASHER
28	101022	1	WASHER
29	172891	1	CHAIN
30	172983	1	GUARD, Chain
31	929000	8	SCREW, Taptite 1/4"-20 x 3/8"
32	123144	1	WASHER
33	917356	1	LOCKWASHER, 5/16"
34	919317	1	CAPSCREW, Hex 5/16"-18 x 1/2" lg.
35	172340	1	DRIVE SHAFT ASSEMBLY

CLUTCH AND BELT DRIVE

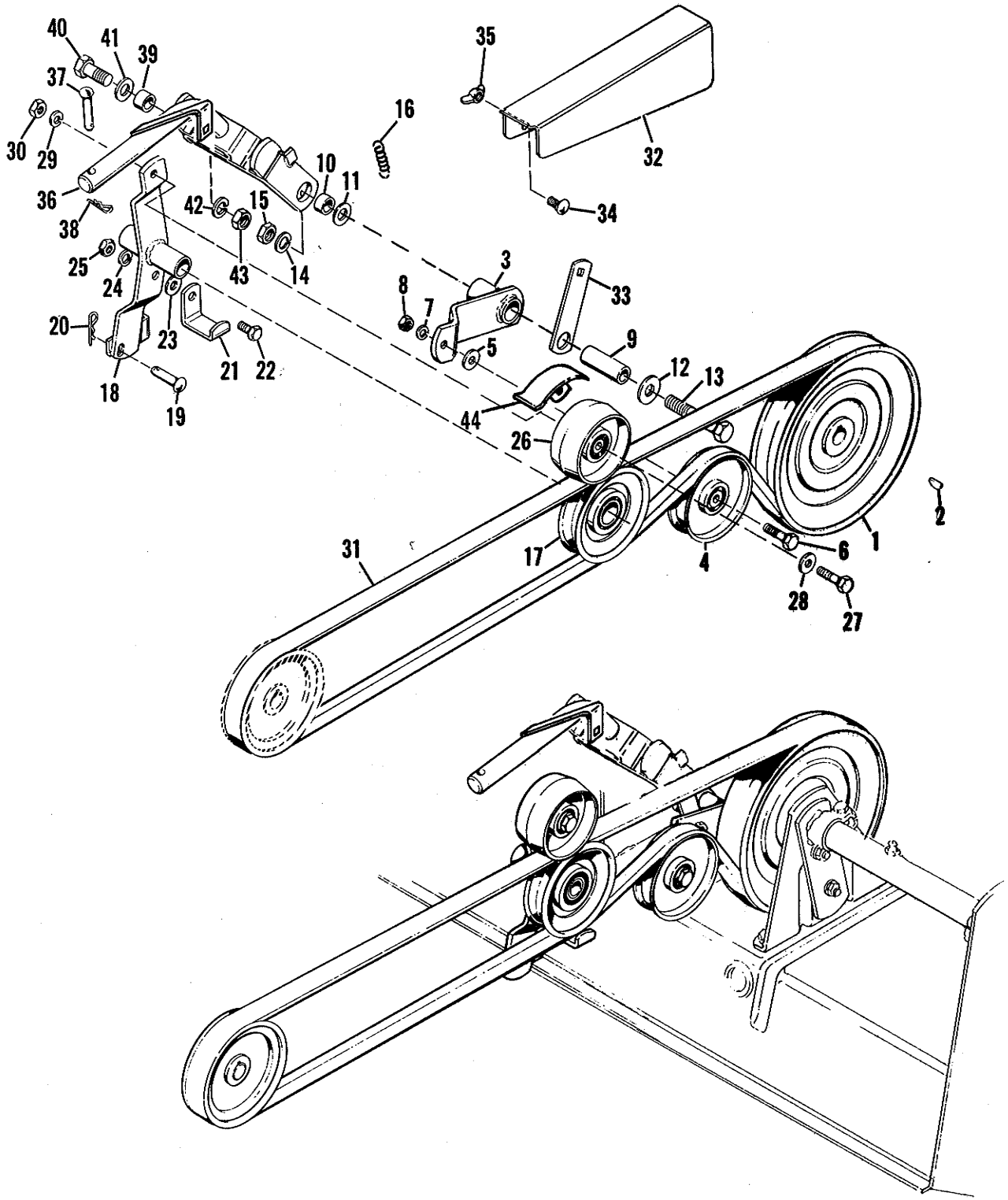

CLUTCH AND BELT DRIVE

Ref. No.	Part No.	Qty.	Description	Ref. No.	Part No.	Qty.	Description
1	105302	1	PULLEY	23	917642	1	WASHER, Plain, 3/8"
2	905123	1	KEY	24	916965	1	LOCKWASHER, 3/8"
3	1652567	1	CLUTCH LEVER ASSEMBLY	25	916950	1	NUT, Hex, Full, 3/8"-16
4	105306	1	PULLEY, Idler	26	164083	1	PULLEY, Idler
5	917642	1	WASHER, Plain, 5/16"	27	919361	1	CAPSCREW, Hex 3/8"-16 x 1-1/4" lg.
6	930573	1	CAPSCREW, Hex 3/8"-16 x 3" lg.	28	917642	1	WASHER, Plain, 3/8"
7	916965	1	LOCKWASHER, 3/8"	29	916965	1	LOCKWASHER, 3/8"
8	916950	1	NUT, Hex, Full, 3/8"-16	30	916950	1	NUT, Hex, Full, 3/8"-16
9	105339	1	SPACER	31	105340	1	"V" BELT
10	105346	1	SPACER	32	105326	1	GUARD, Belt
11	917378	1	WASHER, Plain, 3/8"	33	105359	1	SUPPORT, Belt Guard
12	918430	1	WASHER, Plain, 7/16"	34	920562	2	BOLT, Carriage 5/16"-18 x 3/4" lg.
13	926111	1	CAPSCREW, Hex 7/16"-14 x 3-1/2" lg.	35	927557	1	NUT, Flange, 5/16"-18
14	918199	1	LOCKWASHER, 7/16"	36	1652573	1	LIFT BAR ASSEMBLY
15	918213	1	NUT, Hex, Jam, 7/16"-14	37	118053	1	PIN
16	174896	1	SPRING	38	106787	1	CLIP, Spring
17	105380	1	PULLEY, Idler	39	105346	1	SPACER
18	1692576	1	IDLER ARM ASSEMBLY	40	916432	1	CAPSCREW, Hex 7/16"-14 x 1-1/4" lg.
19	105306	1	PIN	41	917378	1	WASHER, Plain, 3/8"
20	106787	1	CLIP, Spring	42	918199	1	LOCKWASHER, 7/16"
21	105351	1	GUARD, Belt	43	918213	1	NUT, Hex, Jam, 7/16"-14
22	919357	1	CAPSCREW, Hex 3/8"-16 x 7/8" lg.	44	176366	1	GUARD

HITCH AND HEIGHT ADJUSTMENT

Ref. No.	Part No.	Qty.	Description
1	1652583	1	HITCH ASSEMBLY
2	105386	2	SPACER
3	918431	4	WASHER, Plain, 1/2"
4	917279	2	CAPSCREW, Hex 1/2"-13 x 1-1/4" lg.
5	922184	2	NUT, Hex, Full Lock, 1/2"-13
6	155037	2	PIN
7	106787	2	CLIP, Spring
8	1652584	1	ADJUSTER ASSEMBLY
9	118335	2	SPACER
10	917400	2	CAPSCREW, Hex 3/8"-16 x 1-1/4" lg.
11	917378	2	WASHER, Plain, 3/8"
12	916969	2	LOCKWASHER, 3/8"
13	916950	2	NUT, Hex, Full, 3/8"-16
14	152050	1	GUIDE, Rod
15	121175	1	LINER, Guide
16	907729	1	CAPSCREW, Hex 5/16"-18 x 1-1/4" lg.
17	923362	1	NUT, Hex, Full Lock 5/16"-18
18	108415	1	ADJUSTING SCREW ASSEMBLY
19	917378	1	WASHER, Plain, 3/8"
20	105201	1	COLLAR, Set
21	930545	1	SCREW, Set 1/4"-20 x 5/16" lg.
22	108172	1	PIVOT
23	917642	1	WASHER, Plain, 5/16"
24	918447	1	PIN, Cotter 3/32" x 3/4" lg.
25	172676	2	WHEEL & TIRE ASSEMBLY
26	172682	2	BOLT, Wheel
27	924058	2	NUT, Hex, Full Lock 7/16"-14
28	172317	1	BAR, Tow
29	172316	1	REINFORCER, Tow Bar
30	921158	1	BOLT, Carriage 5/16"-18 x 1" lg.
31	923346	3	BOLT, Carriage 5/16"-18 x 3/4" lg.
32	917356	4	LOCKWASHER, 5/16"
33	917372	4	NUT, Hex, Full 5/16"-18
34	103031	1	DECAL, Safety (Not Illustrated)

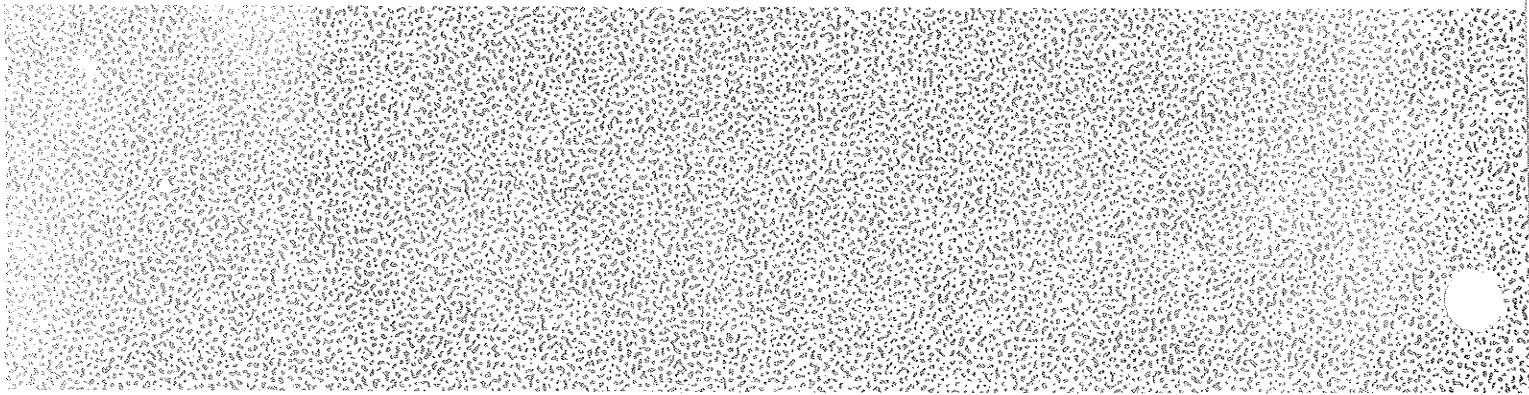

ONCE EACH YEAR

Once a year remove the chain cover on the left side of the revitalizer housing and inspect the chain. If the chain shows excessive wear, it should be replaced. See your dealer for the correct chain.

If the chain is loose it should be tightened until all slack is removed. See Adjustments.

Coat the chain liberally with automotive grease and replace the cover.

BELT REPLACEMENT

If the revitalizer drive belt should become excessively frayed or twisted or break and replacement is necessary, do the following:

1. Be sure the tractor engine is not running.
2. Place the power-take-off in the disengaged position.
3. Remove the two hex nuts holding the belt guard in place over the drive belt. Remove the belt guard.
4. See Figure 6. Remove the belt guard and idler pulley from the reverse idler assembly and replace the damaged belt with a new belt.
5. When replacing the belt guard, position it so the belt will not rub against it when the revitalizer is operated.
6. Place the new belt over the revitalizer pulley and replace the belt guard.
7. Install the belt over the power-take-off pulley and check that all things are assembled as mentioned in this manual and your tractor manual.

