

TABLE OF CONTENTS

MICROWAVE HOOD COMBINATION SAFETY	3	MANUAL COOKING	16
Electrical Requirements	4	Add a Minute	16
PARTS AND FEATURES	5	Micro Time/Power Cooking	16
Oven Cavity Coating	5	Manual Method Cooking.....	16
Microwave System – OPTIMAWAVE™ Technology	5	Keep Warm.....	17
Turntable	6	Cooking in Stages (or steps).....	17
ACCESSORIES	6	PROGRAMMED COOKING	18
Cooking Rack.....	6	Sensor Cooking.....	18
Browning Pan and Handle	6	Preheating	18
OVEN CONTROL	7	Doneness.....	18
Control Panel.....	7	Popcorn	18
Interactive Touch Display.....	7	Using Food Type	18
Main Menu.....	8	Using Cook Method	18
Settings & Info	9	Reheat	19
Clock	10	Defrost	19
Date	10	Cook	19
Demo Mode.....	10	Boil & Simmer	19
Display Backlight.....	10	Browning Pan	20
Display Contrast.....	10	Melt.....	20
Learning Mode	11	Soften	20
Tones.....	11	Steam Cook.....	20
Start	11	Most Used Menu	20
Off.....	11	Food Type Chart	21
Clear	11	Cook Method Chart.....	24
Timer.....	12	OVEN CARE	27
Control Lock.....	12	General Cleaning	27
TRUCAPTURE™ Vent Fan and Cooktop Lights	13	Replacing Filters.....	28
Cooking Animation.....	13	Replacing Cooktop Light	29
Progress Bar.....	13	Replacing Oven Light.....	29
OVEN USE	14	TROUBLESHOOTING	30
Food Characteristics	14	ASSISTANCE OR SERVICE	31
Cooking Guidelines	14	Replacement Parts.....	31
Cookware and Dinnerware	15	WARRANTY	32
Aluminum Foil and Metal	15		
Microwave Cooking Power	15		

MICROWAVE HOOD COMBINATION SAFETY

Your safety and the safety of others are very important.

We have provided many important safety messages in this manual and on your appliance. Always read and obey all safety messages.



This is the safety alert symbol.

This symbol alerts you to potential hazards that can kill or hurt you and others.

All safety messages will follow the safety alert symbol and either the word “DANGER” or “WARNING.”

These words mean:

⚠ DANGER

You can be killed or seriously injured if you don't immediately follow instructions.

⚠ WARNING

You can be killed or seriously injured if you don't follow instructions.

All safety messages will tell you what the potential hazard is, tell you how to reduce the chance of injury, and tell you what can happen if the instructions are not followed.

IMPORTANT SAFETY INSTRUCTIONS

When using electrical appliances basic safety precautions should be followed, including the following:

WARNING: To reduce the risk of burns, electric shock, fire, injury to persons, or exposure to excessive microwave energy:

- Read all instructions before using the microwave oven.
- Read and follow the specific “PRECAUTIONS TO AVOID POSSIBLE EXPOSURE TO EXCESSIVE MICROWAVE ENERGY” found in this section.
- The microwave oven must be grounded. Connect only to properly grounded outlet. See “GROUNDING INSTRUCTIONS” found in this section and in the provided Installation Instructions.
- Install or locate the microwave oven only in accordance with the provided Installation Instructions.
- Some products such as whole eggs in the shell and sealed containers – for example, closed glass jars – are able to explode and should not be heated in the microwave oven.
- Use the microwave oven only for its intended use as described in this manual. Do not use corrosive chemicals or vapors in the microwave oven. This type of oven is specifically designed to heat, cook, or dry food. It is not designed for industrial or laboratory use.
- As with any appliance, close supervision is necessary when used by children.
- Do not operate the microwave oven if it has a damaged cord or plug, if it is not working properly, or if it has been damaged or dropped.
- The microwave oven should be serviced only by qualified service personnel. Call an authorized service company for examination, repair, or adjustment.
- See door surface cleaning instructions in the “Microwave Oven Care” section.
- To reduce the risk of fire in the oven cavity:
 - Do not overcook food. Carefully attend the microwave oven when paper, plastic, or other combustible materials are placed inside the oven to facilitate cooking.
 - Remove wire twist-ties from paper or plastic bags before placing bags in oven.
 - If materials inside the oven ignite, keep oven door closed, turn oven off, and disconnect the power cord, or shut off power at the fuse or circuit breaker panel.
 - Do not use the cavity for storage purposes. Do not leave paper products, cooking utensils, or food in the cavity when not in use.
- Liquids, such as water, coffee, or tea are able to be overheated beyond the boiling point without appearing to be boiling. Visible bubbling or boiling when the container is removed from the microwave oven is not always present. THIS COULD RESULT IN VERY HOT LIQUIDS SUDDENLY BOILING OVER WHEN THE CONTAINER IS DISTURBED OR A SPOON OR OTHER UTENSIL IS INSERTED INTO THE LIQUID.
 - To reduce the risk of injury to persons:
 - Do not overheat the liquid.
 - Stir the liquid both before and halfway through heating it.
 - Do not use straight-sided containers with narrow necks.
 - After heating, allow the container to stand in the microwave oven for a short time before removing the container.
 - Use extreme care when inserting a spoon or other utensil into the container.
- Oversized foods or oversized metal utensils should not be inserted in the microwave oven as they may create a fire or risk of electric shock.
- Do not clean with metal scouring pads. Pieces can burn off the pad and touch electrical parts involving a risk of electric shock.

SAVE THESE INSTRUCTIONS

IMPORTANT SAFETY INSTRUCTIONS

- Suitable for use above both gas and electric cooking equipment.
- Intended to be used above ranges with maximum width of 36" (91.44 cm).
- Clean Ventilating Hoods Frequently - Grease should not be allowed to accumulate on hood or filter.
- Do not use paper products when appliance is operated in the "PAN BROWN" mode (on models with this feature).
- Do not store any materials, other than manufacturer's recommended accessories, in this oven when not in use.
- Do not store anything directly on top of the microwave oven when the microwave oven is in operation.
- When flambeing foods under the hood, turn the fan on.
- Use care when cleaning the vent-hood filter. Corrosive cleaning agents, such as lye-based oven cleaners, may damage the filter.
- Do not cover or block any openings on the microwave oven.
- Do not store this microwave oven outdoors. Do not use the microwave oven near water - for example, near a kitchen sink, in a wet basement, or near a swimming pool, or similar locations.
- Do not immerse cord or plug in water.
- Keep cord away from heated surfaces.
- Do not let cord hang over edge of table or counter.
- Do not mount over a sink.
- Do not cover racks or any other part of the oven with metal foil. This will cause overheating of the oven.

SAVE THESE INSTRUCTIONS

PRECAUTIONS TO AVOID POSSIBLE EXPOSURE TO EXCESSIVE MICROWAVE ENERGY

- (a) Do not attempt to operate this oven with the door open since open-door operation can result in harmful exposure to microwave energy. It is important not to defeat or tamper with the safety interlocks.
- (b) Do not place any object between the oven front face and the door or allow soil or cleaner residue to accumulate on sealing surfaces.
- (c) Do not operate the oven if it is damaged. It is particularly important that the oven door close properly and that there is no damage to the:
 - (1) Door (bent),
 - (2) Hinges and latches (broken or loosened),
 - (3) Door seals and sealing surfaces.
- (d) The oven should not be adjusted or repaired by anyone except properly qualified service personnel.

Electrical Requirements

⚠ WARNING



Electrical Shock Hazard

- Plug into a grounded 3 prong outlet.**
- Do not remove ground prong.**
- Do not use an adapter.**
- Do not use an extension cord.**
- Failure to follow these instructions can result in death, fire, or electrical shock.**

Observe all governing codes and ordinances.

Required:

- A 120 Volt, 60 Hz, AC only, 15- or 20-amp electrical supply with a fuse or circuit breaker.

Recommended:

- A time-delay fuse or time-delay circuit breaker.
- A separate circuit serving only this appliance.

GROUNDING INSTRUCTIONS

- **For all cord connected appliances:**
The microwave oven must be grounded. In the event of an electrical short circuit, grounding reduces the risk of electric shock by providing an escape wire for the electric current. The microwave oven is equipped with a cord having a grounding wire with a grounding plug. The plug must be plugged into an outlet that is properly installed and grounded.

WARNING: Improper use of the grounding plug can result in a risk of electric shock. Consult a qualified electrician or serviceman if the grounding instructions are not completely understood, or if doubt exists as to whether the microwave oven is properly grounded.

Do not use an extension cord. If the power supply cord is too short, have a qualified electrician or serviceman install an outlet near the microwave oven.

SAVE THESE INSTRUCTIONS

This device complies with Part 18 of the FCC Rules.

PARTS AND FEATURES

This manual may cover several different models. The model you have purchased may have some or all of the features shown here. The appearance of your particular model may differ slightly from the illustrations in this manual.

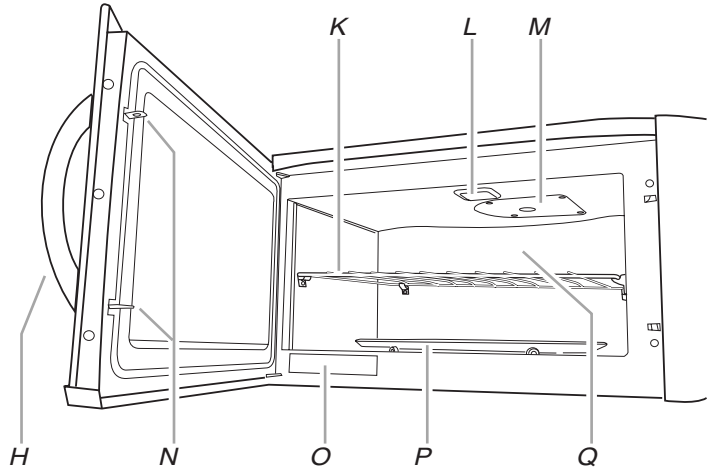
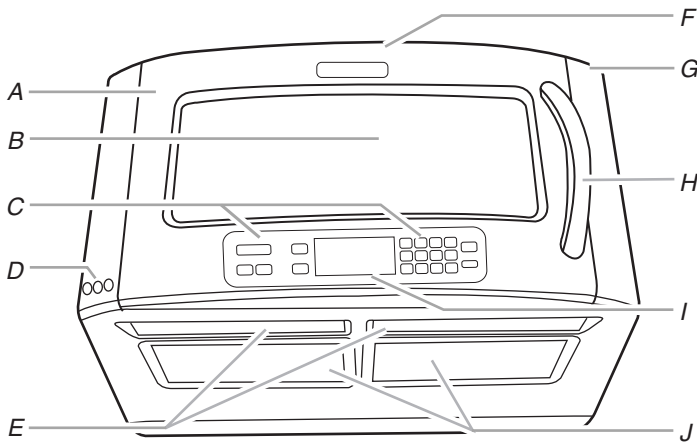

- A. Oven door
- B. Metal-shielded window
- C. Control panel
- D. Fan, Light and Night Light buttons
- E. Halogen cooktop lights (2)

- F. Exhaust vent (for recirculation) (top surface of oven)
- G. Intake vent
- H. Door handle
- I. Interactive touch display
- J. Grease and charcoal filters (2 each)

- K. Cooking rack
- L. Oven light
- M. Microwave inlet cover
- N. Door lock system

- O. Model and serial number plate
- P. Turntable
- Q. Cavity recess

Oven Cavity Coating

The oven has a durable, nonstick coating that resists soil buildup by making cleaning easier than in conventional microwave ovens. See "General Cleaning" section for cleaning instructions.

Microwave System – OPTIMAWAVE™ Technology

The microwave system featuring OPTIMAWAVE™ Technology delivers a constant stream of microwave power – true high, medium and low power – to provide consistent, even results.

Typically, microwave ovens operate on HIGH power only. For example, to achieve a 50% power level ("medium") in a typical microwave oven, the oven operates 50% of the time at HIGH power and 50% of the time OFF.

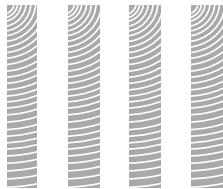

In contrast, microwave ovens utilizing this microwave system deliver the selected power level continuously. This constant stream of microwave power helps to minimize overcooking of foods and messy food spatters.



Sensor Cooking

The microwave system features sensor cooking functions. A humidity sensor in the oven cavity detects moisture and humidity emitted from food as it heats. The sensor adjusts cooking times to various types and amounts of food. Sensor cooking takes the guesswork out of microwave cooking.

Turntable

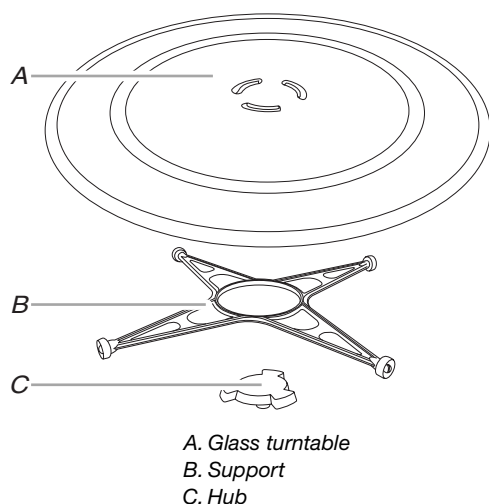

The turntable can rotate in either direction to help cook food more evenly. Do not operate the oven without having the turntable in place. See “Assistance or Service” to reorder any of the parts.

To Install:

1. Place the support on the oven cavity bottom.
2. Place the turntable on the support.
Fit the raised, curved lines in the center of the turntable bottom between the three spokes of the hub. The rollers on the support should fit inside the turntable bottom ridge.

Turning Off the Turntable

The turntable can be turned off for manual cooking cycles only. This is helpful when cooking with plates that are larger than the turntable, or when cooking with two plates that are side by side. When the manual cycle is over, the turntable will automatically default to the “ON” mode.

To Turn On/Off:

1. Touch TURNTABLE (ON/OFF).
The display shows the Turntable On/Off screen.

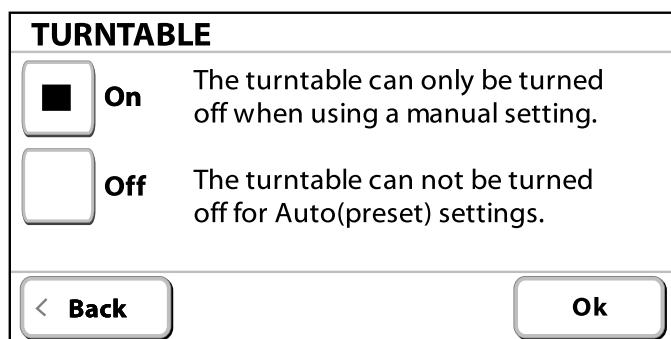

2. Select “Off,” then touch “OK.”
The turntable off indicator will appear on the display.
Repeat to turn the turntable back on.

ACCESSORIES

The following accessories have been provided with your new oven. Any of the parts may be ordered for replacement.

Cooking Rack

The rectangular cooking rack is ideal for two-level cooking. It provides extra cavity space for cooking 2 or more containers at the same time. Insert the rack securely into the rack supports on the side walls of the oven. See “Assistance or Service” to order replacement parts.

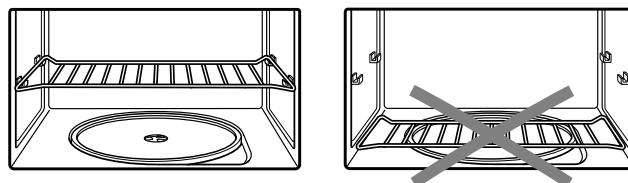

- When not using the rack for cooking, remove it from the oven. Damage to the oven could result if someone unintentionally turns on the oven.
- Rack will become hot. Always use oven mitts or pot holders when handling.
- Do not allow the rack to touch the inside cavity walls, ceiling or floor.
- Use the rack only when cooking on 2 levels.
- Do not use metal cookware, utensils, or a browning dish with the rack.
- Do not let food container on rack touch the top or sides of the oven.
- Do not use browning pan on rack.
- Remove rack before using Popcorn function.
- Do not cook food directly on the rack. Always use a microwave-safe container.
- The rack is designed specifically for this oven. Do not attempt to use any other rack (besides those supplied with the oven) in this oven.
- Clean rack supports often (see “General Cleaning” section). Damage to the oven could result due to soil buildup.

Browning Pan and Handle

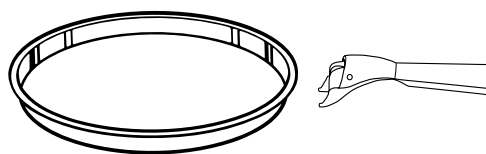

The browning pan, with its nonstick surface and detachable handle, has been specially designed for microwave use, and is ideal for pan-frying (pan-browning) foods in the microwave oven. See “Browning Pan Use” section.

Use the handle to grasp the pan. Place gripping end on the edge of pan, squeeze handle and lift pan. See “Assistance or Service” to order replacement parts. See “General Cleaning” for cleaning instructions.

OVEN CONTROL

The oven's controls are accessed through its control panel and interactive touch display.

NOTE: Due to the sensitivity of the control panel, we have provided special instructions for cleaning the panel as well as the touch screen display. See "General Cleaning" section for cleaning instructions.

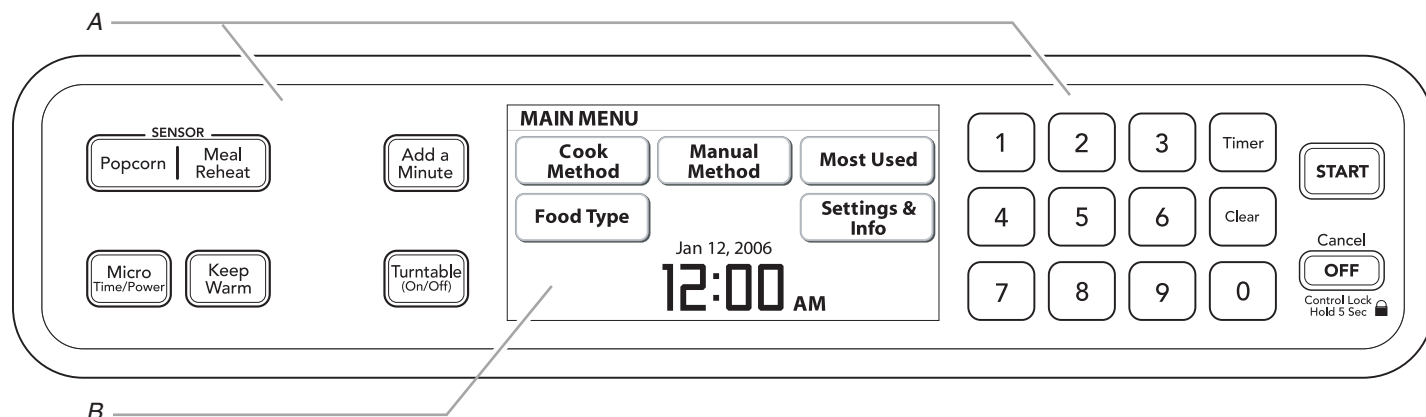

A. Control panel
B. Interactive touch display

Control Panel

The control panel houses basic controls and one-touch automatic function controls. The control pads are very sensitive, and require only a light touch to activate.

For more information about the individual controls, see their respective sections in this manual.

Interactive Touch Display

The display area functions as both a display and an interactive, menu-driven touch control. It is designed to be easily navigable, guiding you through the menus, offering multiple selections, accepting your input and executing your commands. It also provides instructions, tips, and graphics.

Display

When power is first supplied to the oven, the welcome screen appears, asking whether you would like to set the clock. Touch "Yes" and set the clock (see "Clock" section), or touch "No" and the time will default to 12:00 p.m. If the welcome screen appears at any other time, a power failure has occurred. Reset the clock if needed.

When the oven is not in use (in standby mode), the display shows the Main Menu and the date and time of day, if they are set to be displayed. See "Clock" and "Date" sections. After 2 minutes of inactivity, the display will go into sleep mode. See "Display Backlight" section.

During programming, the display shows menus, servings and weights, cooking time/power/temperature settings, preheating instructions, and/or cookware and preparation instructions.

During a cooking cycle, the display shows progress bar (sensor functions only, see "Progress Bar" section), cooking animation (see "Cooking Animation" section), and the countdown of cook time remaining. The display will also give prompts to tend to the food during certain automatic cycles.

Touch Screen

The LCD touch screen is used to make menu selections, adjust settings and input commands.

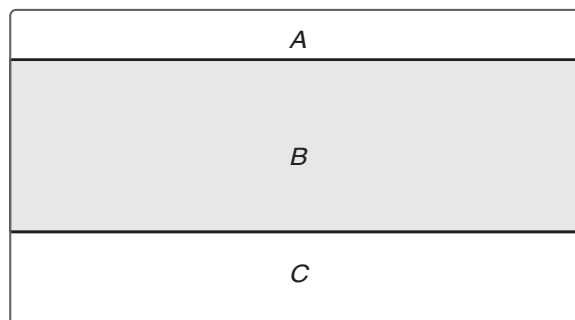

A. Title/description region
B. Menu and selection/settings input region
C. Command input region

Menu selections and input adjustments are made in the center portion of the screen, and the command inputs (start, continue, back, cancel, etc.) are made in the bottom portion of the screen. Screen titles and descriptions are displayed in the top portion of the screen, which accepts no input. A light- to medium-pressure touch of the fingertip will activate the menu choice.

Main Menu

The Main Menu is displayed on the default screen.

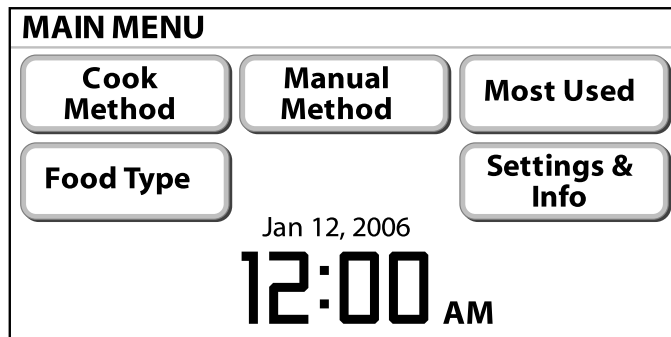

From the Main Menu, all automatic cooking programs can be activated; all manual cooking can be programmed; settings can be adjusted; and instructions, preparation and tips can be accessed.

The following demonstrates how to pan brown 2 boneless chicken breasts, using the Cook Method menus, starting from the Main Menu:

1. On Main Menu, touch "Cook Method."

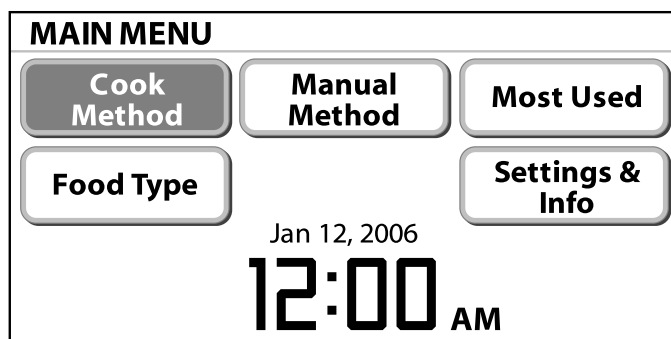

2. On Cook Method screen, touch "Browning Pan."

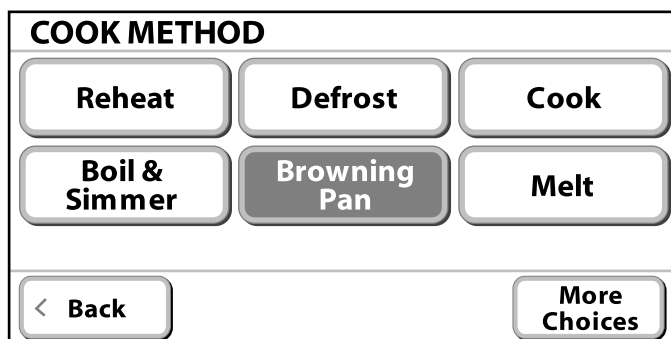

3. On Browning Pan screen, touch "Poultry Brst Boneless."

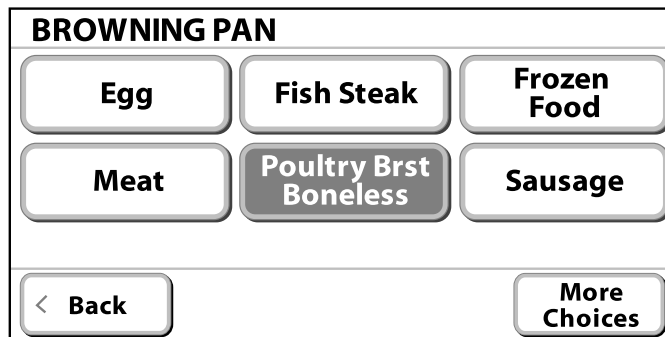

4. On Browning Pan-Poultry Breast screen, touch "2 pieces." Weight guidelines appear below the quantity selections.

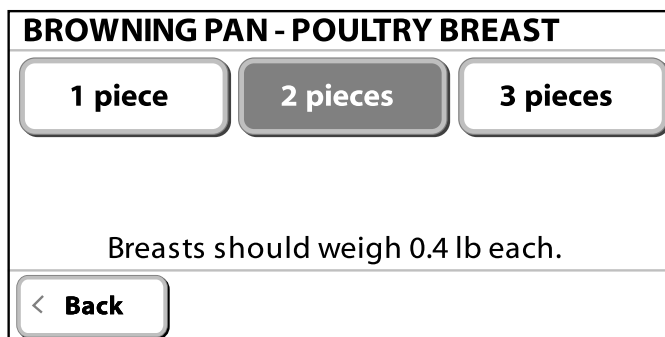

5. On Poultry Breast screen, follow the instructions, then touch "Start Preheat."

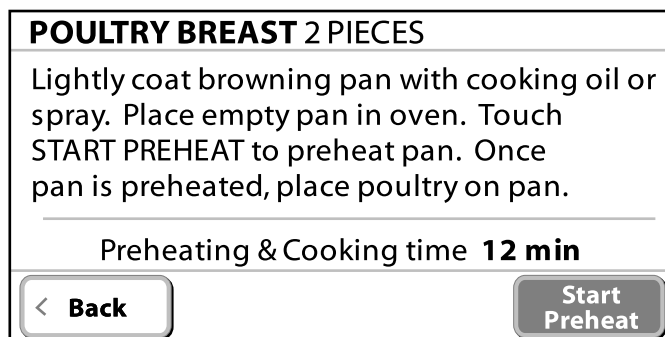

While the browning pan preheats, the cooking animation and countdown are active in the display.

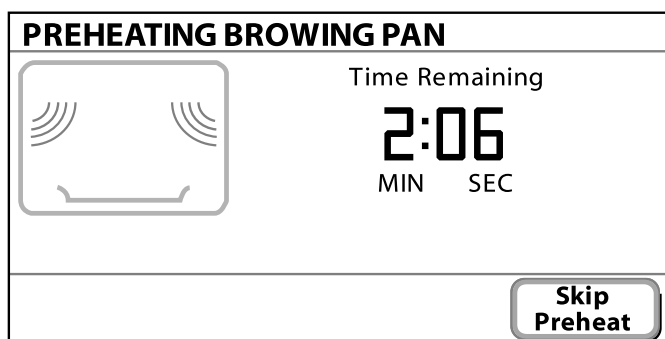

6. When preheating is finished, follow the instructions on the Preheat Finished screen, then touch “Continue.”
If more or less cook time is desired, adjust doneness before touching “Continue.”



While the poultry breasts are being pan browned, the cooking animation and countdown are active in the display.

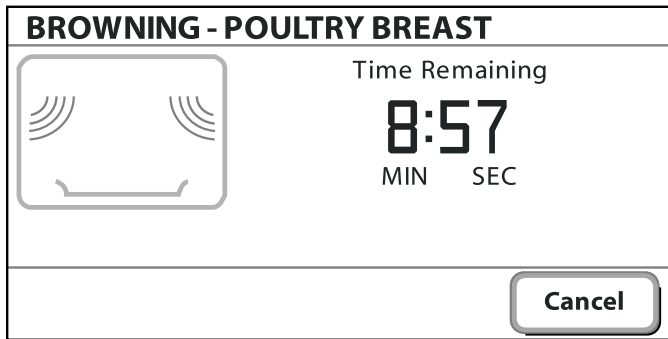

About halfway through the cycle, the oven will stop, and the display will direct you to turn over the poultry breasts.

7. Touch “Continue” to resume pan browning.
When the cycle is over, the Finished screen appears.

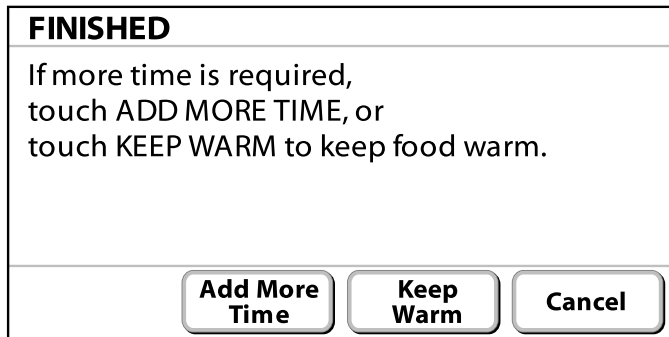

If you would like to either add more time or keep the food warm, you may do so at this time.

8. If the doneness is satisfactory, touch “Cancel” to return to the default screen.

The same cooking can also be accomplished using the “Food Type” menus instead of the “Cook Method” menu.

1. On Main Menu, touch “Food Type,” then “More Choices.”
2. Touch “Poultry,” and then “More Choices.”
3. Touch “Poultry Breast: Pan.”

This takes you to the same Browning Pan-Poultry Breast screen as in the Cook Method sequence.

4. Follow steps 4-8 in Cook Method sequence.

See “Learning Mode” section to see how to practice navigating through the menus without turning on the microwave generator.

Settings & Info

Oven features may be activated and/or changed, and display characteristics may be adjusted using the “Settings & Info” menu. Following is a brief description of each option.

OPTION	SETTING
Clock	<ul style="list-style-type: none"> ■ Turn Daylight Savings on or off. ■ Adjust time: set or hide clock. See “Clock” section.
Contact Info	<ul style="list-style-type: none"> ■ Find contact information: toll-free number and website.
Date	<ul style="list-style-type: none"> ■ Set date: month, day and year. ■ Hide date. See “Date” section.
Demo Mode	<ul style="list-style-type: none"> ■ View sales demonstration. See “Demo Mode” section.
Display Backlight	<ul style="list-style-type: none"> ■ Set backlight brightness: reduce after 2 minutes or turn off after 2 minutes. See “Display Backlight” section.
Display Contrast	<ul style="list-style-type: none"> ■ Set level of contrast between minimum and maximum using “+” and “-” controls. See “Display Contrast” section.
Hints	View comprehensive lists of hints for general operation and care of oven: <ul style="list-style-type: none"> ■ Cleaning: cavity, control panel, odors and turntable. ■ Cookware: covers, depth, materials and shape. ■ Food: eggs, moisture, quantity and shape. ■ Methods: arranging, covering, defrosting and standing. ■ Power levels: list of microwave power levels and sample foods for each.
Learning Mode	<ul style="list-style-type: none"> ■ Turn on or off. See “Learning Mode” section.
Volume	<ul style="list-style-type: none"> ■ Set tone volume using “+” and “-” controls. See “Tones” section.

1. On Main Menu, touch “Settings & Info.”
2. Touch desired option (touch “More Choices” for more categories), then follow the instructions on the screen to select and/or adjust settings.

Clock

This is a standard 12-hour clock (12:00 AM-11:59 PM). When power is first supplied to the oven, or after a power failure, the “Welcome” screen will appear, asking whether you would like to set the clock. If you choose to set the clock at that time, the display will take you directly to the Clock screen. If you choose not to set the clock, the time of day will default to 12:00 p.m., and the clock will be displayed and continue to keep time. The clock defaults to Daylight Savings OFF.

To Set Clock:

1. On Main Menu, touch “Settings & Info.”
2. On Settings & Info screen, touch “Clock.”
3. On Clock screen, set the time of day and date, if desired, and select AM or PM.

To Change Daylight Savings Setting: On Clock screen, select “Daylight Savings ON” or “Daylight Savings OFF,” then touch “OK.”

To Hide Clock: On Clock screen, touch “Hide Clock.” The display will immediately return to the Main Menu.

Date

The date may be set and displayed on the Main Menu screen. The default setting is Jan. 1.

To Set Date:

1. On Main Menu, touch “Settings & Info.”
2. On Settings & Info screen, touch “Date.”
3. On Date screen, use number pads to set the month, day and year.

To Hide Date: On Date screen, touch “Hide Date.” The display will immediately return to the Main Menu. Repeat to display the date.

Demo Mode

The Demo Mode highlights the features and capabilities of the oven in a slide show on the display.

To Activate Demo Mode:

1. On the Main Menu, touch “Settings & Info.”
2. On Settings & Info screen, touch “Demo Mode.”
The demonstration immediately begins. You can move forward or back in the demonstration by touching “Next Page” or “Back,” or wait for the screen to advance. When the demonstration is over, it automatically loops back to the beginning and starts again.
3. Touch “Cancel” on the touch screen, or touch OFF control to cancel Demo Mode and return the display to the Main Menu.

Display Backlight

Display backlight may be set to reduce brightness or to turn off during sleep mode.

Sleep mode is an energy-saving feature that darkens the display backlight after 2 minutes of inactivity. During sleep mode, only the time and date are visible, along with instruction to touch the screen to reactivate the Main Menu.

To Set Display Backlight:

1. On Main Menu, touch “Settings & Info.”
 2. Touch “Display Backlight.”
 3. Select setting: reduce after 2 minutes or off after 2 minutes.
 4. Touch “OK.”
-

Display Contrast

Display contrast has numerous settings, ranging from minimum to maximum.

To Set Display Contrast:

1. On Main Menu, touch “Settings & Info.”
2. Touch “Display Contrast.”
3. Using “+” and “-” controls, increase or decrease the contrast.
4. Touch “OK.”

Learning Mode

The Learning Mode is ideal for learning how to use the oven. When set, functions can be entered, with real displays and tones, without actually turning on the microwave generator (magnetron). While functions are operating in the Learning Mode, the oven light will come on, the fan will run, and the turntable will rotate (if set ON).

While the Learning Mode is active, the Learn indicator is visible in the upper, right title area, or at the bottom command input area. The indicator is visible while the oven is in standby mode, during programming, and during Settings & Info menu navigation. During a “practice” cooking cycle, the Learn indicator is visible in the lower, left command input area.

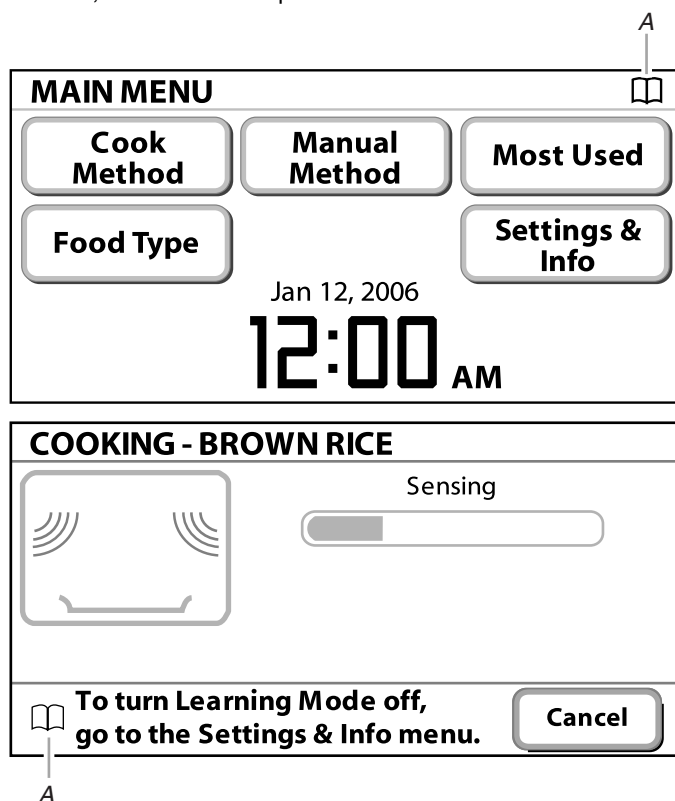

A. Indicators for Learning Mode

To Activate Learning Mode:

1. On the Main Menu, touch “Settings & Info.”
2. On Settings & Info screen, touch “More Choices.”
3. Touch “Learning Mode.”
4. Touch “On” or “Off” to set.
5. Touch “OK.”

Tones

Tones are audible signals, indicating the following:

One Tone

- Valid entry (short tone)

Two Tones

- Between stages (short tones)
- Reminder (long tones), repeat each minute for 10 minutes after the end-of-cycle tones
- End of Timer countdown
- Hidden feature entered or exited (very short, quick tones)

Three Tones

- Invalid entry (very short, quick tones)
- Retry Error

Four Tones

- End of cycle (2 short tones, followed by 2 longer tones)
- Interruption, tend to food (short tones)
- Attention - door needs to be opened and closed

To Adjust Tone Volume:

1. On Main Menu, touch “Settings & Info.”
2. On Settings & Info screen, touch “More Choices.”
3. Touch “Volume.”
4. Using “+” and “-” controls, increase or decrease the volume setting, or turn the tones off.
5. Touch “OK.”

Start

The START control will start any function.

If non-sensor cooking is interrupted, touching the START control pad will resume the preset cycle.

For added convenience, the “Start” touch pad is also available on some display screens, and provides the same function as the START control pad.

Off

The OFF control stops all functions except for the Timer and Learning Mode, and cancels programming in progress.

The oven will also turn off when the door is opened. Close the door and touch START control or “Continue” on the touch screen to resume the cycle. A sensor cooking cycle may not be resumed if interrupted by opening the door.

Clear

During programming, the CLEAR control changes the numeric programming values, such as minutes, seconds and cook power that are active in the display to their default value. For example, while entering a cook time, touching CLEAR will change the time you have already entered to “0:00.” The CLEAR control gives an invalid signal (see “Tones” section) if touched during cooking.

Timer

The Timer can be set in minutes and seconds, up to 99 minutes, and counts down the set time.

NOTE: The Timer does not start or stop the oven.

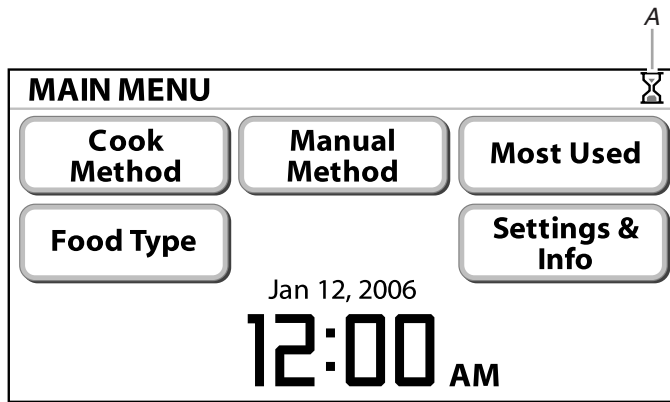

A. Timer indicator

While the Timer is in use, the oven can still operate. During an oven operation, the Timer countdown will be minimized. If the Timer ends while oven is still operating, the end-of-Timer tones will sound, and the set operating mode will remain active on the screen.

To Set Timer:

1. Touch TIMER control.
2. Using the number pads, enter desired time in minutes and seconds, and then touch "Start Timer."

The countdown will be in full screen view.

3. Touch "OK" to minimize the timer.

To see the countdown in full screen view, touch TIMER control.

The time can be reset during the countdown by touching TIMER, entering a new time, then touching "OK," or the START control.

To Cancel: Touch TIMER control, then touch "Cancel Timer."

Control Lock

The Control Lock disables all controls to prevent unintended use of the oven. The only control that will function while the Control Lock is active is the OFF pad on the control panel.

Control Lock activation is possible only when the display is at the Main Menu.

To Activate Control Lock: Touch and hold OFF control for 5 seconds. Two tones will sound, and the display will show the padlock icon.

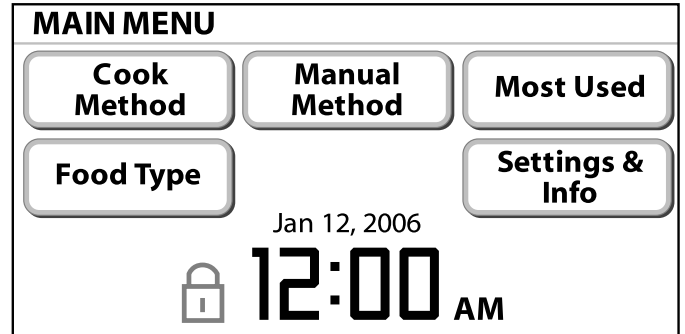

If any controls are touched while the Control Lock is active, the "Control Lock" reminder screen appears for 5 seconds.

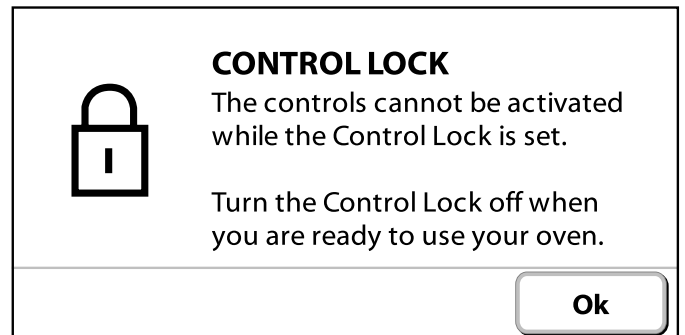

To Deactivate Control Lock: Touch and hold OFF control for 5 seconds. Two tones will sound, and the padlock icon will be removed from the display.

TRUCAPTURE™ Vent Fan and Cooktop Lights

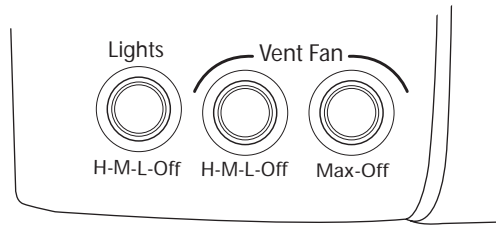

The oven's hood controls, on the lower, left side of the oven (see "Parts and Features") operate the vent fan and cooktop lights.

TRUCAPTURE™ Vent Fan

The vent fan has 3 regular speeds: high, medium and low. The vent fan also has a max speed, which is the highest speed.

To protect the oven, the vent fan will automatically turn on at high speed if the temperature from the cooking surface below gets too hot. It may stay on for up to 1 hour to cool the oven. When this occurs, the vent fan cannot be turned off. After the oven has cooled, the vent fan will automatically turn off.

NOTE: For optimal TRUCAPTURE™ vent system performance, turn on the vent fan before using the cooking surface below. This will maximize steam capture.

To Operate Vent Fan: Press VENT FAN H-M-L-OFF repeatedly to cycle through the settings: high, medium, low and off. Touch VENT FAN MAX-OFF to turn on the max speed. The status will be displayed for a few seconds while the settings are being adjusted.

Cooktop Lights

The cooktop lights have 3 brightness settings: high, medium and low.

To Turn Light On/Off: Press LIGHTS button repeatedly to cycle through the settings: high, medium, low and off. The status will be displayed for a few seconds while the settings are being adjusted.

Cooking Animation

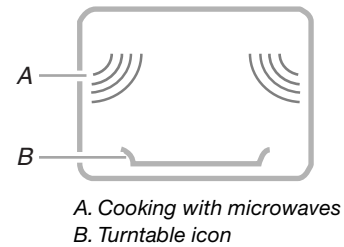

A. Cooking with microwaves
B. Turntable icon

The cooking animation appears during any cooking cycle, whether automatic or manual. The animation shows what type of cooking is taking place.

Progress Bar

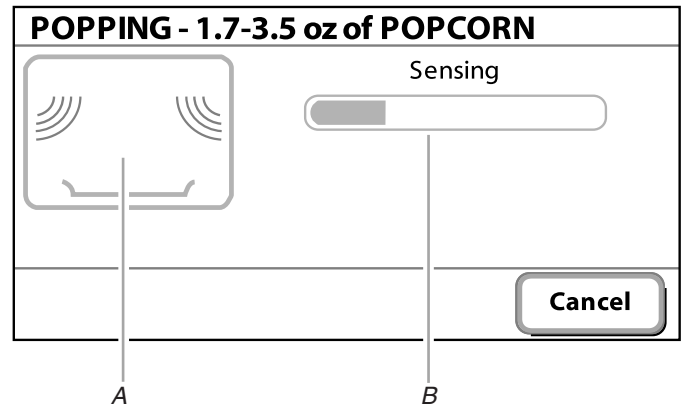

A. Cooking animation
B. Progress bar

The progress bar is a visual picture of the estimated running time of a sensor cooking cycle. It will appear at the beginning of sensor cooking functions. A horizontal bar appears below the word "Sensing," and shows progress by the darkening of the bar left to right. Some time after the progress bar appears, it may be replaced by "Maximum Time Remaining" indicator and the estimated remaining time, which may fluctuate often. When sensing is finished, "Time Remaining" will appear with the actual remaining cook time.

OVEN USE

A magnetron in the oven produces microwaves which reflect off the metal floor, walls and ceiling and pass through the turntable and appropriate cookware to the food. Microwaves are attracted to and absorbed by fat, sugar and water molecules in the food, causing them to move, producing friction and heat which cooks the food.

- Do not lean on or allow children to swing on the oven door.
- Do not operate oven when it is empty.
- The turntable must be in place and correct side up when oven is in use. Do not use if turntable is chipped or broken. See “Assistance or Service” section to reorder.
- Baby bottles and baby food jars should not be heated in oven.
- Clothes, flowers, fruit, herbs, wood, gourds, paper, including brown paper bags and newspaper, should not be dried in oven.
- Do not use the oven for canning, sterilizing or deep frying.
- Paraffin wax will not melt in the oven because it does not absorb microwaves.
- Use oven mitts or pot holders when removing containers from oven.
- Do not overcook potatoes. At the end of the recommended cook time, potatoes should be slightly firm. Let potatoes stand for 5 minutes. They will finish cooking while standing.
- Do not cook or reheat whole eggs inside the shell. Steam buildup in whole eggs may cause them to burst. Cover poached eggs and allow a standing time.

Food Characteristics

When microwave cooking, the amount, size and shape, starting temperature, composition and density of the food affect cooking results.

Amount of Food

The more food heated at once, the longer the cook time needed. Check for doneness and add small increments of time if necessary.

Size and Shape

Smaller pieces of food will cook more quickly than larger pieces, and uniformly shaped foods cook more evenly than irregularly shaped food.

Starting Temperature

Room temperature foods will heat faster than refrigerated foods, and refrigerated foods will heat faster than frozen foods.

Composition and Density

Foods high in fat and sugar will reach a higher temperature, and will heat faster than other foods. Heavy, dense foods, such as meat and potatoes, require a longer cook time than the same size of a light, porous food, such as cake.

Cooking Guidelines

Covering

Covering food helps retain moisture, shorten cook time and reduce spattering. Use the lid supplied with cookware. If a lid is not available, wax paper, paper towels or plastic wrap approved for microwave ovens may be used. Plastic wrap should be turned back at one corner to provide an opening to vent steam. Condensation on the door and cavity surfaces is normal during heavy cooking.

Stirring and Turning

Stirring and turning redistribute heat evenly to avoid overcooking the outer edges of food. Stir from outside to center. If possible, turn food over from bottom to top.

Arranging

If heating irregularly shaped or different sized foods, arrange the thinner parts and smaller sized items toward the center. If cooking several items of the same size and shape, place them in a ring pattern, leaving the center of the ring empty.

Piercing

Before heating, use a fork or small knife to pierce or prick foods that have a skin or membrane, such as potatoes, egg yolks, chicken livers, hot dogs, and sausage. Prick in several places to allow steam to vent.

Shielding

Use small, flat pieces of aluminum foil to shield the thin pieces of irregularly shaped foods, bones and foods such as chicken wings, leg tips and fish tail. See “Aluminum Foil and Metal” first.

Standing Time

Food will continue to cook by the natural conduction of heat even after the microwave cooking cycle ends. The length of standing time depends on the volume and density of the food.

Cookware and Dinnerware

Cookware and dinnerware must fit on the turntable. Always use oven mitts or pot holders when handling because any dish may become hot from heat transferred from the food. Do not use cookware and dinnerware with gold or silver trim. Use the following chart as a guide, then test before using.

MATERIAL	RECOMMENDATIONS
Aluminum Foil, Metal	See "Aluminum Foil and Metal" section.
Browning Dish	Bottom must be at least 3/16" (5 mm) above the turntable. Follow manufacturer's recommendations.
Ceramic Glass, Glass	Acceptable for use.
China, Earthenware	Follow manufacturer's recommendations.
Melamine	Follow manufacturer's recommendations.
Paper: Towels, Dinnerware, Napkins	Use nonrecycled and those approved by the manufacturer for microwave oven use.
Plastic: Wraps, Bags, Covers, Dinnerware, Containers	Use those approved by the manufacturer for microwave oven use.
Pottery and Clay	Follow manufacturer's recommendations.
Styrofoam [†]	Do not use in oven.
Silicone Bakeware	Follow manufacturer's recommendations.
Straw, Wicker, Wooden Containers	Do not use in oven.
Wax Paper	Acceptable for use.

To Test Cookware or Dinnerware for Microwave Use:

- Place cookware or dinnerware in oven with 1 cup (250 mL) of water beside it.
 - Cook at 100% cooking power for 1 minute.
- Do not use cookware or dinnerware if it becomes hot and the water stays cool.

Aluminum Foil and Metal

Always use oven mitts or pot holders when removing dishes from the oven.

Aluminum foil and some metal can be used in the oven. If not used properly, arcing (a blue flash of light) can occur and cause damage to the oven.

OK for Use

Racks and bakeware supplied with the oven (on some models), aluminum foil for shielding, and approved meat thermometers may be used with the following guidelines:

- Do not allow aluminum foil or metal to touch the inside cavity walls, ceiling or floor.

- Always use the turntable.
- Do not allow contact with another metal object during microwave cooking.

Do Not Use

Metal cookware and bakeware, gold, silver, pewter, non-approved meat thermometers, skewers, twist ties, foil liners such as sandwich wrappers, staples and objects with gold or silver trim or a metallic glaze should not be used in the oven.

Microwave Cooking Power

Many recipes for microwave cooking specify which cooking power to use by percent, name or number. For example, 70%=7=Medium-High.

Use the following chart as a general guide for the suggested cooking power of specific foods.

PERCENT/NAME	USE
100%, High (default setting)	Quick heating convenience foods and foods with high water content, such as soups, beverages and most vegetables.
90%	Cooking small tender pieces of meat, ground meat and poultry pieces. Heating cream soups.
80%	Heating rice, pasta or casseroles. Cooking and heating foods that need a cook power lower than high, such as meat loaf.
70%, Medium-High	Reheating a single serving of food. Cooking fish fillets.
60%	Cooking sensitive foods such as cheese and egg dishes, pudding and custards. Cooking non-stirring casseroles, such as lasagna.
50%, Medium	Cooking ham, whole poultry, whole fish and pot roasts. Simmering stews.
40%	Heating bread, rolls and pastries.
30%, Medium-Low	Melting chocolate, butter and marshmallows.
20%	Defrosting bread, fish, meats, poultry and precooked foods. Softening ice cream, butter and cheese.
10%, Low	Taking chill out of fruit.

[†]STYROFOAM is a Registered Trademark of The Dow Chemical Company.

MANUAL COOKING

Add a Minute

The ADD A MINUTE control automatically starts the oven at 100% power for 1 minute, and adds 1 minute of cook time, up to 10 minutes, with each additional touch of the control. Time may be added in 1-minute increments by touching ADD A MINUTE, or by minutes and seconds using the interactive touch screen display. Cook power or cook time may be changed after cooking begins by using the “Adjust Settings” control. While settings are being adjusted, the countdown freezes, and then resumes when adjustments are made.

Micro Time/Power Cooking

The MICRO TIME/POWER control is for manual microwave-only cooking.

To Use MICRO TIME/POWER:

1. Touch MICRO TIME/POWER control pad.
2. Use number pads to enter the cook time in minutes and seconds.
If using 100% cooking power, skip Step 3.
3. Touch “Cook Power: 100%,” and then use number pad to adjust the power level, between 10% and 100%.
4. Touch “Start” on the touch screen, or START control.
The display will count down the cook time.
During the countdown, cook time and/or cooking power may be changed by touching “Adjust Settings” on the touch screen, and following the prompts.
When the cycle ends, the end-of-cycle tones will sound, followed by reminder tones.
5. Touch OFF control or open the door to stop reminder tones. The display will return to the Main Menu after OFF control is touched.

Manual Method Cooking

The Manual Method control on the Main Menu is for manual cooking by cooking method. There are 9 methods from which to choose. Some of the methods have set power levels that cannot be changed. Use the following chart as a guide.

METHOD	COOK WITH	COOKWARE	POWER/TEMP SETTINGS
Reheat	Microwaves only	Microwavable	10-100%; 100% default
Defrost	Microwaves only	Microwavable	20% only
Cook	Microwaves only	Microwavable	10-100%; 100% default
Melt	Microwaves only	Microwavable	30% only
Boil & Simmer	Microwaves only	Microwavable	Enter desired time.
Browning Pan	Microwaves only	Browning Pan	100% only
Soften	Microwaves only	Microwavable	20% only
Steam Cook	Microwaves only	Microwavable	Enter desired time.
Keep Warm	Microwaves only	Microwavable	10% only

To Use:

1. Touch “Manual Method” on the Main Menu.
2. Select a method from the chart.
3. Follow instructions on the display to program cooking time, temperature and/or cooking power.
4. Touch “Start” on the touch screen, or START control.
The display will count down the cook time.
During the countdown, cook time and some cooking powers and/or temperatures may be changed by touching “Adjust Settings” on the touch screen, and adjusting the remaining time, cooking power and/or temperature.
When the cycle ends, the end-of-cycle tones will sound, followed by reminder tones.
5. Touch OFF control or open the door to stop reminder tones. The display will return to the Main Menu after OFF control is touched.

Keep Warm

WARNING

Food Poisoning Hazard

Do not let food sit in oven more than one hour before or after cooking.

Doing so can result in food poisoning or sickness.

Hot cooked food can be kept warm in the oven. Keep Warm can be used by itself, or it can be programmed to follow a cooking cycle. See “Cooking in Stages” section.

- Cover plates of food.
- Cover foods that were covered while being cooked.
- Do not cover baked goods such as pastries, pies, turnovers, etc.

To Use:

1. Place hot cooked food on the turntable, and close the oven door.
2. Touch KEEP WARM control.
3. Adjust warm time, if desired.
4. Touch “Start” on the touch screen, or START control.

The display will count down the warm time.

During the countdown, warm time may be changed by touching “Adjust Settings” on the touch screen, and adjusting the remaining time.

When the cycle ends, the end-of-cycle tones will sound, followed by reminder tones.

5. Touch OFF control or open the door to stop reminder tones and return to the Main Menu.

Cooking in Stages (or steps)

Manual cooking may be done in stages (or steps), up to 4 stages total. The first stage may be programmed using any of the manual controls. The stages may be reviewed at any time during programming and/or cooking by touching “Review Steps” on the touch screen.

NOTE: Manual Defrost can be programmed only as the 1st stage, and is not available for subsequent stage programming.

To Cook in Stages:

1. Follow steps 1-3 in “Micro Time/Power Cooking,”
or
follow steps 1-3 in “Manual Method Cooking.”
2. Touch “Add A Step” on the touch screen.
3. Select cook method, and follow screen prompts to program the next stage.
4. Repeat steps 2 and 3 to program each additional stage.
5. Touch “Start” on the touch screen, or START control.
The display will show the cycling stage’s cook time and cooking power, and will count down each stage in turn.

During the countdown, cook time and/or cooking power for the cycling stage may be changed by touching “Adjust Settings” on the touch screen, and following the prompts.

Each stage will immediately follow the previous stage, and between cycle tones will sound when each new stage begins.

When the cycle ends, the end-of-cycle tones will sound, followed by reminder tones.
6. Touch OFF control or open the door to stop reminder tones. The display will return to the Main Menu after OFF control is touched.

PROGRAMMED COOKING

Sensor Cooking

Some automatic cycles are sensor cycles. See “Cook Method Chart.” No amounts need to be entered. A sensor in the oven detects humidity released from the food as it heats, and adjusts the cook time accordingly. The progress bar appears during sensing (see “Progress Bar” section).

Many sensor cycles require the covering of foods. Microwavable containers or steamers with loose-fitting lids are recommended. The loose-fitting lid allows enough steam to escape to be detected by the sensor. When covering foods with plastic wrap, be sure to leave a large enough vent opening to allow the steam to escape.

NOTES:

- The oven should be plugged in for at least 2 minutes.
 - The oven cavity and the exterior of the cooking container should be dry.
 - The room temperature should not exceed 95°F (35°C).
 - If the door is opened during a sensor cycle, sensing will stop and the program will be canceled.
-

Preheating

Preheating of the browning pan is programmed in many automatic cooking cycles. This preheating phase may also be skipped by touching “Skip Preheat.”

For optimal results, we recommend completing the preheating phase of each cycle in which preheating is programmed.

Doneness

Doneness for food items may be adjusted for most automatic cycles. Before starting a cycle, touch “Doneness” on the touch screen, and adjust the doneness with “+” (more done) or “-” (less done) controls. The “+” control adds to, and the “-” control subtracts from the recommended default cook time.

The more done and less done settings in most foods for which doneness may be adjusted are equal. That is, the same amount of time may be added to or subtracted from the cycle. Some of the Meat and Poultry cycles have only the more done settings.

Popcorn

Popcorn is a sensor function. The sensor determines the appropriate popping time of commercially packaged microwavable popcorn.

The sensor will determine accurate popping times for bag sizes: 3.5 oz (99 g), 3.0 oz (85 g) or 1.75 oz (50 g). For bag sizes not listed in this section, follow package directions.

- Do not place bag on cooking rack.
 - Do not use regular paper bags or glassware.
 - Pop only 1 package of popcorn at a time.
 - Follow manufacturer’s instructions when using a microwave popcorn popper.
 - Listen for popping to slow to 1 pop every 1 to 2 seconds, then stop the cycle. Do not try to pop unpopped kernels.
 - Use fresh bags of popcorn for optimal results.
 - Cooking results may vary by brand and fat content.
-

To Use Popcorn:

1. Place popcorn bag on the turntable and close the door.
 2. Touch POPCORN control.
The oven will start automatically. The display will show when the oven is sensing, and will start counting down the time when sensing has finished.
When the cycle ends, the end-of-cycle tones will sound, followed by reminder tones.
 3. Touch OFF control or open the door to stop reminder tones. The display will return to the Main Menu after OFF control is touched.
-

Using Food Type

The Food Type menu has 12 methods from which to choose.

Breakfast Food	Dairy/Dessert	Frozen Food
Liquids	Snacks	Vegetable
Bread	Casserole Leftover	Fish/Seafood
Grains (Pasta/Rice)	Meat	Poultry

This menu allows you to choose what specific food item you want to cook, and then choose how you would like to cook it, if there is more than 1 cook method available. All cook methods and foods are available through this menu.

See “Food Type Chart” in this manual, or review your Quick Reference Guide for all of the food items and programmed cycles.

See “Main Menu” section for an example of how using the Food Type menu works.

To Use: Touch “Food Type” on Main Menu, select your food category, and then follow the screen prompts to select your specific food item and cook method, and to start the cycle.

Using Cook Method

The Cook Method menu has 8 methods from which to choose.

Reheat	Defrost	Cook
Boil & Simmer	Browning Pan	Melt
Soften	Steam Cook	

This menu allows you to start with the type of cooking you want, and then choose your specific food item. All food items are available through this menu.

See each method’s respective section in this manual for method details.

See “Cook Method Chart” for all of the programmed cycles.

See “Main Menu” section for an example of how using the Cook Method menu works.

To Use: Touch “Cook Method” on Main Menu, select your desired method, and then follow the screen prompts to select your food item and to start the cycle.

Reheat

The Reheat menu has 8 main food categories, plus a shortcut to Manual Reheat (see “Manual Method Cooking” section).

Beverage	Casserole Leftover	Meal
Muffin	Pizza Leftover	Roll
Sauce	Soup	Manual Reheat

See “Cook Method Chart” for food item details, such as specific food items available, sensor functions and amounts.

To Use: Touch “Cook Method” on Main Menu, touch “Reheat,” and then follow screen prompts to make your selections, prepare your food and/or oven for reheating, and start the cycle.

Defrost

The Defrost menu has 4 main food categories, plus a shortcut to Manual Defrost (see “Manual Method Cooking” section).

Bread	Fish/Seafood	Meat
Poultry	Manual Defrost	

Defrost should not be used for food left out of the freezer for more than 20 minutes, or for frozen ready-made food.

- Food should be 0°F (-18°C) or colder at the time the cycle is started for optimal results. How foods are stored can affect results.
- Unwrap foods and remove lids (for example, from fruit juice containers) before defrosting.
- Shallow packages will defrost more quickly than thick blocks.
- Separate food pieces as soon as possible during or at the end of the cycle for more even defrosting.
- Use small pieces of aluminum foil to shield parts of food such as chicken wings, leg tips and fish tails. See “Aluminum Foil and Metal” first.

See “Cook Method Chart” for specific food items and amounts.

To Use: Touch “Cook Method” on Main Menu, touch “Defrost,” and then follow screen prompts to make your selections, and to start the cycle.

Defrost programs are set by the weight of the food item in pounds and/or ounces. If the weight is not known, touch “Weight Unknown” on the touch screen, and follow the prompts. Preparation instructions for each food item will be displayed while you are programming the cycle.

Cook

The Cook menu has 10 main food categories, plus a shortcut to manual Cook (see “Manual Method Cooking” section)

Cereal/Oatmeal	Couscous	Egg
Fish/Seafood	Frozen Food	Meat
Pasta	Poultry	Rice
Vegetable	Manual Cook	

See “Cook Method Chart” for food item details, such as sensor functions, convection functions and amounts.

To Use: Touch “Cook Method” on Main Menu, touch “Cook,” and then follow screen prompts to make your selections, prepare your food and/or oven for cooking, and start the cycle.

Boil & Simmer

The Boil & Simmer menu has 4 main food categories, plus a shortcut to Manual Boil & Simmer (see “Manual Method Cooking” section).

Couscous	Dried Pasta	Fresh Pasta
Rice	Manual Boil & Simmer	

Boil & Simmer is a sensor function.

See “Cook Method Chart” for specific food items and amounts.

- Follow recommended water and food amounts that appear on the display.
- Use a microwavable dish with a loose-fitting lid.
- Do not use plastic wrap as a cover during the Boil & Simmer cycle.
- Do not remove the lid while the dish is still in the oven, as the rush of steam will disrupt the sensor readings.

To Use: Touch “Cook Method” on Main Menu, touch “Boil & Simmer,” and then follow screen prompts to make your selections, prepare your food for simmering, and start the cycle.

Simmering Pasta

The water will need to boil before adding the pasta. Place the dish of water, covered, in the oven and begin the cycle. When the water boils, the oven will stop and prompt you to add the pasta. If manually simmering, place the covered dish of water in the oven, and set a simmer time of 1 second. The water will start to boil, the 1-second simmer time will end, and the oven will stop.

Using oven mitts, gently remove the covered dish of boiling water, add the pasta, re-cover, place the dish back in the oven and continue the cycle.

Simmering Rice

Place food and water/liquid, covered, in the oven and begin the cycle. The sensor determines when the water starts to boil, and figures the simmer time, which will begin counting down in the display.

Browning Pan

The Browning Pan menu has 7 main food categories, plus a shortcut to Manual Browning Pan (see “Manual Method Cooking” section).

Egg	Fish Steak	Frozen Food
Meat	Nuts	Poultry Breast Boneless
Sausage	Manual Browning Pan	

The Browning Pan function uses the specially designed browning pan (provided with oven) to brown, crisp, and pan-fry foods in the microwave oven. While microwaves heat food from above, they also heat the pan very quickly from below to brown and crisp the food.

Some Browning Pan cycles are programmed to preheat the empty pan for 3 minutes before cooking begins. When the preheating cycle is complete, the oven will stop and prompt you to add the food to the browning pan. The oven may prompt you to turn over the food during the cycle.

See “Cook Method Chart” for specific food items and amounts.

- Oven cavity and door will become very hot during the Browning Pan cycle. The use of oven mitts is recommended.
- The browning pan will become very hot. Use oven mitts to grasp and remove the pan from the oven. Do not place hot browning pan directly on heat-sensitive surfaces. Damage may occur.
- Use detachable handle when handling hot browning pan.
- Do not use plastic utensils on the browning pan, as it becomes very hot quickly and could melt the utensils.
- Do not use metal utensils, as they can scratch the pan.
- Do not use the browning pan in any other microwave oven or in a standard thermal oven.
- For best results, coat the browning pan lightly with cooking oil to make removing food and cleaning the pan easier.

To Use: Touch “Cook Method” on Main Menu, touch “Browning Pan,” and then follow screen prompts to make your selections, prepare the food and/or browning pan for cooking, and start the cycle.

Melt

The Melt menu has 5 main food categories, plus a shortcut to Manual Melt (see “Manual Method Cooking” section).

Butter/Margarine	Caramel	Cheese
Chocolate	Marshmallow	Manual Melt

See “Cook Method Chart” for specific food items and amounts.

To Use: Touch “Cook Method” on Main Menu, touch “Melt,” and then follow screen prompts to make your selections, prepare your food and/or oven for cooking, and start the cycle.

Soften

The Soften menu has 6 main food categories, plus a shortcut to Manual Soften (see “Manual Method Cooking” section).

Brown Sugar	Butter/Margarine	Caramel Dip
Cream Cheese	Frozen Juice	Ice Cream
Manual Soften		

See “Cook Method Chart” for specific food items and amounts.

To Use: Touch “Cook Method” on Main Menu, touch “More Choices,” and then “Soften.” Follow screen prompts to make your selections, prepare your food and/or oven for cooking, and start the cycle.

Steam Cook

The Steam Cook menu has 4 main food categories, plus a shortcut to Manual Steam Cook (see “Manual Method Cooking” section).

Fish Fillet	Fresh Vegetable	Frozen Vegetable
Shrimp	Manual Steam Cook	

Steam Cook is a sensor function.

See “Cook Method Chart” for specific food items and amounts.

- Use a microwavable steamer with a loose-fitting lid. Place 1¼ cups (295 mL) water in the steamer base, place food in the steamer insert, place the insert in the base and cover with its lid.
- Do not remove the lid while the steamer is inside the oven, as the rush of steam will disrupt the sensor readings.
- The steamer will become hot. Always use oven mitts or pot holders when handling.
- Do not overfill. One-half full is recommended.
- Follow directions on the display.

To Use: Touch “Cook Method” on Main Menu, touch “More Choices,” and then “Steam Cook.” Follow screen prompts to make your selections, prepare the food for steaming, and start the cycle.

Most Used Menu

The Most Used menu displays the 6 most used automatic cooking programs. This provides you with your own customized menu, which is easily accessible from the Main Menu.

The programs are shown in order of frequency of use. The food type is shown first on the selection pad, followed on the next line by the cook method. Following is the default Most Used menu screen:

MOST USED		
Beverage Reheat	Butter/Marg Melt	Butter/Marg Soften
Brown Sugar Soften	Crn Cheese Soften	Lftover Pizza Reheat
< Back	Auto Update	

To Update Most Used Menu: On the Most Used screen, touch “Auto Update.” The oven shows the 6 programs used most frequently since the last time the menu was updated.

Food Type Chart

Use this chart as a reference for menu items available in the “Food Type” menu.

BREAKFAST FOOD

Bacon

Cook or Browning Pan

Cereal Instant

Cook

Egg

Fried

Cook or Browning Pan

Omelet

Cook or Browning Pan

Poached

Cook

Scrambled

Cook

French Toast

Cook or Browning Pan

Grits

Quick

Cook

Regular

Cook

Hash Brown

Cook or Browning Pan

Hot Wheat

Cook

Muffin

Fresh

Reheat

Frozen

Defrost or Reheat

Oatmeal

Instant

Cook

Regular

Cook

Sausage

Cook or Browning Pan

DAIRY/DESSERT

Brown Sugar

Soften

Butter/Margarine

Melt or Soften

Caramel

Melt

Caramel Dip

Soften

Cheese

Melt

Chocolate

Melt

Cream Cheese

Soften

Ice Cream

Soften

Marshmallow

Melt

Nuts

Browning Pan

FROZEN FOOD

Frozen Entrée

Regular (8-20 oz [227-567 g])

Cook

Large (40 oz [1.1 kg])

Cook

Family Size (60 oz [1.7 kg])

Cook

Fish

Fillet, Breaded

Cook or Browning Pan

Fillet, Non-Breaded

Defrost, Cook or Browning Pan

Fish Stick

Cook or Browning Pan

French Toast

Cook or Browning Pan

Hash Brown

Cook or Browning Pan

Pizza

5" Kids Pizza

Cook

Pizza Roll

Cook or Browning Pan

Thin Crust Pizza

Cook or Browning Pan

Poultry

Chicken Nuggets

Cook or Browning Pan

Chicken Tenders

Cook or Browning Pan

Soup

Reheat

Vegetable

Cook or Steam Cook

LIQUIDS

Beverage

Reheat

Frozen Juice

Soften

Soup, Frozen

Reheat

Soup, Thick

Reheat

Soup, Thin

Reheat

Sauce

Thick

Reheat

Thin

Reheat

SNACKS

Burrito

Cook

Cheese Sticks

Cook or Browning Pan

Instant Macaroni & Cheese

Cook

Kids Pizza 5"

Cook

Marshmallow

Melt

Pizza, Leftover

Reheat

Pizza Roll

Cook or Browning Pan

Potato Nuggets

Browning Pan

Snack Pocket

Cook

VEGETABLE

Canned Vegetable

Cook

Fresh Vegetable

Asparagus

Cook or Steam Cook

Broccoli

Cook or Steam Cook

Carrots

Cook or Steam Cook

Cauliflower

Cook or Steam Cook

Corn on the Cob

Cook or Steam Cook

Green Beans

Cook or Steam Cook

Mushroom

Cook

Potato Baked/Sweet

Cook

Potato New Red

Steam Cook

Spinach

Cook or Steam Cook

Summer Squash/Zucchini

Cook or Steam Cook

Frozen Vegetable

Cook or Steam Cook

BREAD

Bagel

Small

Defrost

Medium

Defrost

Large

Defrost

French Toast

Cook or Browning Pan

Muffin

Fresh

Reheat

Frozen

Reheat or Defrost

Roll

Fresh/Leftover

Reheat

Frozen

Reheat or Defrost

CASSEROLE

Casserole, Leftover

Reheat

FISH/SEAFOOD

Fish Fillet

Fresh

Cook or Steam Cook

Frozen, Breaded

Cook or Browning Pan

Frozen, Non-Breaded

Cook, Defrost or Steam Cook

Fish Steak

Cook, Defrost or Browning Pan

Fish Stick, Frozen

Cook or Browning Pan

Scallops

Defrost

Shrimp

Defrost or Steam Cook

GRAINS: PASTA/RICE

Canned Pasta

Cook

Couscous

Cook or Boil & Simmer

Grits

Quick

Cook

Regular

Cook

Instant Macaroni & Cheese

Cook

Pasta

Dried Pasta

Fettuccine

Cook or Boil & Simmer

Macaroni

Cook or Boil & Simmer

Penne

Cook or Boil & Simmer

Rotini

Cook or Boil & Simmer

Spaghetti

Cook or Boil & Simmer

Fresh Pasta

Linguine

Cook or Boil & Simmer

Ravioli

Cook or Boil & Simmer

Tortellini

Cook or Boil & Simmer

Rice

Brown Rice

Instant

Cook or Boil & Simmer

Long Grain

Cook or Boil & Simmer

White Rice

Instant

Cook or Boil & Simmer

Long Grain

Cook or Boil & Simmer

Short Grain

Cook or Boil & Simmer

MEAT

Beef

Ground Beef

Defrost or Cook

Hamburger Patty

Cook or Browning Pan

Steak

Defrost

Hot Dog

Cook

Meatballs

Cook or Browning Pan

Pork

Bacon

Cook or Browning Pan

Ham Slice

Cook or Browning Pan

Ham Steak

Cook or Browning Pan

Pork Chops

Defrost

Sausage

Cook or Browning Pan

POULTRY

Chicken Nuggets

Cook or Browning Pan

Chicken Pieces, Boneless

Defrost or Cook

Chicken Pieces, Bone-In

Defrost or Cook

Chicken Tenders

Cook or Browning Pan

Ground Poultry

Defrost or Cook

Poultry Breast, Boneless Pan Brown

Cook or Browning Pan

Poultry Breast, Boneless Poached

Cook

Cook Method Chart

Use this chart as a reference for menu items and amounts available in the "Cook Method" menu.

REHEAT

Beverage

1 or 2 cups (250-500 mL)

Casserole, Leftover

1-4 cups (250 mL-1 L)

Meal (dinner plate)

1 meal (sensor)

2 meals

Muffin

Fresh: 1-6 muffins

Frozen: 1-6 muffins

Pizza Leftover

1-3 slices

Roll

Fresh: 1-6 rolls

Frozen: 1-6 rolls

Sauce

Thick: senses 1-4 cups (250 mL-1 L)

Thin: senses 1-4 cups (250 mL-1 L)

Soup

Frozen: 1-4 cups (250 mL-1 L)

Thick: senses 1-4 cups (250 mL-1 L)

Thin: senses 1-4 cups (250 mL-1 L)

Manual Reheat

DEFROST

Bread

0.1-2.0 lbs (45-900 g)

Weight Unknown

Bagel

small: 2-8 bagels

medium: 1-6 bagels

large: 1-6 bagels

Muffin

small: 4, 6, 8, 10, 12, 14 or 16 muffins

medium: 1-6 muffins

large: 1-6 muffins

Roll

small: 1-6 rolls

medium: 1-6 rolls

large: 1-6 rolls

Fish/Seafood

0.1-4.5 lbs (45 g-2.0 kg)

Weight Unknown

Fillet: 1-6 pieces

Shrimp: 1-4 cups (250 mL-1 L)

Scallops: 1-4 cups (250 mL-1 L)

Steak: 1-4 pieces

Meat

0.1-6.5 lbs (45 g-2.9 kg)

Weight Unknown

Chops

small: 1-6 pieces

medium: 1-6 pieces

large: 1-4 pieces

Ground: 1, 2, 3 or 4 cups (250, 500, 750 mL or 1 L)

Steak

small: 1-6 pieces

medium: 1-4 pieces

large: 1 or 2 pieces

Poultry

0.1-6.5 lbs (45 g-2.9 kg)

Weight Unknown

Breast: 1-6 pieces

Ground: 1, 2, 3 or 4 cups (250, 500, 750 mL or 1 L)

Pieces

small: 1-6 pieces

medium: 1-4 pieces

large: 1-4 pieces

COOK

Cereal/Oatmeal

- Grits
 - Quick: senses 1-4 servings
 - Regular: senses 1-4 servings
- Hot Wheat: 1-4 servings
- Instant Cereal: 1-4 servings
- Oatmeal
 - Instant: 1-4 servings
 - Regular: 1-4 servings

Couscous

- senses 1-4 servings

Egg

- Fried: 1-4 eggs
- Omelet: 2-4 eggs
- Poached: 1-4 eggs
- Scrambled: 1-4 eggs

Fish/Seafood

- Fish Fillet
 - Fresh: senses 0.5-1.5 lbs (227-680 g)
 - Frozen, Breaded: 1-4 servings
 - Frozen, Non-breaded: 1-6 pieces
- Fish Steak: 1 or 2 steaks
- Fish Stick, Frozen: 1-4 servings (6-18 sticks)

Frozen Food

- Burrito: 1 or 2 burritos
- Cheese Sticks: 1-4 servings
- Fish/Seafood
 - Fillet, Breaded: 1-4 servings
 - Fillet, Non-Breaded: 1-4 servings
 - Fish Stick: 1-4 servings (6-18 pieces)
- French Toast: 1-4 pieces
- Frozen Entrée
 - Regular: senses 8-20 oz (227-567 g)
 - Large: 40 oz (1.1 kg)
 - Family: 60 oz (1.7 kg)
- Frozen Pizza
 - 5" Kids Pizza
 - Pizza Roll: 1-4 servings
 - Thin Crust: 6" - 12" (15.2-30.5 cm)
- Frozen Vegetable: senses 2-6 cups (500 mL-1.5 L)
- Hash Brown: 1-4 patties
- Snack Pocket: 1 or 2 servings

Meat

- Bacon: 2-4 slices
- Ground Beef: 0.5, 1.0, 1.5 or 2.0 lbs (227, 454, 680 or 900 g)
- Ham Slice: 1-4 slices
- Ham Steak: 4-8 oz (113-227 g)
- Hamburger Patty: 1-4 patties
- Hot Dog: 1-4 hot dogs
- Meatballs: 0.5 or 1.0 lb (227 or 454 g)
- Sausage: 2-10 links

Pasta

- Canned Pasta: senses 1-4 servings
- Dried Pasta
 - Fettuccine: senses 2-8 oz (57-227 g)
 - Macaroni: senses 0.5-2.0 cups (125-500 mL)
 - Penne: senses 0.5-2.0 cups (125-500 mL)
 - Rotini: senses 0.5-2.0 cups (125-500 mL)
 - Spaghetti: senses 2-8 oz (57-227 g)
- Fresh Pasta
 - Linguine: senses 9 or 18 oz (255 or 510 g)
 - Ravioli: senses 9 or 18 oz (255 or 510 g)
 - Tortellini: senses 9 or 18 oz (255 or 510 g)
- Instant Macaroni & Cheese
 - 1 or 2 servings

Poultry

- Chicken Nuggets: 1-4 servings (4-16 pieces)
- Chicken Pieces
 - Bone-In: 0.5-3.5 lbs (227 g-1.5 kg)
 - Boneless: 0.2-1.5 lbs (90-680 g)
- Chicken Tenders: 1-4 servings
- Ground Poultry: 0.5, 1.0, 1.5 or 2.0 lbs (227, 454, 680 or 907 g)
- Poultry Breast Boneless
 - Pan Brown: 1-3 pieces
 - Poached: 0.2-1.5 lbs (90-680 g)

Rice

- Brown Rice
 - Instant: senses 0.5-2.0 cups (125-500 mL)
 - Long Grain: senses 0.5-2.0 cups (125-500 mL)
- White Rice
 - Instant: senses 0.5-2.0 cups (125-500 mL)
 - Long Grain: senses 0.5-2.0 cups (125-500 mL)
 - Short Grain: senses 0.5-2.0 cups (125-500 mL)

Vegetable

- Canned Vegetable: 8-32 oz (237-946 mL)
- Fresh Vegetable
 - Asparagus: senses 8-16 oz (227-454 g)
 - Broccoli: senses 1-6 cups (250 mL-1.5 L)
 - Carrots: senses 1-6 cups (250 mL-1.5 L)
 - Cauliflower: senses 1-6 cups (250 mL-1.5 L)
 - Corn on the Cob: senses 1-4 ears
 - Green Beans: senses 1-6 cups (250 mL-1.5 L)
 - Mushroom: senses 1-6 cups (250 mL-1.5 L)
 - Potato, Baked/Sweet: senses 1-4 potatoes
 - Spinach: senses 2-6 cups (500 mL-1.5 L)
 - Summer Squash/Zucchini: senses 1-6 cups (250 mL-1.5 L)
- Frozen Vegetable: senses 2-6 cups (500 mL-1.5 L)

Manual Cook

BOIL & SIMMER

Couscous

senses 1-4 servings

Dried Pasta

Fettuccine: senses 2-8 oz (57-227 g)

Macaroni: senses 0.5-2.0 cups (125-500 mL)

Penne: senses 0.5-2.0 cups (125-500 mL)

Rotini: senses 0.5-2.0 cups (125-500 mL)

Spaghetti: senses 2-8 oz (57-227 g)

Fresh Pasta

Linguine: senses 9 or 18 oz (255 or 510 g)

Ravioli: senses 9 or 18 oz (255 or 510 g)

Tortellini: senses 9 or 18 oz (255 or 510 g)

Rice

Brown Rice

Instant: senses 0.5-2.0 cups (125-500 mL)

Long Grain: senses 0.5-2.0 cups (125-500 mL)

White Rice

Instant: senses 0.5-2.0 cups (125-500 mL)

Long Grain: senses 0.5-2.0 cups (125-500 mL)

Short Grain: senses 0.5-2.0 cups (125-500 mL)

Manual Boil & Simmer

BROWNING PAN

Egg

Fried: 1-4 eggs

Omelet: 2-4 eggs

Fish Steak

0.5-1.0 lb (227-454 g)

Frozen Food

Cheese Sticks: 1-4 servings

Chicken Nuggets: 1-4 servings (4-16 pieces)

Chicken Tenders: 1-4 servings

Fish

Fillet Frozen, Breaded: 1-4 servings

Fish Stick Frozen: 1-4 servings (6-18 pieces)

French Toast: 1-4 pieces

Hash Brown: 1-4 patties

Pizza Roll: 1-4 servings

Pizza Thin Crust: 6"-12" (15.2-30.5 cm)

Potato Nuggets: 1-4 servings

Sausage: 2-10 links

Meat

Bacon: 2-4 slices

Ham Slice: 1-4 slices

Ham Steak: 4-8 oz (113-227 g)

Hamburger Patty: 1-4 patties, 0.3 lb (136 g) each

Meatballs: 0.5-1.0 lbs (227-454 g)

Nuts

0.5, 1.0, 1.5 or 2 cups (125, 250, 375 or 500 mL)

Poultry Breast, Boneless

1-3 pieces, 0.4 lb (113 g) each

Sausage

2-10 links

Manual Browning Pan

MELT

Butter/Margarine

0.5, 1.0, 1.5 or 2 sticks or 1-8 tbs (15-120 mL)

Caramel

7 or 14 oz (199 or 397 g)

Cheese

8 or 16 oz (227 or 454 g)

Chocolate

1-12 oz (28-340 g) or 0.5, 1.0, 1.5 or 2.0 cups (125, 250, 375 or 500 mL)

Marshmallow

5 or 10 oz (142-283 g)

Manual Melt

SOFTEN

Brown Sugar

0.5, 1.0, 1.5 or 2.0 cups (125, 250, 375 or 500 mL)

Butter/Margarine

0.5, 1.0, 1.5 or 2 sticks or 1-8 tbs (15-120 mL)

Caramel Dip

18 oz (510 g)

Cream Cheese

3 or 8 oz (85 or 227 g)

Frozen Juice

6, 12 or 16 oz (170, 340 or 454 g)

Ice Cream

16, 32 or 64 oz (473, 946 mL or 1.9 L)

Manual Soften

STEAM COOK

Fish Fillet

senses 0.5-1.5 lb (227-680 g)

Fresh Vegetable

Asparagus: senses 8-16 oz (227-454 g)

Broccoli: senses 2-6 cups (500 mL-1.5 L)

Carrots: senses 2-6 cups (500 mL-1.5 L)

Cauliflower: senses 2-6 cups (500 mL-1.5 L)

Corn on the Cob: senses 1-4 ears

Green Beans: senses 2-6 cups (500 mL-1.5 L)

Red Potato, New: senses 2-6 cups (500 mL-1.5 L)

Spinach: senses 4-8 cups (1-2 L)

Summer Squash/Zucchini: senses 2-6 cups (500 mL-1.5 L)

Frozen Vegetable

senses 2-6 cups (500 mL-1.5 L)

Shrimp

senses 5-8 oz (142-227 g)

Manual Steam Cook

OVEN CARE

General Cleaning

IMPORTANT: Before cleaning, make sure all controls are off and the microwave oven is cool. Always follow label instructions on cleaning products.

Soap, water and a soft cloth or sponge are suggested unless otherwise noted.

GREASE FILTERS

Do not use ammonia or corrosive cleaning agents such as lye-based oven cleaners.

- Hot water and mild detergent:

Soak filters, then scrub and swish to remove embedded dirt and grease. Rinse well and shake to dry.

- Dishwasher:

Wash separately, not with dirty dishes, because food can be trapped in the filters.

NOTE: Some discoloration of the filters may occur after cleaning them in the dishwasher. This is normal, and will not affect the performance of the grease filters.

OVEN CAVITY

The gray finish inside the oven cavity is a durable, nonstick coating that makes soils easier to remove.

Do not use metal or sharp utensils or scrapers, soap-filled scouring pads, abrasive cleaners, steel-wool pads, gritty washcloths or some recycled paper towels. Damage may occur. If damage does occur, special touch up paint may be applied. See “Assistance or Service” to order.

The area where the oven door and frame touch when closed should be kept clean.

Average soil

- Mild, nonabrasive soaps and detergents:

Rinse with clean water and dry with soft, lint-free cloth.

Heavy soil

- Mild, nonabrasive soaps and detergents:

Heat 1 cup (250 mL) of water for 2 to 5 minutes in oven. Steam will soften soil. Rinse with clean water and dry with soft, lint-free cloth.

Odors

- Lemon juice or vinegar:

Heat 1 cup (250 mL) of water with 1 tbs (15 mL) of either lemon juice or vinegar for 2 to 5 minutes in oven.

Microwave Inlet Cover

The microwave inlet cover (see “Parts and Features”) should be kept clean to avoid arcing and oven damage.

- Wipe with wet cloth.

CONTROL PANEL/INTERACTIVE TOUCH DISPLAY

Activate the Control Lock to avoid touch screen activation during cleaning. See “Control Lock” section.

Do not use abrasive cleaners, steel-wool pads or gritty washcloths. Damage may occur.

Use gentle pressure when wiping the touch screen.

- Glass cleaner and soft cloth:

Apply glass cleaner to soft cloth, not directly on panel.

- Mild soap, water and soft washcloth

OVEN DOOR AND EXTERIOR

The area where the oven door and frame touch when closed should be kept clean.

- Mild, nonabrasive soaps and detergents:

Rinse with clean water and dry with soft, lint-free cloth.

- Glass cleaner and paper towels or nonabrasive plastic scrubbing pad:

Apply glass cleaner to towel, not directly to surface.

Stainless Steel (on some models)

Do not use soap-filled scouring pads, abrasive cleaners, steel-wool pads, gritty washcloths or some paper towels. Damage may occur.

Rub in direction of grain to avoid damaging.

- KitchenAid® Stainless Steel Cleaner & Polish (not included)
KitchenAid® Stainless Steel Wipes (not included):

See “Assistance or Service” section to order.

- Liquid detergent or all-purpose cleaner:

Rinse with clean water and dry with soft, lint-free cloth.

- Vinegar for hard water spots

TURNTABLE

Replace turntable immediately after cleaning. Do not operate the microwave oven without the turntable in place.

- Mild cleanser and scouring pad

- Dishwasher

BROWNING PAN

Do not use abrasive cleansers or scrubbers.

- Mild cleanser, water and washcloth
- Dishwasher

COOKING RACK

Dishwasher cleaning is not recommended. Do not use abrasive cleansers or scrubbers.

- Mild cleanser, water and washcloth

RACK SUPPORTS

Clean often to avoid soil buildup. Soil buildup may lead to arcing and cause damage to the oven.

Do not attempt to remove supports from cavity walls.

Do not use soap-filled scouring pads, abrasive cleaners, steel-wool pads, gritty washcloths or some recycled paper towels.

- Mild, nonabrasive soap or detergent and washcloth, toothbrush or cotton swab:

Rinse with clean water and dry with soft, lint-free cloth.

Replacing Filters

The grease filters should be removed and cleaned at least once a month. The charcoal filters cannot be washed and should be replaced every 6 to 12 months. Do not operate the oven without the filters in place. See "Replacement Parts" section in "Assistance or Service" to reorder filters. See "General Cleaning" for cleaning instructions.

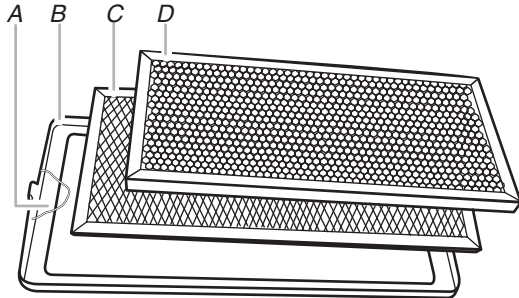

A. Retaining spring
B. Filter frame
C. Grease filter
D. Charcoal filter

To Remove/Replace:

1. Squeeze the small tab on the outer edge of the filter frame inward, and pull down until the frame and filters drop out.

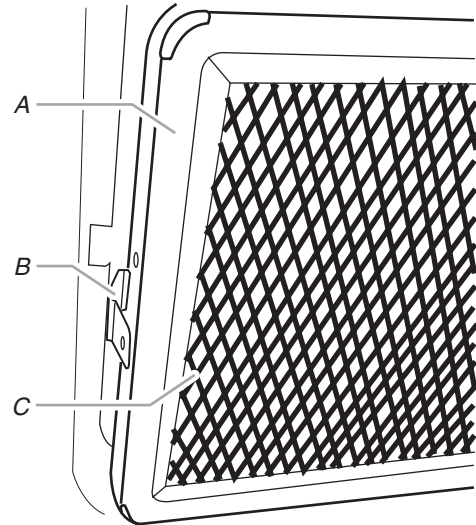

A. Filter frame
B. Small tab
C. Grease filter

2. Replace the filters by inserting the wide tab of the filter frame into the inner portion of the filter housing, then swinging the outside of the frame up until it fits into place.

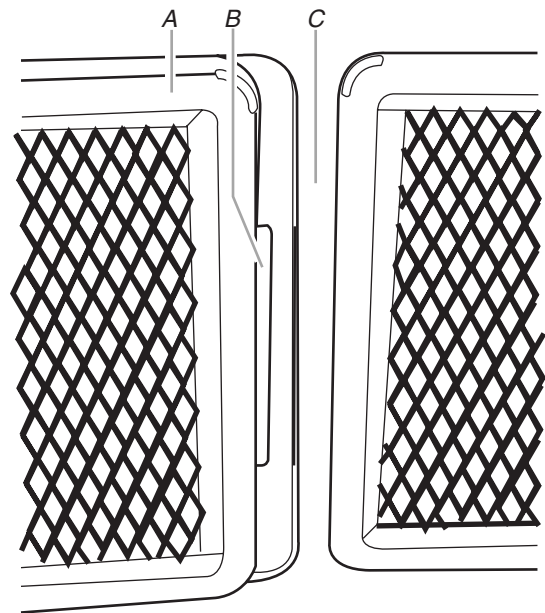

A. Filter frame
B. Wide tab
C. Microwave oven bottom

Replacing Cooktop Light

The cooktop light consists of two 10W low-voltage halogen capsule bulbs. See "Assistance or Service" section to reorder. You will need a TORX®† T10 screwdriver to remove the bulb cover mounting screw.

To Replace:

1. Unplug oven or disconnect power.
2. Remove bulb cover mounting screw, and gently open cover.

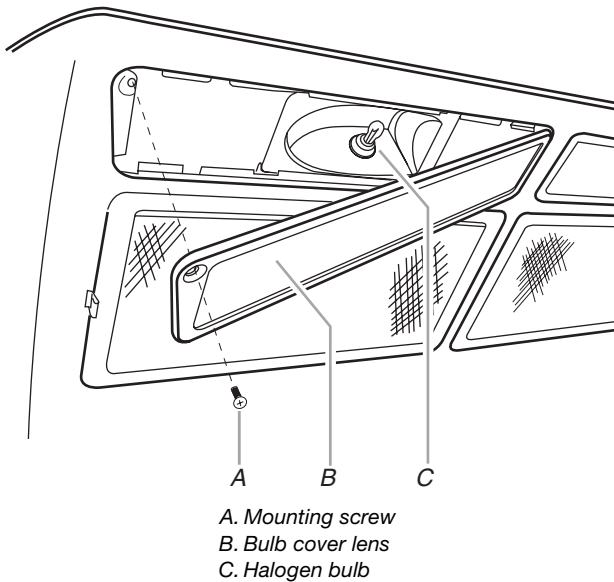

3. Remove the burned-out bulb.
4. Replace bulb, using a tissue or wearing clean cotton gloves to handle the bulb. Do not touch bulb with bare fingers.
5. Close bulb cover and replace mounting screw.
6. Plug in oven or reconnect power.

Replacing Oven Light

The oven light is a 10W low-voltage halogen capsule bulb. It will automatically come on when the door is opened and when the oven is operating. See "Assistance or Service" section to reorder. You will need a TORX®† T10 screwdriver to remove the bulb cover.

To Replace:

1. Unplug oven or disconnect power.
2. Gently pull vent screen rings and lift the screen off the exhaust vent at the top of the oven.

If using recirculating exhaust venting, skip Step 3.

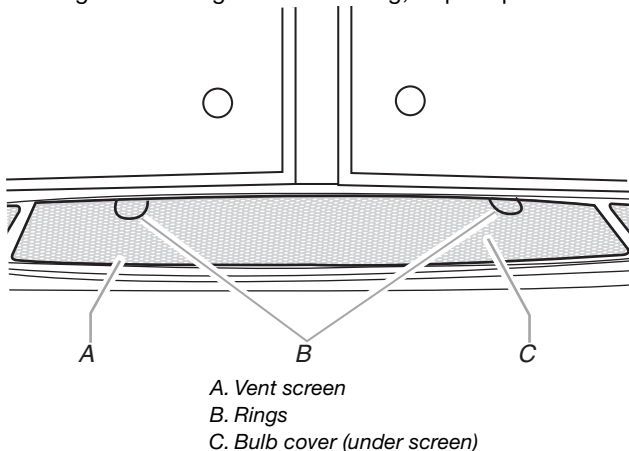

†TORX is a registered trademark of Textron Innovations Inc.

3. For wall or roof venting, remove the vent deflector by removing the mounting screws (1 from each end), and lifting out the vent deflector.

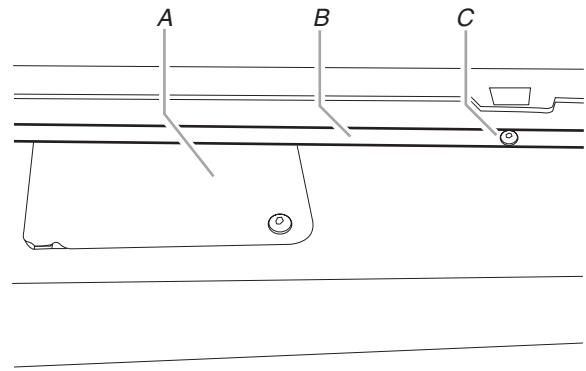

A. Bulb cover
B. Vent deflector
C. Vent deflector mounting screws (2)

4. Remove the bulb cover mounting screw, then lift cover.

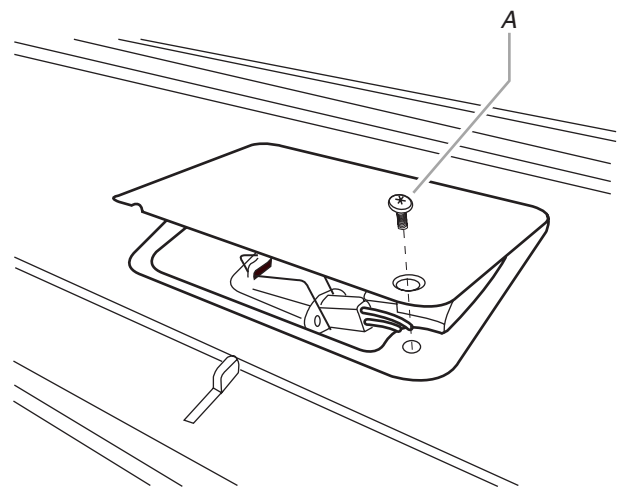

A. Bulb cover mounting screw

5. Remove the burned-out bulb by squeezing the wire clip together, pulling to the right and lifting.

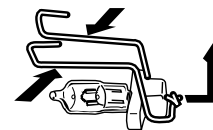

6. Replace bulb, using tissue or wearing clean cotton gloves to handle bulb. Do not touch bulb with bare fingers.
7. Close bulb cover, and fasten with screw.
If using recirculating exhaust venting, skip Step 8.
8. For wall or roof venting, replace the vent deflector removed in Step 3.
9. Replace vent screen.
10. Plug in oven or reconnect power.

TROUBLESHOOTING

Try the solutions suggested here first in order to avoid the cost of an unnecessary service call.

Nothing will operate

- **Has a household fuse blown, or has the circuit breaker tripped?**
Replace the fuse or reset the circuit breaker. If the problem continues, call an electrician.
- **Is the appliance wired properly?**
See Installation Instructions provided with your microwave oven.

Oven will not operate

- **Is the door completely closed?**
Firmly close door.
- **Is a spacer (on some models) attached to the inside of the door?**
Remove spacer, then firmly close door.
- **Is the electronic oven control set correctly?**
See “Oven Control” section.
- **Is the Control Lock set?**
See “Control Lock” section.
- **Is the Learning Mode activated?**
See “Learning Mode” section.
- **Is the magnetron working properly?**
Try to heat 1 cup (250 mL) of cold water for 2 minutes at 100% cooking power. If water does not heat, call for service. See “Assistance or Service” section.
- **Does the display show a message about opening the door?**
The door has been closed for an extended period of time (about 5 minutes) after placing food and before starting the oven. Open and close the door, then start the cycle.

Oven door looks wavy

- This is normal and will not affect performance.

Turntable will not operate

- **Is the turntable properly in place?**
Make sure turntable is correct side up and is sitting securely on the turntable support.
- **Is the turntable support operating properly?**
Remove turntable. Remove and clean turntable support and rollers. Replace turntable support. Replace turntable. Place 1 cup (250 mL) of water on turntable, then restart oven. If it still is not working, call for service. See “Assistance or Service” section. Do not operate the oven without turntable and turntable support working properly.

Turntable alternates rotation directions

- This is normal and depends on motor rotation at the beginning of the cycle.

Display shows time countdown, but is not operating

- **Is the Timer in use?**
See “Timer” section.
- **Is the Learning Mode in use?**
See “Learning Mode” section.

Steam is coming from the vent screen

- Some steam is normal.

Fan running slower than usual

- **Has the oven been stored in a cold area?**
The fan will run slower until the oven warms up to normal room temperature.

Fan running during cooktop usage

- This is normal. The oven’s cooling fan, which is separate from the vent fan, automatically comes on during oven operation to cool the oven. Both the vent fan and the cooling fan may also automatically come on and cycle on and off to cool the oven’s controls while the cooktop below is being used.

Cooking times seem too long

- **Is the cooking power set properly?**
See “Microwave Cooking Power” section.
- **Are large amounts of food being heated?**
Larger amounts of food need longer cooking times.
- **Is the incoming voltage less than specified in “Microwave Hood Combination Safety?”**
Have a qualified electrician check the electrical system in the home.

Radio, TV or cordless phone interference

- **Is the oven plugged into the same outlet?**
Try a different outlet.
- **Is the radio or TV receiver near the oven?**
Move the receiver away from the oven, or adjust the radio or TV antenna.
- **Are the oven door and sealing surfaces clean?**
Make sure these areas are clean.
- **Is the cordless phone frequency 2.4 GHz?**
Some 2.4 GHz-based cordless phones and home wireless networks may experience static or noise while the oven is on. Use a corded phone or a different frequency cordless phone, or avoid using these items during oven operation.

ASSISTANCE OR SERVICE

Before calling for assistance or service, please check "Troubleshooting." It may save you the cost of a service call. If you still need help, follow the instructions below.

When calling, please know the purchase date and the complete model and serial number of your appliance. This information will help us to better respond to your request.

If you need replacement parts

If you need to order replacement parts, we recommend that you use only factory specified parts. These factory specified parts will fit right and work right because they are made with the same precision used to build every new KITCHENAID® appliance.

To locate factory specified parts in your area, call us or your nearest KitchenAid designated service center.

In the U.S.A.

Call the KitchenAid Customer eXperience Center toll free: **1-800-422-1230.**

Our consultants provide assistance with:

- Features and specifications on our full line of appliances.
- Installation information.
- Use and maintenance procedures.
- Accessory and repair parts sales.
- Specialized customer assistance (Spanish speaking, hearing impaired, limited vision, etc.).
- Referrals to local dealers, repair parts distributors and service companies. KitchenAid designated service technicians are trained to fulfill the product warranty and provide after-warranty service, anywhere in the United States.

To locate the KitchenAid designated service company in your area, you can also look in your telephone directory Yellow Pages.

For further assistance

If you need further assistance, you can write to KitchenAid with any questions or concerns at:

KitchenAid Brand Home Appliances
Customer eXperience Center
553 Benson Road
Benton Harbor, MI 49022-2692

Please include a daytime phone number in your correspondence.

Replacement Parts

Turntable Part Number 8205992	Browning Pan Part Number 8205996
Turntable Support and Rollers Part Number 8206222	Browning Pan Handle Part Number 8204652
Turntable Hub Part Number 8205994	Grease Filters (2) Part Number 8205997
Cooking Rack (rectangular) Part Number 8206117	Charcoal Filters (2) Part Number 8205998
Cooking Rack Spacer Part Number 8206116	Cooktop and Microwave Oven Light Part Number 8204670
Cooking Rack Hook Part Number 8206118	

Cleaning and Maintenance Supplies

Heavy Duty Degreaser Part Number 31552	KITCHENAID® Stainless Steel Cleaner & Polish Part Number 4396920
All-Purpose Appliance Cleaner Part Number 31662	KITCHENAID® Stainless Steel Wipes Part Number 8212510
Cavity Touch Up Paint Part Number 8204955	

KITCHENAID® BUILT-IN OVEN & MICROWAVE WARRANTY

ONE YEAR LIMITED WARRANTY

For one year from the date of purchase, when this major appliance is operated and maintained according to instructions attached to or furnished with the product, KitchenAid or KitchenAid Canada (hereafter "KitchenAid") will pay for factory specified parts and repair labor to correct defects in materials or workmanship. Service must be provided by a KitchenAid designated service company.

SECOND THROUGH FIFTH YEAR LIMITED WARRANTY ON CERTAIN COMPONENT PARTS

In the second through fifth years from the date of purchase, when this appliance is operated and maintained according to instructions attached to or furnished with the product, KitchenAid or KitchenAid Canada will pay for factory specified parts for the following components if defective in materials or workmanship:

- Electric element
- Solid state touch control system parts

SECOND THROUGH TENTH YEAR LIMITED WARRANTY

On microwave ovens only, in the second through tenth years from date of purchase, when this major appliance is operated and maintained according to instructions attached to or furnished with the product, KitchenAid will pay for factory specified parts for the stainless steel oven cavity/inner door if the part rusts through due to defects in materials or workmanship.

ITEMS KITCHENAID WILL NOT PAY FOR

1. Service calls to correct the installation of your major appliance, to instruct you how to use your major appliance, to replace or repair house fuses or to correct house wiring or plumbing.
2. Service calls to repair or replace appliance light bulbs, air filters or water filters. Those consumable parts are excluded from warranty coverage.
3. Repairs when your major appliance is used for other than normal, single-family household use.
4. Damage resulting from accident, alteration, misuse, abuse, fire, flood, acts of God, improper installation, installation not in accordance with electrical or plumbing codes, or use of products not approved by KitchenAid.
5. Replacement parts or repair labor costs for units operated outside the United States or Canada.
6. Pickup and delivery. This major appliance is designed to be repaired in the home.
7. Repairs to parts or systems resulting from unauthorized modifications made to the appliance.
8. Expenses for travel and transportation for product service in remote locations.
9. The removal and reinstallation of your appliance if it is installed in an inaccessible location or is not installed in accordance with published installation instructions.

DISCLAIMER OF IMPLIED WARRANTIES; LIMITATION OF REMEDIES

CUSTOMER'S SOLE AND EXCLUSIVE REMEDY UNDER THIS LIMITED WARRANTY SHALL BE PRODUCT REPAIR AS PROVIDED HEREIN. IMPLIED WARRANTIES, INCLUDING WARRANTIES OF MERCHANTABILITY OR FITNESS FOR A PARTICULAR PURPOSE, ARE LIMITED TO ONE YEAR OR THE SHORTEST PERIOD ALLOWED BY LAW. KITCHENAID SHALL NOT BE LIABLE FOR INCIDENTAL OR CONSEQUENTIAL DAMAGES. SOME STATES AND PROVINCES DO NOT ALLOW THE EXCLUSION OR LIMITATION OF INCIDENTAL OR CONSEQUENTIAL DAMAGES, OR LIMITATIONS ON THE DURATION OF IMPLIED WARRANTIES OF MERCHANTABILITY OR FITNESS, SO THESE EXCLUSIONS OR LIMITATIONS MAY NOT APPLY TO YOU. THIS WARRANTY GIVES YOU SPECIFIC LEGAL RIGHTS AND YOU MAY ALSO HAVE OTHER RIGHTS, WHICH VARY FROM STATE TO STATE OR PROVINCE TO PROVINCE.

Outside the 50 United States and Canada, this warranty does not apply. Contact your authorized KitchenAid dealer to determine if another warranty applies.

If you need service, first see the "Troubleshooting" section of the Use & Care Guide. After checking "Troubleshooting," additional help can be found by checking the "Assistance or Service" section or by calling KitchenAid. In the U.S.A., call **1-800-422-1230**. In Canada, call **1-800-807-6777**. 9/05

Keep this book and your sales slip together for future reference. You must provide proof of purchase or installation date for in-warranty service.

Write down the following information about your major appliance to better help you obtain assistance or service if you ever need it. You will need to know your complete model number and serial number. You can find this information on the model and serial number label located on the product.

Dealer name _____
Address _____
Phone number _____
Model number _____
Serial number _____
Purchase date _____