



StrengthTrainer®

ST-FBR

FLAT BENCH W/ RACK Owner's Manual

Questions?

Call Us Toll Free
Keys Fitness Helpline
1-888-340-0482

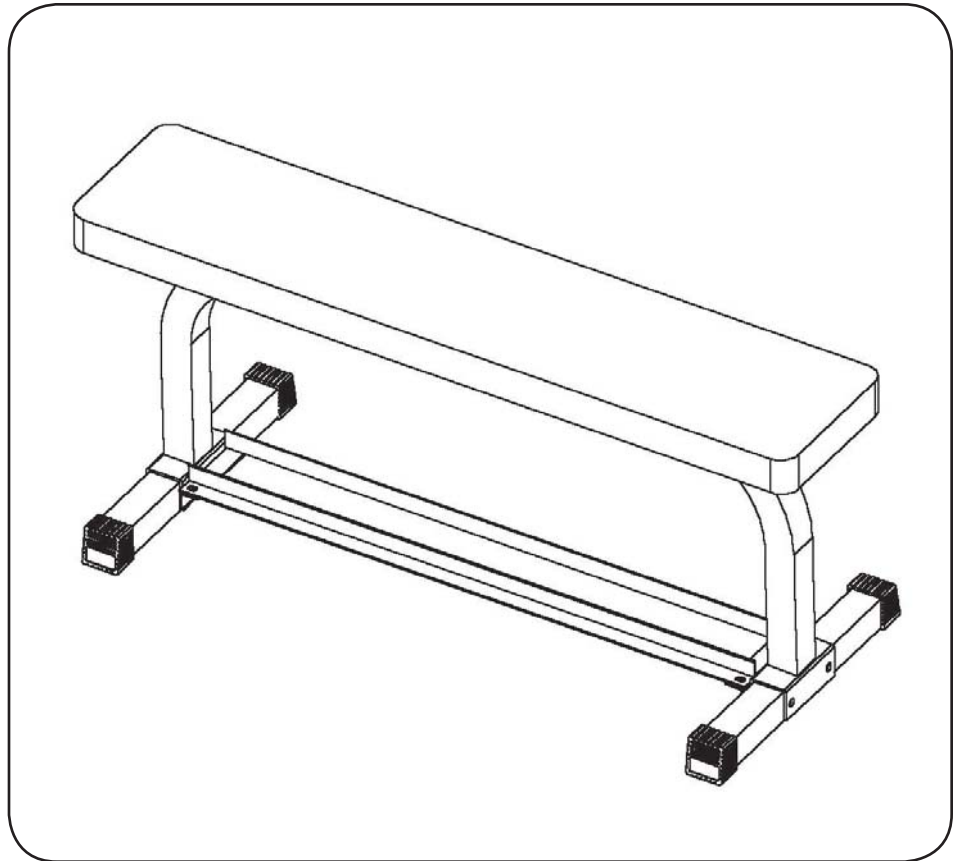

Model Name :ST-FBR

Manufactured Date :

PO # :

Model Name Decal Location

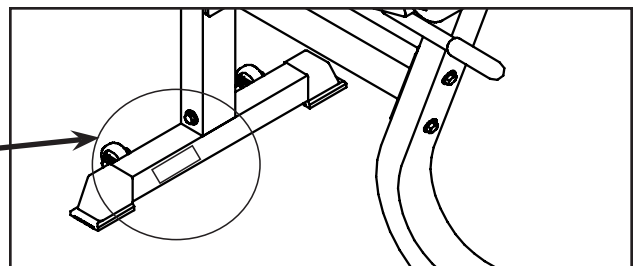

215-00091
08/06 Rev B

Table of Contents



SAFETY INFORMATION	3
ASSEMBLY	4
PARTS LIST	5
WARRANTY	6

Safety Information



Please read all instructions carefully before using this product.

SAFETY TIPS

Consult with your physician before engaging in any vigorous exercise. Know your heart rate and/or pulse as well as your physician-recommended heart rate training zone. Proper medical clearance is recommended for anyone beginning an exercise program especially if you are 35 years of age or older or suffer from heart respiratory problems.

- Warm-up before any exercise program with 8 minutes of aerobic-like activity followed by stretching from head to toe.
- Wear comfortable clothes that allow freedom of movement and are not tight or restricting.
- Wear comfortable shoes made with good support and non-slip soles.
- Breathe naturally, never holding your breath during an exercise.
- Perform exercises consistently with proper technique and pass through a full range of motion.
- Increase resistance by adding heavier weights. Decrease resistance by using lighter weights.
- Always use a spotter for safety.
- Avoid over-training. You should be able to carry on a conversation while exercising.
- After an exercise session. Cool down with slow stretching, cycling or walking.

EXERCISE DEFINITIONS:

Sets: A set is one complete routine of exercises. Complete 1-3 sets for each exercise.

Repetitions: (referred to as reps) Is the number of times you perform an exercise in a row. We recommend beginning with 6 reps and increasing up to 12 reps as indicated below.

Novice: Start with one set of 8-12 reps. Once you can complete the entire set of 12 reps consecutively, progress to the intermediate level.

Intermediate: Complete 2 sets of 8-12 reps once you can complete two sets of 12 reps consecutively, progress to the advanced level.

Advanced: Complete 3 sets of 12 reps

DISCLAIMER:

Keys Fitness is not responsible for the misuse of any of its products or for any injury sustained while using any Keys Fitness product. The consumer uses any or all of Keys Fitness Products at their own risk.

BEFORE YOU BEGIN:

Before you begin assembly of your Keys Fitness product, please take a moment to review the hardware and parts list on the following pages. Each part has been illustrated and numbered for easy identification.

Check this list against the contents of your package to make sure you have all required parts. If any parts are missing, please do not return this product to the store. Contact our service department immediately at **1-888-340-0482** and we will rush you any parts you may require.

Assembly

Unpack all parts and place them in a clear area. Be sure to remove all packing material.

NOTE: Hand Tighten bolts and nylon nuts until machine is fully assembled.

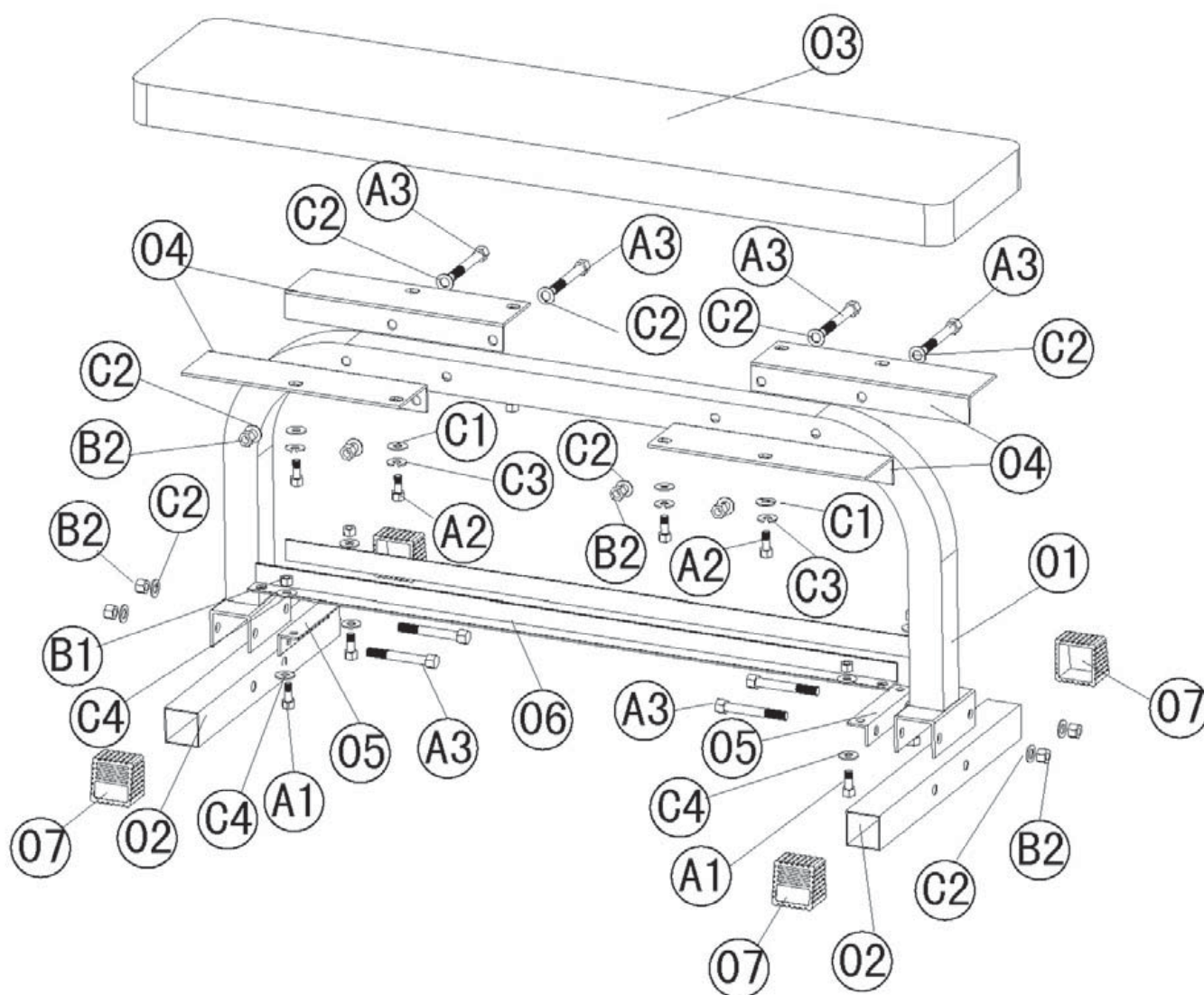

ST-FBR Parts List Rev A

Ref #	Part #	Description	Qty
1	223-00870	MAIN FRAME, ST-FBR	1
2	223-00871	LEG BASE, ST-FBR	2
3	228-00197	PAD, ST-FBR	1
4	219-00489	SEAT SUPORT, RIGHT ST-FBR	2
5	219-00103	LINK RACK M-FBR/ST-FBR	2
6	223-00324	DUMBELL RACK SUPPORT M-FBR/ST-FBR	2
7	206-00064	2" SQUARE END CAP	4
8	219-00488	SEAT SUPORT, LEFT ST-FBR	2
A1	202-00286	SMALL HEX BOLT, M10X20	4
A2	202-00296	HEX BOLT, M10X20	8
A3	202-00443	HEX BOLT M12X80	8
B1	202-00168	AIRCRAFT NUT, M10 M-PR/ST-FBR	4
B2	202-00285	AIRCRAFT NUT, M12	8
C1	202-00420	WASHER 10	8
C2	202-00421	WASHER 8	12
C3	202-00284	SPRING WASHER, D10	8
C4	202-00287	SMALL WASHER 10	8
#	202-00444	BOLT PACK, M-FBR/ST-FBR	1
#	215-00091	MANUAL ST-FBR	1

KEYS FITNESS PRODUCTS, L.P. STRENGTH TRAINER WARRANTY

Keys Fitness Products L.P. warrants this product for a period of 90 days on parts and lifetime on the frame from the original date of purchase. This warranty covers the product from defects in materials and workmanship for the original purchaser. Using this product for commercial purposes, products damaged by misuse, abuse, or from shipping, moving and storage will void this warranty.

Replacement parts are available from Keys Fitness Products L.P.

To contact us for customer service or replacement parts, call 1-888-340-0482.

CUSTOMER SERVICE

If you have any questions regarding this or any Keys Fitness product, or if we may be of assistance in any way, please do not hesitate to call our toll free number 1-888-340-0482.



Keys Fitness Products, L.P.
4009 Distribution Drive, Suite 250
Garland, Texas 75041
Customer Service: 1-888-340-0482