

# Strength SERIES Trainer

## ST-DB2 2'DUMBBELL RACK OWNERS MANUAL

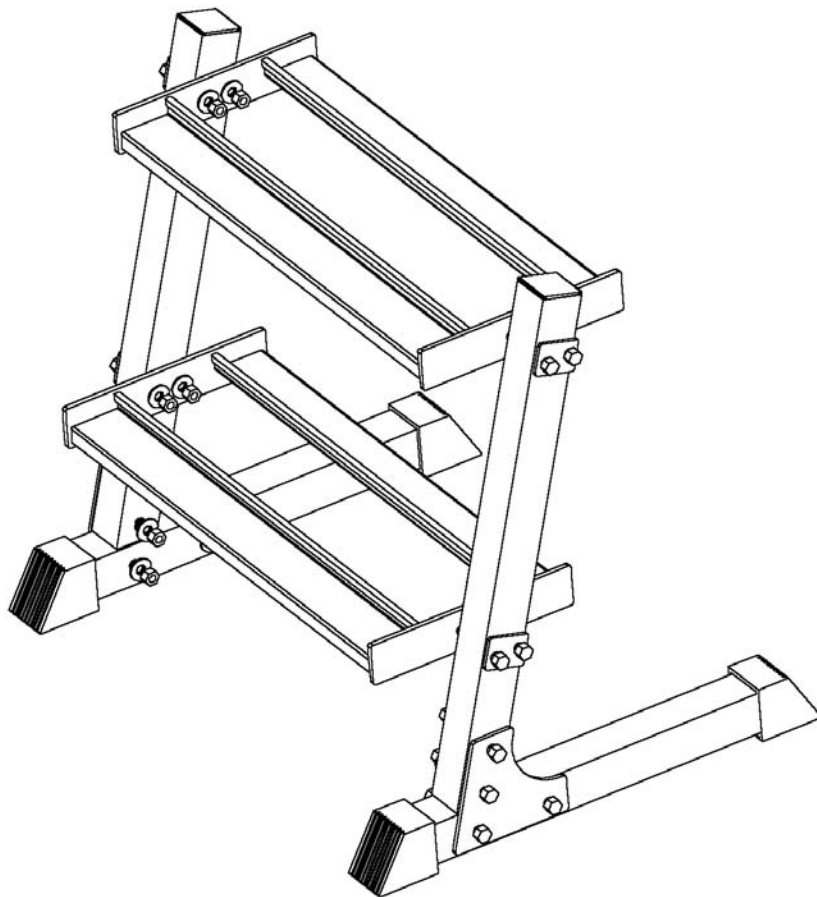

**INCLUDES:**  
SAFETY NOTICE  
EXPLODED DRAWING  
PARTS LIST  
WARRANTY  
ORDERING PARTS



keysfitness.com

Please read all instructions carefully before using this product

## **SAFETY TIPS**

Consult with your physician before engaging in any vigorous exercise. Know your heart rate and/or pulse as well as your physician-recommended heart rate training zone. Proper medical clearance is recommended for anyone beginning an exercise program especially if you are 35 years of age or older or suffer from heart respiratory problems.

- Warm-up before any exercise program with 8 minutes of aerobic-like activity followed by stretching from head to toe.
- Wear comfortable clothes that allow freedom of movement and are not tight or restricting.
- Wear comfortable shoes made with good support and non-slip soles.
- Breathe naturally, never holding your breath during an exercise.
- Perform exercises consistently with proper technique and pass through a full range of motion.
- Increase resistance by adding heavier weights. Decrease resistance by using lighter weights.
- Always use a spotter for safety.
- Avoid over-training. You should be able to carry on a conversation while exercising.
- After an exercise session. Cool down with slow stretching, cycling or walking.

## **EXERCISE DEFINITIONS**

**Sets:** A set is one complete routine of exercises. Complete 1-3 sets for each exercise.

**Repetitions:** (referred to as reps) are the number of times you perform an exercise in a row. We recommend beginning with 6 reps and increasing up to 12 reps as indicated below.

**Novice:** start with one set of 8-12 reps. Once you can complete the entire set of 12 reps consecutively, progress to the intermediate level.

**Intermediate:** complete 2 sets of 8-12 reps once you can complete two sets of 12 reps consecutively. Progress to the advanced level.

**Advanced:** complete 3 sets of 12 reps

## **DISCLAIMER:**

Keys Fitness Products is not responsible for the misuse of any Keys Fitness Products nor for any injury sustained while using any Keys Fitness Products. The consumer uses any or all of Keys Fitness Products at their own risk.

## **BEFORE YOU BEGIN**

Before you begin assembly of your keys fitness product, please take a moment to review the hardware and parts list on the following pages. Each part has been illustrated and numbered for easy identification. Check this list against the contents of your package to make sure you have all required parts. If any parts are missing, please do not return this product to the store. Contact our service department immediately at 1-888-340-0482 and we will rush you any parts you may require.

## **TOOLS REQUIRED**

You will need two adjustable wrenches for assembly

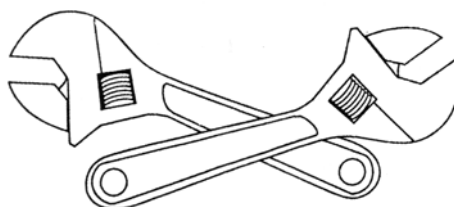

## EXPLODED DRAWING

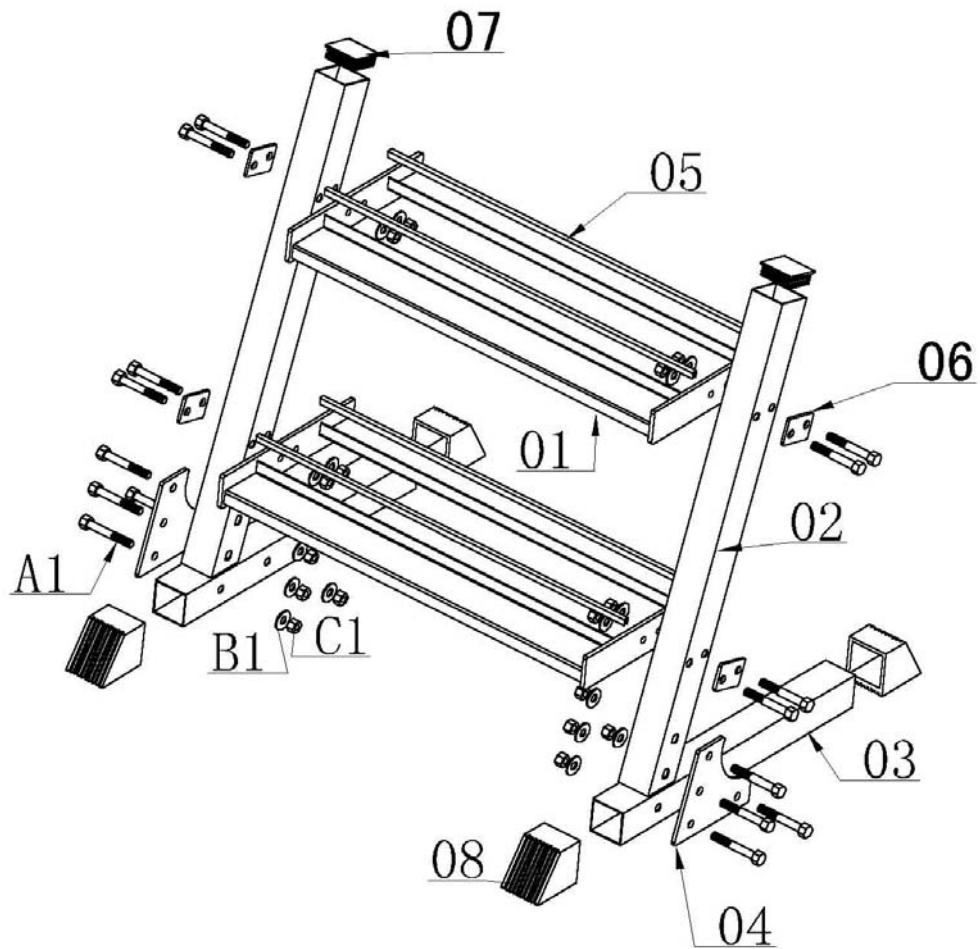

## PARTS LIST

Part no.	Description	Qty.	Remarks
1	Dumbbell Tray	2	
2	Main Frame	2	
3	Base	2	
4	L Shape Support Plate	2	
5	Protective sleeve	4	Pre-assembled
6	Sq. plate	4	
7	Inner Plug 50x50	2	Pre-assembled
8	End cap	4	Pre-assembled
A1	M10X70 mm Bolt	16	
B1	D10XD25 mm Washers	16	
C1	M10 Aircraft Nut	16	



## **WARRANTY**

Keys Fitness Products LP warrants this product for a period of 90 days on parts and lifetime on the frame from the original date of purchase. This warranty covers the product from defects in materials and workmanship for the original purchaser. Using this product for commercial purposes, products damaged by misuse, abuse, or from shipping, moving and storage will void this warranty.

Replacement parts are available from Keys Fitness Products LP. To contact us for customer service or replacement parts, call 1(888)340-0482.

## **CUSTOMER SERVICE**

If you have any questions regarding this or any Keys Fitness product, or if we may be of assistance in any way, please do not hesitate to call our toll free number 1(888)340-0482.

Remember, before using any exercise product, consult a physician.

**Keys Fitness Products, LP**

**4009 Distribution Drive, Suite 250**

**Garland, Texas 75041**

**keysfitness.com**