

**1-888-340-0482**  
**Monday-Friday**  
**8:30-5:30 Central Time**



**Keys Fitness Products, L.P.**  
**4009 Distribution Dr.**  
**Suite 250**  
**Garland, Texas 75041**



## **OWNER'S MANUAL**

### **QUESTIONS?**

Call Our Toll Free  
Keys Fitness Helpline  
1-888-340-0482



**Keys Fitness Products, L.P.**  
**P.O. Box 551239**  
**Dallas, Texas 75355-1239**

### **CAUTION!**

Please read the precautions and instructions in this manual before using this equipment. Please save this manual for future reference.



**Keys Fitness is committed to quality products that demonstrate our commitment to excellence!**

**ALLIANCE RECUMBENT BIKE  
Model: 920R**

**Questions?**

*Please call if:*

- you need assistance about operating your exercise bike
- parts are missing
- parts become worn or need to be replaced

**1-888-340-0482  
Monday-Friday  
8:30-5:30 Central Time**

*When requesting information please have the following available:*

- The Name
- The Model
- The Part Number
- The Description

**KEYS FITNESS PRODUCTS, LP - LIMITED WARRANTY**

**PRODUCT:** ALLIANCE 920 RECUMBENT EXERCISE BIKE  
**HOME USE WARRANTY:** Frame: Lifetime, Parts: 2 Years, Labor: 1 Year

This Limited Warranty applies in the United States and Canada to products manufactured or distributed by Keys Fitness Products, LP ("Keys") under the KEYS brand name. The warranty period to the original purchaser is listed above in the table.

Keys warrants that the Product you have purchased for use from Keys or from an authorized Keys reseller is free from defects in materials or workmanship under normal use during the warranty period. Your sales receipt, showing the date of purchase of the Product, is your proof of purchase. This warranty only extends to you, the original purchaser. It is not transferable to anyone who subsequently purchases the Product from you. It excludes expendable parts (wear items). Wear items pertain to components that might need to be replaced due to normal wear and tear. These items vary per product but will include computer overlays, pedal straps, rope cords, seats, grips, chains, bottom bracket assemblies, pads, upholstery, pulleys, bearings, etc. Please contact a Keys Fitness customer service representative for specifics on wear items. This Limited Warranty becomes VALID ONLY if the product is purchased through a Keys Fitness authorized dealer unless otherwise authorized by Keys Fitness in writing.

During the warranty period Keys will repair or replace (at Keys' option) the product if it becomes defective, malfunctions, or otherwise fails to conform with this Limited Warranty under normal use. In repairing the Product, Keys may replace defective parts, or at the option of Keys, serviceable used parts that are equivalent to new parts in performance. All exchanged parts and Products replaced under this warranty will become the property of Keys. Keys reserves the right to change manufacturers of any part to cover any existing warranty.

This warranty DOES NOT COVER shipping charges, export taxes, custom duties and taxes, or any other charges associated with transportation of the parts or Product.

To obtain warranty service, you must contact a Keys authorized retailer, service technician or Keys Fitness at our phone numbers located in this manual. Any parts determined to be defective must be returned to Keys to obtain warranty service. You must prepay any shipping charges, export taxes, custom duties and taxes, or any other charges associated with transportation of the parts or Product. In addition, you are responsible for insuring any parts or Product shipped or returned. You assume the risk of loss during shipment. You must present Keys with proof-of-purchase documents (including the date of purchase). Any evidence of alteration, erasing or forgery of proof-of-purchase documents will be cause to void this Limited Warranty.

This warranty does not extend to any product not purchased from Keys or from an authorized Keys reseller. This Limited Warranty does not extend to any Product that has been damaged or rendered defective: (a) as a result of accident, misuse, or abuse; (b) by the use of parts not manufactured or sold by Keys; (c) by modification of the Product or normal wear and tear; (d) operation on incorrect power supplies; or (e) as a result of service by anyone other than Keys, or an authorized Keys warranty service provider. Product on which the serial number has been defaced or removed is not eligible for warranty service. Should any Product submitted for warranty service be found ineligible, an estimate of repair cost will be furnished and the repair will be made if requested by you upon Keys' receipt of payment or acceptable arrangements for payment.

EXCEPT AS EXPRESSLY SET FORTH IN THIS WARRANTY, KEYS MAKES NO OTHER WARRANTIES, EXPRESSED OR IMPLIED, INCLUDING ANY IMPLIED WARRANTIES OF MERCHANTABILITY AND FITNESS FOR A PARTICULAR PURPOSE. KEYS EXPRESSLY DISCLAIMS ALL WARRANTIES NOT STATED IN THIS LIMITED WARRANTY. ANY IMPLIED WARRANTIES THAT MAY BE IMPOSED BY LAW ARE LIMITED TO THE TERMS OF THIS LIMITED WARRANTY. NEITHER KEYS NOR ANY OF ITS AFFILIATES SHALL BE RESPONSIBLE FOR INCIDENTAL OR CONSEQUENTIAL DAMAGES. SOME STATES DO NOT ALLOW LIMITATIONS ON HOW LONG AN IMPLIED WARRANTY LASTS OR THE EXCLUSION OR LIMITATION OF INCIDENTAL OR CONSEQUENTIAL DAMAGES, SO THE ABOVE LIMITATIONS OR EXCLUSION MAY NOT APPLY TO YOU. This Limited Warranty gives you specific legal rights and you may also have other rights that may vary from state to state. This is the only express warranty applicable to Keys-branded products. Keys neither assumes nor authorizes anyone to assume for it any other express warranty.

PLEASE SEND IN THE ATTACHED WARRANTY CARD WITHIN TEN (10) DAYS OF PURCHASE TO REGISTER YOUR UNIT WITH KEYS FITNESS PRODUCTS, LP.

MAIL WARRANTY CARD TO:  
KEYS FITNESS PRODUCTS, PO BOX 551239, DALLAS, TX 75355

## Before You Start

Thank you for purchasing a Keys exercise bicycle! This quality product you have chosen was designed to meet your needs for cardiovascular exercise.

Prior to assembly, remove components from the box and verify that all the listed parts were supplied. Assembly instructions are described in the following steps and illustrations.

## Important Safety Information WARNING!

- 1) Before using this exercise bicycle or starting any exercise program, consult your physician. This is especially important for persons over the age of 35 and/or persons with pre-existing health problems. Keys Fitness Products LP assumes no responsibility for personal injury or property damage sustained by or through the use of this product.
- 2) To reduce the risk of electrical shock, burns, fire or other possible injuries to the user, it is important to review this manual and the following precautions before operation.

## Safety Precautions and Tips

It is the owner's responsibility to ensure that all users of this exercise bike have read the Owner's Manual and are familiar with warnings and safety precautions.

- This exercise bike has a maximum user capacity of 300 pounds.
- The Alliance Exercise Bike should only be used on a level surface and is intended for indoor use only. It should not be placed in a garage, patio or near water. Keys recommends an equipment mat be placed under the bicycle to protect the floor or carpet and for easier cleaning.
- Wear comfortable, good-quality walking or running shoes and appropriate clothing. Do not use this exercise bike with bare feet, sandals, socks or stockings!
- Always examine your exercise bike before using to ensure all parts are in working order.
- Do not leave children unsupervised near or on the exercise bicycle.
- Never operate the exercise bicycle where oxygen is being administered or where aerosol products are being used.
- Never insert any object or body parts into any opening.
- Service to your Alliance Exercise Bike should only be performed by an authorized service representative, unless authorized and/or instructed by a Keys technician. Failure to follow these instructions will void the warranty.

## Assembly of Alliance 920 Recumbent Bike

REMOVE ALL SECURITY TAPE AND WRAPPING BEFORE BEGINNING.

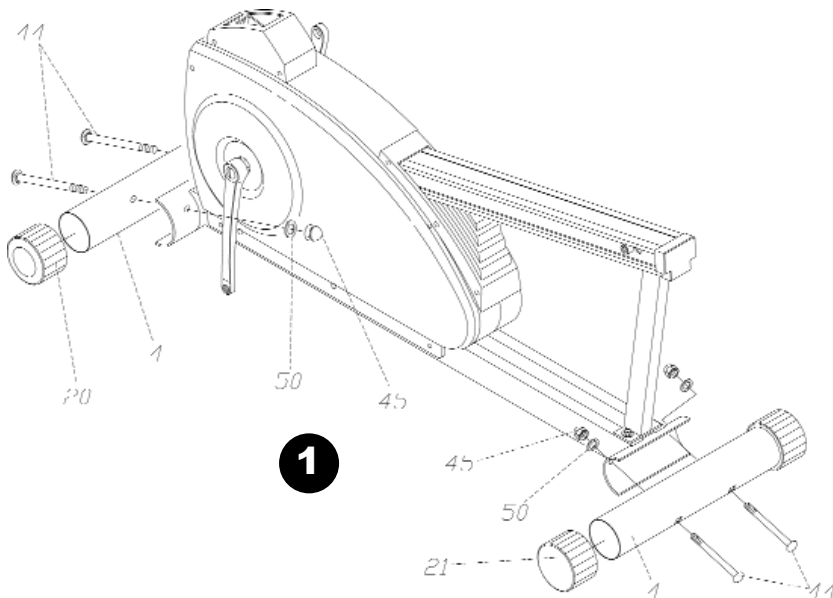

- 1.** Attach foot tubes (4) to the frame by using the carriage bolts (44), flat washers (50) and cap nuts (45) provided. Make sure the foot tube with wheels is assembled onto the front of the unit.

- 2a.** Attach the rear handlebar (22) to the seat carriage (3) with the flat washers (50) and screws (79) provided. Connect the seat cushions (9,10) to the seat carriage (3) with the washers (78) and screws (80).

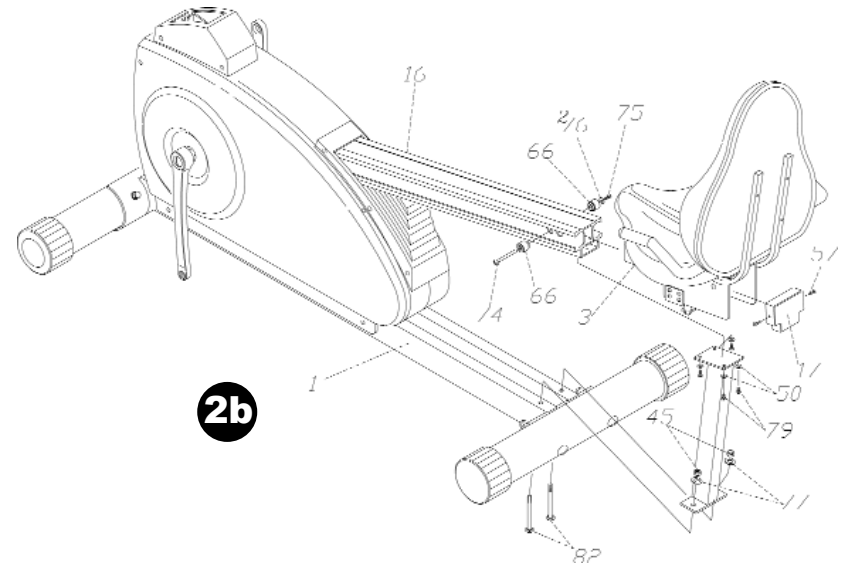
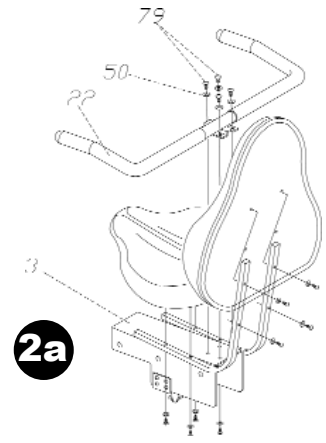

- 2b.** First remove the support tube (24), from the main frame (1). Slide the assembled seat carriage onto the carriage tube (16). Re-assemble the support tube (24). Attach the end cap (17) with screws (57) and rear carriage tube rubber stoppers (66) with bolts (74, 75) and washer (76).

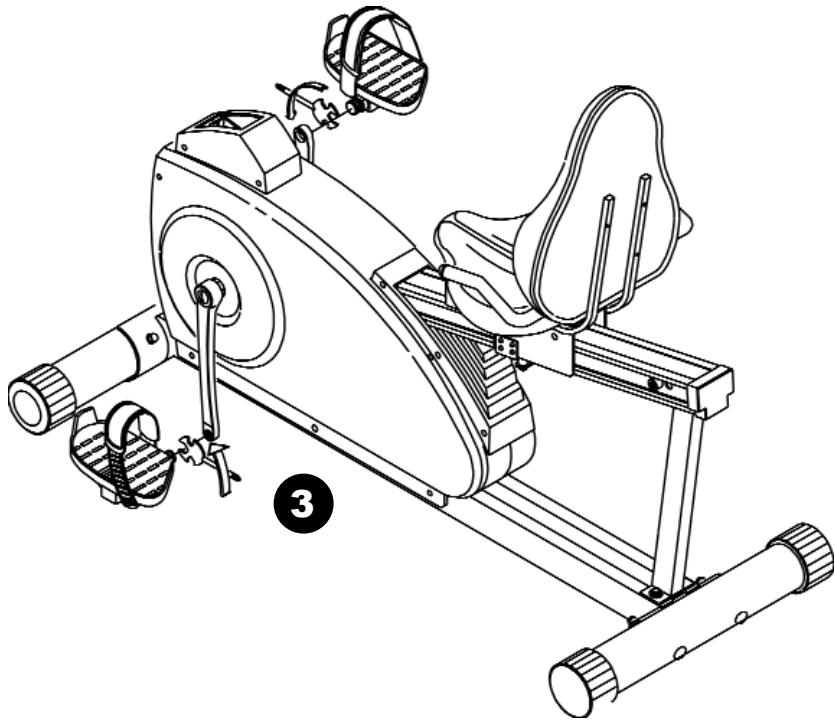

- 3.** Attach pedals (30, 31). Axles of pedals are branded “L” and “R.” The pedal marked “R” goes on the right hand side of the bike and the one marked “L” on the left hand side. Tighten the left pedal by turning counter-clockwise and the right pedal by turning clockwise.

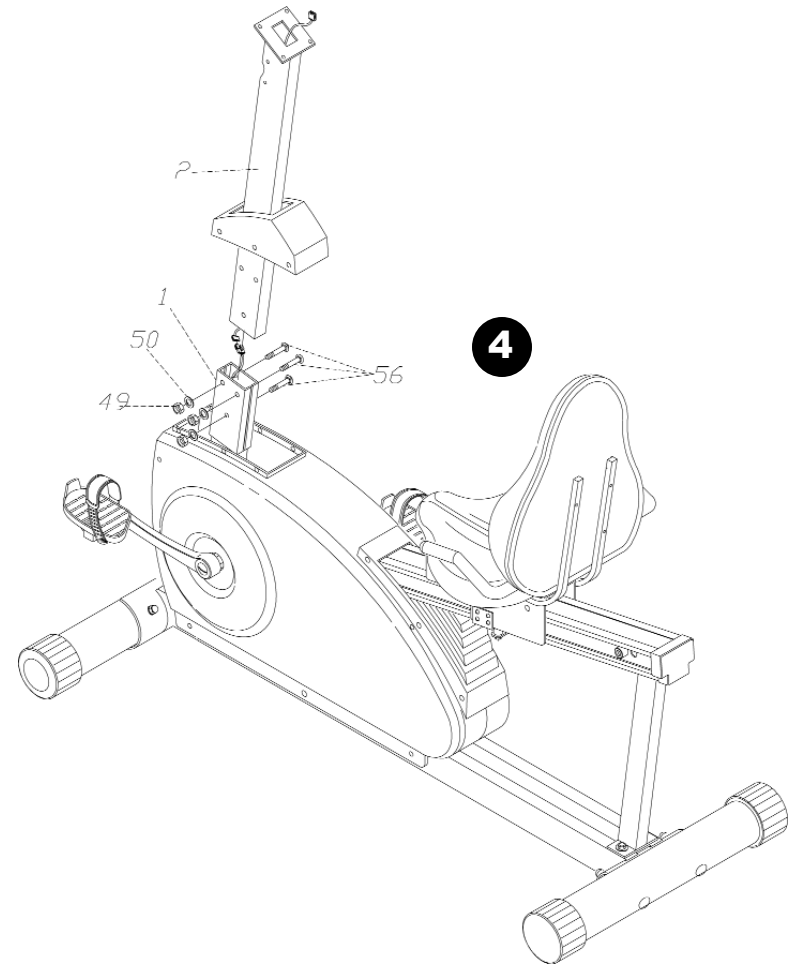

- 4.** Slide the console tube (2) through the console tube collar (14). Connect the computer cable in the console tube (2) to the computer cable in the main frame. Attach the console tube (2) to the frame (1) with the locknuts (49), flat washers (50) and screws (56) provided. Attach the console tube collar (14) to the main frame (1) with screws (57).

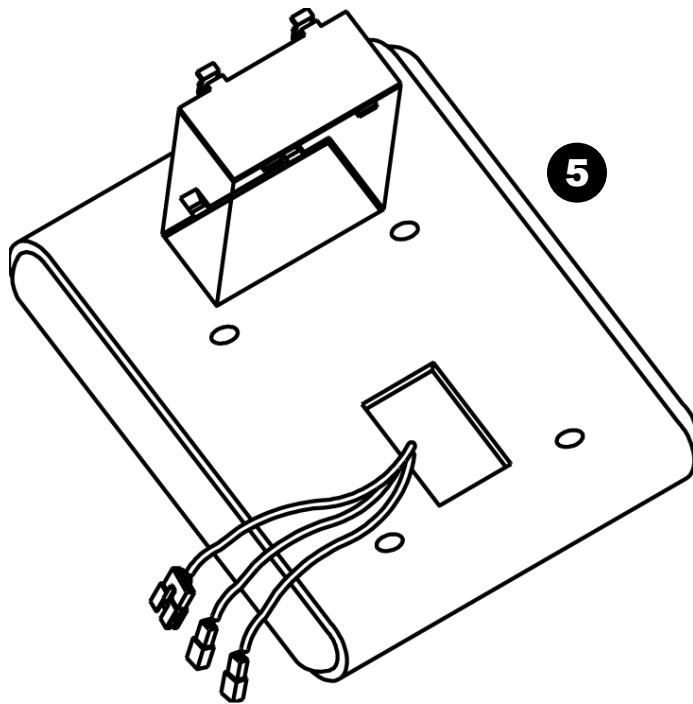

- 5.** Load your console with the batteries provided. Batteries are 4 “AA” size.

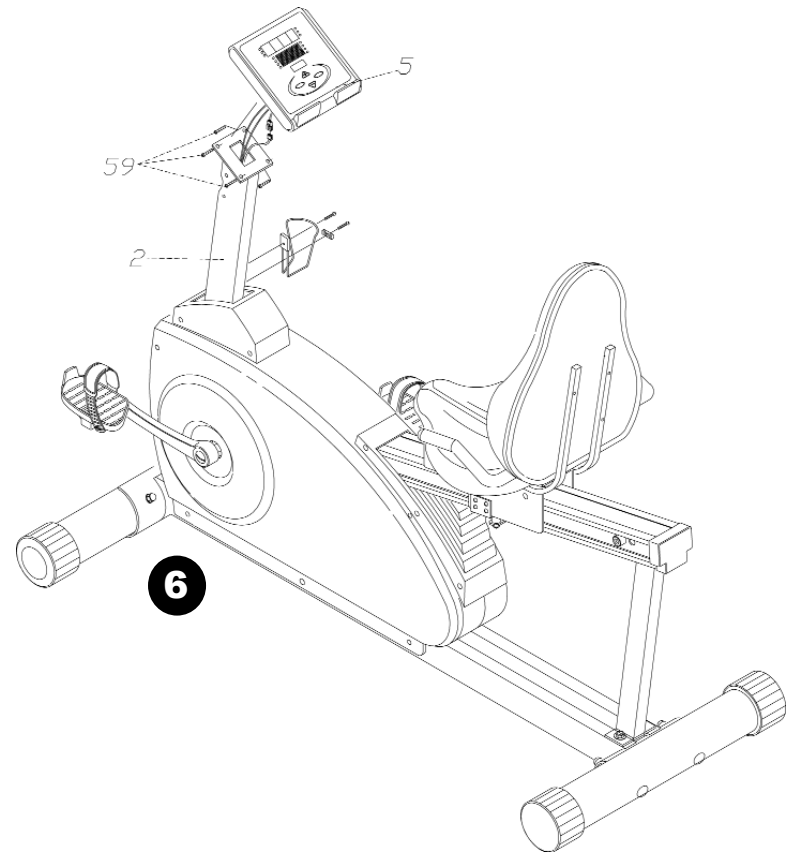

- 6.** Connect the computer cable at the top of the console tube (2) to the console (5). Both computer cable connections have white ends. Feed the pulse wires from the console (5) down into the console tube (2) and out the rear hole in the handlebar area. Attach the console tube (2) to the console (5) with the screws (59) provided and already attached to back of the console (5). Attach bottle rack to console tube (2).

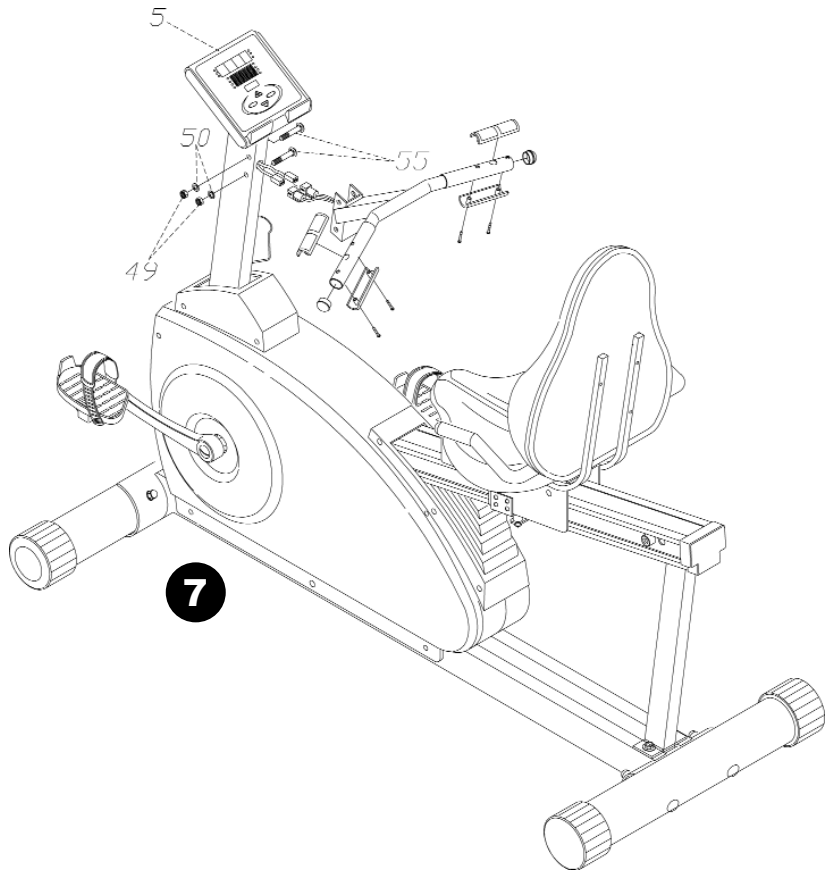

- 7.** Attach the pulse wires in the front handlebar (23) to the wires from the console (5). Connect the front handlebar (23) to the console tube with the locknuts (49), flat washers (50) and screws (55) provided. Make sure not to “pinch” any of the pulse wires when connecting the handlebar to the console tube.

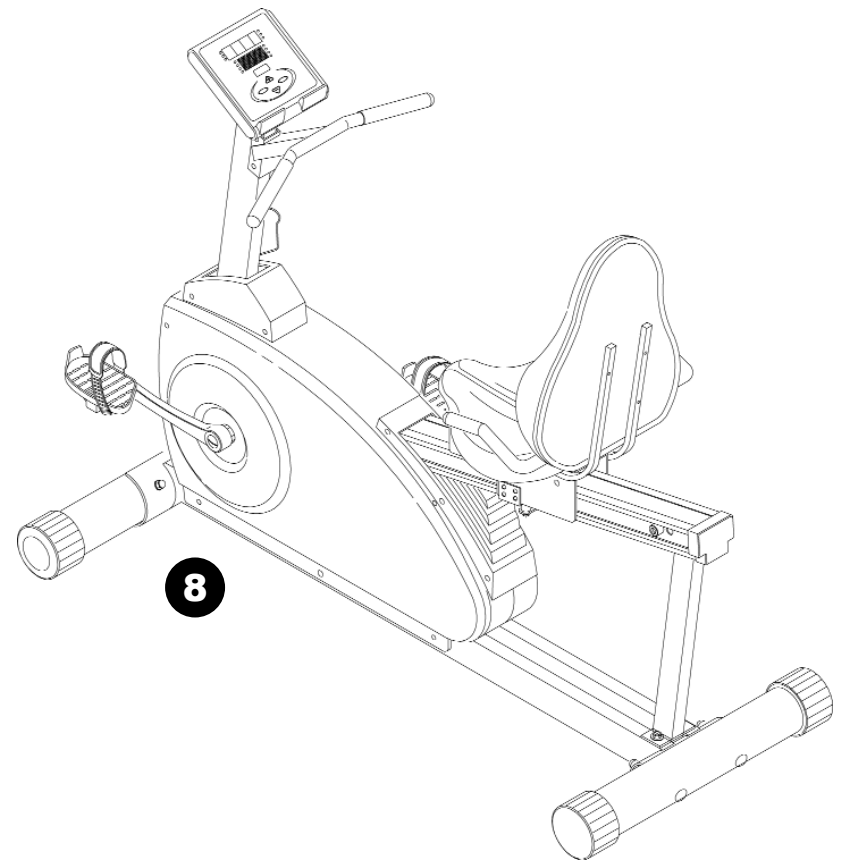

- 8.** You have completed the assembly of your new Alliance bike.

## 920R EXPLODED VIEW

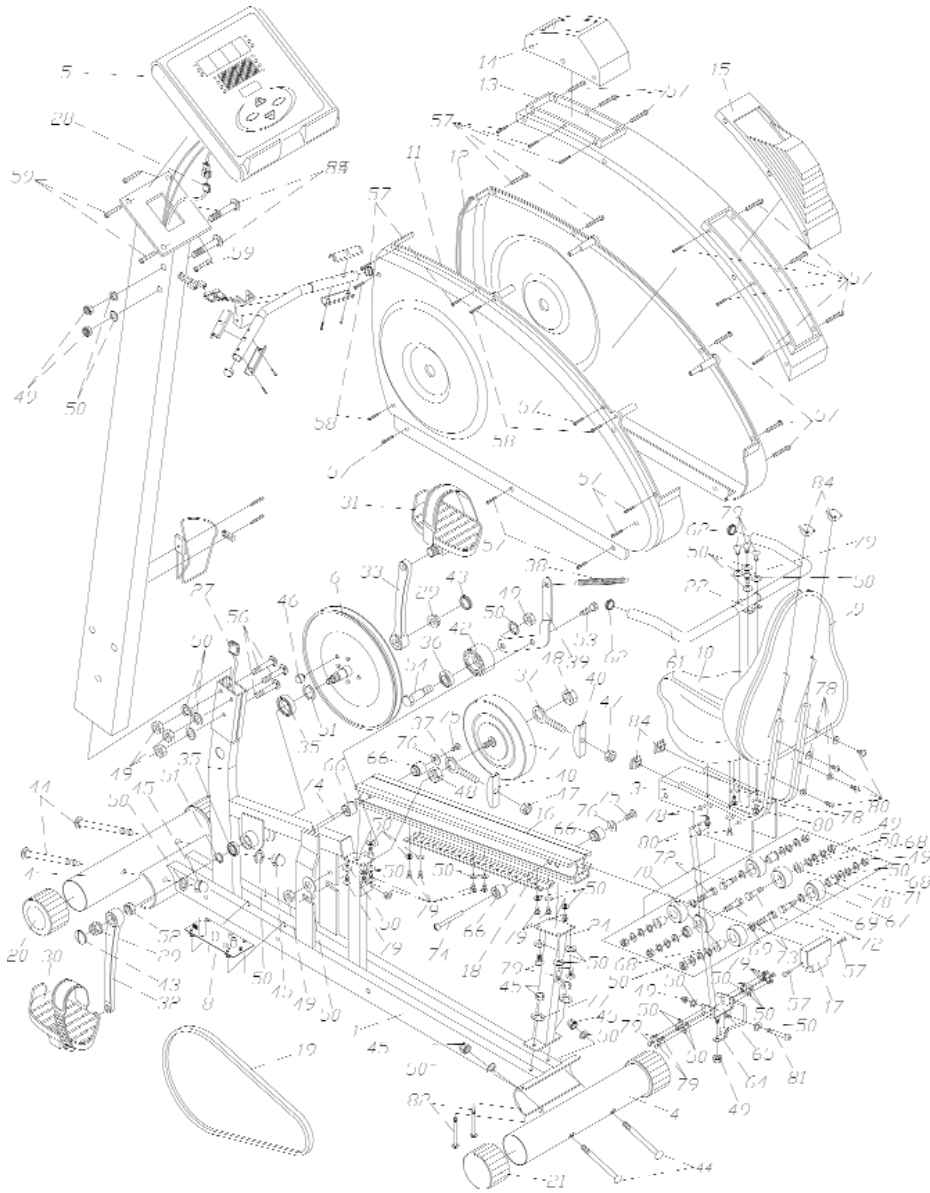

## 920R PARTS LIST

#	PART	QTY	#	PART	QTY
1	FRAME	1	43	CRANK CENTRAL CAP	2
2	CONSOLE TUBE	1	44	M8X85mm CARRDIAGE BOLT	4
2-1	BOTTLE RACK	1	45	M8 CAP NUT	4
3	SEAT CARRIAGE	1	46	M6 LOCKNUT	4
4	FOOT TUBE	2	47	6mm HEX NUT	2
5	CONSOLE	1	48	M10 CAP NUT	2
6	PULLEY	1	49	M8 LOCKNUT	18
7	GENERATOR	1	50	M8 IDX18.8mm FLAT WASHER	38
8	CONTROLLER BOARD	1	51	M20X32X2mm WASHER	2
9	SEAT CUSHION	1	52	CRANK NUT	2
10	BACK SEAT CUSHION	1	53	M8X17mm SCREW	1
11	BOTTOM LEFT COVER	1	54	M8X38mm SCREW	1
12	BOTTOM RIGHT COVER	1	55	M8X57mm SCREW	3
13	TOP COVER	1	56	M8X60mm SCREW	3
14	CONSOLE TUBE COLLAR	1	57	TP4X12mm SCREW	30
15	CONNECTING COVER	1	58	TP5X50mm SCREW	4
16	CARRIAGE TUBE	1	59	M5X10mm SCREW	4
17	END CAP	1	60	M6X45 MACHINE SCREW	4
18	ADJUSTING PLATE	2	61	REAR SLEEVE	2
19	"V" BELT	1	62	REAR BALL PLUG	2
20	WHEEL	2	63	FRONT BALL PLUG	2
21	FOOT CAP	2	64	CAM LOCK	1
22	REAR HANDLEBAR	1	65	SEAT CARRIAGE BRACKET	1
23	FRONT HANDLEBAR	1	66	RUBBER STOPPER	4
24	SUPPORT TUBE	1	67	SMALL ROLLER	6
25	HAND PULSE	2	68	M8 WAVED WASHER	6
26	PULSE WIRE	2	69	M13 WAVED WASHER	4
27	CONTROLLER EXT. WIRE	2	70	8*13mm BUSHING	4
28	CONTROLLER WIRE	1	71	RETAINING RING	2
29	9mm NUT	2	72	8*34mm SCREW	4
30	LEFT PEDAL	1	73	BIASED 8*34mm SCREW	2
31	RIGHT PEDAL	1	74	11*58mm SCREW	2
32	LEFT CRANK	1	75	M6x15mm SCREW	2
33	RI GHT CRANK	1	76	6x13mm WASHER	2
34	LOCKING KNOB	1	77	8x169mm WASHER	2
35	6004 PRECISE BEARING	2	78	6x16mm WASHER	8
36	608 PRECISE BEARING	1	79	M8x15mm SCREW	12
37	EYEBOLT	2	80	ROUND HEAD M6x60mm SCR	8
38	SPRING	1	81	M8x45 MACHINE SCREW	1
39	BELT TENSION BRACKET	1	82	M8x70mm SCREW	2
40	ADJUSTMENT CHANNEL	2	83	FRONT SLEEVE	2
41	SENSOR	1	84	SQUARE CAP	4
42	IDLER PULLEY	1			



## 920R Display Instructions

Your Alliance 920R is equipped with a programmable monitor to help you track your progress and motivate you to reach your fitness goals. In order to set your programmable monitor, you must begin pedaling.

### 1. Key Functions:

- RESET** - Resetting all cumulative values to zero.
- ENTER** - Confirming of “set values,” “selections” and “Quick Start” function.
- ▲ ▼** Increasing and decreasing the set values and resistance during Operation.

### 2. Display:

There are three displays in the console:

**W1= display window on top, W2=display window in middle and W3= last display window at bottom of console.**

- W1** = Display every cumulative value including TIME, CALORIES, DISTANCE, SPEED and RPM.

.8..8.'8''8'

- W2** =

- display profile of every program.
- display operation information in input mode by rolling characters.
- display “score” when “Fitness Test” program is finished. (see step 4D)

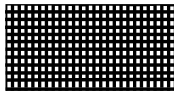

- W3** = Display “Heart Rate” and ”Workout Level.”

8 8 8

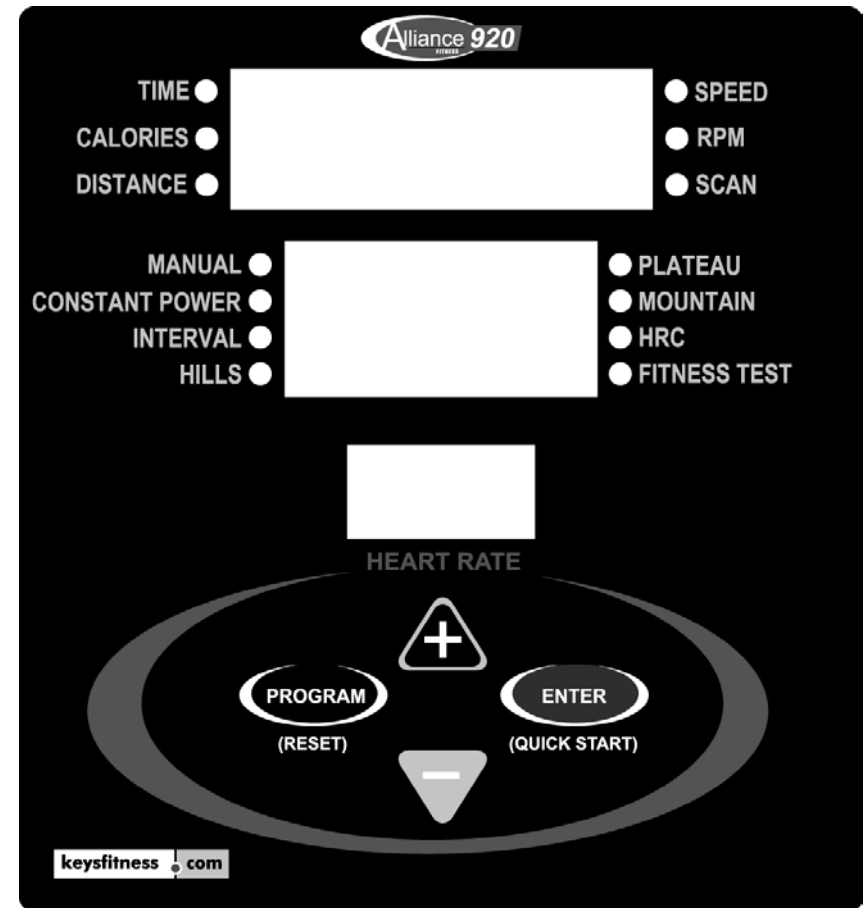

### 3. Indicator:



- TIME
- CALORIES
- SPEED
- RPM
- SCAN
- MANUAL
- CONSTANT POWER
- INTERVAL
- HILLS
- PLATEAU
- MOUNTAIN
- HRC
- FITNESS TEST

### 4. Operation Process:



#### A. "QUICK START" MODE:

- Press **RESET** key, all LED of the console turns on for 2 seconds.
- Press **ENTER** key during 2 seconds in step 1, the console is in "Quick Start" mode, and displays the profile of "Manual" program.
- "TIME" and "SCAN" indicators of **(W1)** turn on. Operation time is counting up and every display value of **(W1)** is scanning per 4 seconds interval.
- (W2)** displays each column as 1 minute of operation then the completed column will shift to the right.
- Exerciser can adjust working level by  keys
- Stop this mode by pressing **RESET** key.

#### B. "MANUAL," "CONSTANT POWER," "INTERVAL," "HILLS," "PLATEAU" and "MOUNTAIN" programs.

- Press **RESET** key, **(W2)** displays **ENTER WEIGHT**
- Preset weight of exerciser by  keys.
- Press **ENTER** key, **(W2)** displays "SELECT PROGRAM".
- Choose desired program by  keys and indicators of desired program turn on. Corresponding profile of program is displayed on **(W2)**.
- Press **ENTER** key, **(W2)** displays "WORKOUT TIME" and **(W1)** displays preset time value of last operation.
- Set new time value by  keys.
- Press **ENTER** key.
- (W2)** displays "PRESS ENTER TO BEGIN"
- Press **ENTER** key and start to exercise.

#### C. "HRC" program.

- Step 1 to 6 is similar to **B**, but "HRC" program also requires age and target heart rate.
- Press **ENTER** key, **(W2)** displays "ENTER AGE" and **(W1)** displays preset age of last operation.
- Set age of exerciser by  keys.
- Press **ENTER** key, **(W2)** displays "TARGET HART RATE," **(W1)** displays preset value of target heart rate, which depends on age of the exerciser.
- Choose target heart rate by  keys.
- Press **ENTER** key.
- (W2)** displays "PRESS ENTER TO BEGIN"
- Press **ENTER** key and start to exercise.

#### D. "FITNESS TEST" program.

This 8 minute test program calculates your approximate oxygen uptake. At the end of the program you will receive a Fit Test Score which is the equivalent of your approximate VO2 max. This number should be used as a reference to gauge aerobic improvements over an extended workout protocol. Please use the following table for reference only:

#### Standards for evaluating aerobic fitness (VO2 max)

Age	Low	Fair	Average	Good	High
<b>Women</b>					
20-29	<24	24-30	31-37	38-48	>49
30-39	<20	20-27	28-33	34-44	>45
40-49	<17	17-23	24-30	31-41	>42
50-59	<15	15-20	21-27	28-37	>38
60-69	<13	13-17	18-23	24-34	>35
<b>Men</b>					
20-29	<25	25-33	34-42	43-52	>53
30-39	<23	23-30	31-38	39-48	>49
40-49	<20	20-26	27-35	36-44	>45
50-59	<18	18-24	25-33	34-42	>43
60-69	<16	16-22	23-30	31-40	>41

1. Step 1-4 is similar to B, but “FITNESS TEST” program also requires age and sex of user.
5. Press **ENTER** key, (**W2**) displays “ENTER AGE” and (**W1**) displays preset age of last operation.
6. Set age of the exerciser by **▲▼** keys.
7. Press **ENTER** key, (**W2**) displays “SET SEX,”
8. Choose “MALE” or “FEMALE” by **▲▼** keys, (**W1**) displays **MALE** or **FEMALE** correspondingly.
9. Press **ENTER** key, (**W2**) displays “PRESS ENTER TO BEGIN”
10. Press **ENTER** key and start to exercise.

### **E. START MODE**

1. Each column of (**W2**) represents one minute of operation when time is being counted up.
2. In (**W2**) presetting time value divided by 16 is equal to each column when operation time is being counted down.
3. Press **ENTER** key to change the “SCAN” function in operation and the corresponding indication of “SCAN” will turn on or off.
4. The exerciser can adjust workout level by using **▲▼** keys in operation except during “FITNESS TEST” program.

### **F. RESULT MODE**

1. When operation time is finished, the console is in “Result state”, (**W1**) displays the following data in 4 second intervals.
  - a. Total operation time.
  - b. Cumulative calories.
  - c. Cumulative distance.
  - d. Average speed.
  - e. Average RPM.
2. **W3** displays “average heart rate”
3. **W2** displays “RESULTS MODE” and shows profiles of every program for 2.5 seconds sequentially, except in “FITNESS TEST” program.
4. **W2** displays “SCORE=000” when “FITNESS TEST” Program is completed.

## Monitoring Your Heart Rate

To obtain the greatest cardiovascular benefits from your exercise workout, it is important to work within your target heart rate zone. The American Heart Association (AHA) defines this target as 60%-75% percent of your maximum heart rate.

Your maximum heart rate may be roughly calculated by subtracting your age from 220. Your maximum heart rate and aerobic capacity naturally decreases as you age. This may vary from one person to another, but use this number to find your approximate effective target zone. For example, the maximum heart rate for an average 40 year-old is 180 bpm. The target heart rate zone is 60%-75% of 180 or 108-135 bpm. See *Fitness Safety* on page 20.

Before beginning your workout, check your normal resting heart rate. Place your fingers lightly against your neck, or against your wrist over the main artery. After finding your pulse, count the number of beats in 10 seconds. Multiply the number of beats by six to determine your pulse rate per minute. We recommend taking your heart rate at these times; at rest, after warming up, during your workout and two minutes into your cool down, to accurately track your progress as it relates to better fitness.

During your first several months of exercising, the AHA recommends aiming for the lower part of the target heart rate zone-60%, then gradually progressing up to 75%.

According to the AHA, exercising above 75% of your maximum heart rate may be too strenuous unless you are in top physical condition. Exercising below 60% of your maximum will result in minimal cardiovascular conditioning.

Check your pulse recovery rate – If your pulse is over 100 bpm five minutes after you stop exercising, or if it's higher than normal the morning after exercising, your exertion may have been too strenuous for your current fitness level. Rest and reduce the intensity next time.

**Fitness Safety** The target heart rate chart indicates average rate zones for different ages. A variety of different factors (including medication, emotional state, temperature and other conditions) can affect the target heart rate zone that is best for you. Your physician or health care professional can help you determine the exercise intensity that is appropriate for your age and condition.

**(MHR) = Maximum Heart Rate**

**(THR) = Target Heart Rate**

**220 - age = maximum heart rate (MHR).**

**MHR x .60 = 60% of your maximum heart rate.**

**MHR x .75 = 75% of your maximum heart rate.**

**For example, if you are 30 years old, your calculations will be as follows:**

**220 - 30 = 190**

**190 x .60 = 114 (low end or 60% of MHR)**

**190 x .75 = 142 (high end or 75% of MHR)**

**30 year-old (THR) Target Heart Rate would be 114-142.**

**See Table on right for additional calculations.**

