



# KeysFitness<sup>®</sup>

## A7e

### Owner's Manual

### Alliance A7e Elliptical

**Customer Service**  
(888) 340-0482

**Keys Fitness Products**  
4009 Distribution Drive  
Suite 250  
Garland, TX 75041

[www.keysfitness.com](http://www.keysfitness.com)

**Model Name : A7e**

**Serial Number :**

*Write down for future reference*



**CAUTION!** Read all precautions and instructions in this manual before using this equipment.

**315-00009**  
**Rev. E 01/06**

# Table of Contents



Important Safety Information	3
Before You Start	4
Assembly	5-9
Console Instructions	10-13
Monitoring Your Heart Rate	14-15
Moving Instructions	16
Warm Up Exercises	17
Parts List	18
Exploded View	19
Warranty Information	20

# Important Safety Information



**WARNING!** Before using this unit or starting any exercise program, consult your physician. This is especially important for persons over the age of 35 and/or persons with pre-existing health problems. The manufacturer or distributor assumes no responsibility for personal injury or property damage sustained by or through the use of this product.

**WARNING!** To reduce the risk of electrical shock, burns, fire, or other possible injuries to the user, it is important to review this manual and the following precautions before operation.

## SAFETY PRECAUTIONS AND TIPS

1. It is the owner's responsibility to ensure that all users of this unit have read the Owner's Manual and are familiar with warnings and safety precautions.
2. This unit has a user maximum capacity of **350** pounds.
3. The unit should only be used on a level surface and is intended for indoor use only. The unit should not be placed in a garage, patio, or near water and should never be used while you are wet. Keys recommends a mat be placed under the unit to protect floor or carpet and for easier cleaning.
4. Follow safety information in regards to plugging in your unit. Do not run the power cord underneath your unit. Do not operate the unit with a damaged or frayed power cord.
5. Wear comfortable, good-quality walking or running shoes and appropriate clothing. Do not use the unit with bare feet, sandals, socks or stockings.
6. Always examine your unit before using to ensure all parts are in working order.
7. Allow the unit to fully stop before dismounting.
8. Pets should never be allowed near the unit.
9. Do not leave children unsupervised near or on the unit.
10. Never operate the unit where oxygen is being administered, or where aerosol products are being used.
11. Never insert any object or body parts into any opening.
12. For safety and to prevent damage to your unit, no more than one person should use the unit at a time.
13. Always unplug the unit before cleaning and/or servicing. Service to your unit should only be performed by an authorized service representative, unless authorized and/or instructed by the manufacturer.
14. Failure to follow these instructions will void the unit warranty.

# Before You Start

Thank you for purchasing the **Alliance A7e Elliptical!** This quality product you have chosen was designed to meet your needs for cardiovascular exercise. Before you start, please read the Owner's Manual and become familiar with the operation of your new unit.

**Remember to take the time to perform the stretching exercises provided to avoid injury.**

If you are taking medication, consult your physician to see if the medication will affect your exercise heart rate.

If you have heart problems, you are not active, and/or are over the age of 35 years, do not use the pre-set programs or start an exercise program without first contacting and receiving approval from your physician.

To avoid the risk of electrical shock, always keep the console dry. Do not spill liquids on the console. Keys Fitness recommends a sealed water bottle for beverages consumed while using the unit.

**Please review the following drawing below to familiarize yourself with the listed parts.**

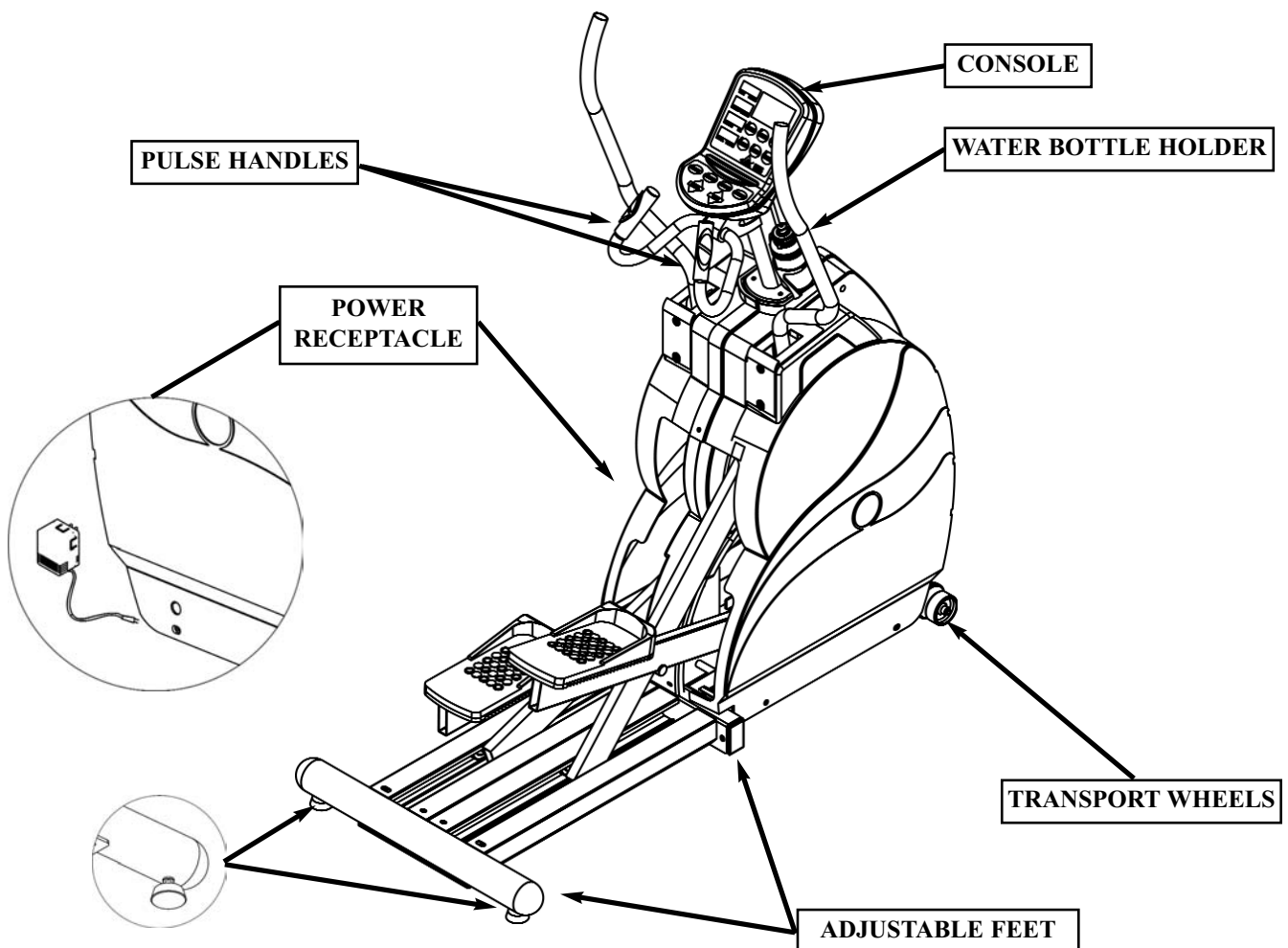

## INSTRUCTIONS FOR ASSEMBLY:

Unpack the box in a clear area. Check to make sure all components are present and in good condition. Do not dispose of the packing material until the assembly is completed. Tools have been provided for you to use when assembling this product.

### Step 1

- A) Attach the Foot Tube to the Plate and secure in place using three 3/8\*20mm Hex Bolts and 3 Large Washers.
- B) Secure the Foot Tube to the Rails using four M8\*15mm Button Screws and four Small Washers.

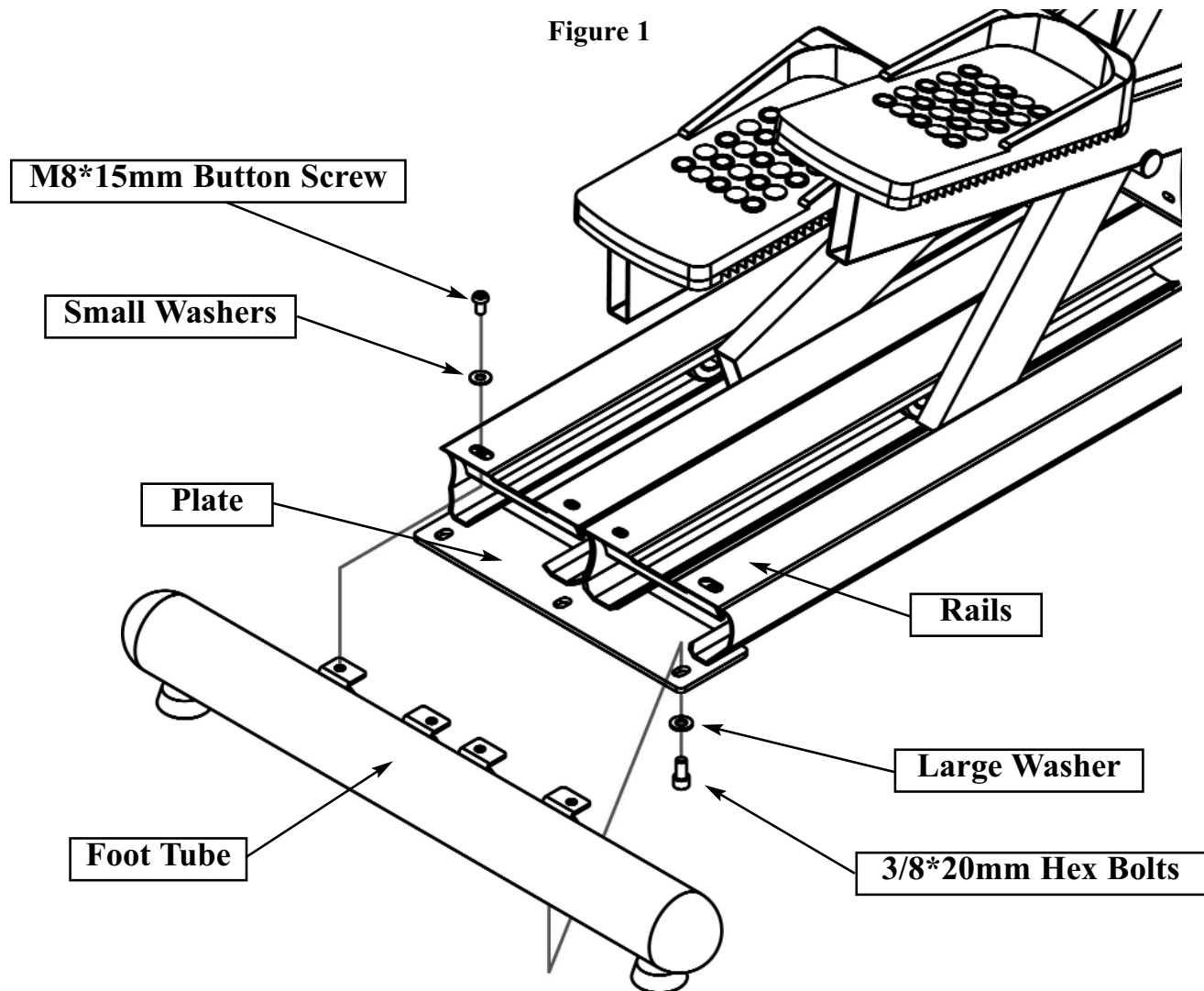

# Assembly

\* Short screw will come installed in unit, it must be removed before this assembly step begins. See Figure 2\*

## Step 2

- A) Insert Left Handlebar into the opening at the top of the left side on the Main Frame. Secure to the Pivot Arm using a Small Washer and a M8\*45mm Hex Bolt.
  - B) Slide two of the Cover Plates over the holes for the Short Screws.
  - C) Attach the Small Cover and secure in place using two Short Screws.
  - B) Slide a Grommet down the Left Handlebar and snap it onto the Main Frame.
- Note: Make sure the Grommet is facing down as shown.*
- D) Repeat A, B, and C to complete the right side.

Figure 2

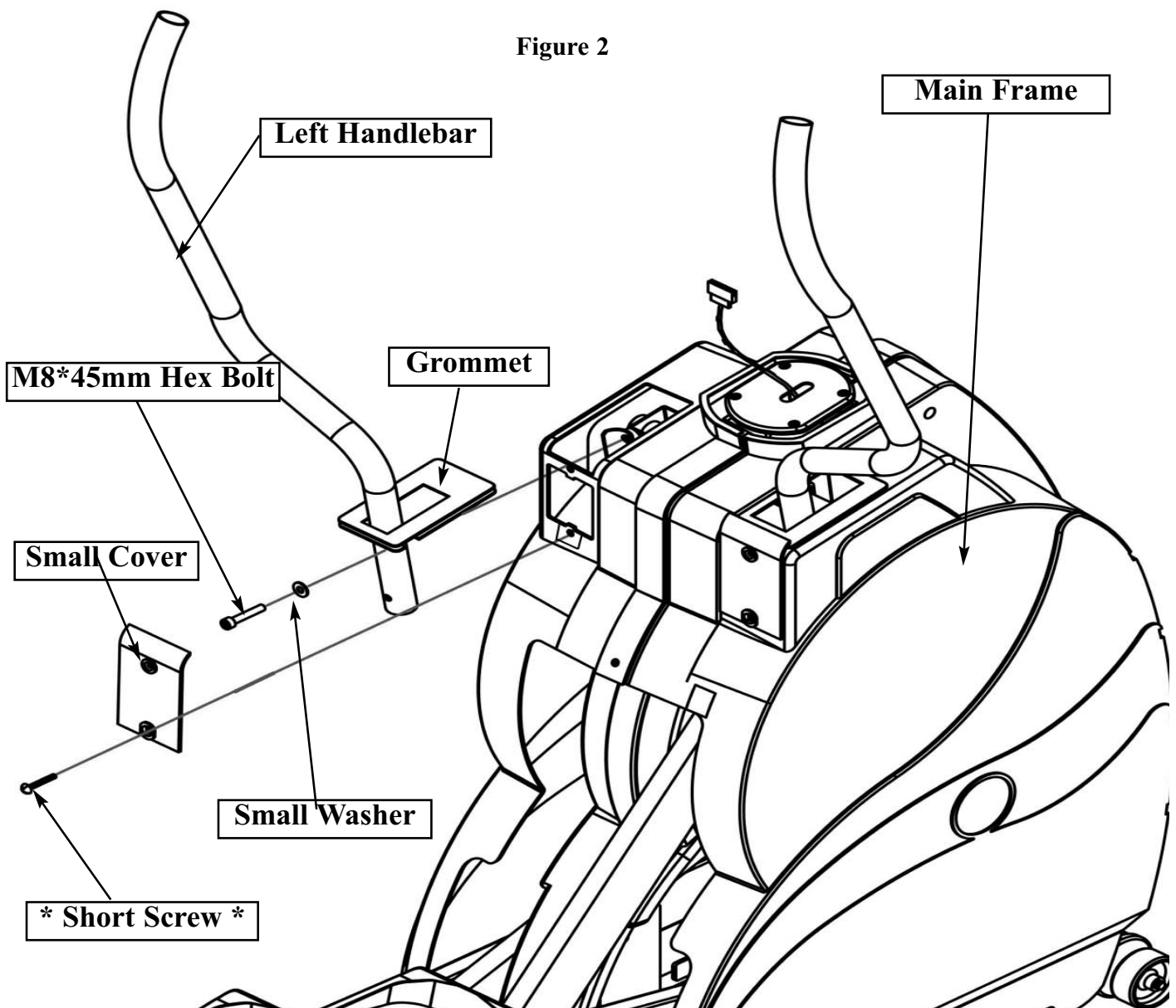

# Assembly

## Step 3

A) Plug the Upper Console Cable, the two Pulse Wires, and the Grounding Wire into the back of the Console. See **Figure 3a**

B) Secure the Console to the Console Tube and secure in place using four M5\*12mm Screws and four Small Washers.

*Note: Make sure not to pinch the wire when installing the console.*

C) Attach the Bottle Holder to the Console Tube using two Screws.

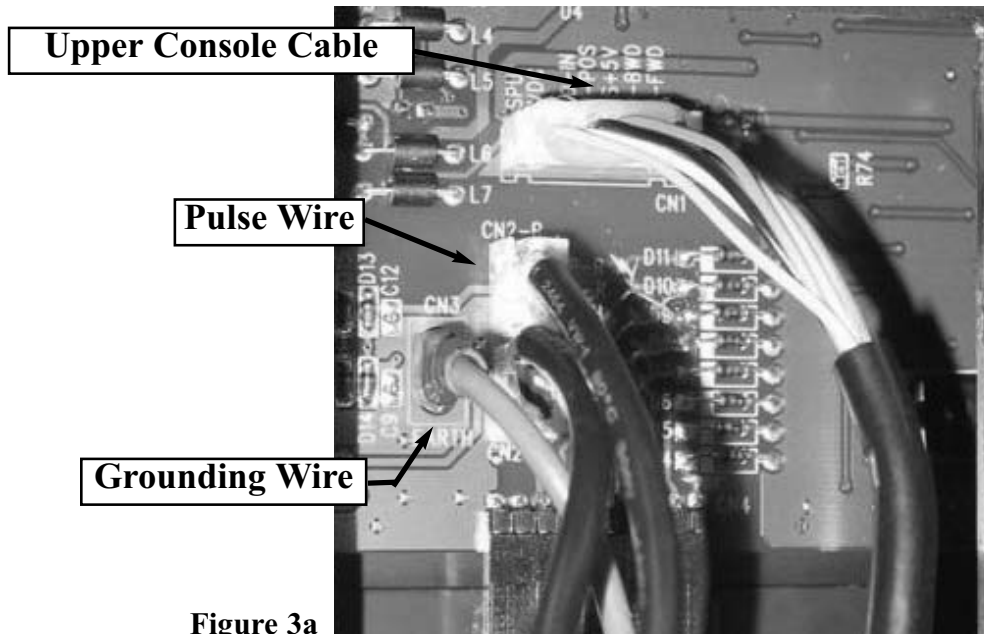

Figure 3a

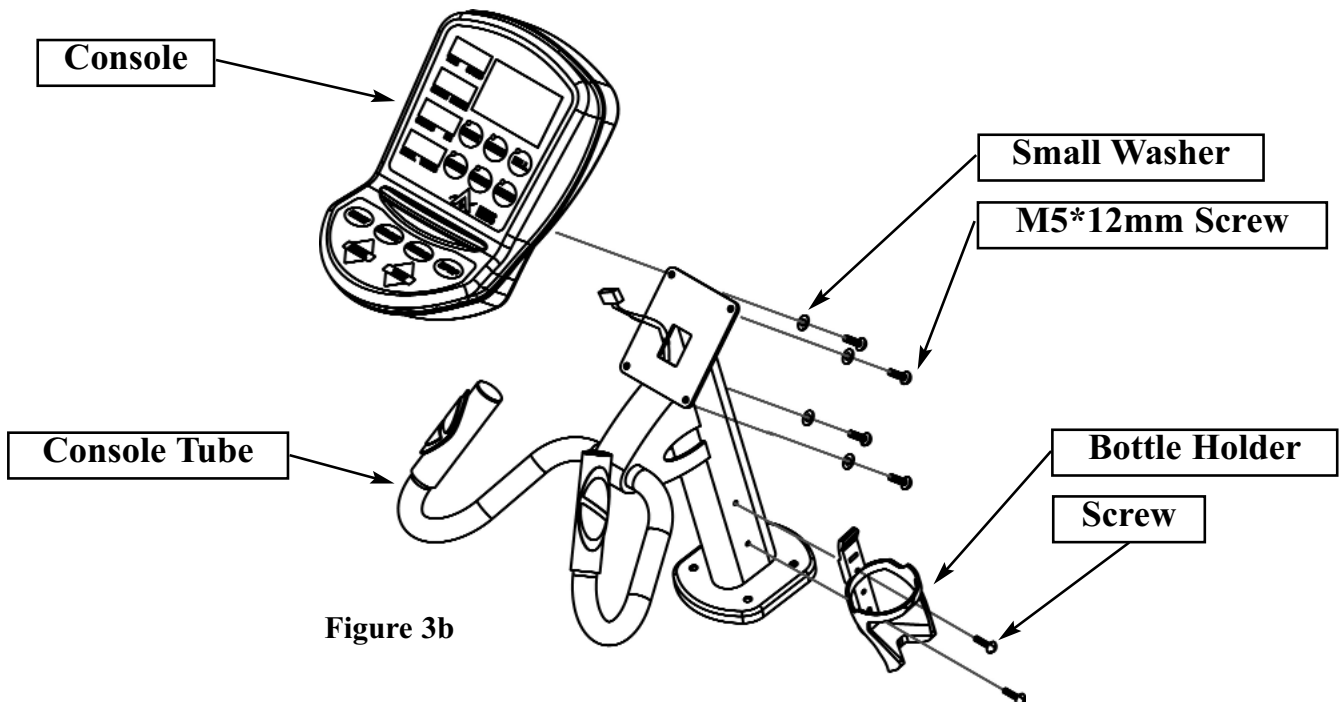
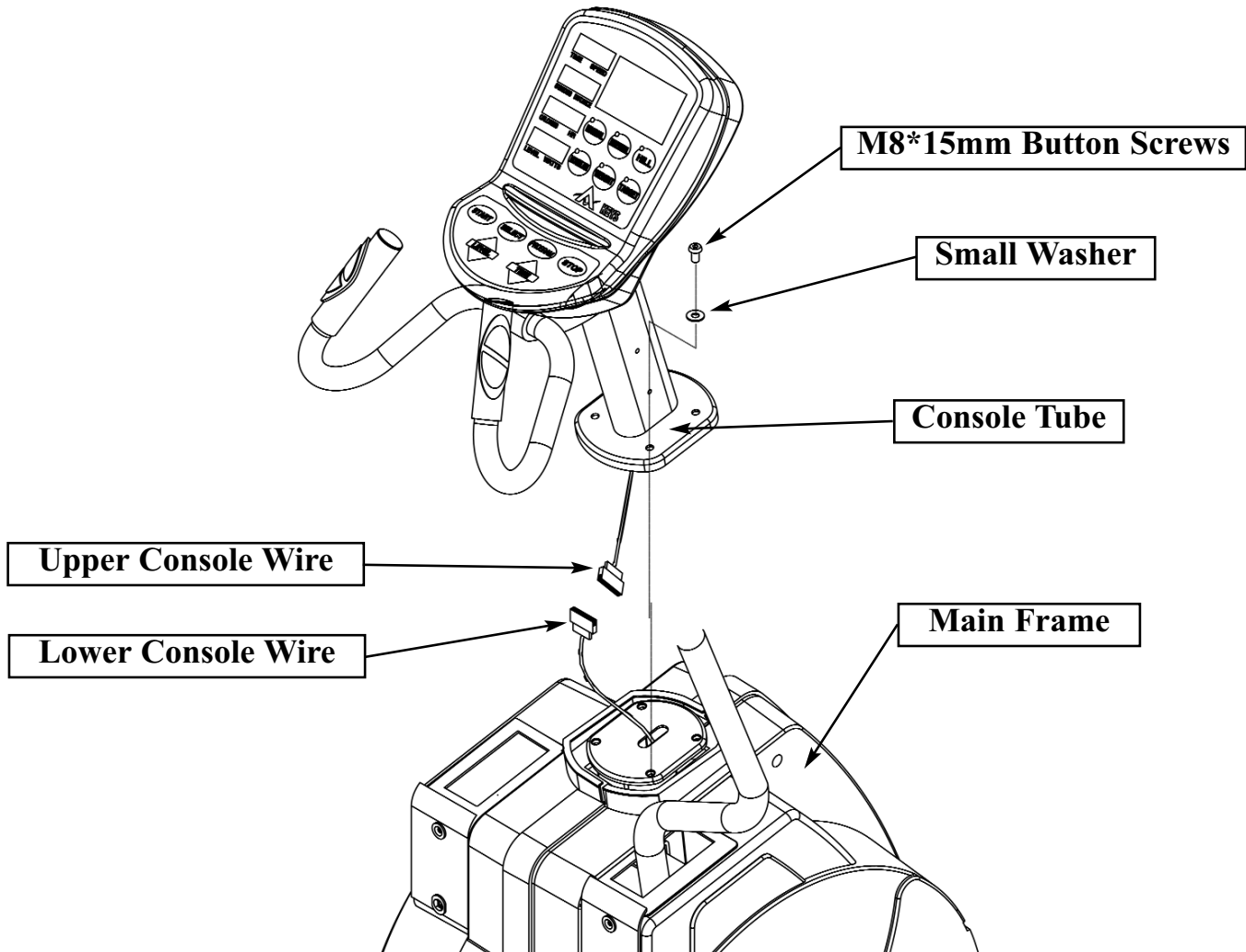

Figure 3b

## Step 4

- A) Plug the Upper Console Wire into the Lower Console Wire and slide the excess cable into the Main Frame as you lower the Console Tube down.
- B) Secure the Console Tube to the Main Frame using four Small Washers and four M8\*15mm Button Screws.

Figure 4



**Congratulations!**

**You have completed the assembly of your new Alliance A7e Elliptical!.**



## Step 5:

- A) Locate wheel kit and take out of box. Wheel kit will already include one Bolt (2D1E), two Washers (0J4J), one Wheel (015W) and one Nut (0KMV). Tighten Nut if needed.
- B) Attach wheel kit to the front of the frame. Tighten Bolt on the wheel kit.

**Note:** *You will need a 17 mm wrench in order to complete this step. Wrench is provided.*

**Figure 5**

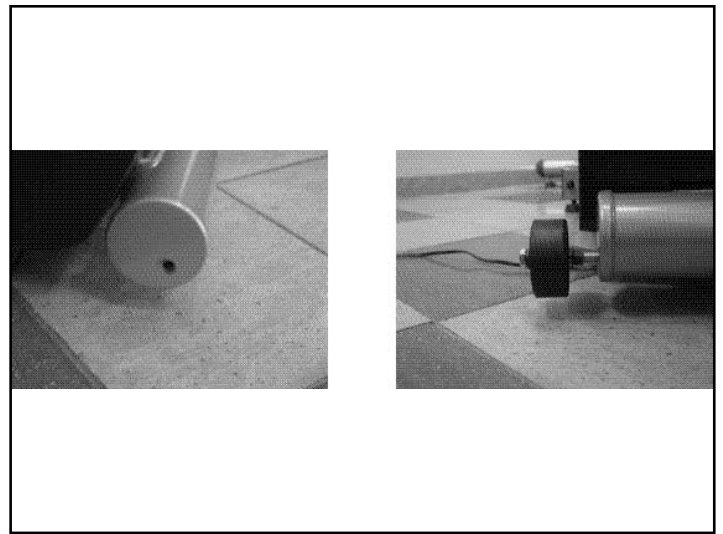
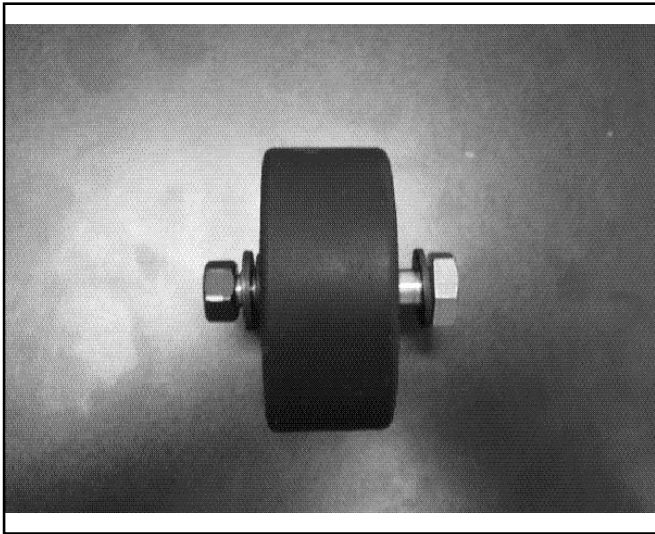

**Congratulations!**

**You have completed the assembly of your new EVOLUTION Elliptical!.**

# Console Instructions

## Display Function

- Data Window - TIME, SPEED, STRIDES, DISTANCE, CALORIES, PULSE, LEVEL, WATTS
- Profile Window - Workout program profile and message.
- Program Indicator - Indicate which program you are currently using.
- Auto Scan Indicator - When this is lit, the DATA WINDOWS will automatically switch which data is currently being displayed.

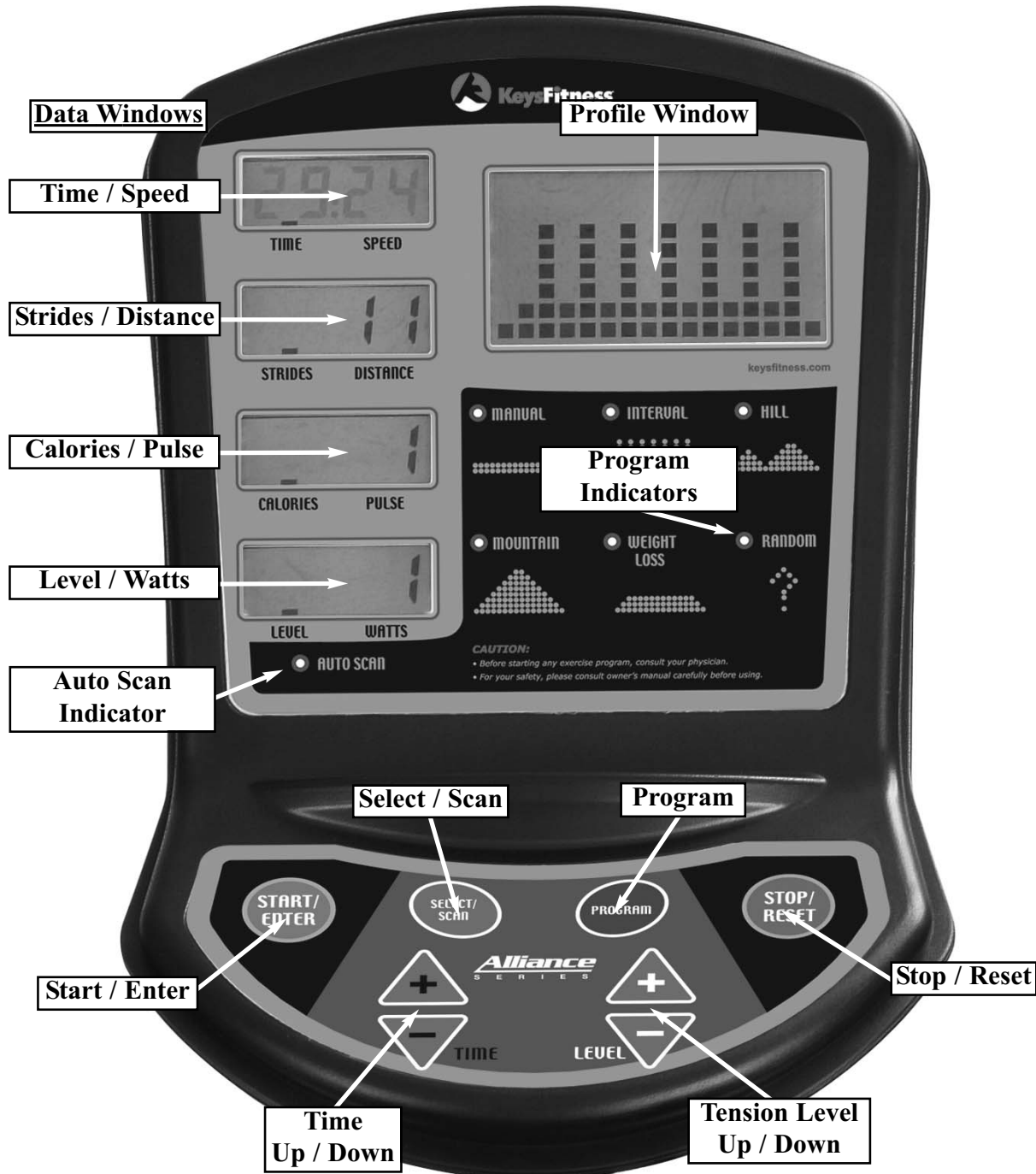

# Console Instructions

## Starting the Console:

- Plug in the power supply to power on the console.
- Press START / ENTER key to go to the Quick Start Mode.
- Press LEVEL UP and LEVEL DOWN for 2 sec. to go to the Service Mode.
- Press TIME UP and TIME DOWN for 2 sec. to go to the Metric Unit Setting Mode.
- Press the PROGRAM key to go to the Programming Mode.
- After completing the program settings, press the START / ENTER to start the workout.

## Stopping the Console:

- The console will stop when the time counts down to zero.
- Pressing the STOP / RESET key will stop the console time.
- When you stop pedaling unit for 5 seconds the console will go into pause mode.

## How to Reset the Console:

- To reset entry data during the programming mode, press STOP / RESET key will clear the entry to its default.
- To reset console to the programming mode in the middle of a program, press STOP / RESET for 2 seconds during pause mode.

## Workout Summary:

- Once the program time has counted down to zero, the console will display all the last calculations for 5 minutes presented as a workout summary. The workout summary will be terminated and reset to its defaults if any key is pressed during the 5 minutes.

## Key Description:

**START / ENTER** - Press **START / ENTER** to start time counting or to confirm your setting while programming the console.

**SELECT / SCAN** - Press **SELECT / SCAN** to swap the data window displays or press and hold it for 2 seconds to alternate the displays automatically in 4 second intervals. The **AUTO SCAN** indicator will be lit when the it is automatically shifting the console displays.

**PROGRAM** -- Press **PROGRAM** to select the workout program you choose. The **PROGRAM INDICATOR** will be lit near the program you choose.

**STOP / RESET** -- Press **STOP / RESET** to stop the time from counting or hold it for 2 seconds to reset your program time and the workout data to zero.

**TIME UP / DOWN** -- Use the **TIME UP / DOWN** to adjust the amount of time you wish to workout. The time range is from 0:00 to 99:59.

**LEVEL UP / DOWN** -- Use the **LEVEL UP / DOWN** to adjust the workout resistance. The resistance range is from 1 to 16, sixteen being the hardest.

## Programming Mode:

- 1) Use **TIME UP / DOWN** to enter the amount of time you wish to workout. The manual profile will appear on the **PROFILE WINDOW** and the setting time will be shown on the **TIME WINDOW**.
- 2) Press **START / ENTER** to confirm the workout time.
- 3) Use **LEVEL UP / DOWN** to enter the user weight. The message “LB” or “KG” will appear on the **PROFILE WINDOW** and the setting weight will be shown on the **TIME WINDOW**.
- 4) Press **START / ENTER** to confirm the user weight.
- 5) Use **PROGRAM** key to select which workout program you intend to use.
- 6) Press **START / ENTER** and the console will start with the selected workout program and the parameters you entered.

## Quick Start Mode:

- 1) Press the **START / ENTER** key only. The workout starts with the **MANUAL** program and has a 30 minute default program time.

## Using Running Mode:

- 1) The console will display and update calculated workout data on each of the **DATA WINDOWS**.
- 2) The console will continue counting the program time until it has reached zero.
- 3) Use **LEVEL UP / DOWN** to adjust the workout resistance levels during the workout.
- 4) Use **SELECT / SCAN** to change the data that is being displayed in the windows or press and hold **SELECT / SCAN** to auto scan the displays every 4 seconds.
- 5) You can change the workout program by pressing the **PROGRAM** key. Once the program is selected it will begin at the beginning column but workout data windows will continue from where they left off.

## Sleeping Mode:

- The console will go into Sleeping Mode and shut off the display if there is no speed signal or key pressed for 3 minutes.
- Sleeping Mode will end if any key is press or pedaling begins.

## Console Service Mode:

- Display Scroll Testing will show on the PROFILE WINDOW and "0"... "9", "A"... "F" on the DATA WINDOW, press any key to pass the testing.
- Keypad Testing will show the key button test results in the PROFILE WINDOW.
- Press and hold STOP / RESET key for 2 seconds to pass all the testing.

## Metric Unit Setting Mode:

- Press and hold TIME UP and TIME DOWN for 2 seconds to set the mode.
- Press LEVEL UP or LEVEL DOWN to select the mode you want..
- Press START/ENTER to save the setting.
- Press and hold STOP/RESET for 2 seconds to return to idle mode.

## Error Message:

- The TIME window will show an "Err1" message whenever the brake motor was unable to move to its target position within 2 seconds of powering on. If this happens the console will immediately disable any further key operations until the motor error disappears.
- Turn the console power off and then on again to see the error message will disappear. If the error message remains call Keys Fitness Technical Service for more information.

# Monitoring Your Heart Rate

## *Monitoring Your Heart Rate*

To obtain the greatest cardiovascular benefits from your exercise workout, it is important to work within your target heart rate zone. The American Heart Association (AHA) defines this target as 60%-75% percent of your maximum heart rate.

Your maximum heart rate may be roughly calculated by subtracting your age from 220. Your maximum heart rate and aerobic capacity naturally decreases as you age. This may vary from one person to another, but use this number to find your approximate effective target zone. For example, the maximum heart rate for an average 40 year-old is 180 bpm. The target heart rate zone is 60%-75% of 180 or 108-135 bpm. See *Fitness Safety* below.

Before beginning your workout, check your normal resting heart rate. Place your fingers lightly against your neck, or against your wrist over the main artery. After finding your pulse, count the number of beats in 10 seconds. Multiply the number of beats by six to determine your pulse rate per minute. We recommend taking your heart rate at these times; at rest, after warming up, during your workout and two minutes into your cool down, to accurately track your progress as it relates to better fitness.

During your first several months of exercising, the AHA recommends aiming for the lower part of the target heart rate zone-60%, then gradually progressing up to 75%.

According to the AHA, exercising above 75% of your maximum heart rate may be too strenuous unless you are in top physical condition. Exercising below 60% of your maximum will result in minimal cardiovascular conditioning.

Check your pulse recovery rate – If your pulse is over 100 bpm five minutes after you stop exercising, or if it's higher than normal the morning after exercising, your exertion may have been too strenuous for your current fitness level. Rest and reduce the intensity next time.

**Fitness Safety** *The target heart rate chart indicates average rate zones for different ages. A variety of different factors (including medication, emotional state, temperature and other conditions) can affect the target heart rate zone that is best for you. Your physician or health care professional can help you determine the exercise intensity that is appropriate for your age and condition.*

(MHR) = Maximum Heart Rate

(THR) = Target Heart Rate

$220 - \text{age} = \text{maximum heart rate (MHR)}$

$\text{MHR} \times .60 = 60\% \text{ of your maximum heart rate.}$

$\text{MHR} \times .75 = 75\% \text{ of your maximum heart rate.}$

For example, if you are 30 years old, your calculations will be as follows:

$220 - 30 = 190$

$190 \times .60 = 114 \text{ (low end or 60\% of MHR)}$

$190 \times .75 = 142 \text{ (high end or 75\% of MHR)}$

30 year-old (THR) Target Heart Rate would be 114-142

See Heart Rate Table (on next page) for additional calculations.

## TARGET HEART RATE ZONE

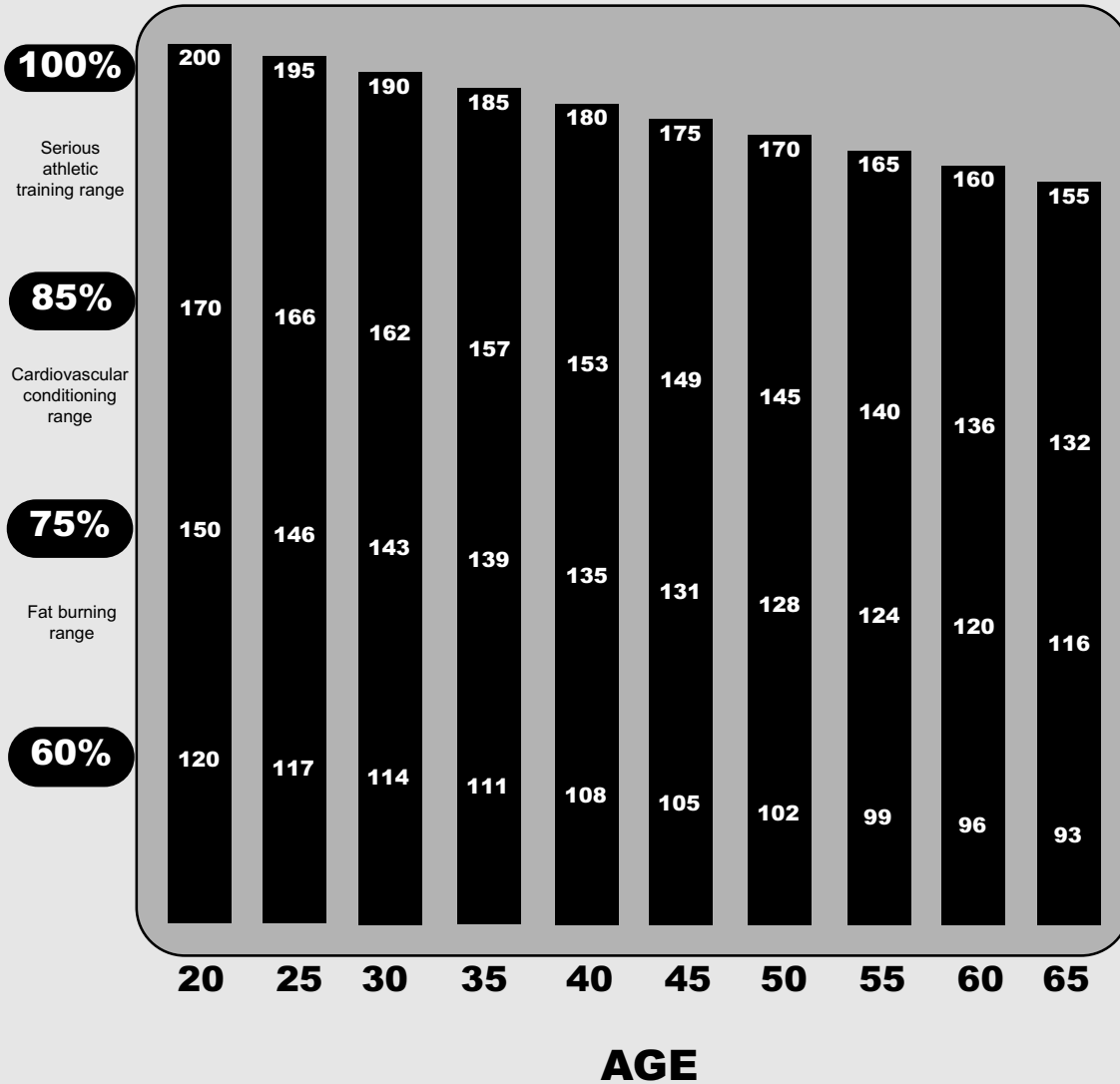

## Moving Instructions

**Alliance**  
S E R I E S

**CAUTION!** TO REDUCE THE POSSIBILITY OF INJURY WHILE LIFTING, BEND YOUR LEGS AND KEEP YOUR BACK STRAIGHT. AS YOU LEAN THE UNIT, LIFT USING YOUR LEGS, NOT YOUR BACK.

Reach down and grab the rear Foot Tube assembly with both hands. Next, carefully tilt the unit up until it rolls freely on the transport wheels. Using extreme caution, move the unit to the desired location. To set the unit down, carefully lower unit onto Foot Tube assembly in a resting position. Do not attempt to move the unit over an uneven or rough surface.





## EXERCISE GUIDELINES

**WARNING!** Before beginning this or any exercise program, you should consult your physician. This is especially important for individuals over the age of 35 or individuals with pre-existing health problems.

Warming up prepares the body for the exercise by increasing circulation, supplying more oxygen to the muscles and raising body temperature. Begin each workout with 5 to 10 minutes of stretching and light exercise to warm up. The photos on this page show several forms of basic stretching you may perform before your workouts. In order to achieve an adequate warm-up, perform each stretch three times.

### TOE TOUCH STRETCH

Stand bending your knees slightly and slowly bend forward from your hips. Allow your back and shoulders to relax as you reach down toward your toes as far as possible. Hold for 15 counts, then relax. This will stretch your hamstrings, back of knees, and back.



### HAMSTRING STRETCH

Sit with one leg extended. Bring the sole of the opposite foot toward you and rest it against the inner thigh of your extended leg. Reach toward your toes as far as possible. Hold for 15 counts, then relax. This will stretch your hamstrings, lower back, and groin.

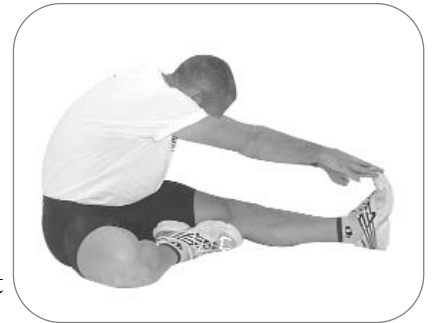

### CALF/ACHILLES STRETCH

With one leg in front of the other, reach forward and place your hands against a wall. Keep your back leg straight and your back foot flat on the floor. Bend your front leg, lean forward and move your hips toward the wall. Hold for 15 counts, then relax. To cause further stretching of the Achilles tendon, bend your back leg as well. This will stretch your calves, Achilles tendons, and ankles.



### QUADRICEPS STRETCH

With one hand against a wall for balance, reach back and grasp one foot with your other hand. Bring your heel as close to your buttocks as possible. Hold for 15 counts, then relax. This will stretch your quadriceps and hip muscles.

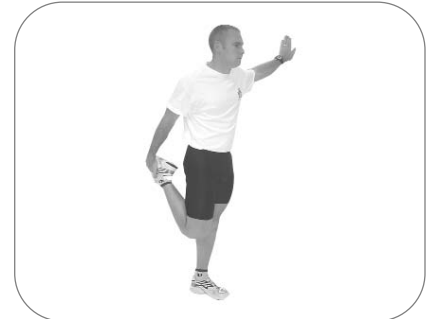

### INNER THIGH STRETCH

Sit with the soles of your feet together and your knees outward. Pull your feet toward your groin area as far as possible. Hold for 15 counts, then relax. This will stretch your quadriceps and hip muscles.

# Parts List



## A7e Parts List Rev D

REF #	PART #	DESCRIPTION	QTY	REF #	PART #	DESCRIPTION	QTY
014X	306-00284	END CAP, 45MMX75MM RECTANGULAR END CAP	2	0K94	302-00115	CR. RE. TRUSS HD. TAPPING SCREW M5*12-16	4
014Y	310-00114	LEVELER	3	0K98	302-00116	CR. RE. TRUSS HD. TAPPING SCREW M3.5*18-	4
0157	306-00282	WHEEL ASSEMBLY	4	0KCB	302-00117	CR. RE. TRUSS HD. TAPPING SCREW M5*12-25	2
0158	302-00095	FLAT WASHER 8.5*32MM	2	0KDK	302-00111	CR. RE. PAN HD. SCREW M5*0.8-16MM	2
015A	302-00097	SHAFT BUSHING, OD 35MM	4	0KFE	302-00139	WASHER, OD6MM	1
015C	323-00142	PEDAL LEVER	1	0KFZ	302-00112	CR. RE. PAN HD. SCREW M5*0.8-125MM	1
015D	306-00293	STRAIN RELIEF	2	0KMV	302-01170	NUT, HEX HEAD, M10*1.5	2
015E	330-00039	CENTER SHAFT	2	0KMY	302-00122	HEX. NUT M8*1.25 T=6.5MM	5
015H	319-00003	LINKAGE	2	0KN1	302-00123	HEX. NUT M5*0.8 T=5MM	1
015N	302-00146	SPRING, OD17.8MMX108MM	1	0KNE	302-00124	HEX. NUT M6*1.0 T=5MM	2
015P	319-00002	ADJUSTMENT PLATE	2	0KQY	302-00135	LOCK NUT M8*1.25 T=8MM	2
015Q	302-00136	SCREW, M6-30MM (L)	2	0KR9	302-00136	SCREW, M6-30MM (L)	4
015R	311-00040	EDDY CURRENT BRAKE	1	0KRK	302-00144	U-TYPE NUT M5-12MM	4
015W	306-00291	TRANSPORTATION WHEEL, A7E	2	0KRV	302-00121	HEX. HD. NUT 3/8*26T	2
015Y	302-00096	SHAFT BUSHING, OD26MM	4	0ZLT	302-00143	WRENCH HEX. 5/16"-3 3/4"	1
0163	311-00038	POLY V-BELT PULLEY	1	10LU	310-00126	LEVELER (REAR)	2
0165	319-00001	IDLER TENSIONED PLATE	1	2195	310-00113	FOAM GRIP,OD34MMX510MM LENGTH	2
0168	323-00140	PEDAL TUBE	1	21CV	310-00118	WATER BOTTLE CAGE	1
016C	306-00285	END CAP, 25.2MMX75.2 RECTANGULAR A7E,600	2	21EU	306-00376	CENTER CASE 600E A7E	1
2D1E	302-01171	BOLT, HEX HEAD, M10*55MM	2	21F1	306-00292	PLATE COVER	2
016P	330-00041	CRANK ARM	2	21F2	305-00094	COVER, LEFT W/ LOGO, A7E	1
016U	330-00040	CENTER SHAFT ASSEMBLY	1	21F3	305-00095	COVER, RIGHT W/LOGO, A7E	1
017X	306-00290	RUBBER COVER	2	21H4	314-00009	WARNING LABEL	1
018A	314-00004	600E INSTRUCTION LABEL	1	21HN	310-00115	BRAKE CABLE	1
018D	302-00098	FLAT WASHER 16*20-0.3MM	4	21MY	302-00106	FLAT WASHER 29*24*0.3MM	4
018E	302-00140	WRENCH, M8 HEX HD, L=108MM	1	21R6	313-00071	TRANSFORMER 600E	1
01HU	313-00072	POWER SOCKET	1	23A1	307-00055	MOTOR 600E	1
01J8	313-00069	REED SWITCH	1	27FK	313-00067	CONTACT HR SENSOR	2
0HV4	331-00035	BALL BEARING, 6203LU, 600E	4	280K	313-00068	HAND PULSE HARNESS	2
0HVP	331-00036	BALL BEARING 6004ZZ ( 600E)	2	2872	313-00065	GROUNDING CABLE	1
0HWC	331-00037	BALL BEARING 6005Z ( 600E)	2	28JH	310-00116	FOAM GRIP,OD31MMX125MM T=3MM	2
0J3Q	302-00141	WRENCH HEX. 5-70MM	1	28JV	323-00153	RAIL ASSEMBLY	1
0J3R	302-00142	WRENCH HEX. 6-83MM	1	28JY	323-00145	LEFT HANDLEBAR ASSEMBLY	1
0J4D	302-00099	FLAT WASHER 5*10-1MM	1	28JZ	323-00146	RIGHT MOVING HANDLE BAR ASSEMBLY	1
0J4E	302-00100	FLAT WASHER 6*13-1MM	2	28K0	323-00154	REAR STABILIZER ASSEMBLY	1
0J4J	302-00101	FLAT WASHER 10*20-2MM	3	28K5	323-00143	CONSOLE MAST	1
0J4P	302-00102	FLAT WASHER 8*16-1.4MM	4	28K6	323-00152	LEFT PIVOT ARM	1
0J57	302-00103	FLAT WASHER 8.2*19-1.4MM	4	28K7	323-00151	RIGHT PIVOT ARM	1
0J5H	302-00138	WASHER 5.2*12-1.0MM	4	28R6	323-00308	FRAME, REVISED FOR NEW TRANS WHEEL	1
0J6C	302-00101	FLAT WASHER 10*20-2MM	4	28RP	313-00066	CONSOLE HARNESS	1
0J7F	302-00105	FLAT WASHER 5/16*7/8-5/64	4	28RQ	313-00070	WIRE HARNESS MAIN	1
0JAG	302-00137	SCREW, M5-6MM	1	28T4	306-00287	END CAP, OD31.5MM ROUND, A7E	2
0JED	302-00108	C-RING A-16	2	28T5	306-00288	END CAP, OD76MM ROUND, A7E, 600E	2
0JEG	302-00109	C-RING A-20	1	28VS	310-00119	WATER BOTTLE	1
0JEH	302-00110	C-RING A-24	2	28VT	310-00120	WATER BOTTLE ASSEMBLY	1
0JGQ	302-00147	PARALLEL KEY	2	28ZR	323-00150	LEFT PIVOT ARM ASSEMBLY	1
0JLE	304-00012	BELT, POLY V BELT A7E	1	28ZS	323-00149	RIGHT PIVOT ARM ASSEMBLY	1
0JUX	302-00125	HEX. SOC. HD. CAP BOLT M8*1.25-30MM	4	28ZT	323-00147	LINKAGE ASSEMBLY	2
0JV0	302-00126	HEX. SOC. HD. CAP BOLT M8*1.25-45MM	4	28ZU	323-00148	PEDAL LEVER ASSEMBLY	1
0JV2	302-00127	HEX. SOC. HD. CAP BOLT M8*1.25-60MM	2	29Q7	306-00289	PEDAL	1
0JWJ	302-00128	HEX. SOC. HD. CAP BOLT 3/8"-16UNC-3/4inc	3	29Q8	306-00289	PEDAL	1
0JWP	302-00129	HEX. SOC. HD. CAP BOLT 3/8*16UNC-2INCH	2	2908	323-00141	PEDAL TUBE ASSEMBLY	1
0JWQ	302-00130	HEX. SOC. HD. CAP BOLT 3/8*16UNC-2"	2	2909	311-00039	IDLER PULLEY ASSEMBLY, 600e/A7e	1
0JWR	302-00120	HEX. HD. BOLT 3/8*16-3"	2	290A	313-00073	REED SWITCH ASSEMBLY	1
0JX8	302-00131	HEX. SOC. SET SCREW M6*1.0-8MM	4	290B	311-00041	POLY V-BELT PULLEY ASSEMBLY	1
0K01	302-00132	HEX. SOC. TRUSS HD. SCREW M8*1.25-15 MM	4	29ZM	307-00062	CONSOLE, A7e	1
0K03	302-00133	HEX. SOC. TRUSS HD. SCREW M8*1.25-15MM	4	29ZT	314-00011	MEDALLION KEYS	2
0K09	302-00134	HEX. SOC. TRUSS HD. SCREW M8*1.25-12MM	2	29ZU	314-00013	SHROUD LABEL (LEFT) A7E	1
0K37	302-00118	CR.RE. PAN HD. SCREW & WASHER M5*0.8-16mm	1	29ZV	314-00012	SHROUD LABEL (RIGHT) A7E	1
0K4A	302-00119	CR.RE. PAN HD. SCREW & WASHER M5*0.8-20	2	29ZW	314-00014	A7E LABEL AT SHROUD	2
0K4R	302-00145	CR.-RE. TRUSS HD. SCREW M5*0.8-12MM	4	2A00	314-00015	ALLIANCE SERIAL LABEL	1
0K7H	302-00113	CR. RE. ROUND WASHER HD. SCREW M5*0.8-25	2	#	315-00009	OWNER'S MANUAL A7e	1
0K7N	302-00114	CR. RE. ROUND WASHER HD. SCREW M6*1.0-30	8				

# Exploded View

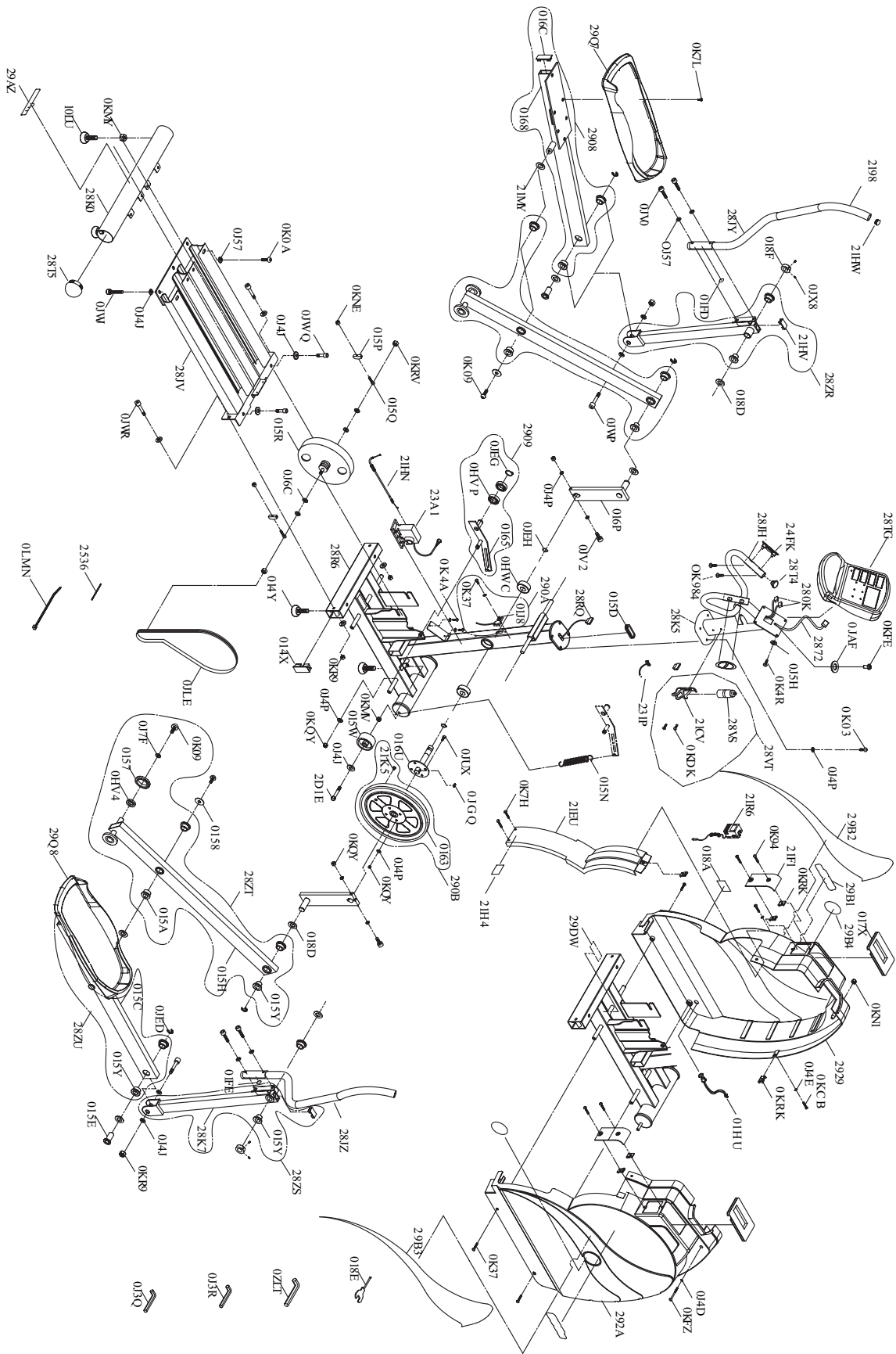

# Warranty Information



## KEYS FITNESS PRODUCTS, LP - LIMITED WARRANTY

**PRODUCT:** Alliance A7e Elliptical

**HOME USE WARRANTY:**

Parts: 3 Years, Electronics: 2 Years, Labor: 1 Year

**LIGHT INSTITUTIONAL:**

Parts: 2 Years, Electronics: 2 Years, Labor: 1 Year

This Limited Warranty applies in the United States and Canada to products manufactured or distributed by Keys Fitness Products, LP ("Keys") under the KEYS brand name. The warranty period to the original purchaser is listed above in the table.

Keys warrants that the Product you have purchased for use from Keys or from an authorized Keys reseller is free from defects in materials or workmanship under normal use during the warranty period. Your sales receipt, showing the date of purchase of the Product, is your proof of purchase. This warranty only extends to you, the original purchaser. It is not transferable to anyone who subsequently purchases the Product from you. It excludes expendable parts (wear items). Wear items pertain to components that might need to be replaced due to normal wear and tear. These items vary per product but will include computer overlays, pedal straps, rope cords, seats, grips, chains, bottom bracket assemblies, pads, upholstery, pulleys, bearings, etc. Please contact a Keys Fitness customer service representative for specifics on wear items. This Limited Warranty becomes VALID ONLY if the product is purchased through a Keys Fitness authorized dealer unless otherwise authorized by Keys Fitness in writing.

During the warranty period Keys will repair or replace (at Keys' option) the product if it becomes defective, malfunctions, or otherwise fails to conform with this Limited Warranty under normal use. In repairing the Product, Keys may replace defective parts, or at the option of Keys, serviceable used parts that are equivalent to new parts in performance. All exchanged parts and Products replaced under this warranty will become the property of Keys. Keys reserves the right to change manufacturers of any part to cover any existing warranty.

This warranty DOES NOT COVER shipping charges, export taxes, custom duties and taxes, or any other charges associated with transportation of the parts or Product.

To obtain warranty service, you must contact a Keys authorized retailer, service technician or Keys Fitness at our phone numbers located in this manual. Any parts determined to be defective must be returned to Keys to obtain warranty service. You must prepay any shipping charges, export taxes, custom duties and taxes, or any other charges associated with transportation of the parts or Product. In addition, you are responsible for insuring any parts or Product shipped or returned. You assume the risk of loss during shipment. You must present Keys with proof-of-purchase documents (including the date of purchase). Any evidence of alteration, erasing or forgery of proof-of-purchase documents will be cause to void this Limited Warranty.

This warranty does not extend to any product not purchased from Keys or from an authorized Keys reseller. This Limited Warranty does not extend to any Product that has been damaged or rendered defective; (a) as a result of accident, misuse, or abuse; (b) by the use of parts not manufactured or sold by Keys; (c) by modification of the Product or normal wear and tear; (d) operation on incorrect power supplies; or (e) as a result of service by anyone other than Keys, or an authorized Keys warranty service provider. Product on which the serial number has been defaced or removed is not eligible for warranty service. Should any Product submitted for warranty service be found ineligible, an estimate of repair cost will be furnished and the repair will be made if requested by you upon Keys' receipt of payment or acceptable arrangements for payment.

EXCEPT AS EXPRESSLY SET FORTH IN THIS WARRANTY, KEYS MAKES NO OTHER WARRANTIES, EXPRESSED OR IMPLIED, INCLUDING ANY IMPLIED WARRANTIES OF MERCHANTABILITY AND FITNESS FOR A PARTICULAR PURPOSE. KEYS EXPRESSLY DISCLAIMS ALL WARRANTIES NOT STATED IN THIS LIMITED WARRANTY. ANY IMPLIED WARRANTIES THAT MAY BE IMPOSED BY LAW ARE LIMITED TO THE TERMS OF THIS LIMITED WARRANTY. NEITHER KEYS NOR ANY OF ITS AFFILIATES SHALL BE RESPONSIBLE FOR INCIDENTAL OR CONSEQUENTIAL DAMAGES. SOME STATES DO NOT ALLOW LIMITATIONS ON HOW LONG AN IMPLIED WARRANTY LASTS OR THE EXCLUSION OR LIMITATION OF INCIDENTAL OR CONSEQUENTIAL DAMAGES, SO THE ABOVE LIMITATIONS OR EXCLUSION MAY NOT APPLY TO YOU. This Limited Warranty gives you specific legal rights and you may also have other rights that may vary from state to state. This is the only express warranty applicable to Keys-branded products. Keys neither assumes nor authorizes anyone to assume for it any other express warranty.

PLEASE SEND IN THE WARRANTY CARD WITHIN TEN (10) DAYS OF PURCHASE TO REGISTER YOUR UNIT WITH KEYS FITNESS PRODUCTS, LP.

MAIL WARRANTY CARD TO:

KEYS FITNESS PRODUCTS, PO BOX 551239, DALLAS, TX 75355



**Customer Service**

(888) 340-0482

**Keys Fitness Products**

4009 Distribution Drive  
Suite 250  
Garland, TX 75041

[www.keysfitness.com](http://www.keysfitness.com)