

1-888-340-0482
Monday-Friday
8:30-5:30 Central Time



Keys Fitness Products, L.P.
4009 Distribution Dr.
Suite 250
Garland, Texas 75041

CardioMax

835 Recumbent

OWNER'S MANUAL

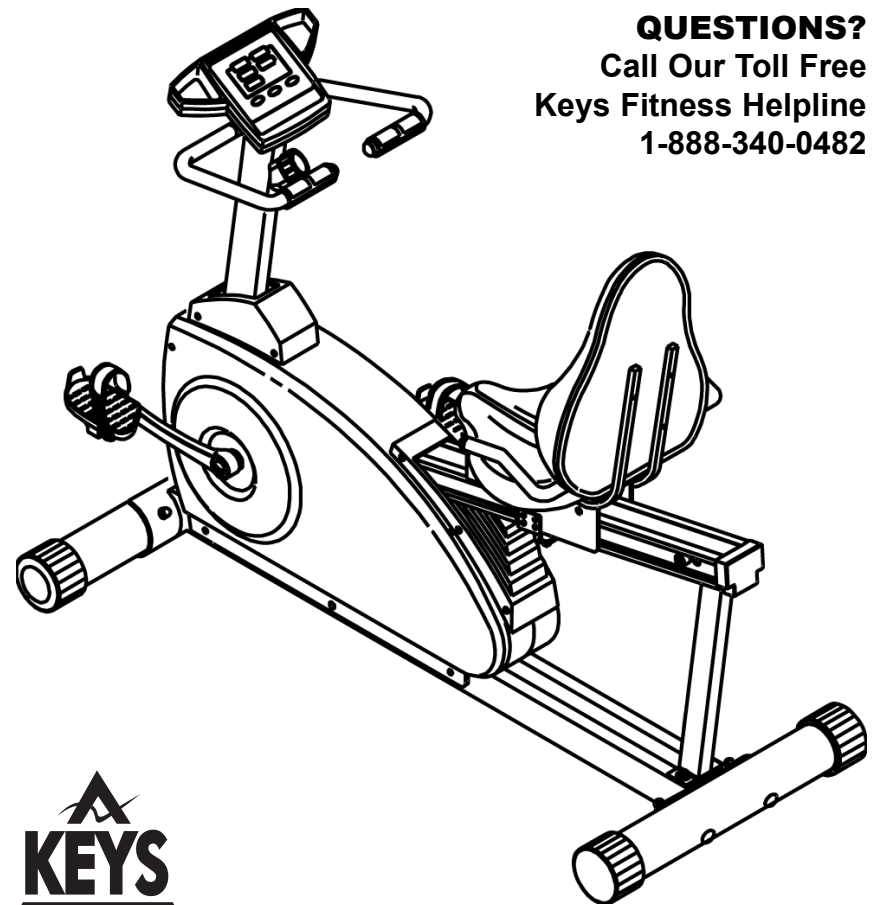

QUESTIONS?
Call Our Toll Free
Keys Fitness Helpline
1-888-340-0482



Keys Fitness Products, L.P.
P.O. Box 551239
Dallas, Texas 75355-1239

CAUTION!

Please read the precautions and instructions in this manual before using this equipment. Please save this manual for future reference.



Keys Fitness is committed to quality products that demonstrate our commitment to excellence!

**Keys Exercise Bike
Model: 835R**

Questions?

Please call if:

- you need assistance about operating your exercise bike
- parts are missing
- parts become worn or need to be replaced

**1-888-340-0482
Monday-Friday
8:30-5:30 Central Time**

When requesting information please have the following available:

- The Name
- The Model
- The Part Number
- The Description

KEYS FITNESS PRODUCTS, LP - LIMITED WARRANTY

PRODUCT: CARDIOMAX 835 RECUMBENT EXERCISE BIKE
HOME USE WARRANTY: Frame: Lifetime, Parts: 2 Years, Labor: 1 Year

This Limited Warranty applies in the United States and Canada to products manufactured or distributed by Keys Fitness Products, LP ("Keys") under the KEYS brand name. The warranty period to the original purchaser is listed above in the table.

Keys warrants that the Product you have purchased for use from Keys or from an authorized Keys reseller is free from defects in materials or workmanship under normal use during the warranty period. Your sales receipt, showing the date of purchase of the Product, is your proof of purchase. This warranty only extends to you, the original purchaser. It is not transferable to anyone who subsequently purchases the Product from you. It excludes expendable parts (wear items). Wear items pertain to components that might need to be replaced due to normal wear and tear. These items vary per product but will include computer overlays, pedal straps, rope cords, seats, grips, chains, bottom bracket assemblies, pads, upholstery, pulleys, bearings, etc. Please contact a Keys Fitness customer service representative for specifics on wear items. This Limited Warranty becomes VALID ONLY if the product is purchased through a Keys Fitness authorized dealer unless otherwise authorized by Keys Fitness in writing.

During the warranty period Keys will repair or replace (at Keys' option) the product if it becomes defective, malfunctions, or otherwise fails to conform with this Limited Warranty under normal use. In repairing the Product, Keys may replace defective parts, or at the option of Keys, serviceable used parts that are equivalent to new parts in performance. All exchanged parts and Products replaced under this warranty will become the property of Keys. Keys reserves the right to change manufacturers of any part to cover any existing warranty.

This warranty DOES NOT COVER shipping charges, export taxes, custom duties and taxes, or any other charges associated with transportation of the parts or Product.

To obtain warranty service, you must contact a Keys authorized retailer, service technician or Keys Fitness at our phone numbers located in this manual. Any parts determined to be defective must be returned to Keys to obtain warranty service. You must prepay any shipping charges, export taxes, custom duties and taxes, or any other charges associated with transportation of the parts or Product. In addition, you are responsible for insuring any parts or Product shipped or returned. You assume the risk of loss during shipment. You must present Keys with proof-of-purchase documents (including the date of purchase). Any evidence of alteration, erasing or forgery of proof-of-purchase documents will be cause to void this Limited Warranty.

This warranty does not extend to any product not purchased from Keys or from an authorized Keys reseller. This Limited Warranty does not extend to any Product that has been damaged or rendered defective; (a) as a result of accident, misuse, or abuse; (b) by the use of parts not manufactured or sold by Keys; (c) by modification of the Product or normal wear and tear; (d) operation on incorrect power supplies; or (e) as a result of service by anyone other than Keys, or an authorized Keys warranty service provider. Product on which the serial number has been defaced or removed is not eligible for warranty service. Should any Product submitted for warranty service be found ineligible, an estimate of repair cost will be furnished and the repair will be made if requested by you upon Keys' receipt of payment or acceptable arrangements for payment.

EXCEPT AS EXPRESSLY SET FORTH IN THIS WARRANTY, KEYS MAKES NO OTHER WARRANTIES, EXPRESSED OR IMPLIED, INCLUDING ANY IMPLIED WARRANTIES OF MERCHANTABILITY AND FITNESS FOR A PARTICULAR PURPOSE. KEYS EXPRESSLY DISCLAIMS ALL WARRANTIES NOT STATED IN THIS LIMITED WARRANTY. ANY IMPLIED WARRANTIES THAT MAY BE IMPOSED BY LAW ARE LIMITED TO THE TERMS OF THIS LIMITED WARRANTY. NEITHER KEYS NOR ANY OF ITS AFFILIATES SHALL BE RESPONSIBLE FOR INCIDENTAL OR CONSEQUENTIAL DAMAGES. SOME STATES DO NOT ALLOW LIMITATIONS ON HOW LONG AN IMPLIED WARRANTY LASTS OR THE EXCLUSION OR LIMITATION OF INCIDENTAL OR CONSEQUENTIAL DAMAGES, SO THE ABOVE LIMITATIONS OR EXCLUSION MAY NOT APPLY TO YOU. This Limited Warranty gives you specific legal rights and you may also have other rights that may vary from state to state. This is the only express warranty applicable to Keys-branded products. Keys neither assumes nor authorizes anyone to assume for it any other express warranty.

PLEASE SEND IN THE ATTACHED WARRANTY CARD WITHIN TEN (10) DAYS OF PURCHASE TO REGISTER YOUR UNIT WITH KEYS FITNESS PRODUCTS, LP.

MAIL WARRANTY CARD TO:
KEYS FITNESS PRODUCTS, PO BOX 551239, DALLAS, TX 75355

Before You Start

Thank you for purchasing a Keys exercise bicycle! This quality product you have chosen was designed to meet your needs for cardiovascular exercise.

Prior to assembly, remove components from the box and verify that all the listed parts were supplied. Assembly instructions are described in the following steps and illustrations.

Important Safety Information WARNING!

- 1) Before using this exercise bicycle or starting any exercise program, consult your physician. This is especially important for persons over the age of 35 and/or persons with pre-existing health problems. Keys Fitness Products LP assumes no responsibility for personal injury or property damage sustained by or through the use of this product.
- 2) To reduce the risk of electrical shock, burns, fire or other possible injuries to the user, it is important to review this manual and the following precautions before operation.

Safety Precautions and Tips









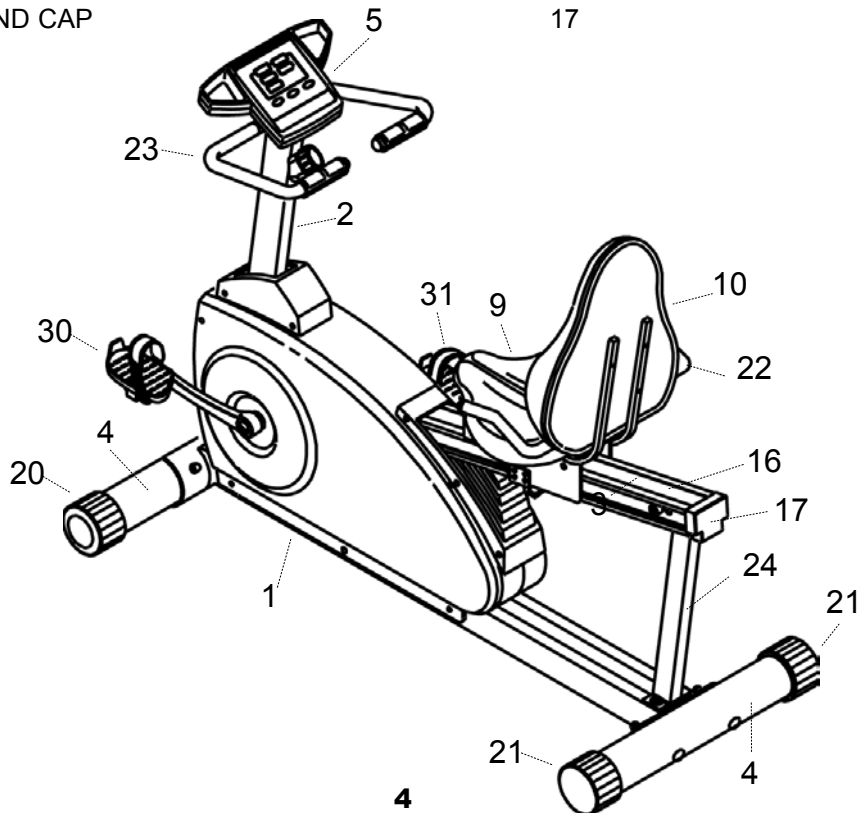



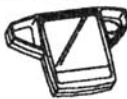











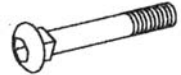
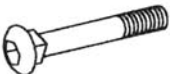

It is the owner's responsibility to ensure that all users of this exercise bike have read the Owner's Manual and are familiar with warnings and safety precautions.

- This exercise bike has a user maximum capacity of 300 pounds.
- The CardioMax Exercise bike should only be used on a level surface and is intended for indoor use only. It should not be placed in a garage, patio or near water. Keys recommends an equipment mat be placed under the bicycle to protect the floor or carpet and for easier cleaning.
- Wear comfortable, good-quality walking or running shoes and appropriate clothing. Do not use this exercise bike with bare feet, sandals, socks or stockings!
- Always examine your exercise bike before using to ensure all parts are in working order.
- Do not leave children unsupervised near or on the exercise bicycle.
- Never operate the exercise bicycle where oxygen is being administered or where aerosol products are being used.
- Never insert any object or body parts into any opening.
- Service to your CardioMax exercise bike should only be performed by an authorized service representative, unless authorized and/or instructed by a Keys technician. Failure to follow these instructions will void the warranty.

ASSEMBLY PARTS

PART	PART NO.
CONSOLE	5
FRONT HANDLEBAR	23
REAR HANDLEBAR	22
CONSOLE TUBE	2
SEAT CUSHIONS	9, 10
SEAT CARRIAGE	3
FRAME	1
FOOT TUBES	4
PEDALS	30, 31
FOOT CAPS	21
WHEELS	20
CARRIAGE TUBE	16
SUPPORT TUBE	24
END CAP	17



(2) CONSOLE TUBE:--*1 	(3) SEAT CARRIAGE:--*1 	(4) FOOT TUBE:--*2 
(5) CONSOLE:--*1 	(16) CARRIAGE TUBE:--*1 	(17) END CAP:--*1 
(20) WHEEL:--*2 	(21) FOOT CAP:--*2 	(22) REAR HANDLEBAR:--*1 
(23) FRONT HANDLEBAR:--*1 	(24) SUPPORT TUBE:--*1 	(30) LEFT PEDAL:--*1 
(31) RIGHT PEDAL:--*1 	(44) M8*85mm CARRIAGE BOLT:--*4 	(45) M8 CAP NUT:--*6 
(49) M8 LOCKNUT:--*5 	(50) M8 ID*18.8mm OD FLAT WASHER:--*13 	(55) M8*57mm SCREW:--*2 
(56) M8*60mm SCREW:--*3 	(57) TP4*12mm SCREW:--*2 	(59) M5*10mm SCREW:--*4 
(66) RUBBER STOPPER:--*4 	(74) 11*58mm SCREW:--*2 	(75) M6*15mm SCREW:--*2 
(76) 6*13mm WASHER:--*2 	(77) 8*15mm WASHER:--*2 	(79) M8*15mm SCREW:--*4 
(82) M8*70mm SCREW:--*2 		

Assembly of CardioMax 835 Recumbent Bike

REMOVE ALL SECURITY TAPE AND WRAPPING
BEFORE BEGINNING.

1. Attach foot tubes (4) to the frame by using the carriage bolts (44), flat washers (50) and cap nuts (45) provided. Make sure the foot tube with wheels is assembled onto the front of the unit.

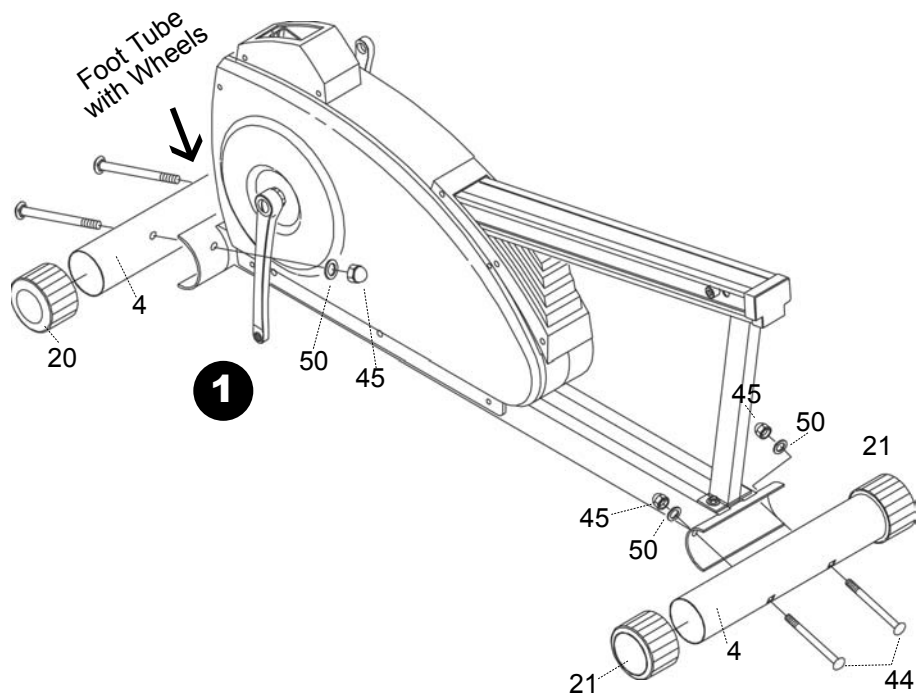

6

- 2a. Attach the rear handlebar (22) to the seat carriage (3) with the flat washers (50) and screws (79) provided. Connect the seat cushions (9,10) to the seat carriage (3) with the washers (78) and screws (80).

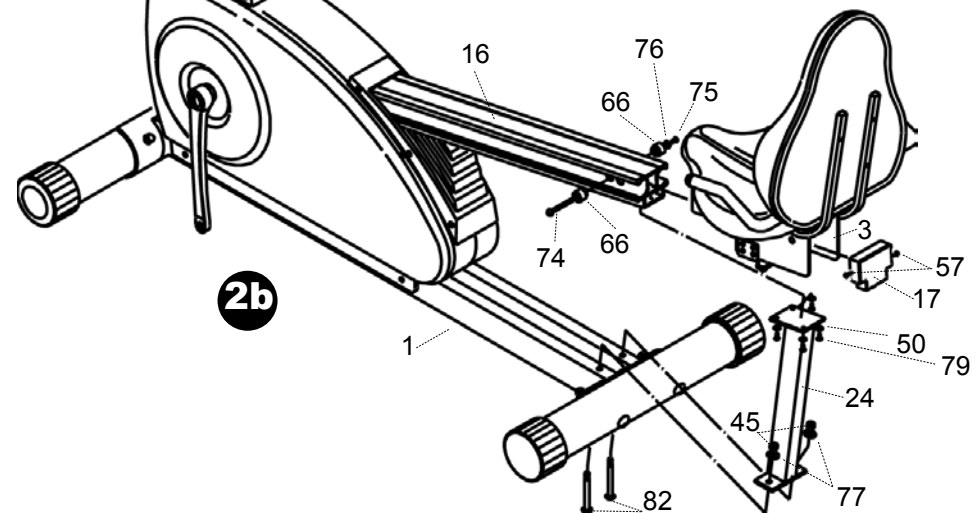
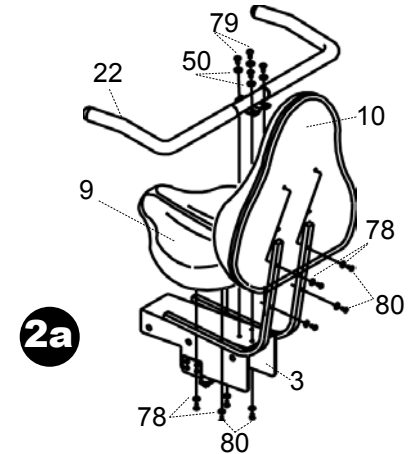

- 2b. First remove the support tube (24) from the main frame (1). Slide the assembled seat carriage tube (16). Re-assemble the support tube (24). Attach the end cap (17) with screws (57) and rear carriage tube rubber stoppers (66) with bolts (74, 75) and washer (76).

7

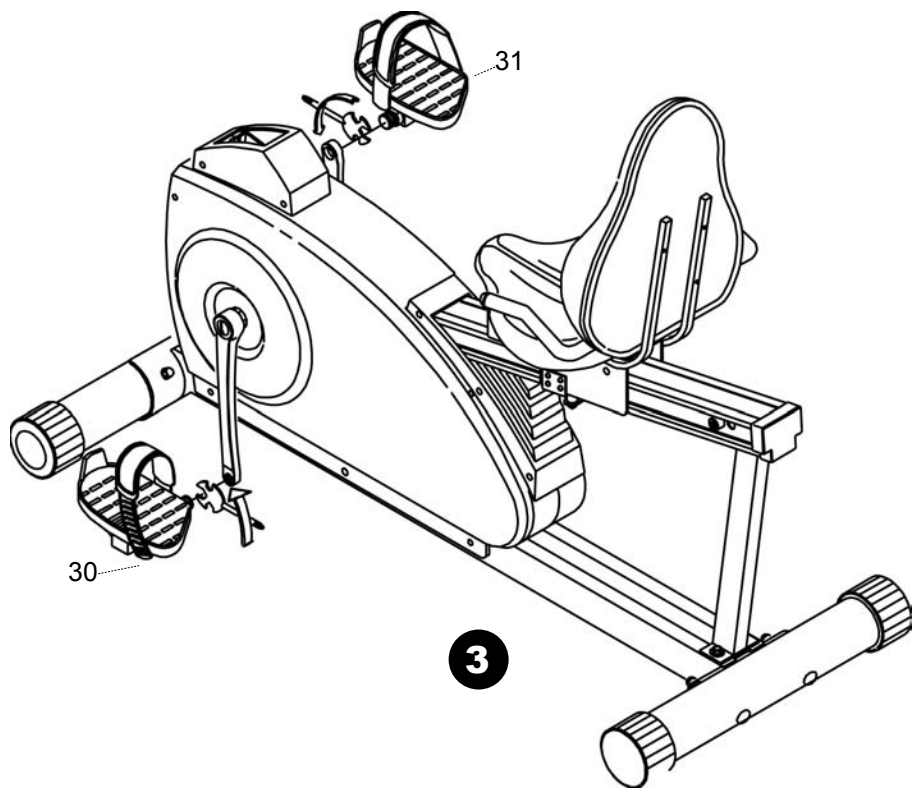

- 3.** Attach pedals (30, 31). Axles of pedals are branded “L” and “R.” The pedal marked “R” goes on the right hand side of the bike and the one marked “L” on the left hand side. Tighten the left pedal by turning counter-clockwise and the right pedal by turning clockwise.

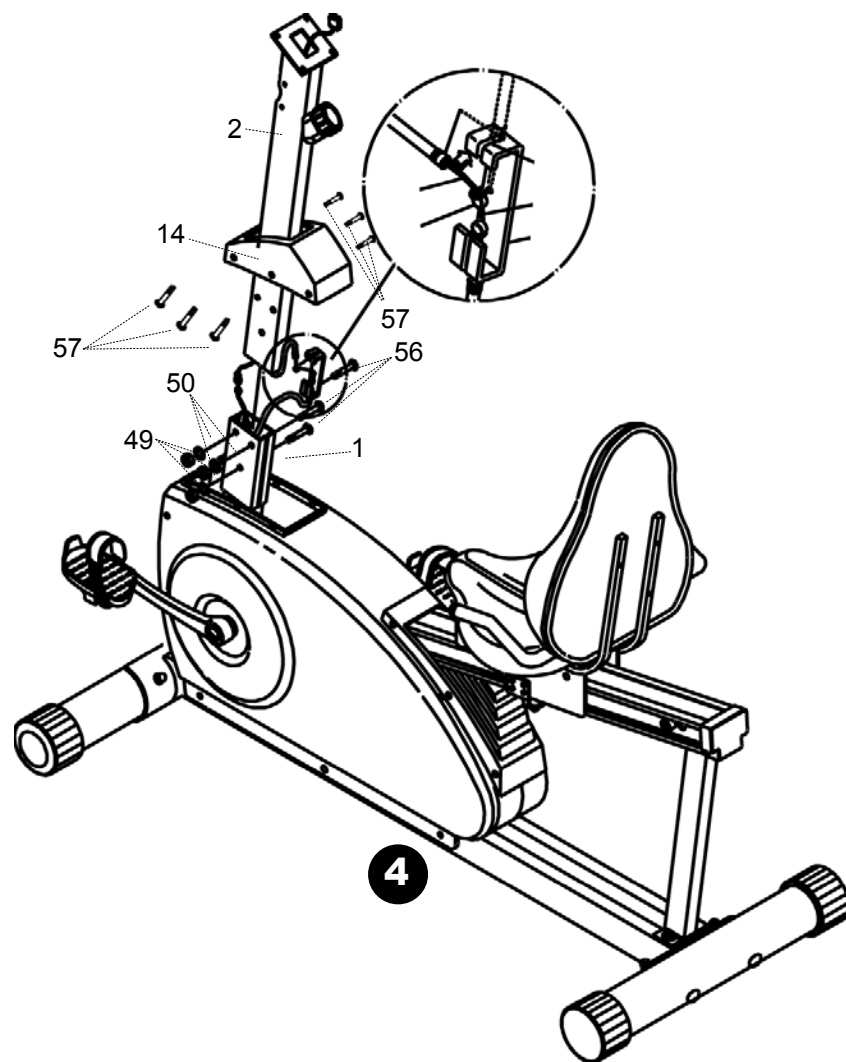

- 4.** Slide the console tube (2) through the console tube collar (14). Connect the computer cable in the console tube (2) to the computer cable in the main frame. Connect the tension cable in the console tube to the tension cable connection in the main frame. Attach the console tube (2) to the frame (1) with the locknuts (49), flat washers (50) and screws (56) provided. Attach the console tube collar (14) to the main frame (1) with screws (57).

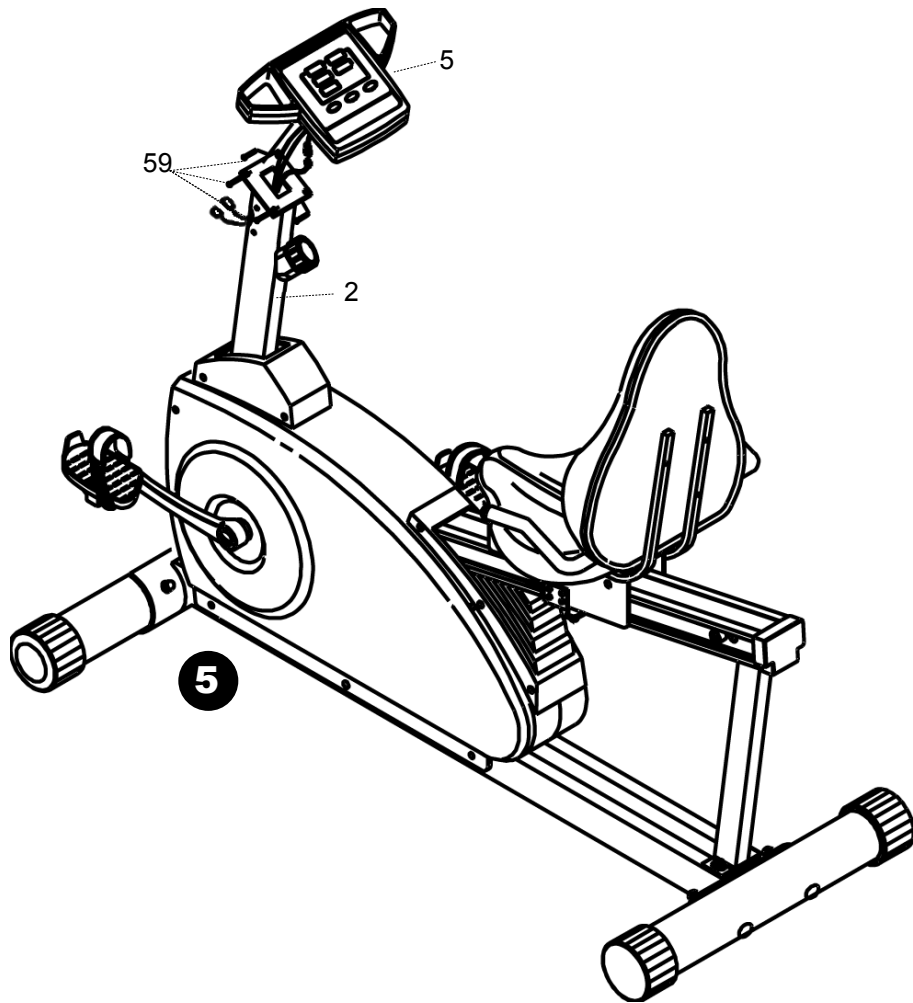

- 5.** Connect the computer cable at the top of the console tube (2) to the console (5). Both computer cable connections have white ends. Feed the pulse wires from the console (5) down into the console tube (2) and out the rear hole in the handlebar area. Attach the console tube (2) to the console (5) with the screws (59) provided and already attached to back of the console (5).

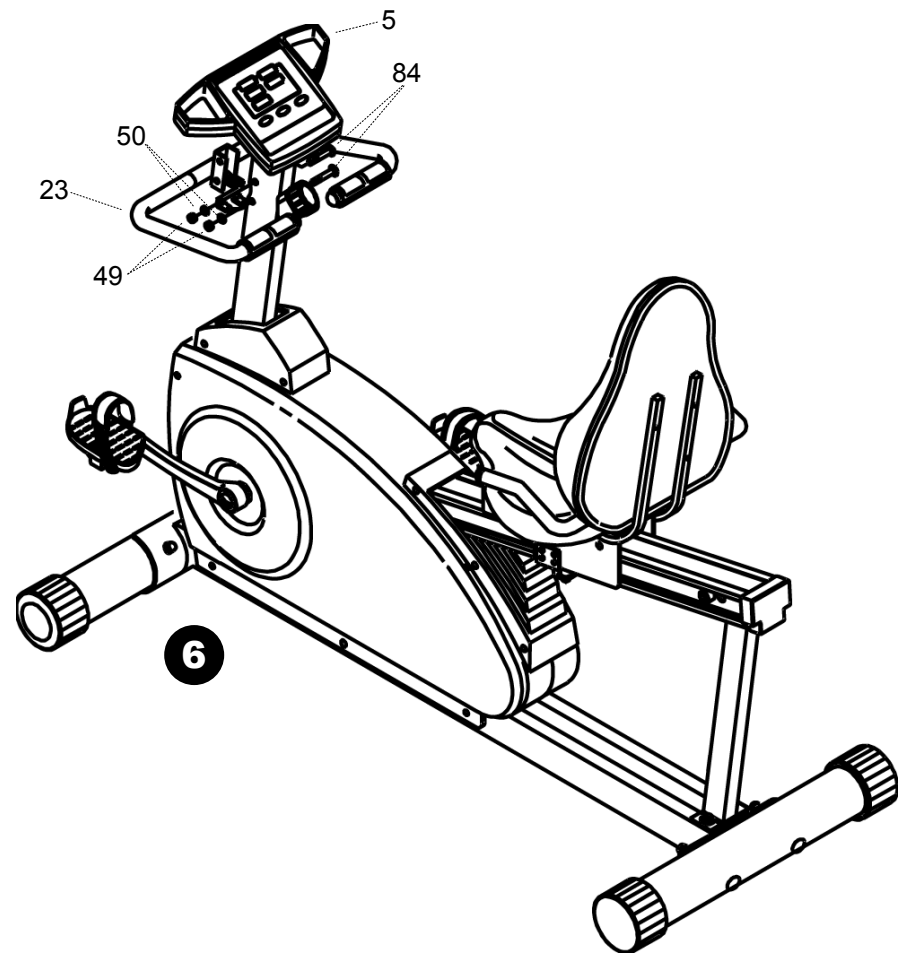

- 6.** Attach the pulse wires in the front handlebar (23) to the wires from the console (5). Connect the front handlebar (23) to the console tube (2) with the locknuts (49), flat washers (50) and screws (84) provided. Make sure not to “pinch” any of the pulse wires when connecting the handlebar to the console tube.

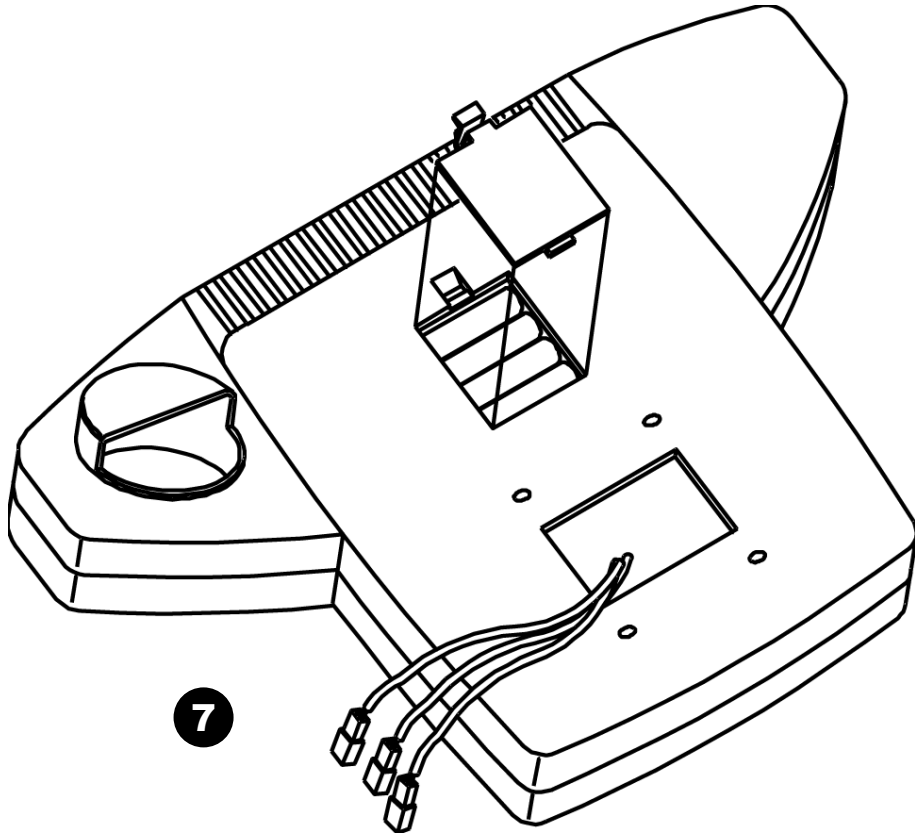

7. Load your console with the batteries provided. Batteries are 4 “AA” size.

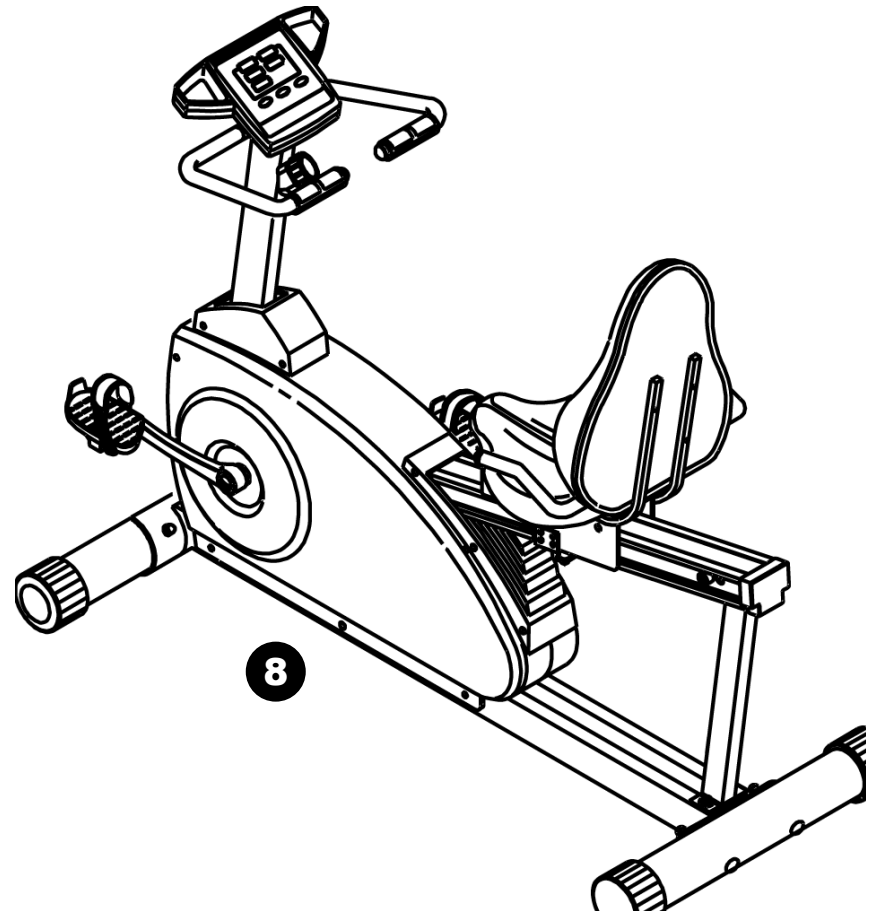

8. You have completed the assembly of your new CardioMax bike.

835 RECUMBENT PARTS LIST

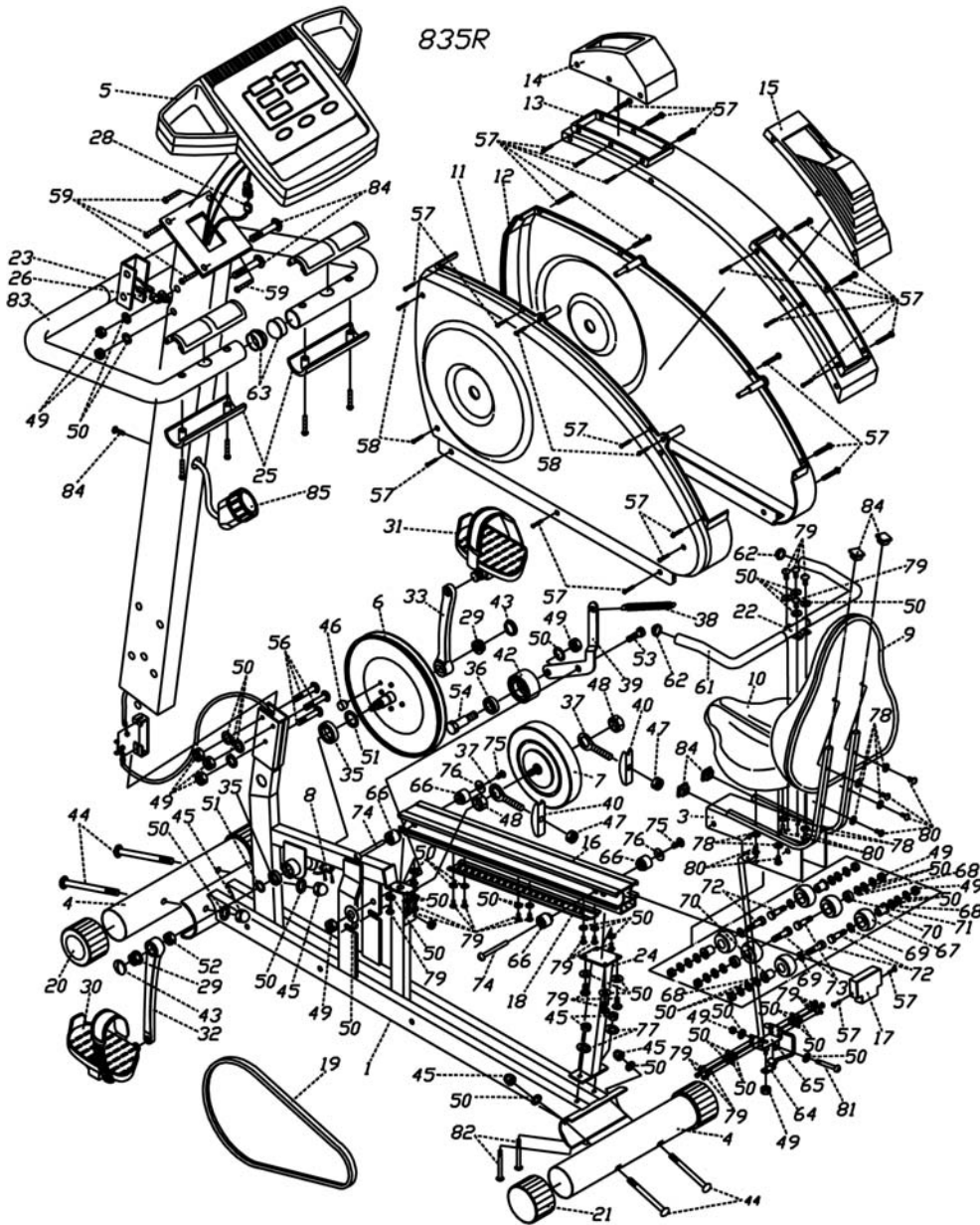

NO. PART	QTY	NO. PART	QTY
1 FRAME	1	45 M8 CAP NUT	4
2 CONSOLE TUBE	1	46 M6 LOCKNUT	4
3 SEAT CARRIAGE	1	47 6mm HEX NUT	2
4 FOOT TUBE	2	48 M10 CAP NUT	2
5 CONSOLE	1	49 M8 LOCKNUT	10
6 PULLEY	1	50 M8 IDX18.8mm OD14	
7 MAG BRAKE	1	FLAT WASHER	14
8 SENSOR	2	51 M20X32X2mm WASHER	2
9 SEAT CUSHION	2	52 CRANK NUT	2
10 BACK SEAT CUSHION	1	53 M8X17mm SCREW	1
11 BOTTOM LEFT COVER	2	54 M8X38mm SCREW	1
12 BOTTOM RIGHT COVER	1	55 M8X57mm SCREW	3
13 TOP COVER	1	56 M8X60mm SCREW	3
14 CONSOLE TUBE COLLAR	5	57 TP4X12mm SCREW	26
15 CONNECTING COVER	2	58 TP5X50mm SCREW	4
16 CARRIAGE TUBE	1	59 M5X10mm SCREW	4
17 END CAP	1	60 M6X45 MACHINE SCREW	4
18 ADJUSTING PLATE	2	61 REAR SLEEVE	1
19 "V" BELT	1	62 REAR BALL PLUG	2
20 WHEEL	2	63 FRONT BALL PLUG	2
21 FOOT CAP	2	64 CAM LOCK	1
22 REAR HANDLEBAR	2	65 SEAT CARRIAGE BRACKET	1
23 FRONT HANDLEBAR	2	66 RUBBER STOPPER	4
24 SUPPORT TUBE	2	67 SMALL ROLLER	6
25 HAND PULSE	2	68 M8 WAVED WASHER	6
26 PULSE WIRE	2	69 M13 WAVED WASHER	4
27 REED SWITCH WIRE	2	70 8*13mm BUSHING	4
28 EXTENSION WIRE	1	71 RETAINING RING	2
29 9mm NUT	2	72 8*34mm SCREW	4
30 LEFT PEDAL	1	73 BIASED 8*34mm SCREW	2
31 RIGHT PEDAL	1	74 11*58mm SCREW	2
32 LEFT CRANK	1	75 M6x15mm SCREW	2
33 RIGHT CRANK	1	76 6x13mm WASHER	2
34 LOCKING KNOB	1	77 8x169mm WASHER	2
35 6004 PRECISE BEARING	2	78 6x16mm WASHER	8
36 608 PRECISE BEARING	1	79 M8x15mm SCREW	12
37 EYEBOLT	2	80 ROUND HEAD	
38 SPRING	1	M6 X60mm SCREW	8
39 BELT TENSION BRACKET	1	81 M8x45 MACHINE SCREW	1
40 ADJUSTMENT CHANNEL	2	82 M8x70mm SCREW	2
41 SENSOR	1	83 FRONT SLEEVE	2
42 IDLER PULLEY	1	84 SQUARE CAP	4
43 CRANK CENTRAL CAP	2	85 TENSION KNOB	1
44 M8X85mm CARRDIAGE BOLT	4	86 M6x72mm SCREW	2

CM835 Display Instructions

BUTTON FUNCTIONS

- MODE** Press to select between functions: TIME, DISTANCE, CALORIES, and PULSE for target presetting.
- SET** Press to preset the target values of TIME, DISTANCE, CALORIES, and PULSE.
- RESET** Press to reset a function window to zero. To clear out the readings in all of the console windows, you must press and hold the Reset button for 3 seconds.

FUNCTIONS

Your CardioMax 835 console allows you to use a countdown function on the Time, Calories and Distance readouts. If any one of these is not set before beginning your workout, then they will count up instead of counting down. The console also allows you to set a high and low pulse rate that you would like to stay within (an audible beep will alert you when you are out of the pulse rate range you set). If you do not set a pulse rate range before beginning your workout, then it will simply give you your pulse rate reading without any audible beeps.

- TIME** Count Up – Calculates total workout time up to 99:59
Count Down – Counts down from the preset time to 00:00
- SPEED** Calculates current speed
- CALORIES** Count Up – Calculates total calories burned up to 999
Count Down – Counts down from the preset calories entered to 0.0

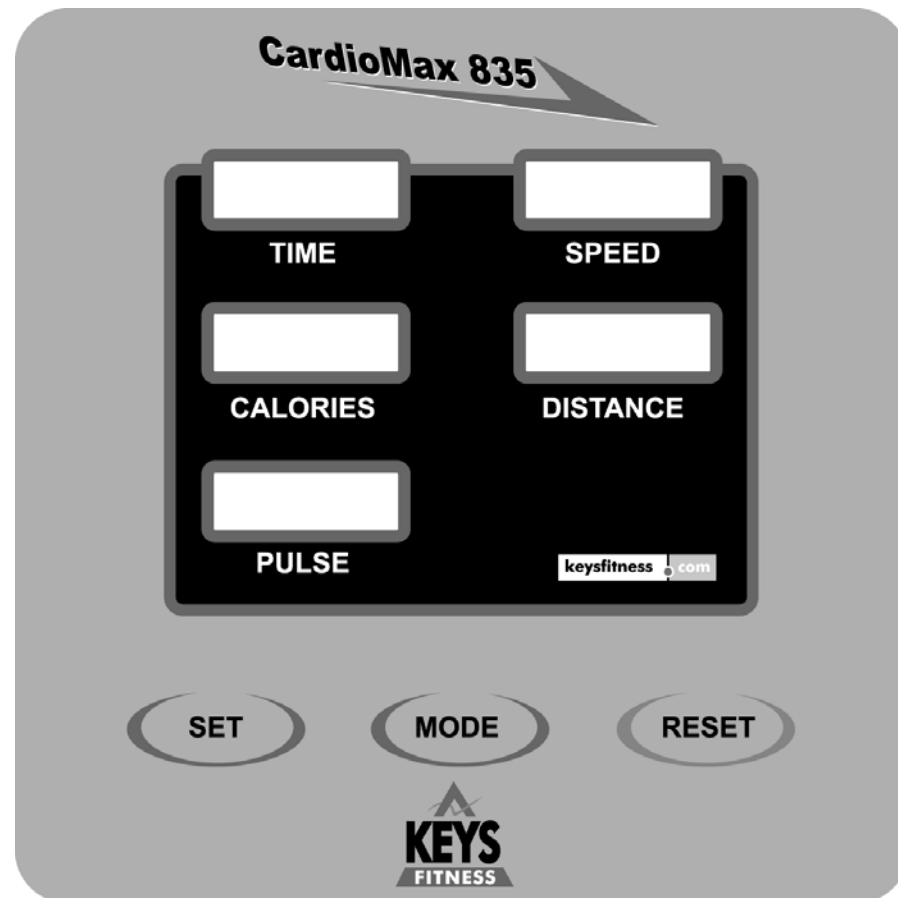

- DISTANCE** Count Up – Calculates total miles up to 99.9
Count Down – Counts down from the preset miles entered to 0.0
- PULSE** The monitor will display your current heart rate within 5 seconds after holding the heart rate sensors. For an accurate heart rate reading, you must use both hands on the heart rate sensors.

To set the countdown function for Time, Calories, or Distance:

Press the Mode key until the correct screen has been chosen. Press the Set key until the desired reading appears in the window you are setting.

If the countdown mode is set for the Time, Calories, or Distance before your workout begins, then the console will alert you when you have reached your goal with an audible beeping. To turn off the alert, simply depress the Mode key. After the countdown mode has reached your selected goal, it will then begin counting upward. This will allow you to continue to track your workout if you decide to keep exercising.

To set the high and low heart rate range:

Press the Mode key until the up or down arrow in the Pulse window has been chosen. Press the Set key until the desired reading appears in the Pulse window.

NOTE

Without signal for a period of 4 minutes, the LCD display will automatically shut off. All information will be stored and appear again once activity is returned.

Turn on the monitor by pressing any button or by beginning exercise.

Monitoring Your Heart Rate

To obtain the greatest cardiovascular benefits from your exercise workout, it is important to work within your target heart rate zone. The American Heart Association (AHA) defines this target as 60%-75% percent of your maximum heart rate.

Your maximum heart rate may be roughly calculated by subtracting your age from 220. Your maximum heart rate and aerobic capacity naturally decreases as you age. This may vary from one person to another, but use this number to find your approximate effective target zone. For example, the maximum heart rate for an average 40 year-old is 180 bpm. The target heart rate zone is 60%-75% of 180 or 108-135 bpm. See *Fitness Safety* on page 20.

Before beginning your workout, check your normal resting heart rate. Place your fingers lightly against your neck, or against your wrist over the main artery. After finding your pulse, count the number of beats in 10 seconds. Multiply the number of beats by six to determine your pulse rate per minute. We recommend taking your heart rate at these times; at rest, after warming up, during your workout and two minutes into your cool down, to accurately track your progress as it relates to better fitness.

During your first several months of exercising, the AHA recommends aiming for the lower part of the target heart rate zone- 60%, then gradually progressing up to 75%.

According to the AHA, exercising above 75% of your maximum heart rate may be too strenuous unless you are in top physical condition. Exercising below 60% of your maximum will result in minimal cardiovascular conditioning.

Check your pulse recovery rate – If your pulse is over 100 bpm five minutes after you stop exercising, or if it's higher than normal the morning after exercising, your exertion may have been too strenuous for your current fitness level. Rest and reduce the intensity next time.

Fitness Safety

The target heart rate chart indicates average rate zones for different ages. A variety of different factors (including medication, emotional state, temperature and other conditions) can affect the target heart rate zone that is best for you. Your physician or health care professional can help you determine the exercise intensity that is appropriate for your age and condition.

(MHR) = Maximum Heart Rate

(THR) = Target Heart Rate

220 - age = maximum heart rate (MHR).

MHR x .60 = 60% of your maximum heart rate.

MHR x .75 = 75% of your maximum heart rate.

For example, if you are 30 years old, your calculations will be as follows:

220 - 30 = 190

190 x .60 = 114 (low end or 60% of MHR)

190 x .75 = 142 (high end or 75% of MHR)

For a 30 year-old the (THR) Target Heart Rate would be 114-142.

See Table on right for additional calculations.

TARGET HEART RATE ZONE

