

**1-888-340-0482**  
**Monday-Friday**  
**8:30-5:30 Central Time**



**Keys Fitness Products, L.P.**  
**4009 Distribution Dr.**  
**Suite 250**  
**Garland, Texas 75041**

# **CardioMax**

## **520 Upright**

### **OWNER'S MANUAL**

#### **QUESTIONS?**

Call Our Toll Free  
Keys Fitness Helpline  
1-888-340-0482

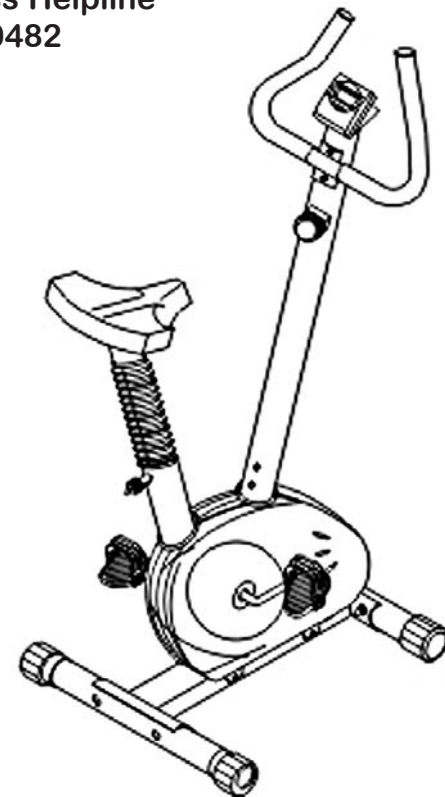

#### **CAUTION!**

Please read the precautions and instructions in this manual before using this equipment. Please save this manual for future reference.

**Keys Fitness Products, L.P.**  
**P.O. Box 551239**  
**Dallas, Texas 75355-1239**



**Keys Fitness is committed to quality products that demonstrate our commitment to excellence!**

**Keys Exercise Bike  
Model: CardioMax 520 Upright**

**Questions?**

*Please call if:*

- you need assistance about operating your exercise bike
- parts are missing
- parts become worn or need to be replaced

**1-888-340-0482  
Monday-Friday  
8:30-5:30 Central Time**

*When requesting information please have the following available:*

- The Name
- The Model
- The Part Number
- The Description

**KEYS FITNESS PRODUCTS, LP - LIMITED WARRANTY**

**PRODUCT:** KEYS CARDIOMAX 520 UPRIGHT  
**HOME USE WARRANTY:** Parts: 1 year

This Limited Warranty applies in the United States and Canada to products manufactured or distributed by Keys Fitness Products, LP ("Keys") under the KEYS brand name. The warranty period to the original purchaser is listed above in the table.

Keys warrants that the Product you have purchased for use from Keys or from an authorized Keys reseller is free from defects in materials or workmanship under normal use during the warranty period. Your sales receipt, showing the date of purchase of the Product, is your proof of purchase. This warranty only extends to you, the original purchaser. It is not transferable to anyone who subsequently purchases the Product from you. It excludes expendable parts. This Limited Warranty becomes VALID ONLY if the product is purchased through a Keys Fitness authorized dealer unless otherwise authorized by Keys Fitness in writing.

During the warranty period Keys will repair or replace (at Keys' option) the product if it becomes defective, malfunctions, or otherwise fails to conform with this Limited Warranty under normal use. In repairing the Product, Keys may replace defective parts, or at the option of Keys, serviceable used parts that are equivalent to new parts in performance. All exchanged parts and Products replaced under this warranty will become the property of Keys. Keys reserves the right to change manufacturers of any part to cover any existing warranty.

This warranty DOES NOT COVER shipping charges, export taxes, custom duties and taxes, or any other charges associated with transportation of the parts or Product.

To obtain warranty service, you must contact a Keys authorized retailer, service technician or Keys Fitness at our phone numbers located in this manual. Any parts determined to be defective must be returned to Keys to obtain warranty service. You must prepay any shipping charges, export taxes, custom duties and taxes, or any other charges associated with transportation of the parts or Product. In addition, you are responsible for insuring any parts or Product shipped or returned. You assume the risk of loss during shipment. You must present Keys with proof-of-purchase documents (including the date of purchase). Any evidence of alteration, erasing or forgery of proof-of-purchase documents will be cause to void this Limited Warranty.

This warranty does not extend to any product not purchased from Keys or from an authorized Keys reseller. This Limited Warranty does not extend to any Product that has been damaged or rendered defective; (a) as a result of accident, misuse, or abuse; (b) by the use of parts not manufactured or sold by Keys; (c) by modification of the Product or normal wear and tear; (d) operation on incorrect power supplies; or (e) as a result of service by anyone other than Keys, or an authorized Keys warranty service provider. Product on which the serial number has been defaced or removed is not eligible for warranty service. Should any Product submitted for warranty service be found ineligible, an estimate of repair cost will be furnished and the repair will be made if requested by you upon Keys' receipt of payment or acceptable arrangements for payment.

EXCEPT AS EXPRESSLY SET FORTH IN THIS WARRANTY, KEYS MAKES NO OTHER WARRANTIES, EXPRESSED OR IMPLIED, INCLUDING ANY IMPLIED WARRANTIES OF MERCHANTABILITY AND FITNESS FOR A PARTICULAR PURPOSE. KEYS EXPRESSLY DISCLAIMS ALL WARRANTIES NOT STATED IN THIS LIMITED WARRANTY. ANY IMPLIED WARRANTIES THAT MAY BE IMPOSED BY LAW ARE LIMITED TO THE TERMS OF THIS LIMITED WARRANTY. NEITHER KEYS NOR ANY OF ITS AFFILIATES SHALL BE RESPONSIBLE FOR INCIDENTAL OR CONSEQUENTIAL DAMAGES. SOME STATES DO NOT ALLOW LIMITATIONS ON HOW LONG AN IMPLIED WARRANTY LASTS OR THE EXCLUSION OR LIMITATION OF INCIDENTAL OR CONSEQUENTIAL DAMAGES, SO THE ABOVE LIMITATIONS OR EXCLUSION MAY NOT APPLY TO YOU. This Limited Warranty gives you specific legal rights and you may also have other rights that may vary from state to state. This is the only express warranty applicable to Keys-branded products. Keys neither assumes nor authorizes anyone to assume for it any other express warranty.

PLEASE SEND IN THE ATTACHED WARRANTY CARD WITHIN TEN (10) DAYS OF PURCHASE TO REGISTER YOUR EXERCISE BIKE WITH KEYS FITNESS PRODUCTS, LP.

MAIL WARRANTY CARD TO:  
KEYS FITNESS PRODUCTS, PO BOX 551239, DALLAS, TX 75355

## Before You Start

Thank you for purchasing a Keys exercise bicycle! This quality product you have chosen was designed to meet your needs for cardiovascular exercise.

Prior to assembly, remove components from the box and verify that all the listed parts were supplied. Assembly instructions are described in the following steps and illustrations.

### Important Safety Information WARNING!









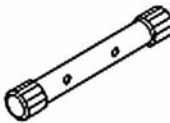
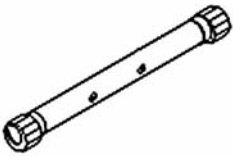

- 1) Before using this exercise bicycle or starting any exercise program, consult your physician. This is especially important for persons over the age of 35 and/or persons with pre-existing health problems. Keys Fitness Products LP assumes no responsibility for personal injury or property damage sustained by or through the use of this product.
- 2) To reduce the risk of electrical shock, burns, fire or other possible injuries to the user, it is important to review this manual and the following precautions before operation.

## Safety Precautions and Tips

It is the owner's responsibility to ensure that all users of this exercise bike have read the Owner's Manual and are familiar with warnings and safety precautions.

- This exercise bike has a user maximum capacity of 250 pounds.
- The CardioMax Exercise bike should only be used on a level surface and is intended for indoor use only. It should not be placed in a garage, patio or near water. Keys recommends a bicycle mat be placed under the bicycle to protect floor or carpet and for easier cleaning.
- Wear comfortable, good-quality walking or running shoes and appropriate clothing. Do not use this exercise bike with bare feet, sandals, socks or stockings!
- Always examine your exercise bike before using to ensure all parts are in working order.
- Do not leave children unsupervised near or on the exercise bicycle.
- Never operate the exercise bicycle where oxygen is being administered or where aerosol products are being used.
- Never insert any object or body parts into any opening.
- Service to your CardioMax exercise bike should only be performed by an authorized service representative, unless authorized and/or instructed by a Keys technician. Failure to follow these instructions will void the warranty.

## Assembly Parts

 <p>MAIN FRAME <b>No.1</b></p>	 <p>FRONT STABILIZER <b>No.21</b></p>	 <p>REAR STABILIZER <b>No.15</b></p>
 <p>PEDALS, (L) <b>No.13</b>, (R) <b>No.14</b>,</p>	 <p>SEAT POST <b>No.49</b></p>	 <p>SEAT <b>No.52</b></p>
 <p>PLASTIC BELLOWS <b>No.70</b></p>	 <p>TENSION CABLE <b>No.59</b></p>	 <p>TENSION CONTROLLER <b>No.58</b></p>
 <p>HANDLEBAR POST <b>No.56</b></p>	 <p>COMPUTER <b>No.61</b></p>	 <p>HANDLEBAR <b>No.62</b></p>

## Assembly Accessories

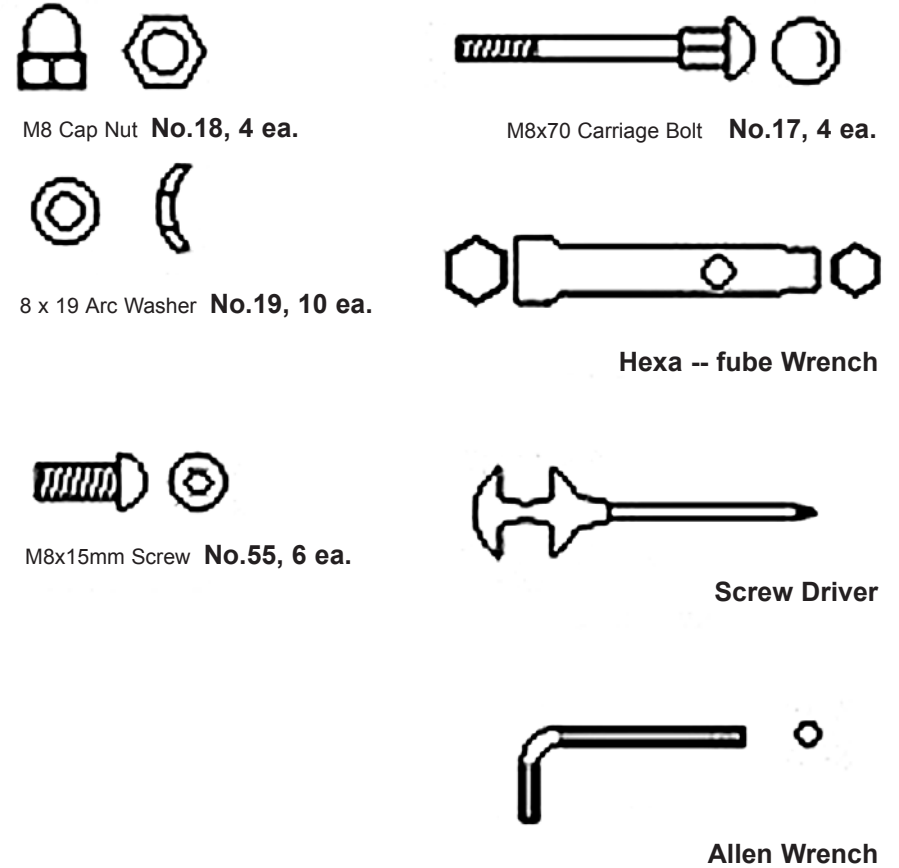

## Assembly of CM520 Exercise Bike

### REMOVE ALL SECURITY TAPE AND WRAPPING BEFORE BEGINNING.

1. Attach Front Stabilizer (21) and Rear Stabilizer (15) to the Main Frame (1) using carriage Bolts (17), Washers (19) and Nuts (18).

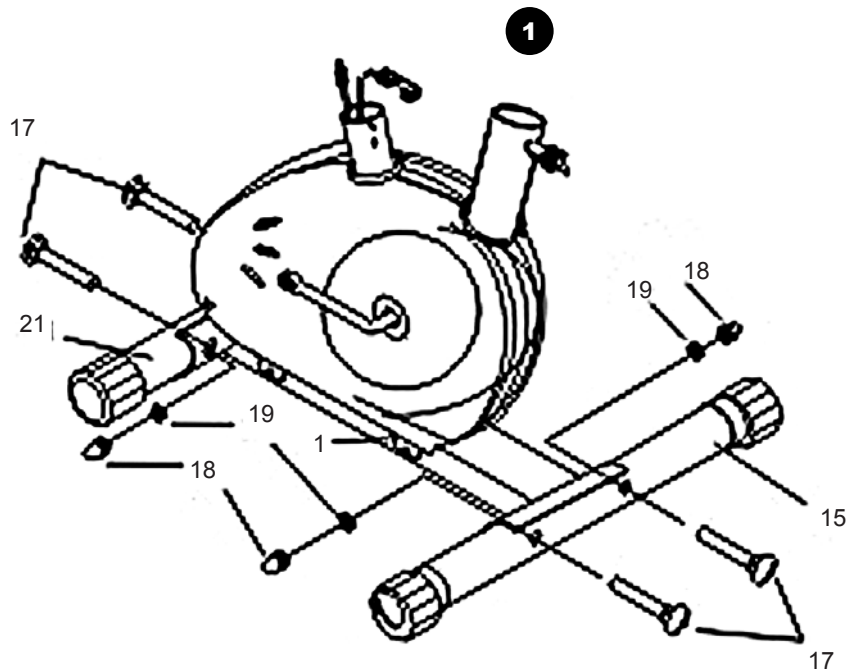

6

2. Attach Right and Left Pedals (13, 14) to the Pedal Crank (9). Axles of the pedals are branded "L" and "R." The pedal marked "R" goes on the right hand side of the bike and the one marked "L" on the left hand side. Tighten the left pedal by turning counter-clockwise and the right pedal by turning clockwise.

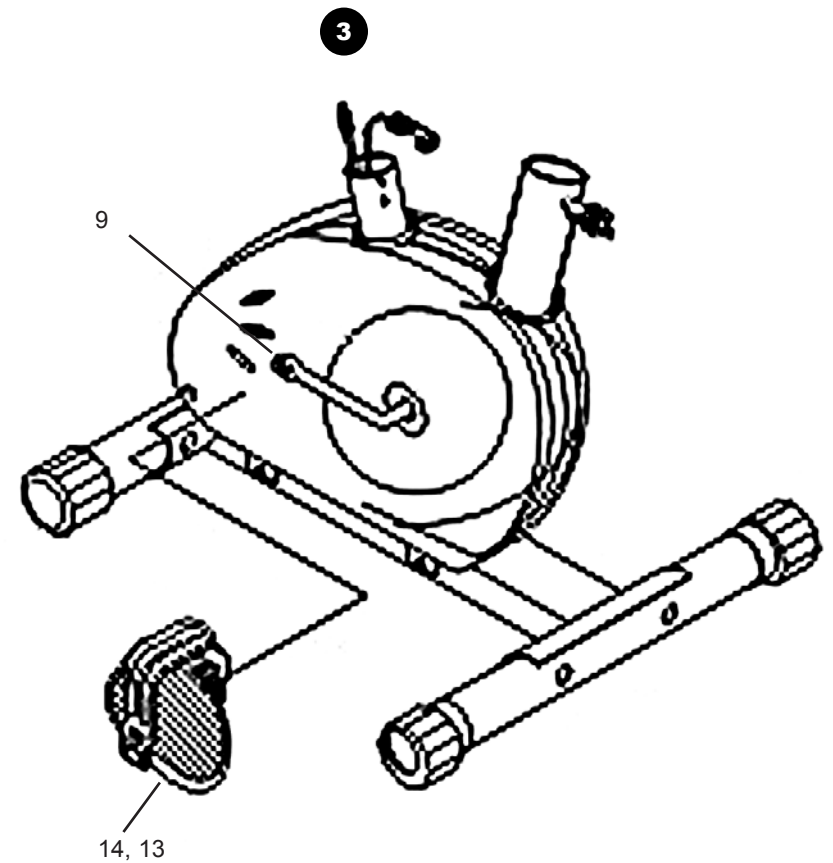

7

3. Attach the Seat (52) to the Seat Post (49) with the Nuts (50) and Washers (51) provided.

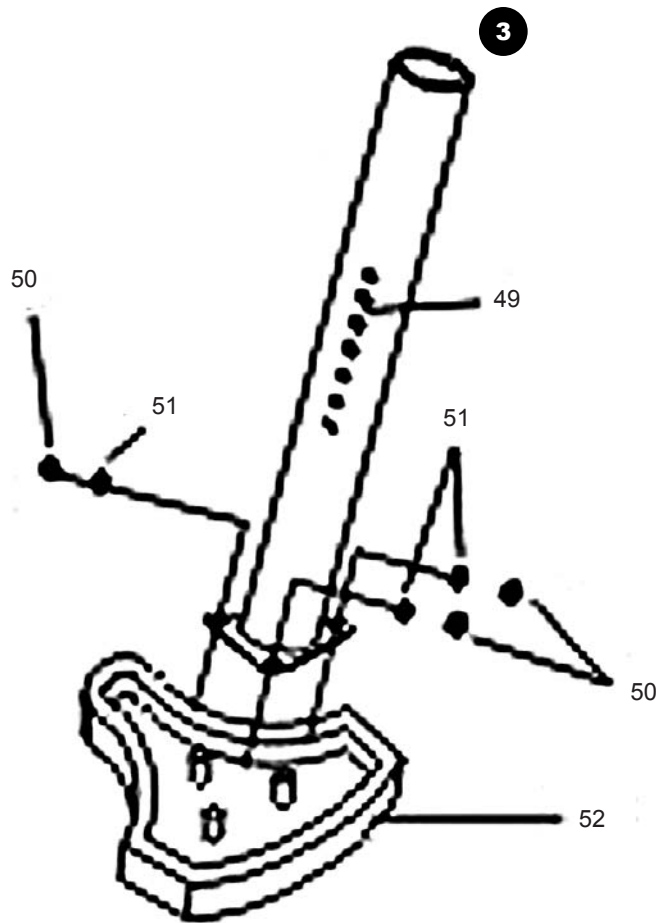

8

4. Slide the Plastic Bellow (70) (optional) onto the Seat Post (49). Then insert the Seat Post (49) into the Main Frame (1). Use the Seat Adjustment Knob (47) to adjust to the desired seat height.

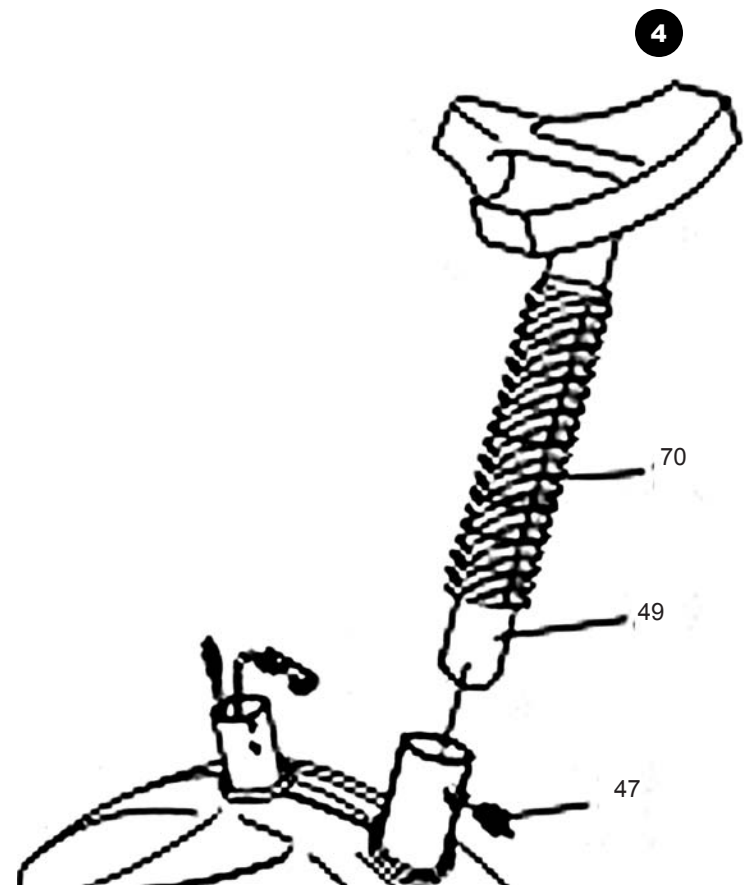

9

5. Connect the Extension Wire (54) in the Upright Post (56) to the Sensor Wire (45) in the Main Frame (1). Slide the Tension Cable (59) from the Main Frame (1) up through the Upright Post (56). Connect the Upright Post (56) to the Main Frame (1) using Hex Bolts (55) and Arc Washers (19).

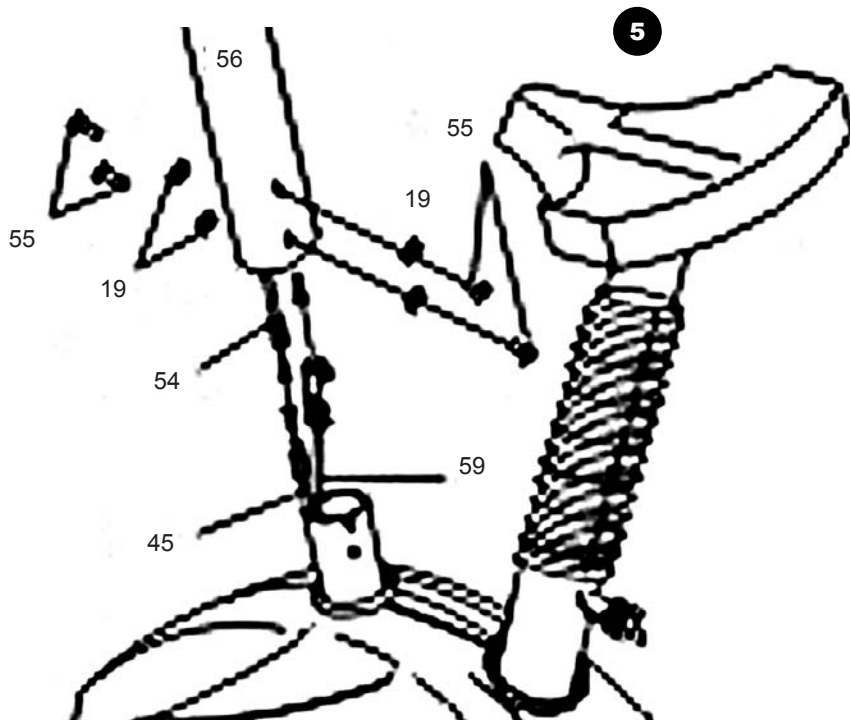

10

6. Pull the Tension Cable (59) out of the Upright Post (56) and connect to the Resistance Knob (58) as in Steps 1 and 2:

**Step 1:** Put the Tension Controller cable end into the spring hook.

**Step 2:** Pull the Tension Controller cable into the gap of the bracket. Insert the Tension Controller (58) into the Upright Post (56) and connect with the screw attached (57).

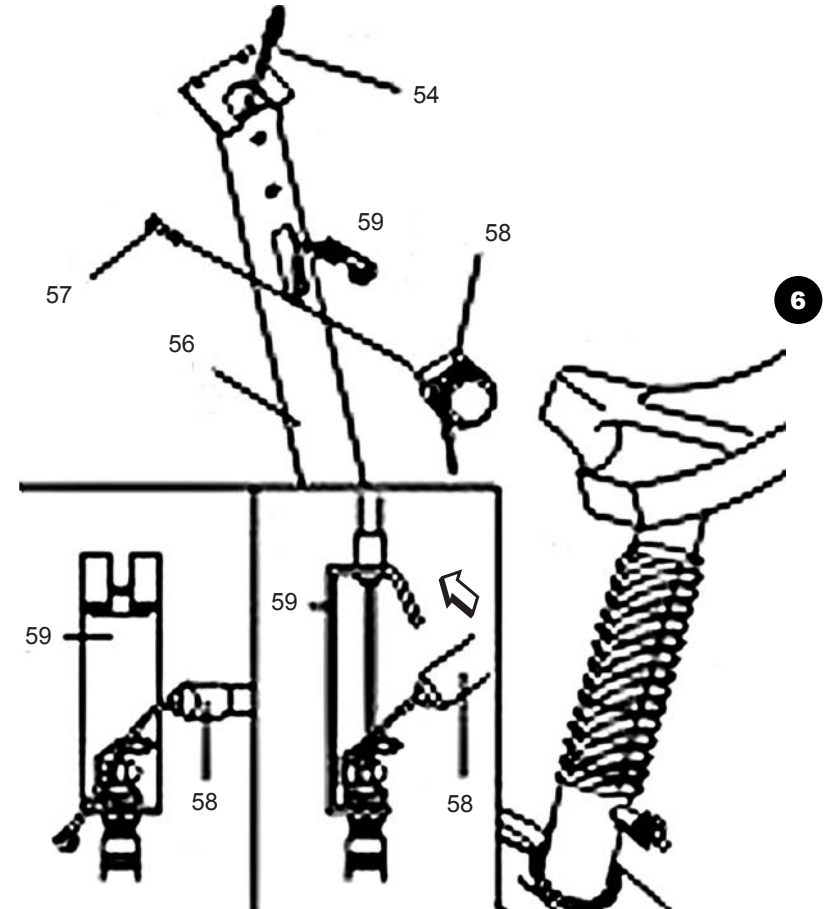

11

7. Connect the computer cable at the top of the Upright Tube (54) to the Computer (61). Attach the Computer (61) to the Upright Post (56) with the screws attached. Open the battery cover on the back of the computer and install 2 AA batteries.

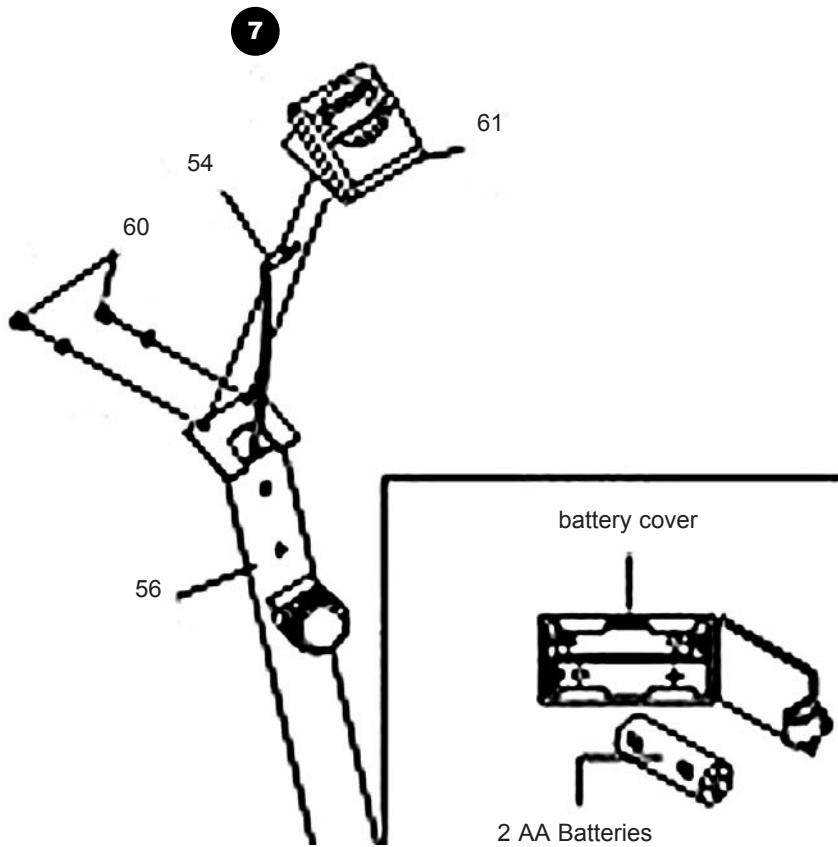

12

8. Connect the Handlebar (62) to the Upright Post (56) with the Hex Bolts (55) and Arc Washers (19).

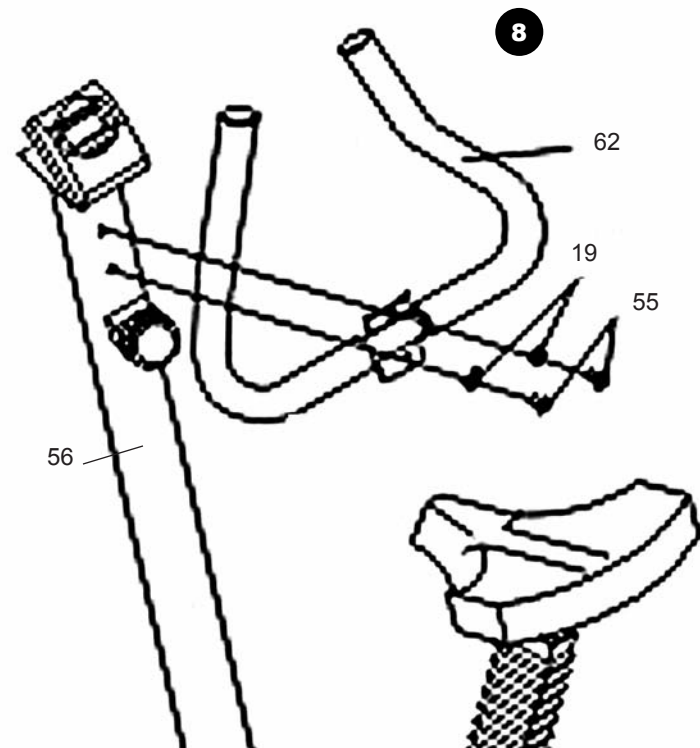

13



## CM520 Exercise Bike Parts List

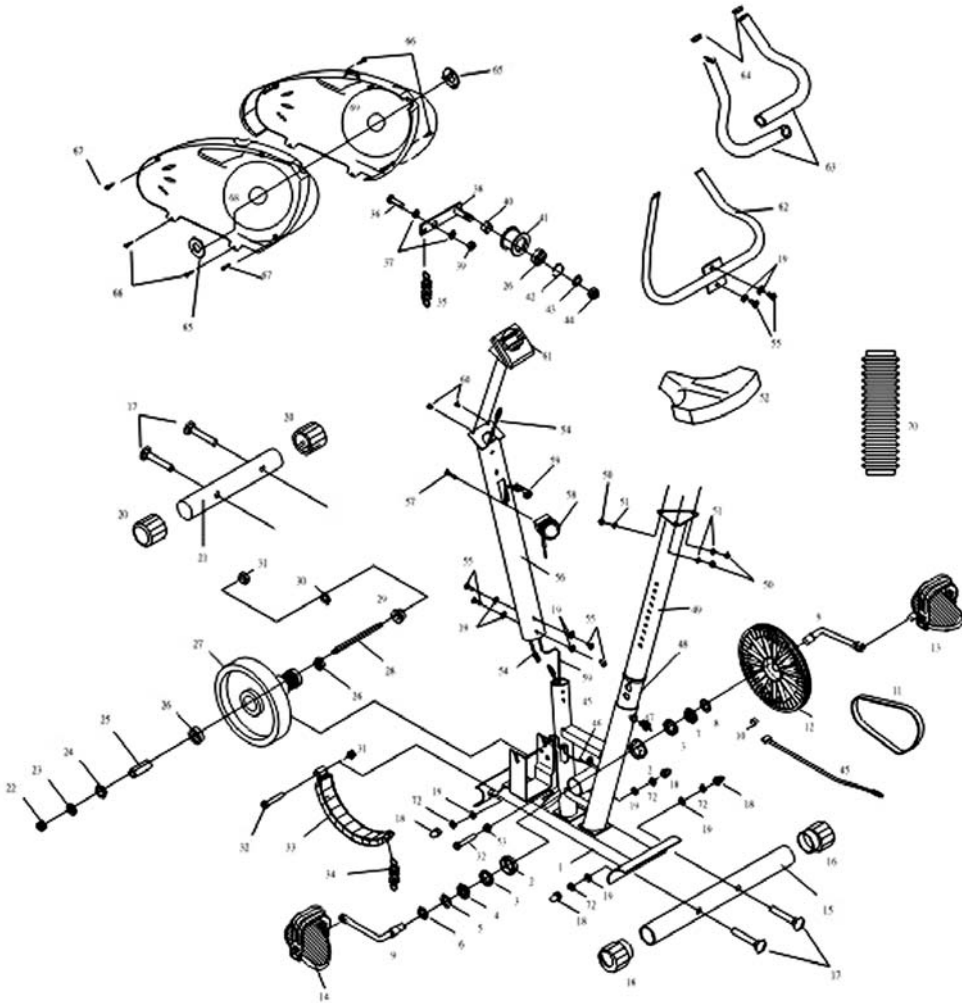

NO.	PART	QTY	NO.	PART	QTY
1	MAIN FRAME	1	36	HEX BOLT 3/8**26	2
2	BEARING HOUSING	2	37	WASHER	1
3	BALL BEARINGS	2	38	IDLER ARM	1
4	INSIDE BEARING COLLAR	1	39	NYLOCK NUT 3/8"	1
5	WASHER	1	40	IDLER WHEEL SPACER	1
6	HEX NUT	2	41	IDLER WHEEL	1
7	OUTSIDE BEARING COLLAR	1	42	TENSION SPRING	1
8	WASHER	1	43	WASHER	1
9	CRANK	1	44	NYLOCK NUT M10	1
10	MAGNET	1	45	SENSOR WIRE	1
11	BELT	1	46	SCREW M3*10	1
12	PULLEY	1	47	SEAT ADJUSTMENT KNOB	1
13	RIGHT PEDAL	1	48	PORT SUPPORT BUSHING	1
14	LEFT PEDAL	1	49	SEAT POST	1
15	REAR STABILIZER	1	50	NYLOCK NUT M8	3
16	HEIGHT REGULATOR	2	51	WASHER	3
17	CARRIAGE BOLT M8*70	4	52	SEAT	1
18	NUT M8	4	53	NUT M8	1
19	ARC WASHERS	10	54	EXTENSION WIRE	1
20	END CAP	2	55	SCREW M8X15	6
21	FRONT STABILIZER	1	56	UPRIGHT POST	1
22	NUT 3/8"	1	57	SCREW M5*	1
23	WASHER	1	58	RESISTANCE KNOB	1
24	BC NUT 3/8"	1	59	TENSION CABLE	1
25	SPACER	1	60	SCREWM5*10	2
26	BEARINGS	3	61	COMPUTER	1
27	FLY WHEEL	1	62	HANDLEBAR	1
28	AXLE	1	63	FOAM GRIP	2
29	GREASED BEARING	1	64	HANDLEBAR CAP	2
30	WASHER	5	65	CRANK CAP	2
31	NYLOCK NUT M8	2	66	SCREW	4
32	GHEX BOLTM8*60	2	67	ROUND HEAD SCREW	3
33	MAGNETIC PLATE	1	68	LEFT COVER	1
34	MAGNETIC SPRING	1	69	RIGHT COVER	1
35	IDLER SPRING	1	70	PLASTIC BELLOWS	1

## Console Functions

*Please see insert for LCD console display instructions.*

## Troubleshooting:

Should at any point your computer display partial values or numbers, it may require you to remove the batteries for approx 15 second, then replace them.

### **Batteries:**

On the rear side of the computer you will find a door leading to the batteries. Use 2 (1.5 volt AA/Mignon -- Included ), always beware of the correct polling of positive and negative. Removing the batteries sets all values to 0.

### **Old Batteries:**

Used batteries do not belong in the trash. Please dispose of your batteries in a responsible manner, as a consumer you are legally responsible for seeking out your neighborhood collection/disposal location. Often you will find them where batteries are sold. Remember to make sure that they are empty and that there is no risk of short circuit.



## Monitoring Your Heart Rate

To obtain the greatest cardiovascular benefits from your exercise workout, it is important to work within your target heart rate zone. The American Heart Association (AHA) defines this target as 60%-75% percent of your maximum heart rate.

Your maximum heart rate may be roughly calculated by subtracting your age from 220. Your maximum heart rate and aerobic capacity naturally decreases as you age. This may vary from one person to another, but use this number to find your approximate effective target zone. For example, the maximum heart rate for an average 40 year-old is 180 bpm. The target heart rate zone is 60%-75% of 180 or 108-135 bpm. See *Fitness Safety* on page 18.

Before beginning your workout, check your normal resting heart rate. Place your fingers lightly against your neck, or against your wrist over the main artery. After finding your pulse, count the number of beats in 10 seconds. Multiply the number of beats by six to determine your pulse rate per minute. We recommend taking your heart rate at these times; at rest, after warming up, during your workout and two minutes into your cool down, to accurately track your progress as it relates to better fitness.

During your first several months of exercising, the AHA recommends aiming for the lower part of the target heart rate zone- 60%, then gradually progressing up to 75%.

According to the AHA, exercising above 75% of your maximum heart rate may be too strenuous unless you are in top physical condition. Exercising below 60% of your maximum will result in minimal cardiovascular conditioning.

Check your pulse recovery rate – If your pulse is over 100 bpm five minutes after you stop exercising, or if it's higher than normal the morning after exercising, your exertion may have been too strenuous for your current fitness level. Rest and reduce the intensity next time.

## Fitness Safety

The target heart rate chart indicates average rate zones for different ages. A variety of different factors (including medication, emotional state, temperature and other conditions) can affect the target heart rate zone that is best for you. Your physician or health care professional can help you determine the exercise intensity that is appropriate for your age and condition.

**(MHR) = Maximum Heart Rate**

**(THR) = Target Heart Rate**

**220 - age = maximum heart rate (MHR).**

**MHR x .60 = 60% of your maximum heart rate.**

**MHR x .75 = 75% of your maximum heart rate.**

**For example, if you are 30 years old, your calculations will be as follows:**

**220 - 30 = 190**

**190 x .60 = 114 (low end or 60% of MHR)**

**190 x .75 = 142 (high end or 75% of MHR)**

**For a 30 year-old the (THR) Target Heart Rate would be 114-142.**

**See Table on right for additional calculations.**

## Target Heart Rate Zone

