

2511 ADIRONDACK BENCH

Contents:

- (1) Seat, (1) Back
- (2) Arm Rests
- (2) Front Chair legs
- (2) Back Chair legs
- (2) Cross Braces

- (18) 1/4 - 20 x 2" Bolts
- (2) 1/4 - 20 x 2 1/2" Bolts
- (1) #10 x 3" Screw
- (10) Washers
- (10) Locknuts

Tools Required:

- #3 Phillips Head Screwdriver
- 7/16" Wrench

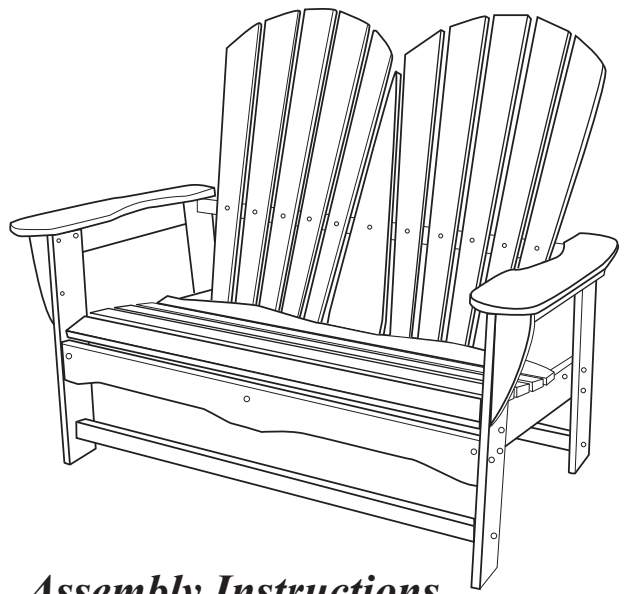
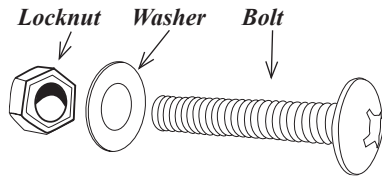

1.

a. Align predrilled holes then insert bolts to attach **front legs**.

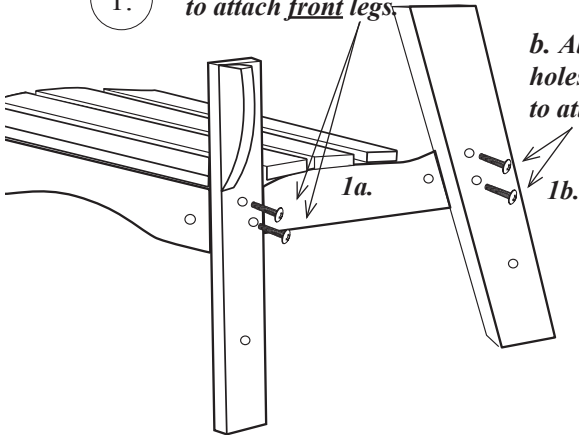

b. Align predrilled holes then insert bolts to attach **back legs**.

2.

Place arm rest on top of chair legs, align front predrilled holes, insert bolt.

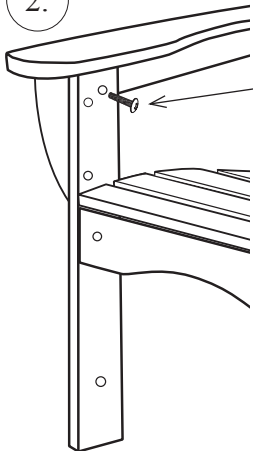

3.

Attach the back of the chair by aligning holes on the arm and the seat to insert bolt.

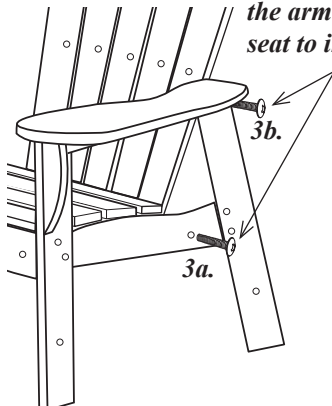

4.

Attach the braces to the legs by aligning holes and inserting a 2" bolt.

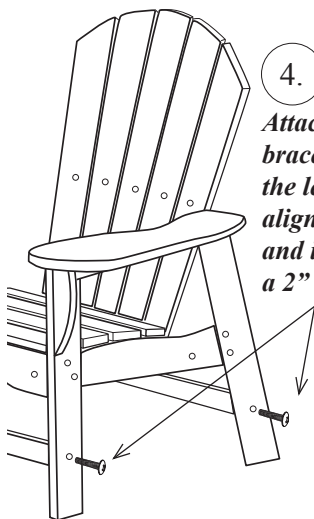

Slide washer then locknut onto end of bolt then tighten.

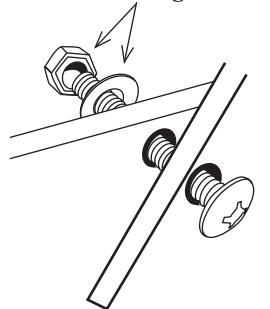

5.

Insert the bolt thru the center seat brace into the center of the back of bench.

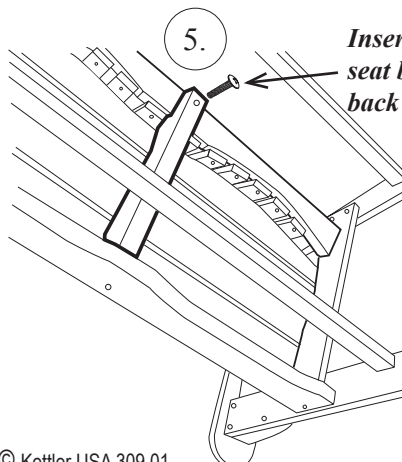

Assembly Instructions

1.

a. With the wing on the post facing front, align the predrilled holes on front leg to the seat and insert the 1/4 - 20 x 2" Bolts through the leg in thru the seat. Clean any plastic residue from the bolt then slide a washer on. Screw on the locknut and then tighten it with the wrench and phillips screwdriver.

b. Align the predrilled holes on the back leg to the seat and insert the 1/4 - 20 x 2" Bolts through the leg in thru the seat. Clean any plastic residue from the bolt then slide a washer on. Screw on the locknut and then tighten it with the wrench and phillips screwdriver. Repeat on the other front leg.

2.

Place arm rest on top of chair legs align the front predrilled holes and insert the 1/4 - 20 x 2" Bolts through the leg and in thru the arm. Clean off any plastic residue then slide a washer on the end of bolt. Screw on the locknut and then tighten it with the wrench and phillips screwdriver.

3.

a. Attach the back of the chair to the seat by aligning holes and inserting a 1/4 - 20 x 2" Bolt then tighten with a phillips screwdriver.

b. Attach the back of the chair to the arm by aligning holes and inserting a 1/4 - 20 x 2" Bolt thru the arm, leg and into the chair back, then tighten with a phillips screwdriver. Repeat on both sides.

4.

Attach the cross braces of the chair to the legs by aligning holes and inserting a 1/4 - 20 x 2" Bolt through the leg into the cross brace and tighten with a phillips screwdriver.

Repeat on other leg.
Do Front and Back cross braces.

5.

Attach the center seat brace underneath to the back, insert a #10 x 3" screw thru the brace into the center of the bottom back support then tighten with the screwdriver.

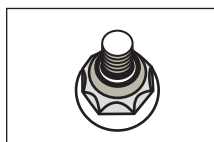

Properly Seated
Washer and Nut.



Made in the U.S.A.
www.kettlerusa.com
info@kettlerusa.com



Care & Maintenance

Ocean Comfort products are constructed from HDPE (High Density Polyethelene), primarily a recycled material. UV inhibitors are also added to resist fading. Simply maintain your furniture by cleaning with soap and warm water to ensure its long lasting beauty. A soft bristle brush can be used on any tough to clean stains. Stainless steel hardware is used in the assembly of these products and should be rinsed regularly with fresh water if being used in a coastal environment.

KETTLER Limited Warranty

Ocean Comfort products are guaranteed for a period of 20 years (for residential use) and 5 years (for commercial use), starting from original purchase date. This warranty covers defects in materials and/or workmanship and does not apply to the hardware. Warranty not applicable to any products deemed as misused, abused or damaged due to an uncontrollable act of nature.

*For Parts and Service, please contact us directly at 866-804-0440 or email parts@kettlerusa.com



Made in the U.S.A.

KETTLER® International Inc. • 1355 London Bridge Road • Virginia Beach, VA 23453
www.kettlerusa.com • info@kettlerusa.com