

KETTLER®

Assembly Instructions „SCOOTER PRINCESS“

08451-799

Adult Assembly Required

USA



Printed on 100% recycled paper.!

picture similar

Tools required for adult
assembly (included):



Not included:



FREIZEIT MARKE KETTLER

KETTLER® International Inc. · 1355 London Bridge Road · Virginia Beach VA 23453
www.kettlerusa.com
info@kettlerusa.com



Read these instructions carefully before assembling the product or using it for the first time. They contain important information for your safety and for the correct use and maintenance of this KETTLER® product. Keep the instructions in a safe place for information or for ordering spare parts.

This KETTLER® product has been designed in accordance with the latest standards of safety and subjected to constant quality monitoring. The data gained from this quality process is then incorporated in the development of our products. For this reason, we reserve the right to make changes in design and technology in order to offer our customers products of the highest standard of quality at all times. In spite of this, should you have any ground for complaint, please contact KETTLER®.

For your safety

- This toy vehicle should be used for its intended purpose only, i.e. one (1) child only. It should not be used in any other way, as this may be dangerous. The manufacturer cannot be held liable for damage or injury caused by incorrect use.
- This product is a toy and is not suitable for use in traffic or on public roads.
- Always keep a watchful eye on your child in order to avoid risks by thoughtless and hasty movements.
- Please care for the fact that the scooter is only used on safe ground.
- The scooter is an unlighted play implement. Its use in the dark is dangerous.
- In case of a sudden and/or strong turn of the handlebar the scooter could be caused to tip. Danger of injuries!
- The scooter must not be connected with other vehicles, sports or similar devices and not be driven/pulled by them. Never subject your child on the scooter to speeds exceeding walking pace!
- We recommend that a child using the scooter should wear a child's bicycle helmet and safety pads.
- Damaged components may endanger the safety of your child or shorten the lifespan of the product. Inspect it at regular intervals to ensure that none of the components are damaged and that none of the bolts or other joints have worked loose.
- Replace worn or damaged parts immediately and ensure that the product is not used again until this has been done. If any parts require replacement, use only original spares manufactured by KETTLER®.
- This child's wheeled toy conforms to the stipulated safety regulations European standard EN 71-1/3 („Safety regulations for childrens toys“, max. weight of user: 110 lbs. The proprietary KETTLER® tunnel tubing alone has a 400lb weight limit; this does not include wheel axle, fork, etc.). Incorrect repairs or alterations (removal of original parts or addition of other parts etc.) may be a source of danger to the user.
- This toy is designed only for private use (no commercial or public use).

- This product is suitable for children between 3 – 6 years with a body height from 35 – 45 inches.
- **⚠ CAUTION:** This package contains small parts which, before assembly, present hazardous sharp edges or points and/or a potential choking hazard to children under the age of three. Care should be taken during unpacking and assembly to ensure that all small parts are accounted for and kept out of the reach of children.

Use of the Toy

- **WARNING:** Adult supervision is required. Never use near steps, slopes, driveways, hills, roadways, alleys or swimming pool areas. Always wear shoes. Never allow more than one rider (without a tandem seat). The use of protective gear and a Safety Helmet is highly recommended.
- Ensure that the toy vehicle is not used until it has been properly assembled and checked by an adult person.
- Do not transport any objects on the scooter.
- Always adjust the use of the scooter to the conditions encountered.
- Scooters do not possess a continuously effective brake system. Therefore, safeguard the scooter against rolling away
- Instruct your child how to use the vehicle correctly and draw attention to possible sources of danger.
- Although dangerous situations are unlikely to occur if the toy is used correctly, children at play should, if possible, be supervised.
- Please bear in mind that there is **always a danger** of children injuring themselves while using swings, climbing frames, toy vehicles or similar equipment.
- When using the toy vehicle, the user should always wear strong closed toe shoes.
- When children are at play, situations may arise which cannot be predicted by the manufacturer and for which he cannot be held responsible.
- Before use, always check all screws and plug-in connections as well as respective safety devices fit correctly.
- Never use corrosive or abrasive substances to clean the toy. Never use substances which may cause pollution of the environment.
- Lubricate the bearing sleeves of the wheels and the handlebars with a few drops of oil every two or three months.

Assembly of the toy vehicle

- The toy vehicle must be assembled carefully by an adult person. Study the assembly instructions carefully before beginning work. Assemble the vehicle in the exact sequence shown by the letters in the diagrams. This is essential for the safe function and use of the scooter.

- Please note that there is **always** a danger of injury when working with tools or doing manual work. Therefore please be careful when assembling this scooter.
- Ensure that your working area is free of possible sources of danger, for example don't leave any tools lying around. Always dispose packaging material in such a way that it may not cause any danger. There is always a **risk of suffocation** if children play with plastic bags!
- Bolt all the parts together loosely at first, and check that they have been assembled correctly. Tighten the locknuts by hand until resistance is felt, **then use wrench to finally tighten nuts completely against resistance (locking device)**. Then check that all screw connections have been tightened firmly. **Attention:** once locknuts have been unscrewed they no longer function correctly (the **locking device is destroyed**), and must be replaced.
- The grips can be pushed onto the handlebars more easily if they are first soaked in warm water.
- Please keep original packaging of this article, so that it may be used for transport at a later date, if necessary. Goods may **only** be returned after prior arrangement and in (internal) packaging, which is safe for transportation, in the original box if possible. It is important to provide a detailed defect description / damage report!
- For technical reasons, we reserve the right to carry out preliminary assembly work (e.g. addition of tubing plugs).
- When ordering spare parts, always state the full item number, spare-part number, the quantity required and the serial number of the product.
Example order: item # 08451-799 / spare part no. 12802003 / 1 piece/ S/N ...
Important: spare part prices do not include fastening material; if fastening material (bolts, nuts, washers etc.) is required, this should be clearly stated on the order by adding the words „with fastening material“.

KETTLER® limited warranty

THERE ARE NO WARRANTIES, EXPRESSED OR IMPLIED, MADE BY EITHER THE DISTRIBUTOR OR THE MANUFACTURER ON KETTLER PRODUCTS, EXCEPT THE MANUFACTURER'S LIMITED WARRANTY AGAINST DEFECTS IN MATERIAL SET OUT BELOW:

This KETTLER® Limited Warranty applies to products sold through the KETTLER® Authorized Dealer Network to the original retail purchaser and authenticated by proof of purchase from a retailer located in the United States. Any shipments made under this warranty will be shipped to the United States only. Any shipment outside of the United States will be at the sole cost of the customer. This KETTLER® Limited Warranty is a manufacturer's warranty and is not changed or modified by additional warranties extended by individual retailers at the point of sale. Manufacturer warrants this product to be free from defects in material at the time of the product's tender of delivery for a period of 3 years for residential use. This Limited Warranty is not transferable and does not cover normal wear and tear (including, but not limited to, damage and wear

to tires, power shocks, drive belts and other non-durable parts). The liability of the manufacturer under this Limited Warranty shall not include any liability for direct, indirect, or consequential damages resulting from the defect. This Limited Warranty is void if the product is damaged by accident, unreasonable use, improper service, failure to follow instructions provided, modification from its original state, or other causes determined not arising out of defects in material.

This warranty gives you specific legal rights. Should this product become defective due to material within the warranty period, contact KETTLER® Parts & Service Dept. by phone at 866.804.0440, fax at 757.563.9273, or e-mail at parts@kettlerusa.com.

THIS LIMITED WARRANTY IS EXPRESSLY IN LIEU OF ANY OTHER WARRANTIES, EXPRESSED OR IMPLIED, INCLUDING ANY IMPLIED WARRANTY OF MERCHANTABILITY OR FITNESS FOR A PARTICULAR PURPOSE, AND OF ANY OTHER OBLIGATIONS OR LIABILITY ON THE PART OF THE MANUFACTURER. KETTLER® NEITHER ASSUMES NOR AUTHORIZES ANY OTHER PERSON TO ASSUME FOR IT ANY OTHER LIABILITY IN CONNECTION WITH SUCH PRODUCTS.

KETTLER® International Inc., 1355 London Bridge Road · Virginia Beach VA 23453
For parts or service ONLY call 1-866-804-0440 or send e-mail to:

parts@kettlerusa.com

call (866) 804-0440 fax (757) 563-9273.







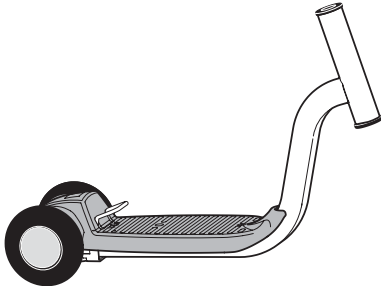
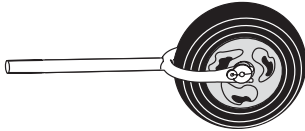
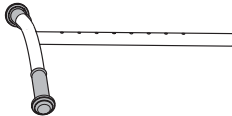

www.kettlerusa.com

info@kettlerusa.com

The manufacturer reserves the right to make changes reflecting product or other technical advances. The content of these instructions is accurate at the date of printing.

Checklist

	1	✓
	1	
	1	

		1/1	
		1	
		1	
		1	
		1	
	M8x40	1	
	M8	1	
	3,9x16	2	
		1	

1

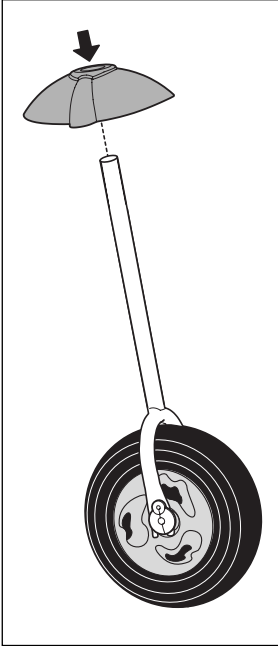

2

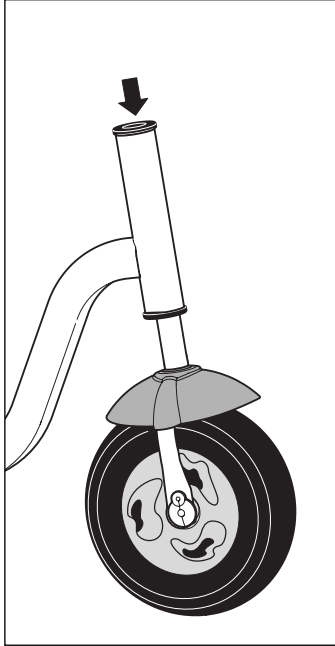

3

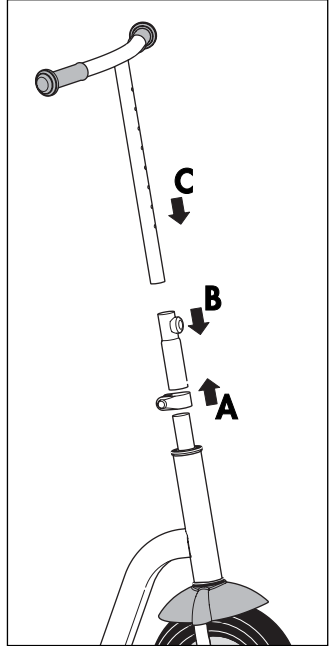

4a

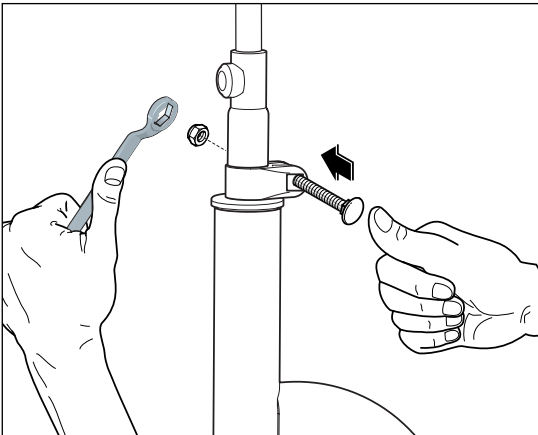

4b

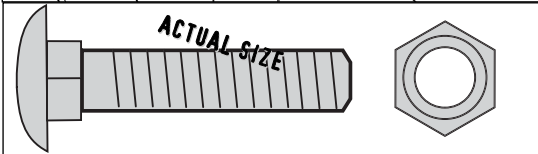
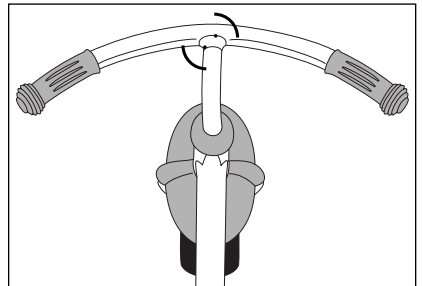

5

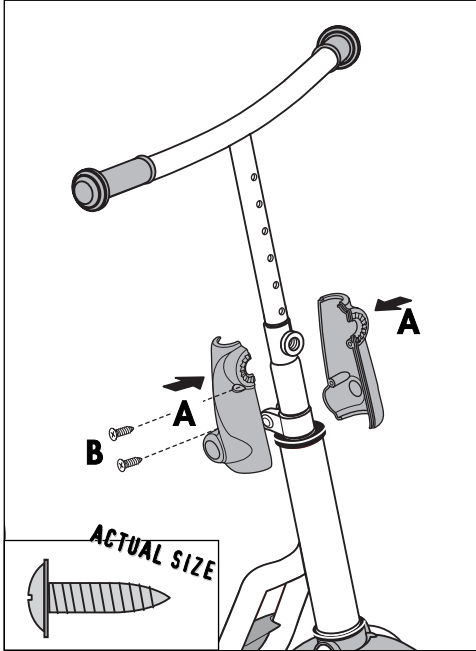

6

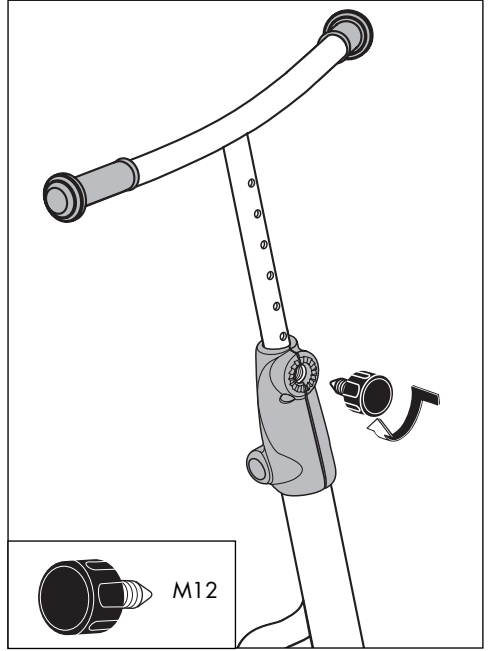

Handling

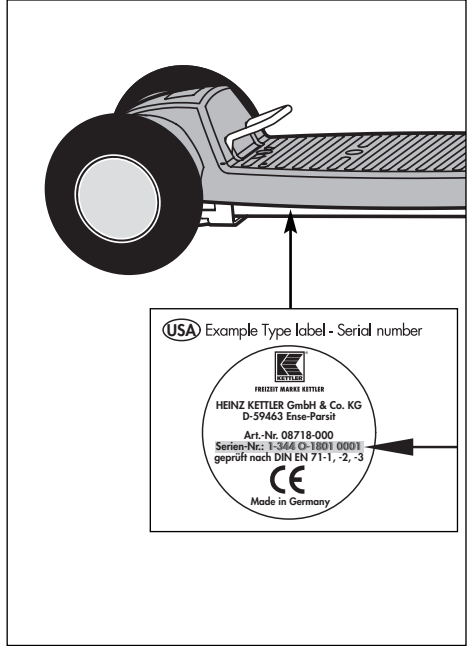
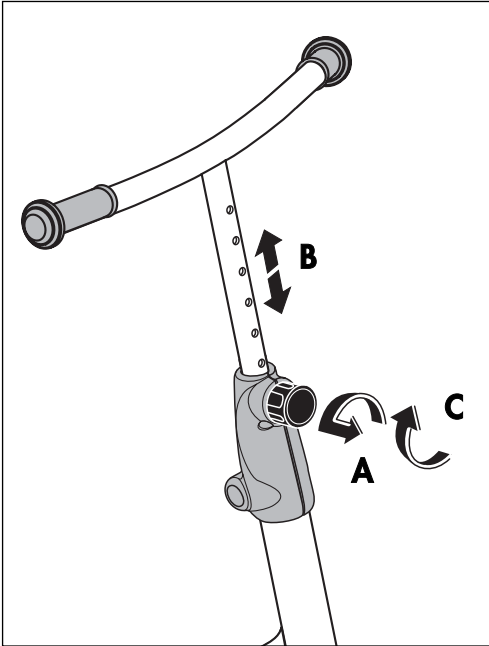

Spare parts drawing

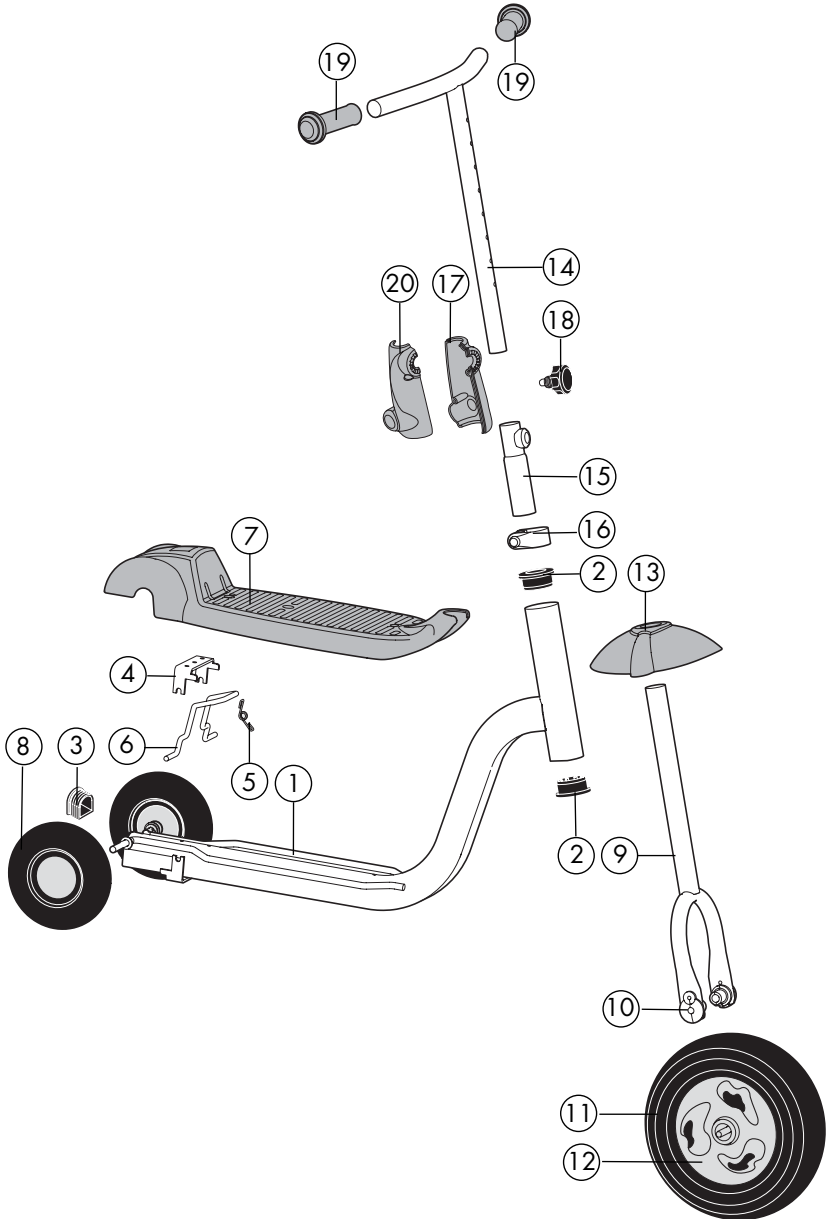

Spare parts list 08451-799

no.	description	qty.	spare part no.
1	frame (complete)	1	91611406
2	frame bushings (3247)	2	70121718
3	plug 35x41mm	1	70113610
4	brakeplate	1	97200263
5	brake spring	1	25716925
6	brake	1	25024005
7	foot plate (3355)	1	70121727
8	rear wheel	2	10116061
9	wheel fork	1	91620372
10	wheel bearing	2	10122155
11	front wheel with caps	1	15170300
12	wheel covers	2	70121883
13	fender (3336)	1	70121728
14	handle bar	1	97100398
15	reducing tube	1	91650357
16	clamp	1	11500007
17	covering, left	1	70121753
18	quick release knob M12	1	91670081
19	grip	2	10111037
20	covering, right	1	70121752
21	hardware bag w/o fig.	1	91680500



FREIZEIT MARKE KETTLER

