

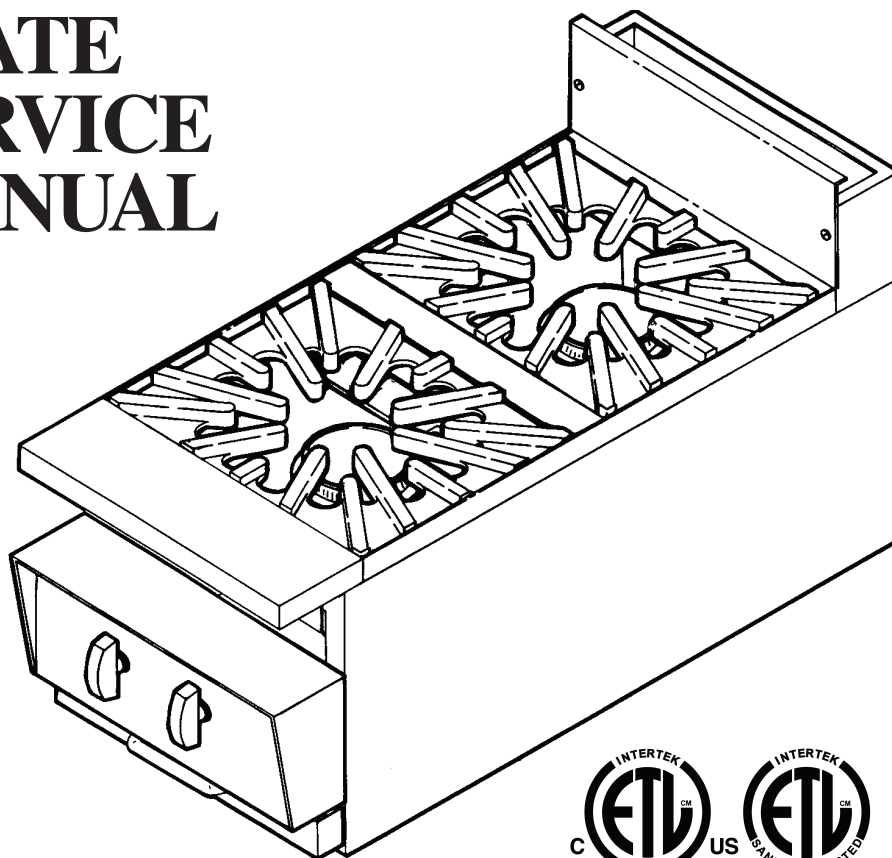

*"Serving Those Who Serve The Very Best"*

# MG-2/MG-4 GAS HOT PLATE SERVICE MANUAL



**KEEP THIS MANUAL FOR TRAINING NEW PERSONNEL**

1-800-KEATING  
[www.keatingofchicago.com](http://www.keatingofchicago.com)

---

# TABLE OF CONTENTS

---

## SECTION I INTRODUCTION

General Information . . . . .	1
Ratings . . . . .	1
Options . . . . .	1
Standard Features . . . . .	1
Model Variations . . . . .	1
Safety Precautions . . . . .	1-2

---

## SECTION II INSTALLATION

Damage During Shipment . . . . .	2
Installation . . . . .	2-3
Positioning . . . . .	3
Restraining Devices . . . . .	3
Electrical Connection . . . . .	3
Gas Leak Testing . . . . .	3-4

---

## SECTION III OPERATING

Lighting . . . . .	4
Shutdown . . . . .	4
Cleaning . . . . .	4

---

## SECTION IV MAINTENANCE

Warranty Repairs . . . . .	4
Preventive Maintenance . . . . .	4

---

## SECTION V SERVICE DIAGNOSIS

General . . . . .	5
Trouble Shooting Chart . . . . .	5

---

## SECTION VI ORDERING PARTS

Ordering Parts . . . . .	5
Warning and Operating Plates . . . . .	5
Hot Plate Parts List . . . . .	6
Hot Plate Assembly . . . . .	7

---

## SECTION VII WIRING DIAGRAMS

Hot Plate Wiring and Ladder Diagrams . . . . .	8
Warranty	

# POST THIS LABEL IN A PROMINENT LOCATION ON YOUR UNIT

## **IMPORTANT**

IN THE EVENT A GAS ODOR IS DETECTED,  
SHUT DOWN UNITS AT MAIN SHUT OFF VALVE  
AND CONTACT THE LOCAL GAS COMPANY OR  
GAS SUPPLIER FOR SERVICE.



## **FOR YOUR SAFETY**

DO NOT STORE OR USE GASOLINE OR OTHER  
FLAMMABLE VAPORS OR LIQUIDS IN THE VICINITY  
OF THIS OR ANY OTHER APPLIANCE.



## **▲WARNING**

IMPROPER INSTALLATION, ADJUSTMENT,  
ALTERATION, SERVICE OR MAINTENANCE CAN  
CAUSE PROPERTY DAMAGE, INJURY OR DEATH.  
READ THE INSTALLATION, OPERATING AND  
MAINTENANCE INSTRUCTIONS THOROUGHLY  
BEFORE INSTALLING OR SERVICING THIS  
EQUIPMENT.

---

# I INTRODUCTION

---

## GENERAL

Keating MG-2 and MG-4 Hot Plates are designed to give maximum production efficiency; delivering high quality food products. The following design features are incorporated in all Keating Hot Plates.

---

## STANDARD FEATURES

- Highly polished stainless steel front
- Infinite controls
- 12" working height
- Gas and air adjustments
- Easy access for servicing
- 3/4" gas connection
- 100% factory testing

---

## RATINGS

- 15,000 BTU/hr. input per burner (natural gas and Propane)
- 4" WC (natural gas) or 10" WC (Propane) burner gas pressure
- 49 (natural gas) or 53 (Propane) burner orifice size
- 3/4" gas supply pipe recommended

---

## OPTIONS

- Natural Gas or Propane
- Spark Ignition System
- 24" or 30" depth

---

## MODEL VARIATIONS

**MG-2 Model:** The MG-2 model has two burners

**MG-4 Model:** The MG-4 model has four burners

---

## SAFETY PRECAUTIONS



### WARNING

**THIS SYMBOL WARNS YOU THAT SERIOUS BURNS OR OTHER INJURIES MAY RESULT IF SAFETY INSTRUCTIONS ARE NOT FOLLOWED.**

- This service manual should be retained in a safe place for future reference. The installation of your new hot plate must conform to local codes or in the absence of local codes, with the current National Fuel Gas Code ANSI Z223.1/NFPA 54, Natural Gas Installation Code CAN/CGA-B149.1 or Propane Installation Code CAN/CGA-B149.2.

- Your ventilation hood, when installed, must conform to the current ANSI/NFPA 96 standard.

- No frame or restriction shall be constructed around the hot plate that will restrict air movement into the hot plate's combustion area or prevent proper ventilation.

- Keating hot plates are designed to operate on the gas fuel specified on the serial plate and must not be operated with another gas fuel. They cannot be converted to another gas fuel by turning or engaging a switch.

---

**FOR YOUR SAFETY: Do not store or use gasoline or other flammable vapors and liquids in the vicinity of this or any appliance.**

You will post, in a prominent location, instructions to be followed in the event the user smells gas. This information shall be obtained from your local gas supplier. You may use the yellow stick-on label temporarily until you receive the data from your local gas supplier.

---

**IMPORTANT: In the event a gas odor is detected, shut down unit at main shut-off valve and contact the local gas company or gas supplier for emergency service.**

- Suitable for installation on combustible surfaces.
- You must maintain this appliance free and clear from combustibles.
- You must maintain the following minimum clearances from combustible and noncombustible construction:

<u>Clearances:</u>	<u>Combustible Construction</u>	<u>Noncombustible Construction</u>
Back	6"	0"
Right Side	6"	0"
Left Side	6"	0"

- You must install this appliance at least 16" away from any open flame.
- Adequate clearance for servicing and proper operation must be maintained. Your hot plate is designed to be serviced from the front.
- Keating commercial hot plates are intended for other than household use.
- ALWAYS instruct new employees on proper hot plate operation.
- A hot plate should be operated ONLY by properly trained personnel.
- ALWAYS turn hot plate off each night.
- ALWAYS disconnect fuel source before servicing.
- NEVER leave a hot plate unattended during operation.
- NEVER introduce objects into hot plate, while operational, which are not designed or made for cooking.

- THIS HOT PLATE MAY NOT BE ALTERED, MODIFIED OR CHANGED IN ANY WAY.

The State of California enacted the California Safe drinking water and Toxic Enforcement Act of 1986, (Prop.65), which “prohibits any person in the course of doing business from knowingly and intentionally exposing any individual to a chemical known to the State of California to cause cancer or reproductive toxicity without first giving clear and reasonable warning to such individuals.” The Governor’s Scientific Advisory Panel added carbon monoxide to the list of hazardous chemicals known to cause reproductive harm.

In order to establish full compliance with Proposition 65, we attached a yellow warning label to each gas fired hot plate manufactured by Keating of Chicago, Inc.

Carbon monoxide would not be present in concentrations that would pose a “significant risk” to the consumer when the equipment is installed, operated and maintained as follows:

- Installed under a properly designed operating exhausting good.
- Connected to the type of gas for which the hot plate is manufactured.
- Pressure regulator is installed in the appliance and adjusted for the manifold pressure marked on the serial plate.
- Adequate air supply to the appliance.
- In-line pressure regulator, not supplied by Keating, must be installed outside the appliance.
- The equipment is operated in the manner intended using the proper utensils.
- Keep the equipment clean and have it checked periodically.
- Burner air adjustments, mechanical maintenance and repairs must be performed by qualified service personnel.

If the equipment is not installed, operated and maintained in accordance with the above, concentrations of carbon monoxide in excess of the established limits could be present in the kitchen environment.

ALL PERSONNEL IN THE WORK PLACE WHO MAY BE SUBJECT TO ANY EXPOSURE OF CARBON MONOXIDE MUST BE WARNED OF SUCH POSSIBLE EXPOSURE. THIS WARNING SHOULD BE CONVEYED IN A MANNER SO THAT IT IS CLEARLY UNDERSTOOD BY THE EMPLOYEE, AND THE EMPLOYEE SHOULD BE ASKED IF IN FACT HE OR SHE UNDERSTANDS THE CORRECT METHOD OF OPERATION OF THE EQUIPMENT AND THAT A RISK OF EXPOSURE EXISTS IF THE EQUIPMENT IS OPERATED IMPROPERLY.



**WARNING**  
**IF NOT INSTALLED, OPERATED AND MAINTAINED IN ACCORDANCE WITH THE MANUFACTURER’S INSTRUCTIONS, THIS PRODUCT COULD EXPOSE YOU TO SUBSTANCES IN FUEL OR IN FUEL COMBUSTION WHICH CAN CAUSE DEATH OR SERIOUS ILLNESS AND WHICH ARE KNOWN TO THE STATE OF CALIFORNIA TO CAUSE CANCER, BIRTH DEFECTS OR OTHER REPRODUCTIVE HARM.**

---

## II INSTALLATION

This hot plate **MUST** be installed, inspected, and serviced by qualified and/or certified and/or licensed service personnel – you may void your Keating warranty if installation is not completed per current local, national and Keating specifications. Contact your dealer for assistance.

---

### DAMAGE DURING SHIPMENT

The hot plate has been assembled, tested and inspected at the factory. Upon arrival, the complete hot plate should be checked for any damage that may have occurred during shipment.

The carrier is responsible for all damage in transit whether visible or concealed. Do not pay for the freight bill until the hot plate has been thoroughly checked for damage. If concealed damage is found later, contact the carrier immediately to file a claim.

### What to do if equipment arrives damaged:

**VISIBLE LOSS OR DAMAGE** – Be certain to note this on the freight or express receipt and have it signed by the delivery person.

**FILE CLAIM FOR DAMAGES IMMEDIATELY** – Regardless of extent of damage.

**CONCEALED LOSS OR DAMAGE** – If damage is noticed when equipment is unpacked, notify the freight company immediately, and file a “concealed damage claim”. This **MUST** be done immediately. Be sure to retain the shipping container for inspection.

Keating does not assume responsibility for Loss OR Damage incurred in transit.

---

### INSTALLATION

Installation must conform with local codes or, in absence of local codes, with current National Fuel Gas Code ANSI Z223.1/NFPA 54, Natural Gas Installation Code CAN/CGA-B149.1 or Propane Installation Code CAN/CGA-B149.2. When pressure

testing at test pressures less than to equal to 1/2 psig (3.45 KPA), hot plate **must be isolated** from gas supply piping. When pressure testing at test pressures above 1/2 psig (3,45 KPA), hot plate **must be disconnected** from gas supply piping system.

---

## POSITIONING

The hot plate must be no closer than 6" from any combustible material and 16" away from any open flame. The hot plate must be placed under an exhaust hood with a fire retardant system. Your ventilation hood, when installed, must conform to the current ANSI/NFPA 96 standard. **ALL** connections and placement must comply with local and national codes. It is the responsibility of the owner and local installer to comply with these regulations when installing the hot plate.

---

## RESTRAINING DEVICES

Hot plates **must be restrained to prevent tipping** when installed in order to avoid splashing, spilling, etc. of hot liquid. The restraining method may be a manner of installation or by separate means. Adequate means must also be provided to limit the movement of the appliance without depending on the connector, the quick-disconnect device or its associated piping to limit the appliance movement.

Connectors must comply with the current ANSI Z21.69/CAN 1 6.10-88 standard for connectors for movable gas appliances. Quick-disconnect devices must comply with the current ANSI Z21.41/CAN 1 6.9-M79 standard for quick-disconnect devices meet these standards.



### WARNING

- **PIPE JOINT COMPOUNDS RESISTANT TO PROPANE GASES MUST BE USED.**
- **BEFORE OPERATING THIS HOT PLATE, CHECK PIPE JOINTS FOR LEAKS BY USING A SOAP AND WATER SOLUTION ONLY. DO NOT USE AN OPEN FLAME!**

Figure 2-1 Main Gas Connection

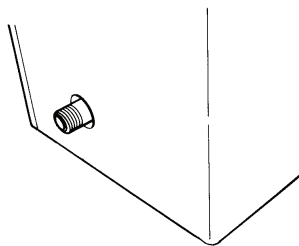

---

**FOR YOUR SAFETY: Do not store or use gasoline or other flammable vapors and liquids in the vicinity of this or any other appliance.**

Connect the hot plate to the main gas supply line at the rear of the hot plate. The piping should be a minimum of 3/4" IPS supply pipe for a single hot plate.

A 3/4" NPT manual gas valve is shipped with each single hot plate for field installation. The required gas pressure for proper operation of each hot plate is 4" water column for natural gas and 10" water column for Propane gas.

In-line pressure regulators are not supplied by Keating. They are to be provided and installed by others as directed by local codes.

---

**NOTE:** If more than one gas hot plate is on the same supply line, you may require a larger line. Consult your local gas company to assure adequate volume and pressure. Refer to serial plate for proper gas requirements for your particular model.

---

## ELECTRICAL CONNECTION

The Keating hot plate with an optional spark ignitor is equipped with a 6' neoprene covered, 3 wire electrical cord with a three-pronged grounded plug for protection against electrical shock. This plug must be placed into a 120V properly grounded three-pronged outlet. For proper grounding procedures see local codes or, in the absence of local codes, the current National Electrical Code ANSI/NFPA 70 or Canadian Electrical Code CAN 22.1 as applicable.

---

**NOTE:** For hot plates with optional spark ignitors, the electrical wiring diagram is located on the front of the control panel. Hot plates with constant pilots do not require any electrical connections.



### WARNING

**DO NOT CUT OR REMOVE THE GROUNDING PRONG FROM THIS PLUG.**

---

## GAS LEAK TESTING

Prior to lighting your hot plate:

1. Make sure all manual gas valves and gas valves (infinite controls) are in the "OFF" (fully clockwise) position.
2. Turn main ON/OFF manual gas valve to the "ON" position.
3. Have your plumber or gas company check for leaks with a soap solution. (NEVER check with a match!)
4. Have your plumber or gas company representative light the constant pilot. (Not necessary if your hot plate has an optional spark ignitor.)

 **WARNING**

**PROPANE GAS MAY EVENTUALLY LOSE ITS ODOR AND PRECAUTIONS SHOULD BE TAKEN TO ASSURE THAT IT IS NOT PRESENT EVEN THOUGH YOU DO NOT DETECT AN ODOR. IF THERE IS ANY DOUBT, YOU SHOULD CALL YOUR LOCAL PROPANE GAS SUPPLIER FOR ASSISTANCE.**

---

## III OPERATING

---

### LIGHTING

Keating hot plates are designed to provide maximum efficiency and deliver high quality food products. Follow lighting procedure below.

 **WARNING**

**OPERATION OF THIS HOT PLATE SHOULD BE LIMITED TO PERSONNEL WHO HAVE BEEN THOROUGHLY TRAINED IN OPERATING PROCEDURES.**

1. Open the manual gas valve.
2. For hot plates with constant pilots, light the constant pilot (located between the front and rear burners) with a match. For hot plates with spark ignitors, push in the red knob and rotate it fully counterclockwise until the burner ignites.

---

**CAUTION:** For hot plates with spark ignitors, rotating the red knob without holding it in may damage the gas valve (infinite switch).

---

**CAUTION:** If the pilot or burner fails to stay lit, wait five minutes before attempting to relight to allow any accumulated gas to escape.

3. For hot plates with constant pilots, rotate the red knob counterclockwise to the desired setting. For hot plates with spark ignitors, rotate the red knob clockwise to the desired setting after the burner ignites.

---

**NOTE:** The left knob operates the back burner and the right knob operates the front burner.

---

### SHUTDOWN

1. Rotate the red knob fully clockwise for each burner.

---

### CLEANING

When cleaning your hot plate, use Keating Klenzer, the finest dry stainless steel polish available, to restore your hot plate's exterior to its original luster. Keating Klenzer is USDA approved.

---

**CAUTION:** For hot plates with optional spark ignitors, disconnect the electrical power source before doing any cleaning.

---

## IV MAINTENANCE

---

### WARRANTY REPAIRS

Keating's warranty begins with the date of installation. In the event that your hot plate, under warranty, needs repairs other than routine maintenance or cleaning, you are requested to contact Keating of Chicago (at 1-800-KEATING) before calling a local service company.

---

### PREVENTIVE MAINTENANCE

Preventive maintenance should be done in daily, weekly, monthly and yearly intervals as necessary. Following preventive maintenance procedures will help keep your hot plate working efficiently. Proper care and servicing will lead to years of quality performance.

PREVENTIVE MAINTENANCE CHART			
TIME FRAME	OPERATOR/OWNER	SECTION	QUALIFIED SERVICE PERSONNEL ONLY
At Least Daily	● Check controls ● Drain and clean drip pan.	III	
		III	
At Least Weekly	● Clean hot plate.	III	
At Least Yearly*		V	● Disassemble hot plate to clean burners and orifices.

\*High production facilities should be checked more often.

## V SERVICE DIAGNOSIS

■ On constant pilot models, the pilot light will be between 3/8" to 1/2" high and burn clear blue. The constant pilot consumes about 180 BTU/hr. of gas and is used to ignite the burners.

### A. Trouble Shooting

The following diagnosis is only to be used as a guide to qualified service personnel. Keating recommends that you use a qualified service company. Call 1-800-KEATING if you need assistance in locating a qualified service company.

## VII PARTS LISTS

### ORDERING PARTS

Parts may be ordered by part number by calling Keating at 1-800-KEATING or your service company. You may also order on-line at Keating's part store, [www.keatingofchicago.com](http://www.keatingofchicago.com)

Refer to the Keating Hot Plate Limited Warranty for complete service and ordering information.

The model/serial plate is located on the front of the control panel. The serial and model numbers are necessary when ordering.

### WARNING AND OPERATING PLATES

All warning and operating plates on the Keating Hot Plate should be in a place at all times. If plates are damaged or lost, replace them immediately.

PROBLEM	PROBABLE CAUSE	SOLUTION
Constant pilot won't light.	<ul style="list-style-type: none"> <li>a. Gas isn't turned on.</li> <li>b. Clogged constant pilot orifice.</li> </ul>	<ul style="list-style-type: none"> <li>a. Turn gas valve on. If using flexible connector with quick disconnect, make sure that the quick disconnect is completely engaged.</li> <li>b. Clean the pilot orifice.</li> </ul>
Delayed ignition.	<ul style="list-style-type: none"> <li>a. Low gas supply or pressure.</li> <li>b. Low pilot flame height.</li> </ul>	<ul style="list-style-type: none"> <li>a. Verify size of incoming gas line to equipment and check gas pressure.</li> <li>b. Adjust pilot flame height. Use a qualified service company.</li> </ul>
Flames are too high.	<ul style="list-style-type: none"> <li>a. Gas valve (infinite control) set too high.</li> <li>b. Excessive gas supply or pressure.</li> <li>c. Exhaust problems.</li> </ul>	<ul style="list-style-type: none"> <li>a. Turn valve counterclockwise to decrease gas flow.</li> <li>b. Check to see if an inline regulator is present in the main gas line. Have a qualified service person adjust it and check orifices to ensure proper sizes. If an inline regulator is not present, have one installed.</li> <li>c. Contact your HVAC representative.</li> </ul>
Flames are low or come out of burner air shutter	<ul style="list-style-type: none"> <li>a. Gas valve (infinite control) set too low.</li> <li>b. Low gas supply or pressure.</li> </ul>	<ul style="list-style-type: none"> <li>a. Turn valve clockwise to increase gas flow.</li> <li>b. Verify size of incoming gas line to equipment and check gas pressure.</li> </ul>



## GAS HOT PLATE PARTS LIST

ITEM	DESCRIPTION	MG-2	MG-4	PART NUMBER
1	GAS VALVE (INFINITE CONTROL) WITH NG ORIFICE #49			
	CONSTANT PILOT	2	4	002666
	SPARK IGNITOR	2	4	002666
	ORIFICE, HOODED, NATURAL GAS, #49	2	4	002676
	GAS VALVE (INFINITE CONTROL) WITH PROPANE ORIFICE #53			
	CONSTANT PILOT	2	4	002666
	SPARK IGNITOR	2	4	002666
	ORIFICE, HOODED, PROPANE, #53	2	4	032164
2	KNOB, RED, GAS VALVE	2	4	002667
3	CONSTANT PILOT VALVE	1	2	004266
4	CONSTANT PILOT ASSEMBLY WITH ORIFICE	1	2	004259
5	CONSTANT PILOT MOUNTING BRACKET			
	24" DEEP	1	2	-----
	30" DEEP	1	2	-----
6	SPARK IGNITOR SWITCH	2	4	002666
7	SPARK IGNITOR MODULE	1	2	008934
8	SPARK ELECTRODE WITH WIRE	1	2	013899
9	SPARK ELECTRODE MOUNTING BRACKET			
	ABOVE ELECTRODE	1	2	-----
	BELOW ELECTRODE, 24" DEEP	1	2	-----
	BELOW ELECTRODE, 30" DEEP	1	2	-----
10	WORK BOX, SPARK IGNITOR MODULE	1	2	-----
11	BURNER			
	FRONT, 24" DEEP	1	2	006464
	FRONT, 30" DEEP	1	2	002651
	REAR, 24" DEEP	1	2	006465
	REAR, 30" DEEP	1	2	006466
12	PRESSURE REGULATOR			
	NATURAL GAS	1	2	004236
	PROPANE	1	2	023527
13	CORD WITH PLUG, 6', 16/3 SJO FOR SPARK IGNITOR			
	WITH WIRING HARNESS FOR MG-2	1		-----
	CORD WITH PLUG ONLY	1	1	006315
	WIRE HARNESS ONLY	1	2	-----
14	CONDUIT, 1/2" (SPECIFY FOR 24" OR 30" DEEP)	1	2	-----
15	BUSHING, STRAIN RELIEF	1	2	000470
16	CONDUIT CONNECTOR, 1/2"	2	4	-----
17	BURNER GRATE	2	4	002674
18	GRATE DIVIDER			
	MG-2, 24" DEEP	1		014601
	MG-2, 30" DEEP	1		007895
	MG-4, 24" DEEP		1	014602
	MG-4, 30" DEEP		1	008933
19	CONTROL PANEL			
	MG-2	1		-----
	MG-4		1	-----
20	DRIP PAN ASSEMBLY			
	MG-2 24/30, MG-4 24	1	2	018548
	MG-4 30	1	2	019086
21	GRATE SEPARATOR, MG-4		2	002663



# VIII WIRING DIAGRAMS

## MG SI WIRING AND LADDER DIAGRAMS

The diagrams below apply to hot plates with spark ignition ("SI"). Hot plates with constant pilots ("CP") do not have any electrical connections.

**NOTE:** MG-4 hot plates are essentially two MG-2 hot plates side by side. Each cabinet half has its own spark module, electrode and ignitor switches.

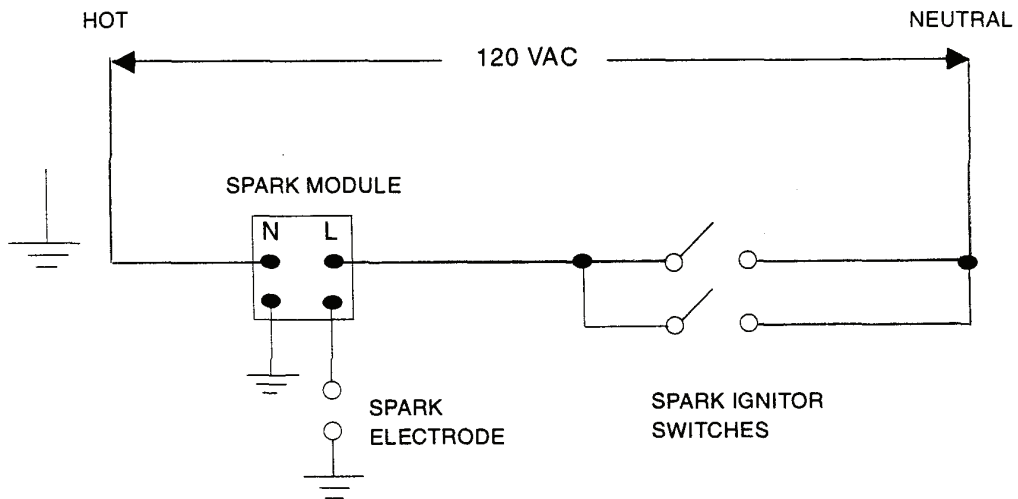
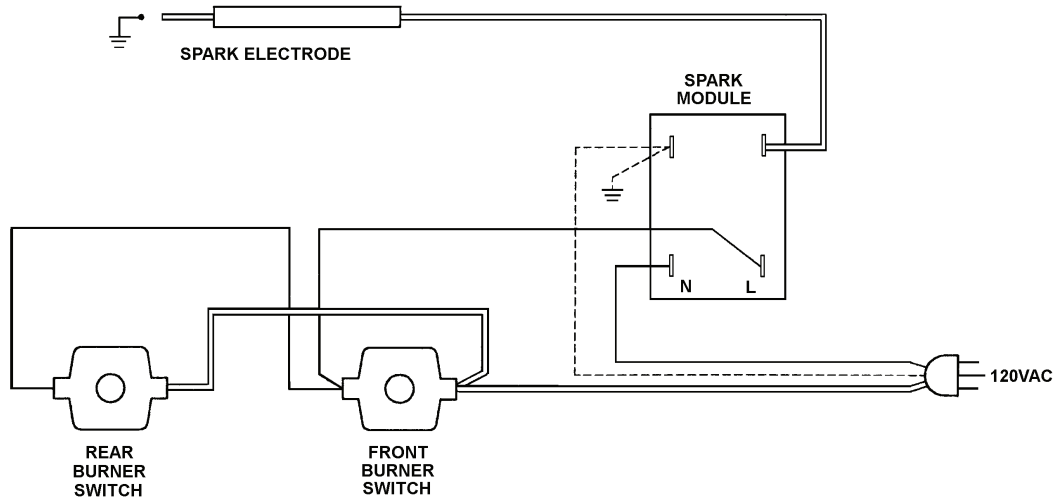



# WARRANTY

## LIMITED WARRANTY

Keating Of Chicago, Inc. ("Keating") warrants to the original purchaser. ("Customer"), all new Keating Fryers, Filter Systems, Griddles, Keep Krisp®, Custom Pasta Systems, Top-Side™ Cookers, Computer Timers, Fryer & Pasta Vessels, and Keating replacement parts ("products") installed after June 1, 1994 to be free to defects in material or workmanship, subject to the following terms and conditions.

## LENGTH OF WARRANTY

All products other than Fryer & Pasta Vessels and replacement parts shall be warranted for a period of one year from the date of original equipment installation. Keating replacement parts are warranted for a period of ninety days from the date of installation. Fryer & Pasta Vessels are warranted as described below.

## FRYER & PASTA VESSEL WARRANTY

Fryers purchased after June 1, 1994 carry a prorated vessel warranty on defects in materials or workmanship to the Customer based on the following scale:

Time from Installation Date	Fryer Vessel Warranty Credit
13-60 months	100%
61-72 months	80%
73-84 months	60%
85-96 months	40%
97-108 months	20%
109-120 months	10%

The credit for the defective fryer & pasta vessel shall be applied against the cost of the replacement vessel, utilizing Keating's then current price, upon return of the vessel to Keating, (Freight to be paid by Keating within the first 2 months only), only during the first 60 months as described above, subject to the limitations described below.

## LIMITATIONS OF LIABILITY

In the event of warranty claim or otherwise, the sole obligation of Keating shall be the repair and/or replacement at the option of Keating of the product or component or part thereof. Such repair or replacement shall be at the expense of Keating except that the Customer shall pay the following expenses: all freight and labor expense for Keating replacement parts for all other products, mileage exceeding 50 miles or travel more than one hour, labor costs of more than one person, overtime rates, truck charges, difference between ground and other mode of transportation, and holiday charges. Any repair or replacement under this Limited Warranty does not constitute an extension of the original warranty for any period for the product or for any component or part thereof. Parts to be replaced under this Limited Warranty will be repaired at the option of Keating with new or functionally operative parts. Keep Krisps and Computer Timers must be returned to Keating for warranty repair or replacement. Field repairs of those items are not authorized.

THE LIABILITY OF KEATING ON ANY CLAIM OF ANY KIND, INCLUDING CLAIMS BASED ON WARRANTY, EXPRESSED OR IMPLIED, CONTRACT, NEGLIGENCE, STRICT LIABILITY OR ANY OTHER THEORIES SHALL BE SOLELY AND EXCLUSIVELY THE REPAIR OR REPLACEMENT OF THE PRODUCT AS STATED HEREIN, AND SUCH LIABILITY SHALL NOT INCLUDE, AND CUSTOMER SPECIFICALLY RENOUNCES ANY RIGHTS TO RECOVER, SPECIAL, INCIDENTAL, CONSEQUENTIAL OR OTHER INJURIES TO PERSONS OR DAMAGE TO PROPERTY, LOSS OF PROFITS OR ANTICIPATED PROFITS, OR LOSS OF USE OF THE PRODUCT.

If any oral statements have been made regarding the Keating products, such statements do not constitute warranties and are not part of the contract sale. This Limited Warranty constitutes the complete, final and exclusive statement with regard to warranties.

THIS LIMITED WARRANTY IS EXCLUSIVE AND IS IN LIEU OF ALL OTHER WARRANTIES WHETHER WRITTEN, ORAL, STATUTORY OR IMPLIED, INCLUDING BUT NOT LIMITED TO ANY WARRANTY OF MERCHANTABILITY OR FITNESS FOR PARTICULAR PURPOSE OR WARRANTY AGAINST LATENT DEFECTS.

The warranties provided by Keating of Chicago, Inc. do not apply in the following instances:

1. Defects arising out of or resulting from improper installation or maintenance, abuse, misuse, modification or alteration by unauthorized service personnel, or any other condition not attributable to a defect in material or workmanship. Proper installation and maintenance are the responsibility of the installer and Customer, respectively. Proper installation and maintenance procedures are prescribed by the Keating Service Manual.
2. In the event that the product was damaged after leaving the factory due to flood, fire, other acts of God or accident, damage during shipment should be reported to the carrier and is not the responsibility of Keating.
3. In the event the serial number or rating plate has been removed from the product or altered.
4. On parts which would normally be worn or replaced under normal conditions, including but not limited to electric bulbs, fuses, interior and exterior finishes, gaskets and radiants.
5. With regard to adjustments and calibrations such as leveling, tightening of fasteners or plumbing connections, improper gas pressure or improper electrical supply, the checking of and changes in adjustment and calibrations are the responsibility of the installer. Proper installation procedures are prescribed by the Keating Service Manual.
6. In the event of unauthorized repairs or alterations to the Keating product.
7. With the use of sodium chloride in pasta vessels or harsh chemicals in fryer or pasta vessels.

The Customer must provide proof of purchase from Keating.

This Limited Warranty is valid in the 50 United States, its territories, and Canada, and is void elsewhere.

Keating products are sold for commercial use only. If any Keating product is sold as a component of another product or used as a consumer product, such Keating product is sold As Is without any warranty.

If any provision of this Limited Warranty is held to be unenforceable under the law of any jurisdiction, such provision shall be unenforceable in such jurisdiction, and the remainder of the warranty shall remain unaffected.

Further in such event, the maximum exclusion or limitation allowable under applicable law shall be deemed substituted for the unenforceable provision.

This Limited Warranty shall be governed by and construed in accordance with the laws of the State of Illinois.

## TO SECURE WARRANTY SERVICE

All repair services under this Limited Warranty must be authorized by Keating or performed at Keating. Authorization may be obtained by calling 1-800-KEATING within the Continental United States, Alaska, Hawaii, Puerto Rico and Canada during normal business hours (7:00 a.m. through 6:00 p.m. Central Time, Monday through Friday). When calling, please have the following information available: (1) name, address and telephone number of the Customer; (2) location of product, if different; (3) name, model number and serial number of the product; (4) installation date; and (5) description of defect. Keating will then issue a service authorization work order number to one of its approved independent servicing organizations, or request the product or part be shipped to Keating for repair or replacement, as appropriate. Any defective part subject to a claim under this Limited Warranty must be shipped freight prepaid to Keating for testing and examination. Keating's decision as to the cause and nature of any defect under this Limited Warranty shall be final.

## KEATING

KEATING OF CHICAGO, INC., 1-800-KEATING [WWW.KEATINGOFCHICAGO.COM](http://WWW.KEATINGOFCHICAGO.COM)

REF/E/warranty 807

**SERVICE INFORMATION**

If you have a service related question call 1-800-KEATING.

Please state the nature of the call; it will ensure speaking with the appropriate person.

Have your serial and model number available when ordering parts.

**KEATING OF CHICAGO, INC.**

8901 W. 50th Street, McCook, Illinois 60525-6001

Phone: (708) 246-3000 FAX: (708) 246-3100

Toll Free 1-800-KEATING (In U.S. and Canada)

www.keatingofchicago.com

*\*As continuous product improvement occurs, specifications may be changed without notice.*

**KEATING LIMITED WARRANTY CARD**

PLEASE COMPLETE AND MAIL AT ONCE--WARRANTY IS NOT IN EFFECT UNTIL CARD IS RETURNED

COMPANY: \_\_\_\_\_

ADDRESS: \_\_\_\_\_

CITY: \_\_\_\_\_ STATE: \_\_\_\_\_ ZIP: \_\_\_\_\_

DEALER: \_\_\_\_\_

DATE OF PURCHASE: \_\_\_\_\_ INVOICE NUMBER: \_\_\_\_\_

SERIAL NUMBER: \_\_\_\_\_  FRYER  FILTER SYSTEM  GRIDDLE

REMARKS: \_\_\_\_\_  TOP-SIDE COOKER  HOT PLATE  PASTA PLUS

I HAVE READ THE INSTALLATION AND OPERATION INSTRUCTIONS.

SIGNED: \_\_\_\_\_ DATE: \_\_\_\_\_

*Serving Those Who Serve The Very Best*