



JOHN DEERE

1.7-5 METRIC TON

ZTS

EXCAVATORS

17ZTS | 27C ZTS | 35C ZTS | 50C ZTS



ZERO TAIL SWING



Don't bust your tail.

Get a Deere ZTS Excavator instead. Their state-of-the-art design allows these nimble compacts to rotate fully without banging their tails into something. Combined with independent-swing boom and 360-degree rotation, they slip into close quarters comfortably. And work with ease around critical structures and other obstacles.

It's not just their shape and small stature that make these excavators such valuable assets. Standard equipped with quick-coupler and auxiliary hydraulics, plus any of the many optional Worksite Pro™ attachments, the ZTS Excavators are highly capable compacts. And perfect for a wide variety of work.



These compacts won't cramp your style. **Wide control spacing and adjustable seats** provide daylong comfort for any operator. Optional suspension seat available.

Independent-swing boom and 360-degree rotation enable you to position yourself to do more work.

Rubber tracks traverse virtually any terrain and are especially welcome on paved surfaces. Steel tracks and rubber crawler pads are also available.

- 1. Control pattern selector valve** easily accommodates operator preferences. Go from backhoe- to excavator-style controls with just a turn of a dial.
- Easy-to-read and conveniently located, the **systems monitor** keeps you advised of vital operating information.
- You won't bust your tail maintaining a ZTS Excavator, either. **All doors open wide**, providing easy access to daily service points, cooling system, fuel filters, and battery.
- Ergonomically correct, low-effort pilot controls** direct an open-center variable-displacement hydraulic system for smooth, combined-function performance. So even unfamiliar operators become proficient quickly.
- Perhaps best of all, the ZTS Excavators are backed by Deere's **12-month warranty**, extensive preventive maintenance programs, and nationwide dealer network.



1



2



3



4



5

It's not just the ZTS Excavators' "off-the-wall" design that opens up new opportunities for you. Armed with **quick-coupler and auxiliary hydraulics**, their possibilities are almost endless.

Manual quick-coupler makes fast work of bucket and attachment switchover. Add any of the many buckets and Worksite Pro™ attachments and watch utilization take off.

Bust through blacktop, concrete, or other hard surfaces with a **Worksite Pro™ breaker**. Available front screen is recommended when using breaker.

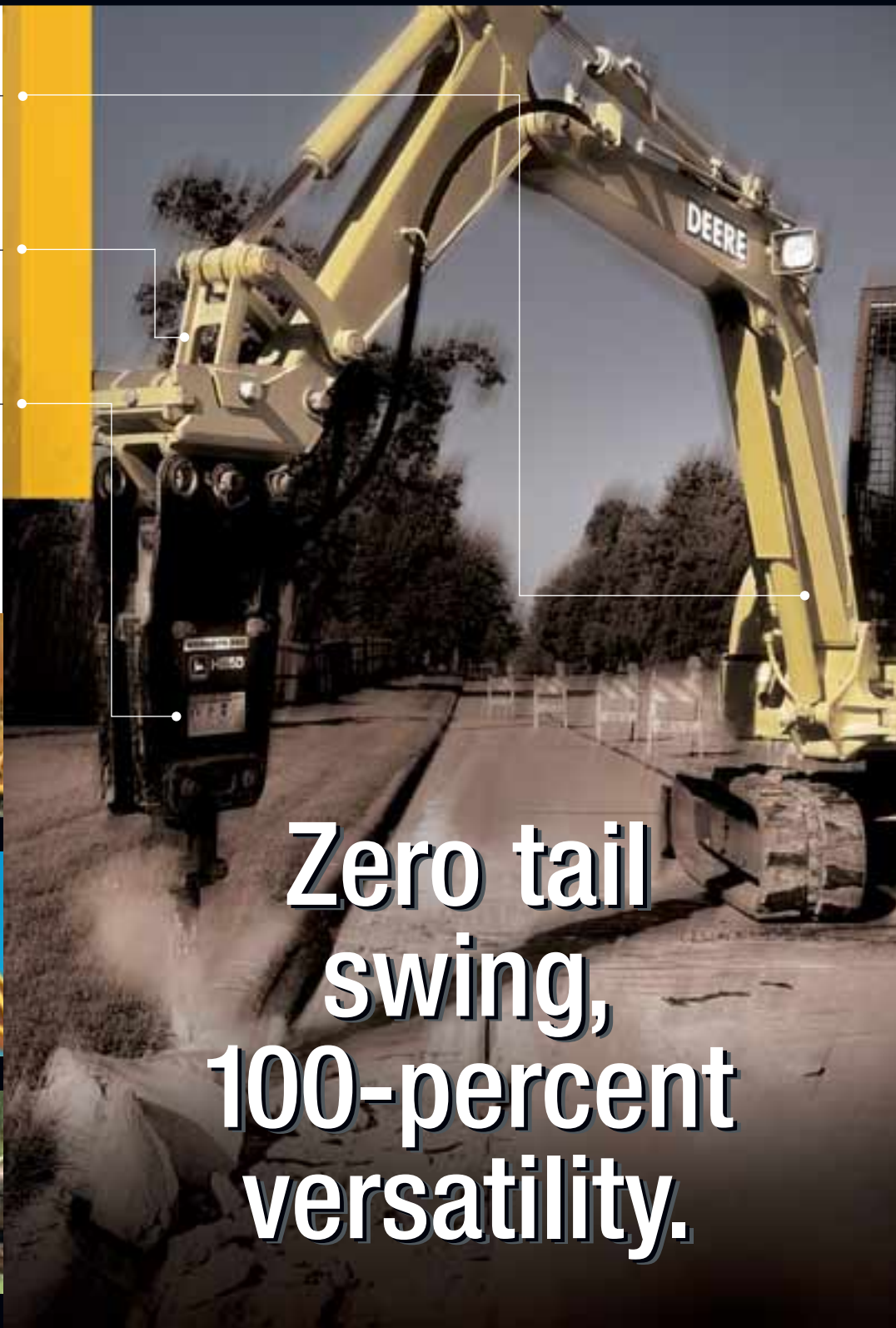

1. Ditch-cleaning buckets from 30 to 36 inches wide handle loose or mucky materials. Cutting edges are replaceable.

2. Boom-mounted auxiliary hydraulic lines and a return-flow selector valve accommodate both one- and two-way hydraulically driven attachments.

3. Rake/clamp combo works well for clearing jobs and light demolition work.

4. Worksite Pro™ augers can be equipped with rock, heavy-duty, standard, and tree and shrub bits.

5. Heavy-duty quick-coupler trenching buckets range from 9 to 30 inches wide. Teeth are replaceable.

6. Add a hydraulic clamp and use it with the bucket for handling cumbersome objects.



ATTACHMENTS

	17ZTS	27C ZTS	35C ZTS	50C ZTS
9-in. (0.6 cu. ft.) heavy-duty quick-coupler bucket	●			
12-in. (1.5 cu. ft.) heavy-duty quick-coupler bucket	●	●		
12-in. (1.7 cu. ft.) heavy-duty quick-coupler bucket			●	
12-in. (2.1 cu. ft.) heavy-duty quick-coupler bucket				●
16-in. (2.1 cu. ft.) heavy-duty quick-coupler bucket	●	●		
16-in. (2.4 cu. ft.) heavy-duty quick-coupler bucket			●	
18-in. (1.4 cu. ft.) heavy-duty quick-coupler bucket	●			
18-in. (3.6 cu. ft.) heavy-duty quick-coupler bucket				●
20-in. (2.8 cu. ft.) heavy-duty quick-coupler bucket		●		
20-in. (3.2 cu. ft.) heavy-duty quick-coupler bucket			●	
24-in. (3.4 cu. ft.) heavy-duty quick-coupler bucket		●		
24-in. (4.0 cu. ft.) heavy-duty quick-coupler bucket			●	
24-in. (5.2 cu. ft.) heavy-duty quick-coupler bucket				●
30-in. (4.4 cu. ft.) ditch-cleaning quick-coupler bucket		●		
30-in. (5.2 cu. ft.) heavy-duty quick-coupler bucket			●	
30-in. (6.8 cu. ft.) heavy-duty quick-coupler bucket				●
34-in. (5.9 cu. ft.) ditch-cleaning quick-coupler bucket			●	
36-in. (8.3 cu. ft.) ditch-cleaning quick-coupler bucket				●
Hydraulic clamp	●	●	●	●
16-in. quick-coupler rake	●			
22-in. quick-coupler rake		●		
26-in. quick-coupler rake			●	
30-in. quick-coupler rake				●

WORKSITE PRO™ ATTACHMENTS

	17ZTS	27C ZTS	35C ZTS	50C ZTS
HB15 hydraulic breaker (150-ft./lb. impact energy)	●	●		
HB30 hydraulic breaker (300-ft./lb. impact energy)		●	●	
HB50 hydraulic breaker (500-ft./lb. impact energy)		●	●	●
HB75 hydraulic breaker (750-ft./lb. impact energy)			●	●
CA15 chain-drive hydraulic auger	●	●		
CA25 chain-drive hydraulic auger		●	●	
PA15 planetary-drive hydraulic auger	●	●		
PA30 planetary-drive hydraulic auger			●	●

Many Worksite Pro™ attachments are also compatible with John Deere 200 Series Skid Steers and the 110 Tractor Loader Backhoe. See your dealer for details.



Specifications

17ZTS | 27C ZTS | 35C ZTS | 50C ZTS

Engine	17ZTS	27C ZTS	35C ZTS	50C ZTS
Make	Isuzu	Isuzu	Isuzu	Isuzu
Model	3YB1	3LD2	3LD2	4LE2
Fuel	Diesel	Diesel	Diesel	Diesel
Cooling	Liquid	Liquid	Liquid	Liquid
Displacement	46.4 cu. in. (0.76 L)	91.5 cu. in. (1.50 L)	91.5 cu. in. (1.50 L)	133.0 cu. in. (2.18 L)
Horsepower	12.3 hp (9.2 kW) @ 2,300 rpm	32.0 hp (23.5 kW) @ 2,450 rpm	32.0 hp (23.5 kW) @ 2,450 rpm	41.5 hp (30.5 kW) @ 2,200 rpm

Performance

Operating Weight	3,814 lb. (1730 kg)	6,482 lb. (2940 kg)	7,760 lb. (3520 kg)	10,252 lb. (4650 kg)
Maximum Travel Speed				
Low	1.2 mph (2.0 km/h)	1.5 mph (2.4 km/h)	2.0 mph (3.2 km/h)	1.6 mph (2.5 km/h)
High	2.5 mph (4.0 km/h)	2.5 mph (4.0 km/h)	2.8 mph (4.5 km/h)	2.7 mph (4.4 km/h)
Hydraulic Pumps	3 total	3 total	3 total	1 total
Type	2 piston and 1 gear	2 piston and 1 gear	2 piston and 1 gear	1 piston
Total Capacity				
Piston	4.4 gpm (16.8 L/min.) x 2	8.2 gpm (31.0 L/min.) x 2	10.8 gpm (40.8 L/min.) x 2	29.1 gpm (110.0 L/min.)
Gear	3.3 gpm (12.5 L/min.)	4.4 gpm (16.8 L/min.)	7.1 gpm (26.8 L/min.)	N/A
Auxiliary Flow	7.7 gpm (29.3 L/min.)	12.6 gpm (47.8 L/min.)	17.9 gpm (67.6 L/min.)	22.5 gpm (85.2 L/min.)
Fuel Tank Capacity	6.6 gal. (25 L)	10.5 gal. (40 L)	10.5 gal. (40 L)	13.2 gal. (50 L)
Hydraulic Tank Capacity	7.4 gal. (28 L)	7.9 gal. (30 L)	7.9 gal. (30 L)	11.8 gal. (45 L)
Ground Pressure (With Rubber Track)	29.9 kPa (4.34 psi)	26.0 kPa (3.80 psi)	30.0 kPa (4.40 psi)	26.0 kPa (3.80 psi)

Lift Capacities

Ground Level at 10-ft. (3.05 m)				
Radius				
Over Front, Blade Down	864 lb. (392 kg)*	2,146 lb. (973 kg)*	2,865 lb. (1300 kg)*	5,190 lb. (2354 kg)*
Over Side	470 lb. (213 kg)	960 lb. (435 kg)	1,455 lb. (660 kg)	2,151 lb. (976 kg)

*Limited by hydraulics.

Drive

Each track is independently driven by a hydrostatic axial-piston motor connected to a two-stage planetary gear reduction box.

Swing System

Swing Speed	8.6 rpm	8.9 rpm	8.9 rpm	9.0 rpm
Boom Swing				
Left	65 degrees	66 degrees	66 degrees	60 degrees
Right	50 degrees	66 degrees	66 degrees	80 degrees

Blade

Blade Width	4 ft. 5.0 in. (1350 mm)	5 ft. 1.0 in. (1550 mm)	5 ft. 8.5 in. (1740 mm)	6 ft. 6.7 in. (2000 mm)
Blade Height	10.5 in. (270 mm)	15.2 in. (385 mm)	15.2 in. (385 mm)	15.2 in. (385 mm)

Working Range	17ZTS	27C ZTS	35C ZTS	50C ZTS
Transport Length	12 ft. 0 in. (3660 mm)	13 ft. 11 in. (4260 mm)	15 ft. 5 in. (4720 mm)	17 ft. 5 in. (5330 mm)
Arm Length	3 ft. 1 in. (930 mm)	3 ft. 10 in. (1170 mm)	4 ft. 2 in. (1265 mm)	4 ft. 5 in. (1340 mm)
A Maximum Digging Height	11 ft. 7 in. (3530 mm)	13 ft. 11 in. (4240 mm)	14 ft. 8 in. (4470 mm)	18 ft. 6 in. (5640 mm)
B Maximum Dumping Height	8 ft. 4 in. (2550 mm)	9 ft. 10 in. (3000 mm)	10 ft. 2 in. (3100 mm)	12 ft. 11 in. (3950 mm)
C Maximum Digging Depth	7 ft. 3 in. (2200 mm)	8 ft. 8 in. (2650 mm)	10 ft. 4 in. (3150 mm)	11 ft. 10 in. (3600 mm)
D Maximum Digging Reach	12 ft. 11 in. (3950 mm)	15 ft. 5 in. (4700 mm)	17 ft. 1 in. (5210 mm)	19 ft. 0 in. (5800 mm)
E Minimum Front Swing Radius	5 ft. 5 in. (1655 mm)	6 ft. 8 in. (2040 mm)	7 ft. 9 in. (2360 mm)	6 ft. 11 in. (2100 mm)
Bucket Breakout Force	3,042 lb. (1380 kg)	5,071 lb. (2300 kg)	6,173 lb. (2800 kg)	8,378 lb. (3800 kg)
Arm Breakout Force	2,138 lb. (970 kg)	3,329 lb. (1510 kg)	4,299 lb. (1950 kg)	5,512 lb. (2500 kg)

Dimensions

F Upperstructure Width	4 ft. 5 in. (1350 mm)	4 ft. 11 in. (1490 mm)	4 ft. 11 in. (1490 mm)	6 ft. 1 in. (1870 mm)
G Overall Height	7 ft. 7 in. (2320 mm)	8 ft. 4 in. (2550 mm)	8 ft. 5 in. (2570 mm)	8 ft. 7 in. (2610 mm)
H Track Width	9 in. (230 mm)	12 in. (300 mm)	12 in. (300 mm)	16 in. (400 mm)
I Undercarriage Width	4 ft. 5 in. (1350 mm)	5 ft. 1 in. (1550 mm)	5 ft. 9 in. (1740 mm)	6 ft. 7 in. (2000 mm)
J Ground Clearance	9.4 in. (240 mm)	1 ft. 1.8 in. (325 mm)	1 ft. 1.8 in. (325 mm)	1 ft. 1.2 in. (335 mm)
K Tail Swing Radius	2 ft. 3.0 in. (675 mm)	2 ft. 7.0 in. (775 mm)	2 ft. 10.0 in. (870 mm)	3 ft. 3.4 in. (1000 mm)
L Engine Cover Height	4 ft. 2 in. (1265 mm)	4 ft. 11 in. (1510 mm)	5 ft. 0 in. (1530 mm)	5 ft. 2 in. (1580 mm)
M Maximum Blade Lift Above Ground	10.7 in. (275 mm)	1 ft. 1 in. (330 mm)	1 ft. 3 in. (380 mm)	1 ft. 4 in. (400 mm)
N Maximum Blade Drop Below Ground	9.8 in. (250 mm)	1 ft. 2.6 in. (370 mm)	1 ft. 4.0 in. (400 mm)	1 ft. 2.0 in. (365 mm)
O Sprocket Center To Idler Center	4 ft. 0 in. (1210 mm)	4 ft. 11 in. (1500 mm)	5 ft. 7 in. (1700 mm)	6 ft. 5 in. (1960 mm)
P Track Length	5 ft. 2 in. (1570 mm)	6 ft. 4 in. (1920 mm)	6 ft. 11 in. (2120 mm)	8 ft. 0 in. (2450 mm)
Q Counterweight Clearance	1 ft. 6 in. (455 mm)	1 ft. 9 in. (540 mm)	1 ft. 10 in. (555 mm)	2 ft. 0 in. (600 mm)

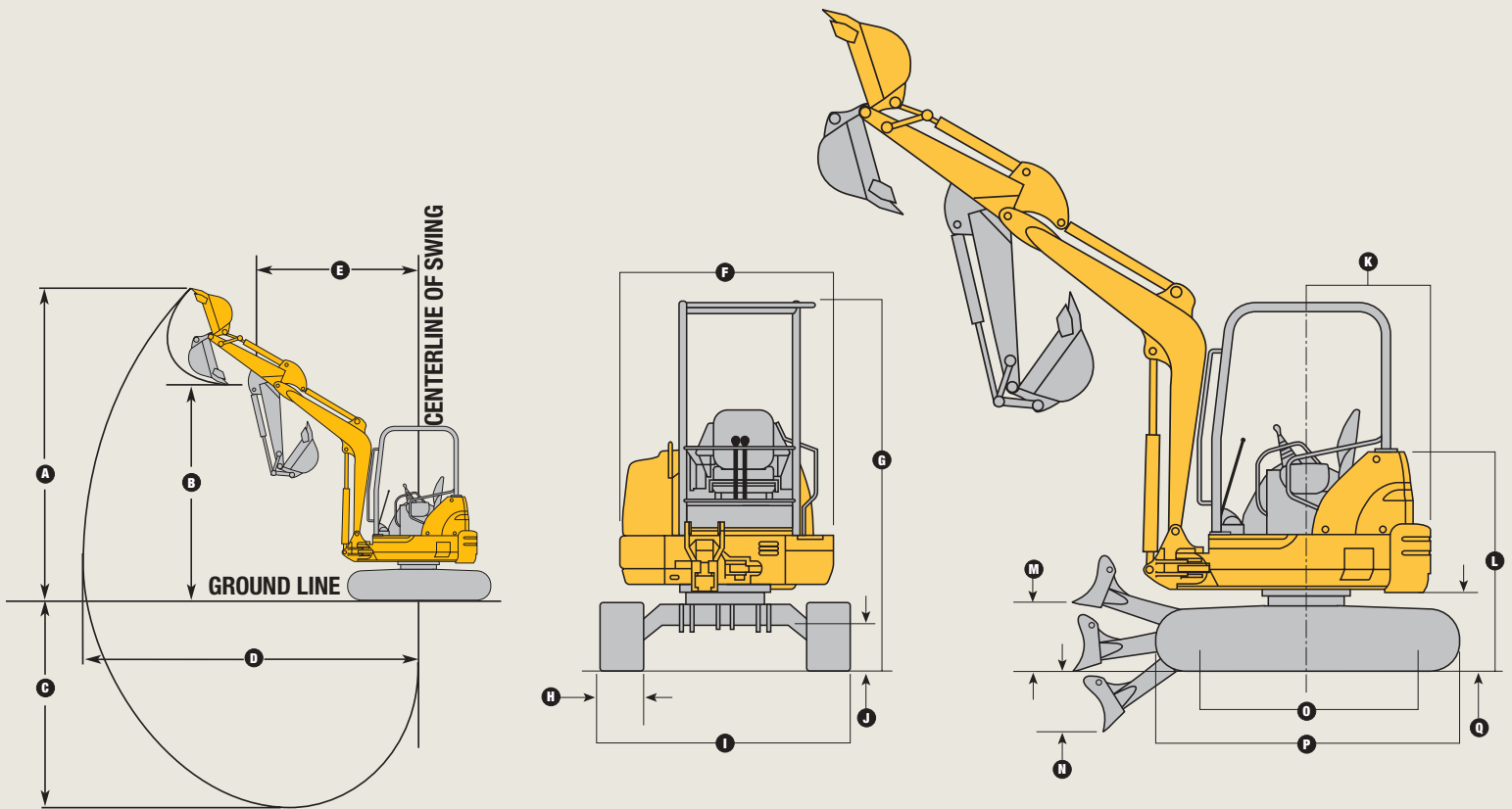

17ZTS / 27C ZTS / 35C ZTS / 50C ZTS COMPACT EXCAVATORS

Key: ● Standard equipment ▲ Optional or special equipment

See your John Deere dealer for further information.

17	27	35	50	Engine
●	●	●	●	Engine coolant to -34°F (-37°C)
●	●	●	●	Engine preheater
●	●	●	●	Meets EPA Tier II non-road emissions regulations
●	●	●	●	Fan guard
●	●	●	●	Fuel/water separator
●	●	●	●	Full-flow oil filter
●	●	●	●	Isolation mounted
●	●	●	●	Key start switch with electric fuel shutoff
●	●	●	●	Single dry-type air filter
●	●	●	●	Under-hood muffler

Hydraulic System				
●	●	●	●	Auxiliary function foot control
●	●	●	●	Auxiliary hydraulic lines with quick-couplers to end of boom
●	●	●	●	Auxiliary return-flow selector valve
●	●	●	●	Axial-piston swing motor
●	●	●	●	Boom-swing foot control
●	●	●	●	Excavator-to-backhoe control pattern change valve
●	●	●	●	Open center with two variable-displacement pumps and one fixed-gear pump
●	●	●	●	Closed center load sensing with one variable-displacement and one fixed-gear pump
●	●	●	●	Hydraulic pilot controls for boom, arm, bucket, swing, boom swing, blade, and auxiliary functions
●	●	●	●	Wet-disc swing brake

Undercarriage				
●	●	●	●	Planetary final drive
●	●	●	●	Propel motor shield
●				Rubber track, 9 in. (230 mm)
	●	●		Rubber track, 12 in. (300 mm)
			●	Rubber track, 16 in. (400 mm)
●	●	●	●	Two-speed axial-piston propel motors

17	27	35	50	Undercarriage (continued)
▲				Steel track, 9 in. (230 mm) with triple semi-grousers
	▲	▲		Steel track, 12 in. (300 mm) with triple semi-grousers
			▲	Steel track, 16 in. (400 mm) with triple semi-grousers
	▲	▲		Rubber crawler pad, 11.8 in. (300 mm)
			▲	Rubber crawler pad, 15.7 in. (500 mm)

Upperstructure				
●	●	●	●	360-degree rotation
●				Counterweight, 672 lb. (305 kg)
	●			Counterweight, 659 lb. (299 kg)
		●		Counterweight, 1,257 lb. (570 kg)
			●	Counterweight, 1,323 lb. (600 kg)
●	●	●	●	Hinged service-access doors
●				Independent-swing boom (65-degree left, 50-degree right)
	●	●		Independent-swing boom (66-degree left, 66-degree right)
			●	Independent-swing boom (60-degree left, 80-degree right)
●	●	●	●	Toolbox
●	●	●	●	TOPS/FOPS canopy
●	●	●	●	Vandal locks for service doors, fuel cap, toolbox, and monitor panel
●	●	●	●	Zero-tail-swing configuration

Front Attachments				
●				Arm, 3 ft. 1.0 in. (930 mm)
	●			Arm, 3 ft. 10.0 in. (1170 mm)
		●		Arm, 4 ft. 2.0 in. (1265 mm)
			●	Arm, 4 ft. 5.0 in. (1340 mm)
●	●	●	●	Articulation hose shield
●				Backfill blade, 4 ft. 4 in. (1350 mm)
	●			Backfill blade, 5 ft. 1 in. (1550 mm)
		●		Backfill blade, 5 ft. 8.5 in. (1740 mm)
			●	Backfill blade, 6 ft. 7 in. (2000 mm)
●	●			Boom, 6 ft. 10.5 in. (2100 mm)
			●	Boom, 8 ft. 0.5 in. (2450 mm)
			●	Boom, 9 ft. 2 in. (2800 mm)

17	27	35	50	Front Attachments (continued)
●	●	●	●	Mechanical quick-coupler
▲	▲	▲	▲	Augers: Planetary / Chain drive / Bits / Bit adapters
▲	▲	▲	▲	Brush rake
▲	▲	▲	▲	Clamp
▲	▲	▲	▲	Hammers: Points / Tools
▲	▲	▲	▲	Quick-coupler buckets: Bucket teeth / Ditching / Heavy-duty

Operator's Station				
●	●	●	●	Horn
●	●	●	●	Hourmeter
●	●	●	●	Instrumentation lights
●	●	●	●	Monitor system: Preheat indicator / Engine oil pressure indicator / Alternator voltage indicator / Fuel gauge and fuel level indicator / Engine coolant temperature gauge and engine coolant temperature indicator / Hourmeter / Operating lights indicator / Operating lights switch
●	●	●	●	Motion alarm with cancel switch
●	●	●	●	Propel pedals and levers
●	●	●	●	Two travel modes with foot selection switch
●	●	●	●	Seat belt, 2 in. (51 mm), retractable
●	●	●	●	Vinyl seat with fore/aft adjustment
	▲	▲	▲	Cab with air conditioning
	▲	▲	▲	Cab with heater
▲	▲	▲	▲	Front screen
	▲	▲		Rear secondary exit kit
	▲	▲	▲	Suspension seat

Electrical				
●	●	●	●	12-volt accessory outlet
●	●	●	●	Alternator, 35 amp
●	●	●	●	Low-maintenance battery
●	●	●	●	Blade-type multi-fused circuits
●	●	●	●	Positive-terminal battery covers

Lights				
●	●	●	●	Work lights: Halogen / One mounted on frame / One mounted on boom

CONTROL OWNING AND OPERATING COSTS

Customer Personal Service (CPS) is part of John Deere's proactive, fix-before-fail strategy on machine maintenance that will help control costs, increase profits, and reduce stress. Included in this comprehensive lineup of ongoing programs, and services are:

Fluid analysis program—tells you what's going on inside *all* of your machine's major components so you'll know if there's a problem *before* you see a decline in performance. Fluid analysis is included in most extended coverage and preventive-maintenance agreements.

Component life-cycle data—gives you vital information on the projected life span of components and lets you make informed decisions on machine maintenance by telling you approximately how many hours of use you can expect from an engine, transmission, or hydraulic pump. This information can be used to preempt catastrophic downtime by servicing major components at about 80 percent of their life cycle.

Preventive Maintenance (PM) agreements—give you a fixed cost for maintaining a machine for a given period of time. They also help you avoid downtime by ensuring that critical

maintenance work gets done right and on schedule. On-site preventive maintenance service performed where and when you need it helps protect you from the expense of catastrophic failures and lets you avoid waste-disposal hassles.

Extended coverage—gives you a fixed cost for machine repairs for a given period of time so you can effectively manage costs. Whether you work in a severe-service setting or just want to spread the risk of doing business, this is a great way to custom-fit coverage for your operation. And an extended coverage contract also travels well because it's backed by John Deere and is honored by *all* Deere construction dealers.

Customer Support Advisors (CSAs)—Deere believes the CSA program lends a *personal* quality to Customer Personal Service (CPS). Certified CSAs have the knowledge and skills for helping make important decisions on machine maintenance and repair. Their mission is to help you implement a plan that's right for *your* business and take the burden of machine maintenance off your shoulders.



Net engine power is with standard equipment including air cleaner, exhaust system, alternator, and cooling fan, at standard conditions per SAE J1349 and DIN 6270B, using No. 2-D fuel at 35 API gravity. No derating is required up to 6,600-ft. (2000 m) altitude. Gross power is without cooling fan.

Specifications and design subject to change without notice. Wherever applicable, specifications are in accordance with SAE standards. Except where otherwise noted, these specifications are based on a canopy unit with full fuel tank and 175-lb. (79 kg) operator; 17ZTS unit with 17.7-in. (450 mm), 1.5-cu. ft. (0.04 m³) bucket, 9-in. (230 mm) rubber track, and 672-lb. (305 kg) counterweight; 27C ZTS unit with 20-in. (508 mm), 2.8-cu. ft. (0.08 m³) bucket, 12-in. (300 mm) rubber track, and 659-lb. (299 kg) counterweight; 35C ZTS unit with 24-in. (610 mm), 4.0-cu. ft. (0.11 m³) bucket, 12-in. (300 mm) rubber track, and 1,257-lb. (570 kg) counterweight; and 50C ZTS unit with 24-in. (610 mm), 5.7-cu. ft. (0.16 m³) bucket, 16-in. (400 mm) rubber track, and 1,323-lb. (600 kg) counterweight. Lift capacities shown are for base machine above with mechanical quick-coupler, less bucket.

