

Diamond®



SNOWPLOWS

by Meyer

Out-Front-Electric Hydraulics

Owner's Manual

Diamond Snowplows

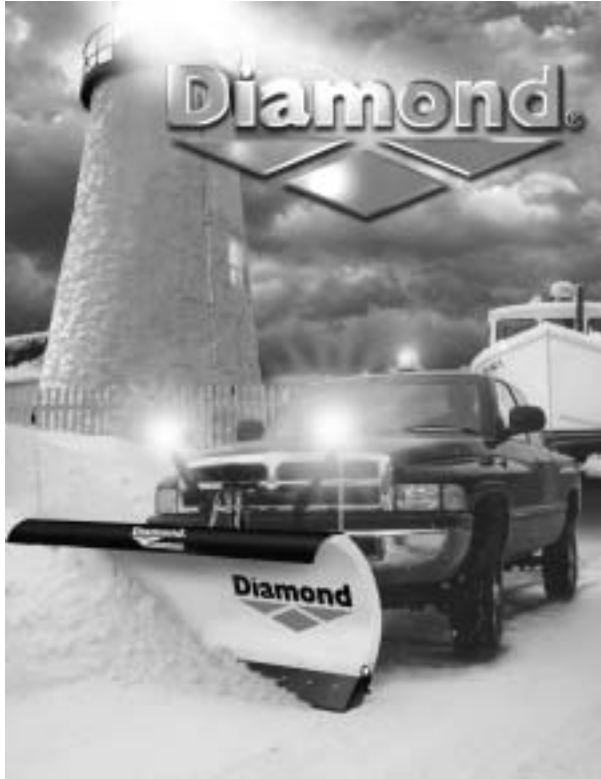

Table of Contents	Page
Introduction	2
Tripedge Series	
Get to Know Your Diamond MDII Snowplow	3-6
Get to Know Your Diamond Snowplow	7-8
Blade Specifications	9-10
Controls & Operating Instructions	11-12
Diamond MDII Snow Plow Instructions	13-16
Snowplow Operation	17
Removing & Attaching Snowplow	17
General Maintenance & Adjustments	18-19
Troubleshooting	20-22
Efficient Snow Clearance	23
Keep Snow Under Control	23
Selecting Equipment	24
Hourly Snow Clearing Capacities	24
Plow with the Storm	25
Establishing Snow Clearance Plans	26
Snowplowing Tips from the Pros	27-29
Minerals and Chemicals for Ice Control	30
Ice Control Spreaders	31-32
Fast Moving Parts List	33-34
Accessories	35-36
Specifications	37-38
Warranty Card	Back Cover

Introduction

Snow, despite the beauty it may impart to a bleak winter landscape, poses the dual threat of inconvenience and danger. The environmental conditions associated with snow, not to mention the health hazards and economic loss it may impose, seriously endanger thousands of lives annually. Business and industry suffer, and millions of snowbelt residents may be affected by a single snowstorm.

Diamond Equipment has published this manual to help you get maximum performance from your Diamond Snowplow and familiarize you with the features designed for efficiency and safety; be sure you recognize and understand them. Follow recommended operation and maintenance instructions, so when the storm hits, your Diamond Snowplow will be ready and you will know how to plow like a pro. **Do not equip any vehicle with a snowplow without consulting manufacturer's recommendations.**

Vehicles with Diamond Snowplows installed may be so equipped as to meet vehicle manufacturers' specifications and recommended options for snowplowing use. **Most vehicle manufacturers insist that vehicles which are to be used for snowplowing be equipped with certain options and**

Diamond snowplow equipment should only be used on vehicles equipped with the manufacturer's snowplow preparation packages. Snowplowing without the original snowplow preparation package may damage your vehicle and the added weight of the equipment may impair the operation and control of the vehicle. Snowplowing with a vehicle that the manufacturer does not recommend for that purpose may void your new vehicle warranty. If your vehicle is not originally equipped with the snowplow preparation package, additional equipment may be necessary before snowplowing. Owners of these vehicles should consult their truck dealer before purchase or installation of equipment. CAUTION: The installation, on any vehicle, of these parts is not a full substitute for the original equipment snowplow preparation package.

accessories, and it is so stated in vehicle manufacturer specifications for snowplow application.

WARNING: Deployment of an air bag while using a Diamond snowplow will not be covered under Diamond Equipment warranty.

We also recommend that, for optimum performance, vehicles used for snowplowing be equipped with:

- Four-Wheel Drive
- Minimum 60 Amp Alternator or larger
- Minimum 70 Amp Battery or larger (550 C.C.A.)
- Mud and Snow Tires
- Increased Radiator Cooling
- Automatic Transmission
- Transmission Cooler
- Power Brakes
- Power Steering

Under the continuing Diamond Product Improvement Plan, Diamond Equipment reserves the right to change design details and construction without prior notice and without incurring any obligation.

Get to know your Diamond MDII® Snow Plow

1. Blade

Steel or Polyethylene sheet is bump and corrosion resistant. Built to last.

2. Adjustable Tripedge Extension Springs

Tripedge gives way when objects are struck at ground level.

Note: Trip Spring tension should be checked on a regular basis during the snowplowing season. See page 18 under SNOWPLOW Paragraph 4 for more information.

3. Power Angling Cylinders (1-1/2" x 10")

Hydraulically positions the moldboard straight, or to right or left.

4. Cutting Edge (Optional)

Replaceable, high carbon steel provides extra long operating life. Recommended for commercial plowers.

5. Wear Shoes

Wear Shoes are an integral part of the Tripedge to reduce wear.

6. Pushframe

Designed to attach the snow plow to the vehicle, to pivot blade for angle plowing, and to hold plow at proper distance in front of vehicle.

7. Upper/Lower Pivot Pins

Pins that attach blade to pushframe.

8. Clevis Frame

Allow snow plow assembly to be attached or detached from vehicle in minutes.

9. MDII® Lift Frame

Allows for fast, complete removal of front end hardware, snow plow lights and hydraulic unit in one complete module.

10. Attaching Pins

Pull 4 blue pins to remove complete assembly or pull 2 yellow pins to remove moldboard assembly.

11. Lift Arm

Dual Chain locks in position to lift snow plow.

WARNING: LIFT ARM EXTENDS BEYOND BUMPER OF VEHICLE. TO MINIMIZE DAMAGE FROM A FRONT END COLLISION, LIFT ARM SHOULD BE REMOVED FROM VEHICLE WHEN SNOW PLOW IS REMOVED.

12. Diamond Snow Plow Lights

Complies with the Federal Motor Vehicle Safety Standards.

13. Electric Hydraulic Power Unit (E-60H, E-57H)

Operates snow plow hydraulically- raises, lowers, angles, holds and floats moldboard in plowing position.

14. Sno-Flo® Powder Coat

Baked on finish that looks like glass, provides an extremely hard, low friction surface that outlasts ordinary paint by a large margin.

15. Crankstand

Positions Moldboard and Lift Frame for easy attaching and detaching.

16. Hydraulic Cover

Protects the Hydraulic Unit from the elements and also enhances the appearance of your vehicle.

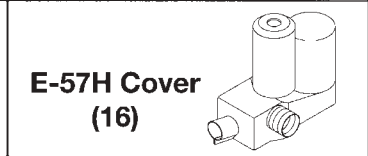
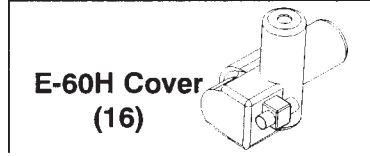
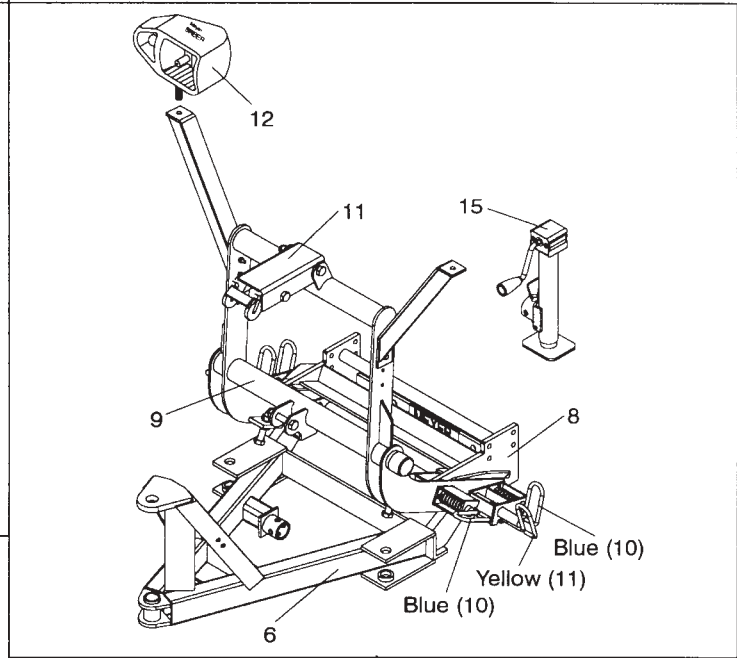
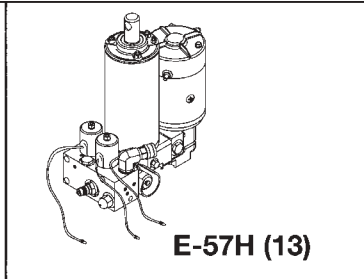
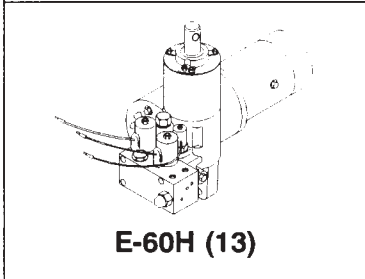
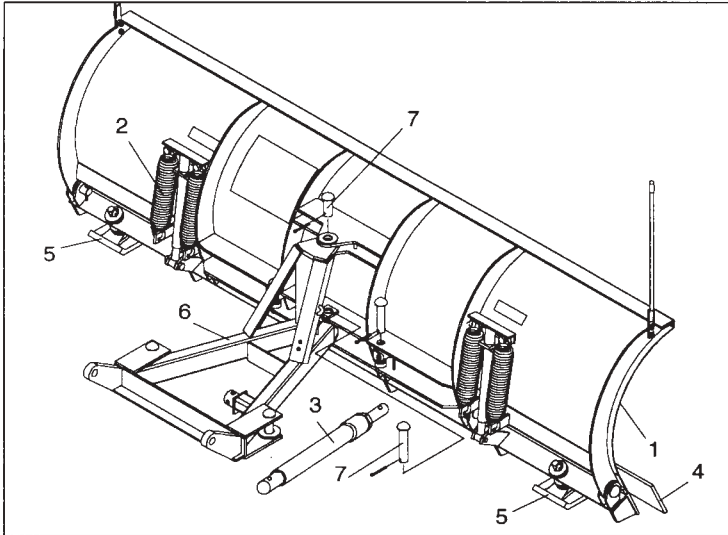

CRANKSTAND STORAGE

To store Crankstand on the Lift Frame slide the tube that is attached to the side of the Crankstand over the receiver tube on the driver's side of the Lift Frame. Insert the chain locking pin through the vertical holes on both the tubes. **Note: Crankstand should always be fully retracted (up) and be pinned in the vertical transport position when not in use.** Receiver Tube Cap may be placed over the driver side transport tube while the Crankstand is in use on the A-Frame. The Receiver Tube Cap may also be switched over to the Adjustment Tube of the A-Frame when the Crankstand is mounted to the Lift Frame.

Storage of the Crankstand is the responsibility of the operator. The stand can be stored on the lift frame in the retracted position to the driver's side transport tube or inside the vehicle cab.

HYDRAULIC COVER

Install Black Hydraulic Cover before installing the Lift Assembly to the Lift Frame. Begin by sliding the Hydraulic Cover down over the Lift Ram. Slide the side covering the motor carefully over the motor, do not force or stretch the Hydraulic Cover; it will fit comfortably over all parts of the Hydraulic Unit. Feed the three coil wires (red, green and black) through the hole located on backside of cover. Route coupler weather plugs through holes in cover where power angling hoses enter. Snap Cover together. **Caution:** Care should be taken with the installation and or removal of the Hydraulic Cover, including partial removal when repairs are performed on the Hydraulic Lift Unit. Tearing of the Hydraulic Cover for any reason will not be covered under the Diamond Warranty.

ATTACHING MOLDBOARD ASSEMBLY ONLY

Attach A-Frame to Lift Frame by connecting Crankstand to the adjustment tube in the center of the A-Frame Frame. Insert the chained locking pin all the way through the vertical holes on both the tubes. Crank up A-Frame until the holes on the back ears of the A-Frame are about 12" off the ground. Pull out the Yellow Handle Pins on both sides of the Lift Frame. Twist handle slightly to the right or left disengaging the pin. Pull truck up to the A-Frame / Moldboard assembly aligning the A-Frame ears between the two lift frame plates until contact is made with the Clevis Frame. Once you feel contact, push the moldboard assembly a few inches forward, this insures proper alignment so that the A-Frame is square to the Clevis Frame. Adjust the Crankstand up until the front of the truck raises slightly. Rotate the Yellow Handled Pins so that the small leg realigns with the slot, engaging the pin. The spring loaded pin should snap into place locking the A-Frame to the lift frame. **Note:** If pins do not properly engage move the truck slightly forward a few more inches and/or adjust (raise or lower) the Crankstand until pins lock into place. If only one pin should engage, retract the stand to the full upright position. Remove the Crankstand from the A-frame by removing the chained locking pin. Reattach the Crankstand to the transport tube on the driver's side of the Lift Frame in the vertical transport position. Attach the Lift Chain to the Lift Arm through the two hooks on the lift arm. Adjust the lift chain at the lift arm so that there are 2-3 links of slack. This ensures that the plow blade will lift fully and be able to follow the ground contour while plowing. Raise the plow with the hydraulics and swing the moldboard slightly left or right until the pin engages.

DETACHING THE COMPLETE ASSEMBLY

Leave control switch in lower float position and push down on the Lift Arm. Disconnect the electrical plug and slip on weather caps over both ends. Attach Crankstand to the adjustment tube in the center of the A Frame using the chained locking pin. **Caution: Crankstand must be secured at all times.** Adjust the Crankstand down until the bottom of stand touches the ground. Pull and twist the two rear Blue Handle Pins to disengage. Next pull and twist the two front Blue Handle Pins to disengage. If the pins do not pull easily, adjust stand up or down slightly to remove tension on the pins until they disengage. At this time the lift frame should be leaning forward slightly, at rest on the top of the Crankstand. Pull truck away.

DETACHING MOLDBOARD ASSEMBLY ONLY

Leave control switch in lower float position and push down on the Lift Arm. Disconnect hydraulic couplers and Lift Chain from Lift Arm. Attach Crankstand to the adjustment tube in the center of the A-Frame using the chained locking pin. **Caution: Crankstand must be secured at all times.** Adjust the Crankstand down until the bottom of stand touches the ground. Pull and twist the Yellow Handled Pins to disengage. If the pins do not pull easily, adjust stand up or down slightly to remove tension on the pins until they disengage. Pull truck away.

ATTACHING THE COMPLETE ASSEMBLY

Check that all four Blue Handle Pins are disengaged. Drive the truck up to the MDII assembly centering the hood of the truck to the lift arm to assure proper alignment with lift frame guide plates until contact is made. Once contact is made drive forward, pushing the assembly a few inches. This insures the A-Frame is square to the Clevis Frame for proper pin attachment. Adjust the Crankstand up

until the front of the truck raises slightly. The rear Blue Handle Pins should now be aligned with the rear holes on the clevis frame. Twist all Blue Handle Pins so that the small leg re-aligns with the slot, engaging the pins. The rear spring loaded pins should snap into place. Note: If pins do not lock immediately the A-Frame is not square to the Clevis Frame. Move truck slightly forward and/or adjust the Crankstand up or down until rear pins engage. Once the back pins are locked push the top of the Lift Frame towards the truck locking the front pins to the clevis frame. Remove the Crankstand from the A-frame by removing the chained locking pin. Reattach the Crankstand to the transport tube on the driver's side of the Lift Frame in the vertical, retracted position. **Caution: Crankstand must be secured at all times.** Reattach the one step electrical connection.

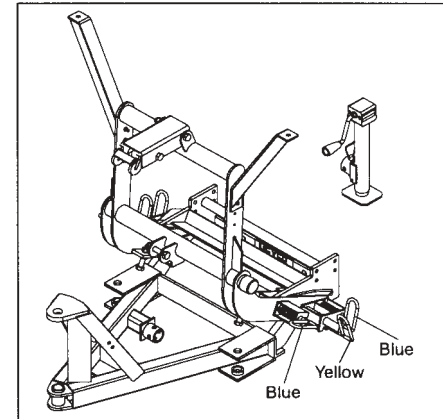

Get to know your Diamond Tripedge Snowplow

1. Blade

High strength steel. Built to last.

2. Adjustable Tripedge Extension Springs

Tripedge gives way when objects are struck at ground level.

NOTE: Trip spring tension should be checked on a regular basis during the snowplowing season. See Page 18 under SNOWPLOW Paragraph 4 for more information.

3. Power Angling Cylinders

Enables the operator to hydraulically position the moldboard straight, or to right or left, by simply activating the fingertip control switch.

4. MDII Attaching System

Rubber coated stainless steel pins give you the choice of removing the plow, mount, hydraulics, and lights (blue pins) or to remove only the plow (yellow pins).

5. Cutting Edge (optional)

Replaceable, high carbon steel provides extra long operating life. Recommended for commercial plowers.

8. Wear Shoes

Wear shoes are an integral part of the tripedge to reduce wear.

7. Electric Hydraulic Power Unit

Operates snowplow hydraulically - raises, lowers, angles, holds and floats blade in plowing position.

8. Pushframe

Designed to attach snowplow to vehicle, to pivot blade for angle plowing, and to hold plow at proper distance in front of vehicle.

9. Upper/Lower Pivot Pins

Pins that attach blade to pushframe.

10. Lift Arm

Dual chain locks in position to lift snowplow. **WARNING: Lift arm extends beyond bumper of vehicle. To minimize damage from a front-end collision, lift arm should be removed from vehicle when snowplow is removed.**

11. MDII® Mounting System

Allows for fast, complete removal of all front end hardware, snowplow lights, hydraulic unit, moldboard, sector and pushframe, in one complete module.

12. Snowplow Lights

Lights and brackets comply with the Federal Motor Vehicle Safety Standards.

13. Tubular PULL-AWAY™ Mounting System

Allows for fast removal of all snowplow components in two complete, easy to manage, modules.

14. Tubular PULL-AWAY™ Easy Hitch™ System

Allows moldboard, sector and pushframe to be detached and attached as a separate module in minutes.

MDII® Mounting System

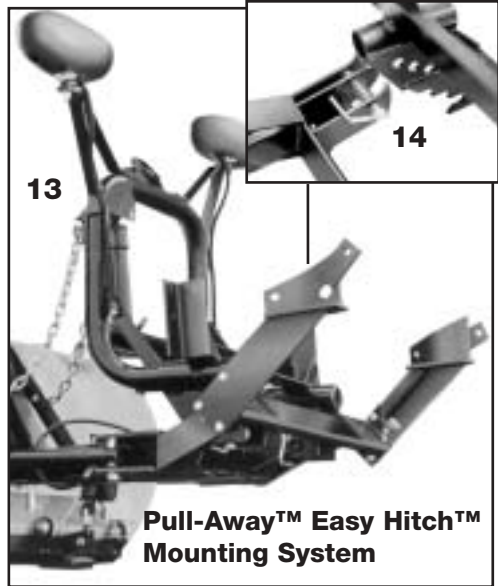
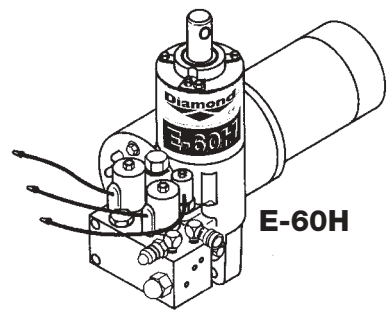
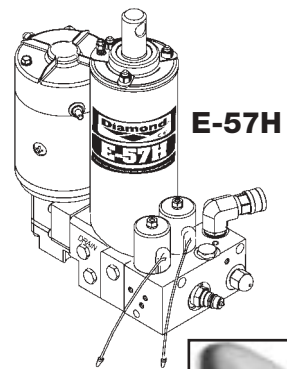
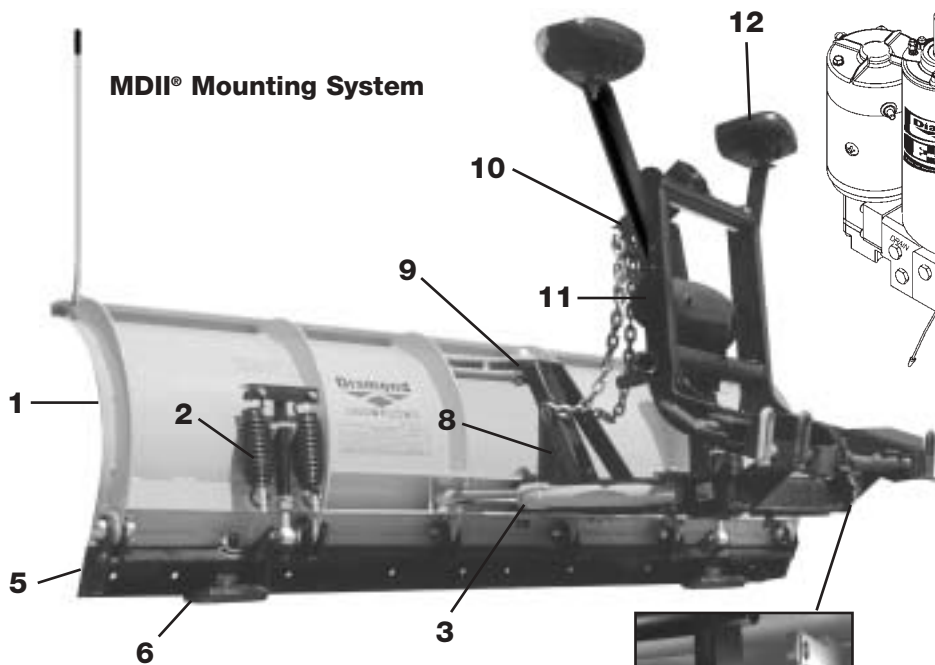

Pull-Away™ Easy Hitch™ Mounting System

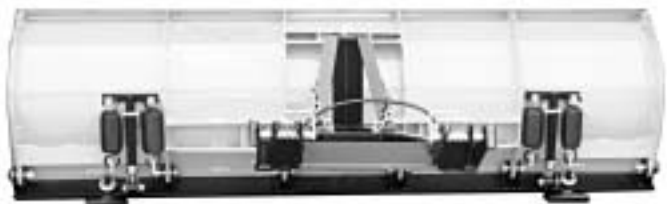

TRIPEDGE SERIES

Model 7.5

For 1/2 and 3/4 ton 4x4 Standard Duty
Pickups and Sport Utility Vehicles

STEEL MOLDBOARD SPECIFICATIONS

BLADE WIDTH	7 1/2'
BLADE HEIGHT	27 5/16"
GAUGE STEEL	12 Gauge
VERTICAL RIBS	6
TYPE OF SPRINGS	Extension (4)
NUMBER OF TRIP-EDGE PINS	6
CUTTING EDGE (OPTIONAL)	2
PLOW WIDTH AT FULL ANGLE	81"
PUSHFRAME	3" x 2" x 3/16"
PIVOT PIN DIAMETER	1 3/16"
POWER ANGLING RAMS	1 1/2" x 10"
AVERAGE SHIPPING WEIGHT	600 lbs.

POLY MAX MOLDBOARD SPECIFICATIONS

BLADE WIDTH	71/2'
BLADE HEIGHT	29"
MOLD BOARD SHEET THICKNESS	3/8" U.H.M.W. Polyethylene
VERTICAL RIBS	6
TYPE OF SPRINGS	Extension (4)
NUMBER OF TRIP-EDGE PINS	6
CUTTING EDGE(OPTIONAL)	2
PLOW WIDTH AT FULL ANGLE	81"
PUSHFRAME	3" x 2" x 3/16"
PIVOT PIN DIAMETER	1 3/16"
POWER ANGLING RAMS	1 1/2" x 10"
AVERAGE SHIPPING WEIGHT *	625 Lbs.

*weight is based on average depending on specific mounting



TRIPEDGE SERIES

Models 8.0, 8.5, 9.0

For 3/4 and One Ton 4x4 Standard
Duty Pickups and Cab-Chassis Vehicles

STEEL MOLDBOARD SPECIFICATIONS

BLADE WIDTH	8.0'	8.5'	9.0'	HML-10 10'	DAGT-10 10'
BLADE HEIGHT	29 3/8"	29 3/8"	29 3/8"	32"	32"
GAUGE STEEL	11 Gauge	11 Gauge	11 Gauge	7 Gauge	7 Gauge
VERTICAL RIBS	6	6	6	7	7
TYPE OF SPRINGS	Extension (4)	Extension (4)	Extension (4)	Extension (6)	Extension (6)
NUMBER OF TRIP-EDGE PINS	6	6	6		
CUTTING EDGE (OPTIONAL)	2	2	3		
PLOW WIDTH AT FULL ANGLE	86"	92"	97"		
PUSHFRAME	3" x 2" x 3/16"	3" x 2" x 3/16"	3" x 2" x 5/16"		
PIVOT PIN DIAMETER	1 3/16"	1 3/16"	1 3/16"		
POWER ANGLING RAMS	1 1/2" x 10"	1 1/2" x 10"	1 1/2" x 10"	2" x 12"	2" x 12"
AVERAGE SHIPPING WEIGHT*	800 Lbs.	825 Lbs.	875 Lbs.		

*weight is based on average depending on specific mounting

II. Controls and Operating Instructions

Tripedge Series

Special Features

1. Diamond's unique dual pivot pins and diagonal bracing system distribute plow loads better and reduce stress on the pushframe and cylinders.
2. Diamond's tripedge gives way when objects are struck at ground level. Diamond's rigid moldboard system keeps the blade upright and plowing until your truck loses traction. Fig. 2.
3. Diamond Snowplows have a more pronounced curve in the blade design which means a better job in throwing snow.
4. Diamond's heavy duty undercarriage support system uniformly distributes snow plowing loads to the vehicle frame.
5. Diamond's unique wear shoes are engineered to load up into the tripedge angle while plowing.
6. Dual chain hooks on the lift arm provide easier hookup and greater stability of the blade.
7. Pivot Pins are 1 3/16" diameter with one-piece construction to eliminate welded-on washers.

TRIP-EDGE

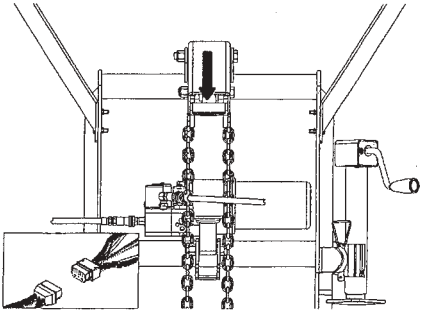
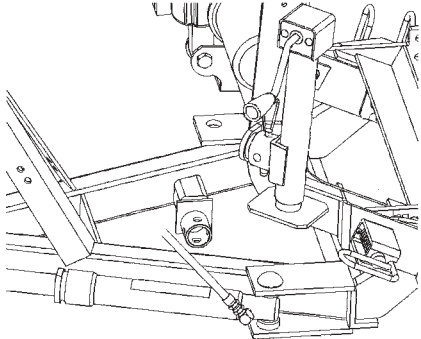
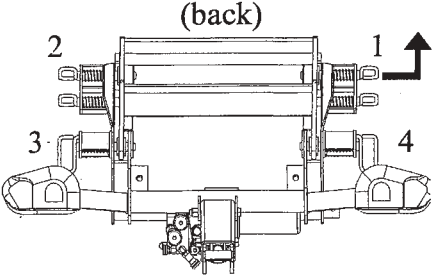

Fig. 2



Diamond® *MD II*™ Snowplow Instructions

CHOICE 1: Removing MDII (Entire Mount)

1	2	3
 <p>Lower Plow to float position and manually push lift arm down. Disconnect the one step electrical connection</p>	 <p>Remove crankstand from storage position on the side of mount and reattach to "A" frame. Crank until front of truck rises slightly</p>	 <p>(back)</p> <p>2 1 ↑</p> <p>3 4</p> <p>(front)</p> <p>Pull, then rotate rear blue pin on both sides of truck into locked out position. Repeat with front blue pins.</p>

CHOICE 1: Attaching MDII (Entire Mount)

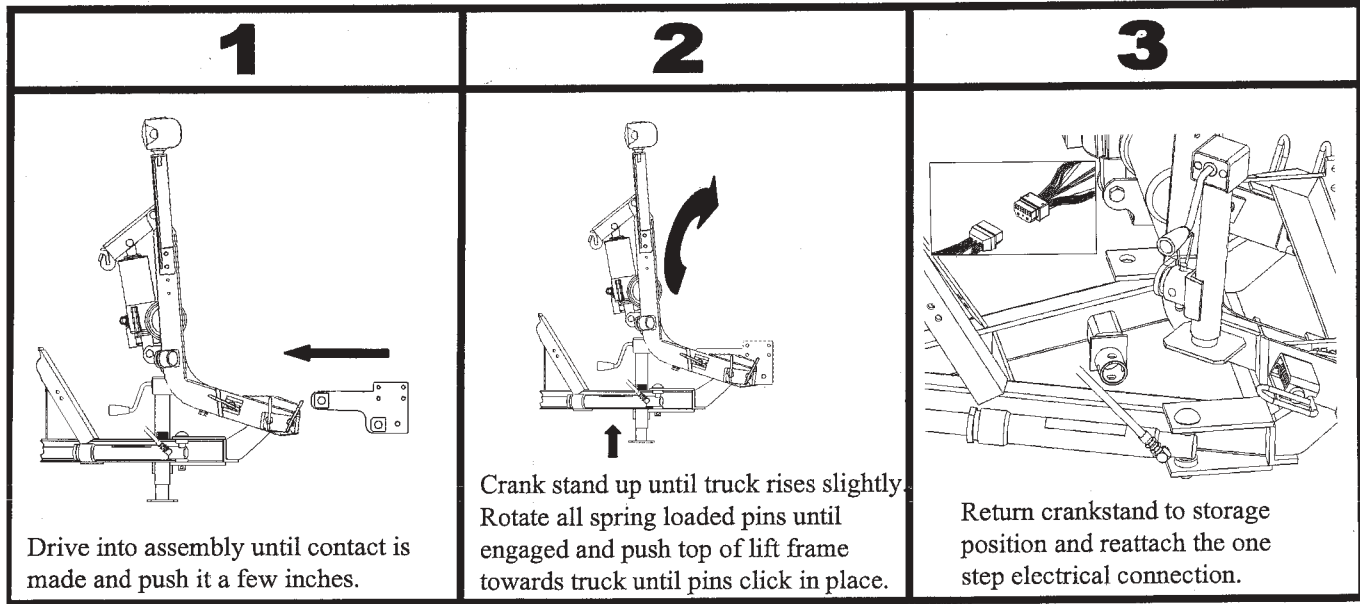

CHOICE 2: Removing MDII (Moldboard Only)

1

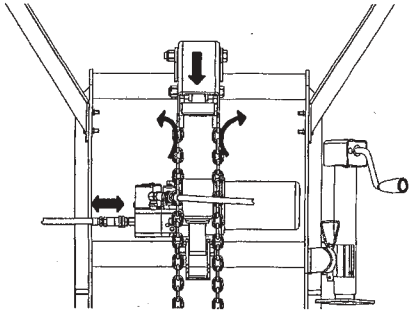

Lower plow to float position. Manually push lift arm down and remove lift chains. Disconnect quick hydraulic couplers.

2

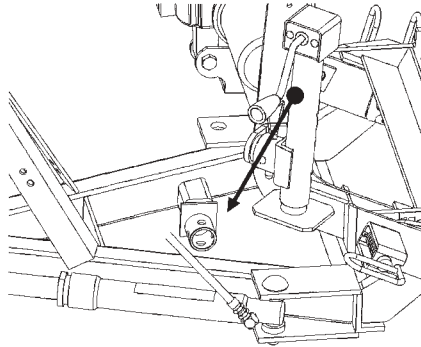

Remove crankstand from storage position on side of mount and attach to "A" frame. Crank down until truck rises slightly.

3

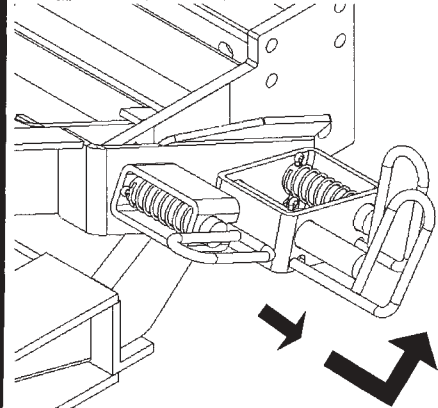

Pull and rotate yellow pin to the locked out position. (repeat on other side)

CHOICE 2: Attaching MDII (Moldboard Only)

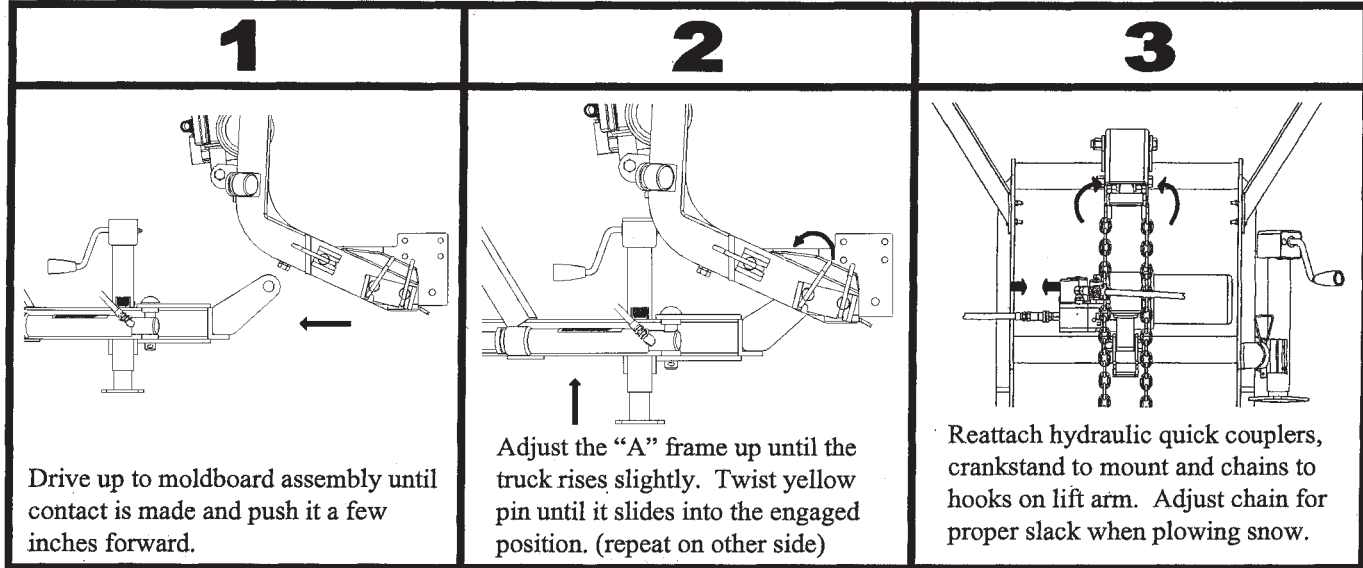

Snowplow Operation

The snowplow should only be in operation when the vehicle ignition switch and the **Electro-Touch®** control switch are in the "ON" position. Care should be taken to insure that the **Electro-Touch®** control switch is kept dry and free from moisture during normal operation.

When the **Electro-Touch®** control switch is turned "On," yellow lights illuminate the location of the individual touch pads for the functions of the snowplow: (Up), (Angle Left), (Angle Right), and (Down).



Lowering of the snowplow an inch at a time is possible by tapping the down arrow in short intervals. Holding down the down arrow will activate a green light located in the upper left corner of the **Electro-Touch®** switch. This green light indicates the snowplow is now in the Lower/Float position. In this position the snowplow will be able to follow the contour of the road and the snowplow can also be angled to the left or right. Touching the up arrow automatically cancels the Lower/Float position.

This switch is short circuit and temperature protected. All wire connections must be securely plugged together. If any of these conditions exist, the red overload LED will light. The overload LED (red light) is located in the upper left corner below the float light of the **Electro-Touch®** switch. Reset is accomplished by turning off the ignition switch or by turning the power switch off momentarily and then back on. If an overheating temperature condition exists, it will be necessary to allow the unit to cool down for approximately 2 minutes. If the overload light is still illuminated after attempts to reset the switch have failed, contact your nearest authorized Diamond Distributor for repairs.

Note: On Model E-60 only to regulate the lower speed, locate the lower adj. screw on page 19, Fig. 0-3. Turn adj. screw in to slow down or out for faster lower speed. **Adjustments must be made with moldboard on the ground.** This feature is **not** available on model E-57.

CAUTION: When the snowplow is not in operation, the **Electro-Touch®** Control Switch should be in the "OFF" position.

Over-the-Road Operation

Based on the experience of our representatives and other background, we advise a maximum transporting speed of 40 m.p.h. or locally regulated speeds, which ever is less, dependent upon road conditions. The operators should, of course, maintain a safe stopping distance and adequate passing clearance at all times.

When transporting the snowplow **to avoid engine overheating**, angle the moldboard completely, carrying it as low as permitted for safety by road and surface conditions.

Removing Moldboard Assembly

1. Be sure moldboard is on ground! The chain can have a small amount of tension to help support the back of the pushframe.
2. Pull hook-up pins in pushframe outward and turn to hold in place.
3. Lower lift ram all the way and detach chains from lift arm. Reverse the above procedure to reattach snowplow to vehicle.
4. **WARNING:** Lift arm extends beyond bumper of vehicle. To minimize damage from a front-end collision, lift arm should be removed from vehicle when snowplow is removed.

ADJUSTING CHAIN FOR PROPER SLACK WHEN PLOWING SNOW

1. Be sure moldboard is on ground and pushframe is reattached at proper hole in front mounting frame.
2. Be sure lift piston is fully retracted.
3. Hold chains taut and choose the third link above lift arm, place that link in lift arm locking groove. This procedure will provide the proper amount of slack when snowplowing for the moldboard to follow the contour of the ground. You may wish to mark these links with paint or tape for easy identification. Due to the differences in vehicle ride heights, extra chain links may vary in length.

General Maintenance

Diamond Equipment recommends this maintenance information for regular service. Sustained heavy operation may call for more frequent service. Snowplowing subjects a vehicle to exceptionally rugged use. As a result, it is important to inspect and bring the snowplow and vehicle up to maximum operating conditions. **Inspection should be made of both the vehicle and snowplow prior to the plowing season and after each use.**

Pre-Season Maintenance

Scheduled vehicle maintenance should be performed as recommended by the manufacturer.

Don't forget that in addition to keeping equipment in order:

1. Keep windshield wipers, heaters and lights working.
2. Diamond offers as standard equipment quartz halogen snowplow lights for even brighter illumination.
3. Equip vehicles with chains where necessary.
4. Provide operators with protective clothing and with rubber gloves for handling snow melting chemicals.

VEHICLE ELECTRICAL SYSTEM—For maximum efficiency, the vehicle supporting the snowplow must be properly serviced. The system should consist of at least a 70 amp/hr. battery and a 60 amp alternator. Be sure to check regularly:

1. Battery terminals to assure they're clean and free of corrosion.
2. Electrical connections, to assure they're tight and corrosion-free. Taping may be called for. All wires must be held clear of moving or hot engine parts or sharp sheet metal.
3. Battery must be in top operating condition.
4. Alternator and regulator, to assure maximum electrical output.

SNOWPLOW

NOTE: ALWAYS lower moldboard to ground when vehicle is not in use. Check the Troubleshooting Chart, pages 20-22, and Post Season Maintenance, page 19, for advice on maintaining the unit.

1. Check and maintain hydraulic fluid reservoir level to 1" - 1 1/2" from top cap. (Lift cylinder in down position.)
2. Check entire hydraulic system for leaks. A significant drop in hydraulic fluid level is evidence of a leak which must be corrected to prevent serious damage. See page 19
3. Before and after each season, remove sector pivot pins, thoroughly grease pivot tubes and reinstall pins. Lubricate all pivot points with chassis lube.
4. **ADJUSTING TRIP SPRING TENSION** - Tighten adjustment nut to the point when spring coils begin to separate. Tighten bottom locknut to hold in place.
5. **WEAR SHOES**
 - A. Inspect moldboard wear shoes for wear and height adjustment.
 - B. Always replace wear shoes as soon as they start to wear through.
 - C. Adjust the wear shoes to maintain cutting edge height of 1/2" above ground in snowplowing position. (Can be set higher when used on gravel driveways.
6. **CUTTING EDGE**

Replace the cutting edge before it wears to the attaching bolts. This will prevent permanent damage to the trip edge.
7. **MOUNTING BOLTS**

Retighten all mounting bolts after first snowplowing session and at regular intervals through the season.
8. **SNO-FLO® PAINT**

At the beginning and end of each season, remove any accumulated rust, then paint the moldboard surface with Meyer Sno-Flo® paint to inhibit rust formation. Touch-up paint is also available in aerosol cans—both Sno Flo® yellow and black.

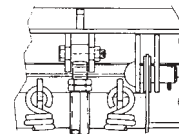

NOTE: PROTECTION AGAINST RUST AND CORROSION

When the power unit is not used for extended periods, protect the chromed lift piston fully extending and coating it with chassis lubricant. Coat the exposed portions of the power angling cylinder rods with chassis lubricant to protect against corrosion.

Post-Season Summer Maintenance

- Draining & Replacing Meyer M-1 Hydraulic Fluid**
Drain fluid through drain hole in base, shown in Figure a 0-3, by completely retracting cylinder lift position and unbolting unit to pour fluid out, or use a suction pump. Disconnect the fittings at the Power Angling cylinders, completely retract the cylinder rods and purge cylinders and hoses of all hydraulic fluid. The complete hydraulic system should then be flushed out with clean mineral spirits or hydraulic oil before adding new Meyer M-1 Hydraulic Fluid.
- Screen-Type Filters** - Clean the filters (all models) with mineral spirits or equivalent and blow out with compressed air. See Figure 0-3.
- Diamond Hydraulic Fluid M-1** is specially formulated with an anti-ice additive for almost constant viscosity in subzero temperatures. Because it is free-flowing in extreme cold, the unit's performance and efficiency are not affected by winter weather. It is effective for a maximum of one year. Always carry an extra quart of **Meyer Hydraulic Fluid M-1** or equal fluids. Use of any inferior fluids will void the Diamond warranty.
- Refill power unit with **Meyer Hydraulic Fluid M-1** by fully retracting lift piston and filling reservoir to 1 1/2" below the filler hole. Fill and bleed hoses and Power Angling cylinders by loosening hydraulic fittings at cylinders until they leak. Power angle the plow repeatedly from one side to the other until fluid flows steadily from the fittings while maintaining a constant check on the reservoir fluid level. The filling end of the cylinder should be higher than the piston end to facilitate removal of air. Raise and lower the plow several times. With lift rod fully retracted check fluid level and replace filter plug.

SNOWPLOW STORAGE

- When snowplow is disconnected, extend lift cylinder to end of stroke and coat chrome rod with light grease. This fills the cylinder with hydraulic fluid and protects the interior and exterior from rust and corrosion.
- Whenever Moldboard is disconnected, coat the exposed portions of the power angling cylinder chrome rods with light grease to protect them from corrosion.
- Be sure to reconnect quick couplers to keep them clean and prevent contamination of the system.
- Coat all pivot pins and other wear points with chassis lubricant.
- Unplug all electrical connections at power unit. Coat all connections with a dielectric compound to prevent corrosion and plug into their corresponding weather plugs. Unplug the snowplow lights, tape or use a dielectric compound at light connections to prevent corrosion.
- Remove **PULL-AWAY™** lift frame module from vehicle. Liberally coat insides of frame receiver tubes and ends of lift frame with chassis grease/anti-seize lubricant. Protect frame receiver tubes from dirt and other types of contamination by installing the receiver tube caps when the lift frame is removed from the vehicle
- WARNING: Lift arm extends beyond bumper of vehicle. To minimize damage from a front-end collision, lift arm should be removed from vehicle when snowplow is removed.**

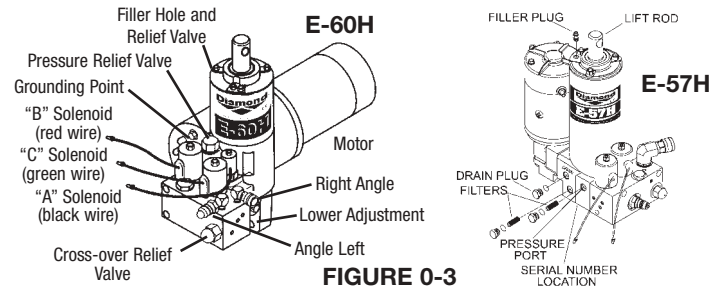

FIGURE 0-3

TROUBLESHOOTING CHART FOR ELECTRIC HYDRAULIC POWER UNITS

This chart is intended to be used as an aid in diagnosing problems on Diamond Hydraulic Power Units. It is not a substitute for factory training and experience. Be certain to read the General Information and Testing Tips sections before attempting any troubleshooting. Additional detailed information as well as all electrical schematics may be found in Service Manuals 1-667 (E-60, E-60H) and E-57H.

GENERAL INFORMATION

Before any troubleshooting is started, make certain the following conditions are met.

1. The moldboard is pointing straight ahead. This can often be done by coupling the hose from the left cylinder into the right cylinder and pushing the snowplow by hand.
2. The power angling cylinders must be installed correctly. The left cylinder has a hose with a male half of a coupler attached while the right cylinder only has the female half of a coupler attached. Reverse them if installed on wrong side.
3. The solenoid coils must be on their proper valve. The "C"- coil (green wire) must be located on the valve closest to the power angling hoses. The "B"-coil (red wire) is positioned on the valve furthest from the power angling hoses. The "A" coil (black wire) is smaller in diameter and is easily located on the E-60 power unit. On the E-57 power unit, the "A" coil (black wire) is located on the back side of the unit.
4. The electrical installation must have been made according to instructions supplied by Diamond Equipment.

TESTING TIPS

Many tests do not require removing the Power Unit from the vehicle. However, more thorough testing can be done by using the Meyer Test Stand which allows direct pressure and Amperage readings.

1. Use a screwdriver or other small tool to check for magnetism of solenoid coils "A", "B" & "C". Place the tool on the nut securing the coil and have an assistant operate the switch. You should feel strong magnetic attraction.
2. Use a test light or volt meter to determine whether there is power at harness or switches.
3. When determining Ampere draw of motor, always obtain the highest value possible, i.e., at maximum raise or angle with motor running.
4. Proper rotation for motor is indicated by an arrow on the top of the E-57 pump.
5. The pump shaft (all models) of a good pump can be turned smoothly using two fingers. If it can't be turned easily, the pump is too tight and must be replaced.
6. Pump pressure can be measured at an angle hose (note pressure at full angle) or in the pressure filter port (an adapter is necessary for the filter port). (See Figure 0-3.)
7. If hydraulic system is contaminated it is recommended that the hydraulic unit, power angling rams and hoses be drained and flushed clean. The system should then be refilled with Meyer M-1 oil. See pages 18-19.

Troubleshooting Chart for Electric Hydraulic Power Units

MODEL	CONDITION	POSSIBLE CAUSE	CORRECTION
All Power Angling Models	Plow does not lift or lifts slowly- motor operates.	<ol style="list-style-type: none"> 1. Low hydraulic fluid level 2. Discharged battery. 3. Leaking or open “A” cartridge. 4. No current to “B” coil. (red wire) 5. Inoperative “B” coil. (red wire) 6. Malfunctioning motor. 7. Malfunctioning pump. 	<ol style="list-style-type: none"> 1. Add fluid to proper level. 2. Recharge battery. 3. Clean or replace “A” cartridge. 4. Locate malfunction and repair. 5. Replace “B” coil. (red wire) 6. Repair or replace motor. 7. Replace pump.
All Power Angling Models	Plow does not angle right - motor operates.	<ol style="list-style-type: none"> 1. Improper coupler engagement. 2. Mechanical bind or interference. 3. Malfunctioning coupler. 4. No current to “C” coil. (green wire) 5. Inoperative “C” coil. (green wire) 6. Inoperative “C” cartridge. 7. Leaking or open crossover relief valve. 	<ol style="list-style-type: none"> 1. Engage coupler properly. 2. Eliminate mechanical bind or interference. 3. Repair or replace coupler. 4. Locate malfunction and repair. 5. Replace “C” coil. (green wire) 6. Clean or replace “C” cartridge. 7. Clean or replace crossover relief valve.
All Power Angling Models	Plow does not angle left - motor operates.	<ol style="list-style-type: none"> 1. Improper coupler engagement. 2. Mechanical bind or interference. 3. Malfunctioning coupler. 4. Leaking or open crossover relief valve. 	<ol style="list-style-type: none"> 1. Engage coupler properly. 2. Eliminate mechanical bind or interference. 3. Repair or replace coupler. 4. Clean or replace crossover relief valve.
All Power Angling Models	Plow will not angle - Motor operates.	<ol style="list-style-type: none"> 1. Improper coupler engagement. 2. Mechanical bind or interference. 3. Leaking or open crossover relief valve. 	<ol style="list-style-type: none"> 1. Engage coupler properly. 2. Eliminate mechanical bind or interference. 3. Clean or replace crossover relief valve.

MODEL	CONDITION	POSSIBLE CAUSE	CORRECTION
All Power Angling Models	Plow will not hold in angled position.	<ol style="list-style-type: none"> 1. Air in cylinders and hoses. 2. Leaking "C" cartridge O-rings. 3. Leaking or open pilot check valve. 4. Leaking crossover relief valve. 5. Crossover relief valve opening at too low a pressure. 	<ol style="list-style-type: none"> 1. Bleed cylinders and hoses. Tighten P.A. cylinder gland nut. 2. Replace O-rings. 3. Clean or replace pilot check valve. 4. Clean or replace crossover relief valve. 5. Replace crossover relief valve.
All Power Angling Models	Motor does not operate.	<ol style="list-style-type: none"> 1. Discharged or defective battery. 2. Loose or corroded electrical connections. 3. Inoperative starter solenoid. 4. Malfunctioning control switch. 5. Malfunctioning motor. 	<ol style="list-style-type: none"> 1. Recharge or replace battery. 2. Clean and tighten electrical connections. 3. Replace starter solenoid. 4. Replace control switch. 5. Repair or replace motor.
All Power Angling Models	Plow does not lower.	<ol style="list-style-type: none"> 1. No current to "A" coil. (black wire) 2. "A" cartridge jammed in closed position. 3. Inoperative "A" coil. (black wire) 	<ol style="list-style-type: none"> 1. Locate malfunction and repair. 2. Clean or replace "A" cartridge. 3. Replace "A" coil. (black wire)
All Power Angling Models	Plow creeps down.	<ol style="list-style-type: none"> 1. Leaking "A" cartridge. 2. Leaking "A" cartridge O-ring. 3. Leaking "B" check valve. 4. Leaking ram packing cup. 5. Leaking O-ring at bottom of lift cylinder. 	<ol style="list-style-type: none"> 1 Clean or replace "A" cartridge. 2. Replace O-ring. 3. Clean or replace "B" check valve. 4. Replace ram packing cup. 5. Replace O-ring.

Efficient Snow Clearance Starts with Planning

PREPARING AREAS, USE OF GUIDE MARKERS

Every area to be plowed should be inspected before snowfall for potential hazards. Holes should be repaired, raised manhole covers leveled or noted and obstructions noted to prevent damage to the plow mounting or vehicle undercarriage.

Markers or stakes with reflectors should be in position to indicate boundaries of areas to be plowed, location of shut-off valves, catch basins and other hazards. Markers should be at least three feet above the ground; higher in areas of deeper snowfall.

The first step in organizing an efficient plan is to prepare a map or procure a blueprint of the area. Locate and mark all utilities, outlets, shutoffs, catch basins and possible emergency equipment that must be reached from outside.

Figure the square footage of each area and the total area. Especially note areas from which snow will have to be carried, call "trapped" areas. Although hauling is expensive, it is necessary where piled snow would limit access. Indicate clearing priorities on your map.

This may aid you in preparing a priority plan for your clearance operation.

KEEP SNOW UNDER CONTROL

Deep or heavy, wet snow, because of its increased weight, calls for more skillful and powerful plowing than light powder snow.

Always plow in low gear and **keep plowing**. Heavy snow may also require clearing a path or area for working room to move snow to another area. Remember that wet snow weighs about 12 pounds per cubic foot. As it piles up in front of a snowplow blade, the weight can quickly increase to several tons.

Where packed snow or ice must be plowed, it is sometimes necessary to lower the cutting blade to rest directly on the road surface. In that situation, plow in lowest gear for greatest power to the cutting edge. This method also prevents the plow from "climbing over" the icy surface.

If plowing very deep snow, 12 inches or more, you may have to plow with the blade partially raised to shear off successive layers of snow until a working area is clear. Then work small "bites" into the edge. The "bite" depth should be inversely proportional to the snow depth. A rule of thumb: 6 inch snow may be plowed with the entire blade width; 9-inch snow with 3/4 of the blade width; and 12-inch snow with only 1/2 of the width. Experience will show what work can be done without stalling or getting stuck.

SELECTING EQUIPMENT

Where you plan to plow, and the conditions under which you will be plowing, determine to a great extent the type of vehicle you'll find most useful. In general, three types of vehicles are available as the power source of snow clearance. Each type has certain inherent advantages depending upon the particular situation.

Four-wheel drive UTILITY VEHICLES and TRUCKS have proven most effective in general snowplowing situations. They have excellent traction and maneuverability and are extremely easy to handle.

Two-wheel drive TRUCKS, particularly those of 1 1/2 to 3 tons, are best for straight line road clearance and in large open areas.

TRACTORS are effective for trapped areas in which visibility is limited, plus a rear grader blade can be used in conjunction with the Diamond Snowplow.

Diamond Snowplow's custom design for specific vehicles provides the advantage of easy, fast attaching and detaching. This feature permits utilization of vehicle versatility as weather conditions and job requirements demand.

20 m.p.h. is a maximum snowplowing speed under ideal conditions, assuming the driver is familiar with the roadway or area to be cleared. Under unfamiliar or hazardous conditions, or if there is poor visibility, we recommend reduced speed and extreme caution.

Careful analysis of the area you intend to clear of snow will direct you to the types of equipment you'll require. Check Table 1, Average Hourly Snow Clearing Capacities, for recommended equipment depending upon the area in which you'll be working.

Then, match the vehicles you already have with the snow removal equipment you need. If your vehicles do not have the capacity to clear all major access areas within two hours, you should increase clearing capacity with additional equipment or arrange for assistance through a contract plowing service.

AVERAGE HOURLY SNOW CLEARING CAPACITIES*
TABLE 1

	Snow Plow Size	Open Area (sq. ft.)	Trapped Area (sq. ft.)	Straight Line (no. of miles of roadway cleared in 2 passes)
Tractors	7 foot	33,000	25,000	2 1/2 miles
4 Wheel Drive Utility Vehicles	6 1/2 foot	53,000	21,500	5
Trucks 1/2-1 Ton (2 WD)	7 - 7 1/2 foot	38,000	19,000	4
(4 WD)	7-8 foot	88,000	42,500	6
1 1/2 - 2 Ton	8 1/2 - 9 foot	67,500	30,000	7 1/2 **
2 1/2 - 3 Ton	10 foot	67,500	~	10 **

• Based upon regional interviews with knowledgeable contractors (6" snowfall cleared by operators with average ability).

** Based upon recommended maximum plowing speed of 20 mph.

~ Not recommended for use, except in very large areas of this type. Use 1 1/2 ton figures if necessary.

Plow with the Storm

It is of utmost importance to remember one basic rule -Always plow with the storm. Start plowing when snow is 1 to 4 inches deep, depending upon traffic or other limitations. Heavy wet snow can be very hazardous when just 1 inch is on the ground. Accumulations of more than 4 inches can be very difficult to clear.



Angle Moldboard for Optimum Results. You will not be able to plow snow of any significant depth straight ahead for more than a short distance. Set the moldboard at the best angle for rolling snow sideways in the desired direction. The snowplow path, in the angled position, should exceed the tire track by at least six inches on either side. Be sure to have enough slack in the lift chain while plowing so the cutting edge of the moldboard can follow the ground contour. Use the adjustable runner shoes to set the bottom edge of the plow just above the ground for best operation.

It's important to recognize the significance of even a few inches of snow. Besides being slippery, especially when wet, snow can be extraordinarily heavy, and make auto travel impossible. Snowfall of just 1 to 3 inches will produce hazardous traffic and roadway conditions even for experienced drivers.

Snow is heaviest when wet, and most difficult to handle. The National Weather Service reports that a 6-inch, average weight snowfall on a 200 x 200 foot parking lot weighs 62 tons. Heavy, wet snow for the same area might weigh as much as 248 tons. If the heavy snow had to be hauled away, you'd need 74 full loads on a 10-yard truck.

Obviously, the only way to assure clear traffic areas is to be prepared with the proper equipment and expertise to open arteries and areas to traffic. Remember to keep current with accurate snowfall information from local weather bureaus via radio and television.

Two Established Snow Clearance Plans

These two snowplowing techniques have been time-and operation-tested. Use them as guidelines for most snowplowing strategies. Plan I is for smaller areas of 50,000 sq.ft. or less. Plan II is for larger establishments having more than 50,000 sq.ft. to be cleared.

PLAN I (less than 50,000 sq. ft.)

Recommended equipment: A vehicle (either four-wheel drive utility or truck) with snowplow, snow shovels, chemicals.

Recommended procedure: **PLOW WITH THE STORM.**

Begin plowing at the suggested accumulation for your type of establishment (i.e., 1" for commercial and institutional areas; 2" for industrial establishments; 3" for municipal and residential areas.) Continue until snow has been cleared. Don't forget - snowfall often surpasses weather forecasts. A well planned clearing schedule will help prevent the necessity for expensive emergency action.

A typical small-area strategy:

1. Keep in touch with local weather forecasts for preparatory measures.
2. Notify scheduled personnel.

3. Have vehicles and equipment inspected, fueled and ready.
4. Clear area by pushing snow first to sides of drives, around perimeters of parking areas and away from loading docks and platforms. It is often true that the smaller the establishment, the greater the proportion of "trapped" areas which will require snow to be hauled away. Always deposit snow as far back as possible for greatest use of dumping areas.
5. Use snow shovels to clear walks, gates and doorways.
6. Treat with snow-melting chemicals as needed.

PLAN II (over 50,000 sq.ft.)

Recommended equipment: The suggested number of vehicles, according to the Table "Average Hourly Snow Clearing Capacities," on page 24, with snowplows; front-end loaders if needed; snow shovels and chemicals.

Recommended procedure: As always, **PLOW WITH THE STORM.** Begin plowing at the suggested accumulation for the area and continue as required. Actual snowfall frequently exceeds forecasted conditions. Well-planned snow clearance strategy reduces the chances for expensive emergency action.

Snowplowing Tips from the Pros

SNOWPLOWING OPEN AREAS

Open areas such as parking lots require a more serious approach to planning, where to begin, and where snow can be stacked at the edges. The following will help in making a plan, thus turning out a neat, professional job.

Always turn on warning flashers when plowing. Then make a single pass down the center on the longest dimension. Angle-plow the snow toward the long sides with continuous passes until the area is cleared and snow is all stacked around the outside edges.

For larger areas, efficient plowing calls for clearing area immediately in front of buildings and working away from buildings toward the outer limits of the area. When snow is quite deep, it might be necessary to push the excess into piles out of main traffic lanes for later handling. Areas 100,000 sq.ft. or more -- once the main artery is clear, it is usually most efficient to plow at right angles to the artery, piling up windrows by back and forth passes in alternate lanes. The windrows can later be pushed out of the way or left as is depending upon conditions.

To clean up remaining snow, you can put the blade in the straight position. Buck piles from either side to stack snow. The blade will automatically "ride" up the pile to make stacking easier.

On a dirt or slag surface, drop moldboard to ground in straight position, then raise one inch or adjust runners for desired clearance. Plow with moldboard in suspended position.

PARKING LOTS

1. Always turn on warning flashers when plowing.
2. Make first pass to clear area into which you will later push more snow.
3. Clear front in straight position and clean up remaining snow. Buck piles from either side to stack snow. Blade will automatically "ride" up pile to aid in stacking.

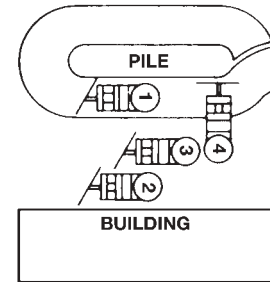

STRAIGHT LINE SNOWPLOWING

This method is most efficient for drives, streets, roads and walkways. Moldboard type blade snowplows mounted on utility vehicles or service trucks are best for such an operation.

Set the snowplow moldboard at an angle so that the snow is rolled to the shoulder or curb.

Single lane walks, roads and aisles can often be cleared with one pass.

When the road is more than twice the moldboard's width, plow a center lane for the first full pass. Then, in follow-up passes, work the snow to the sides. The diagram illustrates plowing sequence for a typical 20-foot road.

Corner clearing is almost automatic when clearing intersecting streets. When snow is heavy, a little "stop over" snow may have to be removed from intersections by additional short passes.

We recommend a speed of 5 to 15 MPH for this kind of plowing. Of course, road surface, weather conditions and equipment will influence your speed.

Plow with the storm.

WIDE DRIVEWAY

1. Make one pass down center with blade in straight position.
2. Push snow to side with moldboard angled.
3. Do the same on either side.

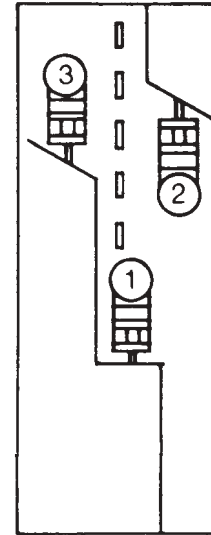

DRIVEWAYS

1. Plow toward garage pushing snow to one side.
2. Set blade to straight position, lift it as high as possible and drive through snow to garage. Drop blade and back drag to street.
3. Back into driveway and angle blade again. Use as many passes as necessary to clear drive.

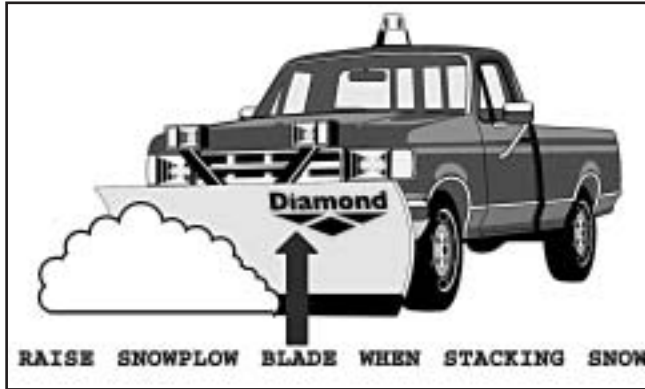
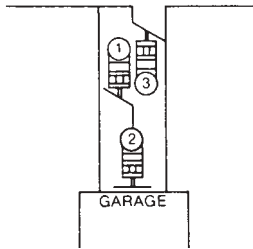

CLEARING TRAPPED AREAS

Areas where there is little or no space for stacking cleared snow are considered "trapped." An example is an area requiring full access from surrounding buildings. Snowplowing techniques are the same as for any other space of comparable size, but heavy accumulations must be piled for removal by truck.

CLEARING RESIDENTIAL AREAS

Driveways and aprons are most efficiently cleared by maneuverable four-wheel drive vehicles. Recommended procedure is to enter the driveway rolling snow away from the residence. Stop about two-thirds of the way in; set the blade in bucking position, lift as high as possible, then drive through the snow to the garage. Drop the blade and back drag to the street. Turn around, back into the cleared path to the garage, reset the blade angle and continue rolling snow away from the house. Complete as many passes as necessary to clear the snow.

STACKING

When snow clearance conditions are perfect, snow can be merely pushed out of the way to unused areas. The first storm of the season, plow back from the drive area to allow space to pile future snowfall. It is usually necessary to pile snow up to considerable heights. In that case, **push the snow forward and upward by raising the snowplow as you move into the pile.** The vehicle's momentum will carry the plow into the pile, avoiding equipment damage. The pile should slope outward, so later snows can be pushed upward. **WARNING:** Stacking snow or pushing up into high snow piles with the plow in Lower/Float or Angled position can cause damage to the Snow Plow components or the vehicle that will not be covered under the Diamond Equipment Warranty Program. Such damage may include, without limitation, twisting the A-Frame, the Moldboard hitting the Lift Arm, or the Plow Markers striking the vehicle.

Minerals and Chemicals for Ice Control

Except in very light snow, minerals or chemicals should never be used in place of snow plowing. However, in combination with trained personnel and equipment, minerals or chemicals play an important part in controlling ice and snow. Whenever possible, apply minerals or chemicals before a snowfall. You'll use less, and it will be less damaging for the environment. You may have to increase the use of minerals or chemicals at night and as temperatures fall.

Experts agree that the use of chemical mixture of two parts mixed chemicals (1:3 calcium chloride to salt, by weight) mixed with one part abrasive (cinder, sand or slag) is more effective than rock salt alone in melting snow and ice below 30°F. One hundred fifty pounds of such mixture with abrasives will treat a 50,000 sq.ft. surface.

It is imperative to treat priority areas such as hills, heavy traffic areas, bridges and intersections first, especially where snow may compact and adhere to the road surface, causing icy road conditions. When slush begins to stiffen and refreeze, it will be necessary to plow again and reapply chemicals.





MEYER MATE

The Meyer Mate is constructed of thermoplastic without the added weight of a steel frame. The motor is enclosed in the thermoplastic to protect it from the elements while the built in vibrator allows the free flow of materials. The 9 cu. ft. spreader is capable of spreading salt, sand, salt/sand mixture or calcium chloride from 3' to 30'. Attaching the Mate requires no tools or drilling. It uses the existing ball hitch hole and a nylon ratchet strap to clamp the spreader to the tailgate face.



REPLACEABLE TAILGATE SPREADER

- Spreader replaces dump body tailgate
- Positive feed from entire width
- Spreads free flowing chemicals-salt and/or sand
- Spread width of 4' to 40'
- Capable of accepting electronic controls
- Mounts easily on most one-ton dump bodies

Feed Mechanism:

- Auger and agitator driven by hydraulic motor through chain and sprockets
- Hydraulic safety interlock system

Spinner Assembly

- 18" polyurethane disc



INSERT HOPPER SPREADER

The Diamond 1.8 & 2.0 cubic yard capacity V-box spreader for pickup trucks mounts and stores as a single unit. This mechanically-operated spreader is powered by an electric start 8 H.P. gas engine, which drives a high torque orbital-type motor and a 20:1 ratio gearbox. Spinner and drag chain speeds work in unison with engine R.P.M. The spinner will evenly spread material from four (4) to thirty (30) feet. In-cab controls make operation easy. Stainless steel hopper also available.



MINI AND MINI JR,

The Meyer Mini (9cu.ft.) and Mini Jr (5.75cu.ft.) are ideal solutions for small and medium sized jobs: walkways, intersections, access ramps and parking lots. The no rust thermoplastic hopper and internal vertical spiral auger provide continuous and even flow of material. Adjustable controls allow spreading of #1 rock salt from 3 to 30 feet. Both units are easy to attach and detach. The Mini Jr. mounts to a standard 2" trailer receiver hitch.



LOW PRO SPREADERS - 5' (1/2 YARD), 6' (3/4 YARD), 7' (1 YARD)

The Low Pro 5', 6' and 7' spreaders are designed to have many of the popular features of the larger Insert Hopper Series in a smaller low profile design. The 9" wide conveyor chain is powered by a 10.5 Briggs and Stratton engine and electric clutch that provides 90ft. lbs. of torque capability. Hopper sides are sloped at 45 degrees to assure the free flow of Salt and/or sand. In cab controls make operation easy and the 13" spinner can be adjusted to spread 4 to 30 feet in width.

Trip Edge Accessories



"REVERSIBLE" CUTTING EDGE

Diamond's optional Cutting Edge improves performance and durability by protecting your blade's tripedge. It also gives your plow an extra edge when cutting hard pack and ice. Only Diamond's cutting edge is attached by bolts in the center of the edge, so when it wears down sufficiently you simply remove the bolts, turn it over and use the opposite edge.

DIAMOND GENUINE FAST MOVING PARTS

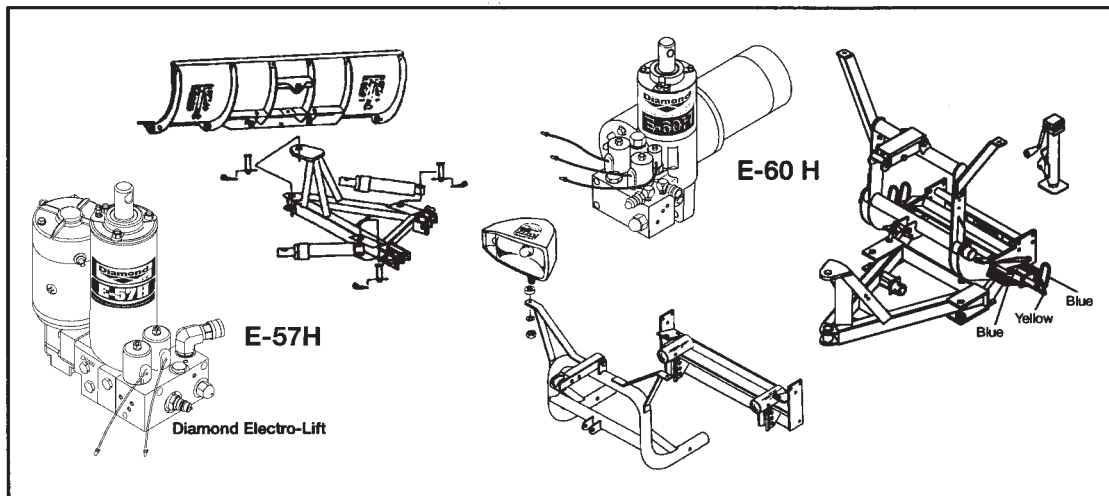

NUTS & BOLTS (STEEL)

08486	SET OF 6 TM-SERIES
08318	SET OF 12 HM-SERIES

SNOWPLOW HARDWARE

07107	CLIP SPRING
09124	EYE BOLT & NUTS
12978	TRIP SPRING TM
07017	TRIP SPRING HM
09916	MARKER KIT
13591	KING BOLT W/GREASE FIT.
09125	KING BOLT 3/4H
13598	PIVOT BOLT W/GREASE FIT. TM
08541	PIVOT PIN W/COTTER (2)
08554	PIVOT PIN W/GREASE FIT. (2)
13004	SECTOR PIN 3/4
08562	HINGE PIN W/COTTER (2) TM
10958	HINGE PIN (ONLY) HM-SERIES
08543	HAIRPIN COTTER (2)
08498	QUICK DISCONNECT W/COTTER
08667	LINCH PIN (2)
08669	HINGE PIN (11006) W/PIN (21
08670	HINGE PIN (11001) W/PIN (2)

TRIPEDGE PARTS

811000 003 001	TRIPEDGE PIN
811000 003 002	TRIPEDGE PIN
811000 003 003	UPPER PIVOT PIN
811000 003 008	LOWER PIVOT PIN
811000 005	TRIP SPRING (OLD)
811000 011	WEAR SHOE
811000 095	PLOW MARKER
811000 161	PLOW MARKER TIP
811000162	TRIPEDGE SPRING (LT)
811000163	TRIPEDGE SPRING (RT)

811000 224	5/16" KLIK PIN
814000 005	BEAM PIN SPRING
814000 015	BEAM PIN
819000 001 001	ANGLE CYL. PIN
819000 001 005	ANGLE CYL. PIN
819000 002	BEAM BOLT
819000 013	RELEASE HOOK
8501002 013	BEAM SLOTTED NUT
817000 020	CYLINDER ASSEMBLY
817000 023	CYL. PACKING SET
817000 026	DUST PLUG

FULL TRIP PARTS

CUTTING EDGES - (STEEL)

09104	TM-6.0
09100	TM-6.5 / TMP-6.5
07259	HM-9.0
07235	HM -10.0

RUBBER EDGES W/HARDWARE

08186	TM-6.5 / TMP-6.5
08187	ST-6.5
08192	HM-9.0
08193	HM-10.0

RUNNERS & SPINDLES

08514	RUNNER KIT COMPLETE TM
09127	TM RUNNER ASSEMBLY
09592	HM-9.0 / HM-10.0 ASSEMBLY
07086	RUNNER ONLY HM - SERIES
12057	SPINDLE ASSY HM-9 / HM-10
22083	LINCHPIN
20363	WASHER HM-9 / HM-10.0
20420	COTTER PIN 1/4" X 2"

TWO METER A-FRAME

13594	TM A-FRAME
10888	TM A-FRAME JEEP XJ

A-FRAMES FOR HM-10.0

13604	H.M.B.F. 31" X 28"
13606	H.M.B.A. 31" X 23"

MDII A FRAMES

13711	MDII (11") 34" X 22 1/4"
13715	MDII (15") 31" X 22 1/4"

PIVOT BARS / SECTORS

12984	TM PIVOT BAR
10891	TM PIVOT BAR JEEP XJ
12793	SECTOR HM - 10.0

POWER ANGLING CYLINDERS

05810	1 1/2" X 10" TM SERIES
05752	2" X 12" HM SERIES

ANGLING CYLINDER SEAL KITS

07705	1 1/2" CYLINDER (OMCO)
07831	1 1/2" CYLINDER (MONARCH)
07799	2" CYLINDER

HOSE AND HOSE FITTINGS

22291	MALE COUPLER 1/4 HOSE END
22292	FEMALE COUPLER 1/4 HOSE END
21855	SWIVEL ELL
21856	45 DEGREE HOSE W/SWIVEL
22857	FITTING (TALL)
22144	HOSE ASSY. 194 X 45"
15741	COUPLER

COUPLER LOW SPILL**HOSE END KIT - 15846**

22291	MALE COUPLER 1/4 HOSE END
22292	FEMALE COUPLER 1/4 HOSE END

DRIVER SIDE (LEFT) KIT - 15847

22291	MALE COUPLER 1/4 HOSE END
22294	FEMALE END 3/4-16 VALVE BLOCK SIDE

PASSENGER SIDE (RIGHT) KIT - 15848

22292	FEMALE COUPLER 1/4 HOSE END
22293	MALE COUPLER 3/4-16 VALVE BLOCK SIDE

DRIVER/PASSENGER COUPLER SETS - 15876

15847	DRIVER SIDE (LEFT) KIT
15848	PASSENGER SIDE (RIGHT) KIT

SNOW DEFLECTOR KITS (POLYETHYLENE)**FOR STEEL MOLDBOARDS**

12036	6.0 FT. LG
12037	6.5 FT. LG
12038	7.0 FT. LG
12042	9.0 FT. LG
12043	10.0 FT. LG

FOR POLY MAX MOLDBOARDS

12045	6.5 FT. LG
12046	7.0 FT. LG

ELECTRO-LIFT UNITS

15864	E-57H UNIT ONLY
15867	E-57 H UNIT ONLY MDII
15715	E-60 UNIT ONLY
15720	E-60H UNIT OLY
15756	E-60H UNIT ONLY - MDII

CONVERSION KITS**E-46 TO E-47**

15532S	TM-6.5
15535S	HM-9.0 / HM-10.0

ELECTRO-LIFT UNITS (SEAL KITS)

15254	E-57 SEAL KIT
15456	E-57
15705	E-60/E-60H MASTER SEAL KIT
15707	E-60, E60H SEAL KIT

MISC. LIFT PARTS

08594	QUICK DISCONNECT
15727	MOTOR E-60 (E-57)
15728	BRUSH KIT - FENNER
15889	PUMP ASSEMBLY - E-57
15729	PUMP ASSEMBLY - E-60
15573	BASE & STRNR. ASSY - E-57
15726	SUMP BASE ASSY. E-60
15730	COVER MTR. MOUNT E60 - E-57
15194	TOP CAP ASSY - 60H

MISC. LIFT PARTS (CONTD.)

15738	TOP CAP ASSY. - E-60
15356	A SOLENOID ASSY. - 3/8" STEM
15392	A COIL - 3/8" STEM
15393	A VALVE - 3/8" STEM
15661	A SOLENOID ASSY. 9*16" STEM
15659	A COIL - 9/16" STEM
15660	A VALVE - 9/16" STEM
15357	B SOLENOID ASSY. E-57
15380	B VLAVE E-57
15697	B SOLENOID ASSY. - E-60
15698	B VALVEE-60
15382	B COIL - E-47/E-60 (RED WIRE)
15358	C SOLENOID ASSY. - E-57 E-60
15430	C COIL - E57/E-60 (GREEN WIRE)
15381	C VALVE - E-57/E-60
15370	MOTOR SOLENOID

SWITCHES

83001	MEMBRANE SWITCH W/HARN.
80115	MEMBRANDE SWITCH
15753	HARNISS
08574	SINGLE LEVER - COMP. KIT
22092	SWITCH ONLY
15680	HARNISS
08583	FLOOR MOUNT BRACKET
15346	HDWE. BAG W/SWITCHES E-57
21919	LIFT SWITCH 0 E-57
21918	ANGLE SWITCH - E-57
15375	YELLOW HANDLE EXTENSION
15376	BLACK HANDLE EXTENSION

RECEIVER TUBE CAP KITS

08673	3" O.D. PIPE
08649	2-7/8" O.D. PIPE
08648	2-1/4" O.D. PIPE

HYDRAULIC FLUID

15134	M-1 FLUID QUART
15487	M-1 FLUID 12QT. CASE

LIGHTS- 07223

07224	PLOW LIGHT-PASSENGER
07225	PLOW LIGHT-DRIVER
07116	CONTROL MODULE
07118	"C" HARNESS
07119	ROCKER SWITCH

PAINT TOUCH UP

07026	BLACK AEROSOL (1)
08676	BLACK AEROSOL (2)
07027	SNO-FLO AEROSOL (1) YE
08677	SNO-FLO AEROSOL (12) YE
07028	SNO-FLO BRUSH-ON .6 OZ. (1) YE
08678	SNO-FLO BRUSH-ON .6 OZ. (12) YE
07066	SNO-FLO - QT. (12) YE

SINGLE HARNESS PLUG ASSEMBLY

07240	LUG ASSEMBLY
22261	MALE PLUG (VEHICLE SIDE)
22262	FEMALE SOCKET (HYD. SIDE)
22263	WEATHER COVER

HYDRAULIC UNIT COVERS

80423	E60H (DUAL TERMINAL MOTOR)
80431	E-57
80394	E60H (1 TERM.)



ELECTRO-TOUCH®

The ultimate for snowplow control. You can convert to this great new Electro-Touch® control system. This control pad can easily be placed in a variety of locations and the directional buttons are illuminated for night operations.



SNO-FLO® POWDER COAT TOUCH-UP PAINT

Super-smooth high gloss paint especially formulated for use on powder coat finishes. Available in 12 oz. aerosol cans or yellow only in small 0.6 oz. brush-in-cup bottles.

ACCESSORIES



M1 HYDRAULIC FLUID

Keep your Diamond Quik-Lift® snowplow control system operating at peak performance; change hydraulic fluid yearly. Meyer M1 Hydraulic Fluid has additives that insure peak efficient operation of all Meyer and Diamond electric hydraulic power units.



SLIK-STIK

The Slik-Stik single lever control offers you a choice of 4 mounting locations: on the floor shift selector, on the steering column shift selector, on the dash right or left, on the floor pedestal or console.



EZ-GARD®

The EZ-Gard® is designed to slide into the Diamond Pull-Away™ receiver tubes when the snowplow is removed. It's quick, it's easy, and no tools are required. The clean, simple design doesn't overpower the appearance of your vehicle. *It just gives it a powerful look!*

NOTES

SPECIFICATIONS

E-60 - E-60H QUIK LIFT® POWER UNITS

TORQUE SPECIFICATIONS

	Thread Size	Torque (in Lbs.)
Reservoir Cover Retaining Nuts	5/16 - 24	100 - 125
Pump Assembly Bolts	3/8 - 16	180 - 220
End Plate of Valve Block		
Retaining Cap Screws	5/16 - 18	95 - 105
Cover Motor Mounting	5/16 - 16	96 - 120
Motor	1/4- 20	60 -72
Drain and Filter Plugs	9/16 - 18	75 -85

HYDRAULIC SPECIFICATIONS

PUMP

Pressure Output (pump relief valve setting)	2500 ± 50 P.S.I.
--	------------------

CROSSOVER RELIEF VALVE

Opening Pressure	3800 ± 400 P.S.I.
------------------	-------------------

HYDRAULIC FLUID CAPACITY

NOTE: 1 Quart = 32 Fluid Ounces

Model E-60

Unit	44 oz.
Hoses & 1-1/2" x 10" Cylinders	16 oz.
TOTAL	60 oz.

Model E-60

Unit	44 oz.
Hoses & 1-1/2" x 12" Cylinders	19 oz.
TOTAL	63 oz..

Model E-60H

Unit	48 oz.
Hoses & 1-1/2" x 10" Cylinders (Black)	16 oz.
TOTAL	64 oz..

Model E-60H

Unit	48 oz.
Hoses & 2" x 12" Cylinders	28 oz.
TOTAL	76 oz.

SPECIFICATIONS

E-57H ELECTRO-LIFT® POWER UNITS

TORQUE SPECIFICATIONS

	Thread Size	Torque (in Lbs.)
Reservoir Cover Retaining Nuts	5/16 - 24	100 - 125
Pump Assembly Retaining Nuts	5/16 - 24	100 - 125
End Plate or Valve Block Retaining Cap Screws	5/16 - 18	95 - 105
Motor to Pump Retaining Cap Screws	1/4 - 20	45 - 55
Drain and Filter Plugs	1/2 - 20	75 - 85

HYDRAULIC FLUID CAPACITY

NOTE: 1 Quart = 32 Fluid Ounces

Model E-57H

Unit	36.5 oz.
Hoses & 2" x 12" Cylinders	28 oz.
TOTAL	64.5 oz.

HYDRAULIC SPECIFICATIONS

PUMP

Pressure Output
(pump relief valve setting) 2000 P.S.I.

CROSSOVER RELIEF VALVE

Opening Pressure 3800 ± 400 P.S.I.

Owner Warranty Registration Card

Diamond Snow Plow Model:

- TM 6.5
- DTE 7.5
- DTE 8.0
- DTE 8.5
- DTE 9.0
- HML 10
- HM 10
- DAGT 10
- TMP 6.5
- TMP 7.0
- DTEP 7.5
- HMP 10
- MDII
- EZ MOUNT

Owner

Name _____

Address _____

City _____

State _____ Zip _____

County _____

Phone _____

Distributor or Dealer

Vehicle Equipment is Installed On:
Make _____
Model _____

Year _____

Name _____

Date of Installation _____

- E57H Out-Front Electric Hydraulics
- E47 Out-Front Electric Hydraulics
- E47H Out-Front Electric Hydraulics
- E60H Out-Front Electric Hydraulics

I purchased this Diamond Equipment

- From an automobile Dealer
- From a truck equipment distributor
- This is the first Diamond product I have owned.
- I have owned Diamond products in the past
- I have owned competitive brands in the past

What brands?

- Meyer
- Western
- Fisher
- Other

Principal use of this Diamond equipment

- Personal use only
- Contract snow removal
- Retail business property
- Industrial property

I heard about Diamond through

- Newspaper AD
- T.V. Ad
- Radio Ad
- Yellow Pages Ad
- Automotive Dealer
- Truck Equipment Distributor
- Friend

Which of the following most influenced your purchase of Diamond Equipment?

- Engineering & design features
- Price
- Previous experience or reputation



FOLD HERE



NO POSTAGE
NECESSARY
IF MAILED
IN THE
UNITED STATES



BUSINESS REPLY MAIL
First Class Mail Permit No. 696 Cleveland OH

Postage Will Be Paid By:
Diamond Equipment
a part of Meyer Products
18513 EUCLID AVENUE
CLEVELAND, OH 44112-9986

TWO YEAR WARRANTY

Diamond Equipment warrants to original purchaser only that it will repair, or at the sole option of Diamond Equipment replace any part of the new Diamond Equipment snowplow or any plow accessory which proves to be defective in workmanship or material under normal use for its intended purpose, that being plowing snow, for a period of two years from the date of delivery. This warranty is not transferable or assignable. The original purchaser's sole and exclusive remedy against Diamond Equipment and Diamond Equipments sole obligation for any and all claims, whether for breach of contract, warranty, tort (including negligence) or otherwise shall be limited to providing, through its authorized Distributor/Sub-Distributor network, all labor and/or parts necessary to correct such defects free of charge. Any cost incurred in returning the product to an authorized Distributor/Sub-Distributor is the responsibility of the original purchaser.

WARRANTY SERVICE

In order to obtain service under this warranty, the original purchaser must return the claimed defective part to the Distributor/Sub-Distributor from whom the product was purchased or to any authorized Diamond Equipment Distributor/Sub-Distributor, transportation and freight charges prepaid. Only Diamond Equipment Distributors/Sub-Distributors are authorized to perform the obligations under these warranties. For the address and telephone number of the Distributor/Sub-Distributor nearest you, check the telephone directory, Diamond web site distributor locator or you may write to Diamond Equipment at the address below.

GENERAL

It is the responsibility of the original purchaser to establish the warranty period by verifying the original delivery date. A bill of sale, cancelled check or some other appropriate payment record may be kept for that purpose. It is recommended, but not required, that the original delivery date be verified by immediately returning the attached Warranty Registration Card. No person is authorized to change this warranty or to create any warranty other than that set forth herein. This warranty gives you specific legal rights and you may also have other rights which vary from state to state.

EXCLUSIONS

THIS WARRANTY DOES NOT COVER PAINT OR EXPENDABLE SNOWPLOW PARTS SUCH AS PINS, RUNNERS, CUTTING EDGES, SPRINGS AND MARKERS. DIAMOND EQUIPMENT SHALL NOT BE LIABLE FOR ANY SPECIAL, INDIRECT OR CONSEQUENTIAL DAMAGES ARISING FROM ANY CLAIMS ARISING HEREUNDER, OR FOR DAMAGES RESULTING FROM LACK OF NECESSARY MAINTENANCE, FROM MISUSE, ABUSE, ACTS OF GOD, ALTERATION OF A DIAMOND EQUIPMENT PLOW OR PART, OR FROM USE OF PARTS OR HYDRAULIC FLUID NOT SUPPLIED BY DIAMOND EQUIPMENT. USE OF THE DIAMOND EQUIPMENT SNOW PLOW FOR ANY PURPOSE OTHER THAN PLOWING SNOW IS ONE EXAMPLE OF AN ABUSE AND MISUSE.

THE FOREGOING WARRANTY IS EXCLUSIVE AND IN LIEU OF ALL OTHER WARRANTIES, EXPRESS OR IMPLIED, INCLUDING, BUT NOT LIMITED TO, ANY IMPLIED WARRANTY OF MERCHANTABILITY OR FITNESS FOR A PARTICULAR PURPOSE.

For warranty information on Diamond Spreaders, Diamond Brooms or other Diamond Equipment, refer to the specific operation and maintenance manuals for those products.

DIAMOND EQUIPMENT

6 Angell Lane • Damariscotta, ME 04543-9801
www.diamondplow.com • e-mail info@diamondplow.com

