

# Slugger™ 2x2™

Slugger Portable Magnetic Drilling Machine

## OPERATOR'S MANUAL

### **WARNING!**

BEFORE USE, BE SURE EVERYONE USING THIS MACHINE READS AND UNDERSTANDS ALL SAFETY AND OPERATING INSTRUCTIONS IN THIS MANUAL.



EYE PROTECTION  
REQUIRED



HEARING PROTECTION  
REQUIRED



NEVER PLACE  
FINGERS NEAR  
CUTTING AREA OR  
MACHINE ARBOR

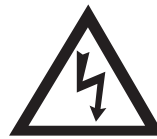

LINE VOLTAGE  
PRESENT



BEWARE OF  
ROTATING  
MACHINE PARTS



MODEL #17980 (120V) OR #17982 (240V)

Serial # \_\_\_\_\_

Date of Purchase \_\_\_\_\_

# Slugger™ Portable Magnetic Drilling Machine

Congratulations on your purchase of a Slugger™ portable magnetic drilling machine. Slugger drilling machines are designed to deliver fast, efficient hole drilling performance in portable applications. Please take a moment to complete and mail your product warranty registration card. Doing so will validate your machine's warranty period and ensure prompt service if needed. Thank you for selecting a Slugger product from Jancy Engineering Inc..

## TABLE OF CONTENTS

- Important Safety Instructions . . . . . 3-4
- Guideline for Shift Lever Position . . . . . 4
- Special Instructions . . . . . 5
- Grounding Instructions and Extension Cords . . . . . 6
- Contents of Package . . . . . 7
- Getting Started . . . . . 7
- Machine Operation . . . . . 8
- Basic Troubleshooting . . . . . 9
- Regular Maintenance . . . . . 10
- Machine Breakdown and Parts List . . . . . 11
- Arbor and Coolant Assembly Breakdown . . . . . 12
- Motor Breakdown . . . . . 13
- Motor Parts List . . . . . 14
- Wiring Diagram . . . . . 15
- Other Available Slugger Drills . . . . . 16

## LIMITED WARRANTY

Jancy Engineering Inc.™ will, within one (1) year from the original date of purchase, repair or replace any goods found to be defective in materials or workmanship, provided the product warranty registration card has been returned to Jancy Engineering Inc. within thirty (30) days of purchase date. This warranty is void if the item has been damaged by accident, neglect, improper service or other causes not arising out of defects in materials or workmanship. This warranty does not apply to machines and/or components which have been altered, changed, or modified in any way, or subjected to use beyond recommended capacities and specifications. Electrical components are subject to respective manufacturers' warranties. All goods returned defective shall be returned prepaid freight to Jancy, which shall be the buyer's sole and exclusive remedy for defective goods. In no event shall Jancy Engineering be liable for loss or damage resulting directly or indirectly from the use of merchandise or from any other cause. Jancy Engineering is not liable for any costs incurred on such goods or consequential damages. No officer, employee or agent of Jancy is authorized to make oral representations of fitness or to waive any of the foregoing terms of sale and none shall be binding on Jancy.

JANCY ENGINEERING RESERVES THE RIGHT TO MAKE IMPROVEMENTS AND MODIFICATIONS TO DESIGN WITHOUT PRIOR NOTICE.



## IMPORTANT SAFETY INSTRUCTIONS



WHEN USING ELECTRIC TOOLS, BASIC SAFETY PRECAUTIONS SHOULD ALWAYS BE FOLLOWED  
TO REDUCE RISK OF FIRE, ELECTRIC SHOCK AND PERSONAL INJURY.

### **READ AND SAVE ALL INSTRUCTIONS FOR FUTURE REFERENCE.**

1. **Keep Work Area Clean**
  - Cluttered areas and benches invite injuries.
2. **Consider Work Area Environment**
  - Do not expose power tools to rain.
  - Do not use power tools in damp or wet locations.
  - Keep work area well lit.
  - Do not use tool in presence of flammable liquids or gases.
3. **Guard Against Electric Shock**
  - Prevent body contact with grounded surfaces. For example: pipes, radiators, ranges and refrigerator enclosures.
4. **Keep Children Away**
  - Do not let visitors contact tool or extension cord.
  - All visitors should be kept away from work area.
5. **Store Idle Tools**
  - When not in use, tools should be stored in a dry, high and locked-up place, out of reach of children.
6. **Do Not Force Tool**
  - It will do the job better and safer at the rate for which it was intended.
7. **Use Right Tool**
  - Do not force a small tool or attachment to do the job of a heavy-duty tool.
  - Do not use tool for unintended purpose. For example: Do not use a circular saw for cutting tree limbs or logs.
8. **Dress Properly**
  - Do not wear loose clothing or jewelry. They can be caught in moving parts.
  - Non-skid footwear is recommended when working outdoors.
  - Wear protective hair covering to contain long hair.
9. **Use Safety Glasses**
  - Also use face or dust mask if cutting operation is dusty.
10. **Do Not Abuse Electrical Cord**
  - Never carry tool by cord or yank it to disconnect from receptacle.
  - Keep cord from heat, oil and sharp edges.
11. **Secure Work**
  - Use clamps or a vise to hold work. It's safer than using your hand and it frees both hands to operate tool.
12. **Do Not Overreach**
  - Keep proper footing and balance at all times.

## IMPORTANT SAFETY INSTRUCTIONS

### 13. Maintain Tools With Care

- Keep tools sharp and clean for better and safer performance.
- Follow instructions for lubricating and changing accessories.
- Inspect tool cords periodically and if damaged, have repaired by authorized service facility.
- Inspect extension cords periodically and replace if damaged.
- Keep handles dry, clean, and free from oil and grease.

### 14. Disconnect Tools

- Unplug when not in use, before servicing, and when changing accessories, such as bits and cutters.

### 15. Remove Adjusting Keys And Wrenches

- Form habit of checking to see that keys and adjusting wrenches are removed from tool before turning it on.

### 16. Avoid Unintentional Starting

- Do not carry a plugged-in tool. Always disconnect from power source before moving.
- Be sure switches are off before connecting to a power source.

### 17. Outdoor Use Extension Cords

- When tool is used outdoors, use only extension cords intended for use outdoors and so marked.

### 18. Stay Alert

- Watch what you are doing. Use common sense. Do not operate tool when you are tired.
- Do not use when taking medications that may cause drowsiness.

### 19. Check Damaged Parts

- Before further use of the tool, a guard or other part that is damaged should be carefully checked to determine that it will operate properly and perform its intended function.
- Check alignment of moving parts, binding of parts, breakage of parts, mounting, and any other conditions that may affect its operation. A guard or other part that is damaged should be properly repaired or replaced by an authorized service center.
- Do not use this tool if switches do not turn it on and off. Have defective switches replaced by authorized service center.

## GUIDELINE FOR 2X2 SHIFT LEVER POSITION





Cutter Diameter	1/2	5/8	3/4	7/8	1	1 1/8	1 1/4	1 3/8	1 1/2	1 5/8	1 3/4	1 7/8	2
Based on A-36 Steel													
Hi (420 rpm)													
Low (210 rpm)													



## SPECIAL INSTRUCTIONS

1. If you require an additional manual, please contact Jancy Engineering at (563) 391-1300 for a FREE copy.
2. Never place hands, fingers, gloves or clothing near cutting area or rotating machine parts.
3. Always disconnect machine from power source before changing cutters, clearing chips, refilling lubricant or performing adjustments.
4. Keep all safety features functioning and working properly.
5. Never wear loose clothing, gloves or jewelry when working near cutting area or rotating machine parts.
6. Always use eye and hearing protection.
7. Always use safety strap and chip guard provided with machine.
8. Always use proper tooling. Keep cutters securely fastened.
9. Do not use dull or broken cutters.
10. Do not use Slugger drilling machines on surfaces or materials being welded. Doing so can damage the machine's electrical components.
11. Beware of slugs ejected at end of cut. They become HOT during the cut.
12. Magnet will not hold properly on thin materials or rough and dirty surfaces.
13. Keep bottom of magnet burr free and clear of chips and debris.
14. To reduce the risk of electrical shock, do not use machine in wet or damp areas.
15. Do not remove or alter electrical panels. Use only authorized service centers for repairs.
16. Motor will not start on non-ferrous materials.

### **WARNING!**

DO NOT OPERATE MACHINE IF WARNING AND/OR INSTRUCTION LABELS ARE MISSING OR DAMAGED.  
CONTACT JANCY ENGINEERING FOR REPLACEMENT LABELS.

	<b>⚠ WARNING!</b>
	<p><b>ALWAYS USE EYE PROTECTION. ANY TOOL CAN SHATTER.</b></p> <p><b>LINE VOLTAGE PRESENT. TO REDUCE RISK OF ELECTRICAL SHOCK, THE USER MUST READ AND UNDERSTAND OPERATOR'S MANUAL.</b></p>
 	<b>⚠ CAUTION!</b>
	<p><b>ALWAYS WEAR HEARING PROTECTION. BEWARE OF EJECTED SLUG AT END OF CUT.</b></p>
<b>SAFETY INSTRUCTIONS</b>	
<ul style="list-style-type: none"> <li>• Read and follow operator's manual thoroughly. If you can not locate your operator's manual, call Jancy Engineering Inc. at 563.391.1300 for a free copy.</li> <li>• Always stop machine completely and disconnect from power source before changing cutters, performing adjustments or servicing.</li> <li>• Do not use altered, dull or broken cutters.</li> <li>• Never wear loose clothing or gloves when working near cutting area or machine arbor.</li> <li>• Always use provided safety strap and chip guard.</li> <li>• Use proper tooling. Keep cutters securely fastened.</li> <li>• Magnet will not hold properly on thin materials and rough or dirty surfaces. Keep magnet free of chips and debris.</li> <li>• Keep all safety features functioning and working properly.</li> <li>• Use only authorized service centers for repairs.</li> </ul>	







MOTOR

JANCY ENGINEERING INC.

2735 Hickory Grove Road  
Davenport, Iowa 52804  
Tel - 563.391.1300 or Fax - 563.391.2323



MAGNET

120V AC

**DANGER!**



**NEVER PLACE HANDS,  
FINGERS, GLOVES OR  
CLOTHING NEAR CUTTING  
AREA OR ROTATING  
MACHINE PARTS.**

## GROUNDING INSTRUCTIONS

### ⚠️ WARNING!

Improperly connecting the grounding wire can result in electrical shock. Check with a qualified electrician if you are in doubt as to whether the outlet is properly grounded. Do not modify the plug provided with tool. Never remove the grounding prong from the plug. If the cord or plug is damaged, have it repaired before using. If the plug will not fit the outlet, have a proper outlet installed by a qualified electrician. The 2x2 must be plugged into an appropriate outlet, properly installed and grounded in accordance with all codes and ordinances. The plug and outlet should look like those in Figure A.

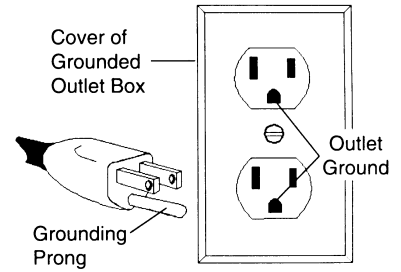

Fig. A

### ⚠️ WARNING!

DO NOT USE SLUGGER DRILLING MACHINES ON SURFACES OR MATERIALS BEING WELDED. DOING SO CAN RESULT IN PERSONAL INJURY AND/OR DAMAGE TO THE SLUGGER DRILLING MACHINE.

## EXTENSION CORDS

Use only 3-wire extension cords that have 3-prong grounding-type plugs and 3-pole receptacles that accept the tool's plug. Replace or repair damaged cords. Make sure your extension cord is in good condition. When using an extension cord, be sure to use one heavy enough to carry the current your product will draw. An undersized cord will cause a drop in line voltage resulting in loss of power and overheating. Jancy recommends using a minimum 12 gauge extension cord not to exceed 100 feet. The table below is supplied only as a guide to minimum gauge for extension cords, where the smaller the gauge number, the heavier the cord.

MINIMUM GAUGE FOR EXTENSION CORDS			
VOLTS	TOTAL LENGTH OF CORD IN FEET		
	120V	0-25	26-50
240V	0-50	51-100	
RECOMMENDED WIRE GAUGE			
AMPERAGE			
0-6	18	16	
6-10	18	16	
10-12	16	16	
12-16	14	12	

\*JANCY RECOMMENDS USING A MINIMUM 12 GAUGE EXTENSION CORD NOT TO EXCEED 100 FEET.

**DRIP LOOP:** To help prevent cutting fluids from traveling along power cord and contacting power source, tie a drip loop in power cord as shown in Figure B.

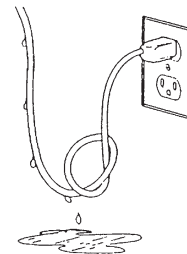

Fig. B

## OPERATING INSTRUCTIONS (BEFORE YOU BEGIN)

Remove all contents from packaging and inspect to ensure no damage was incurred during shipping. Your 2x2 package should include the following:

DESCRIPTION	PART #	QTY
OPERATOR'S MANUAL	LIT102B	1
SHUNT INSTRUCTIONS	06958	1
WARRANTY CARD	0070342	1
2.5 MM HEX KEY	0151255	1
4MM HEX KEY	70587	1
5MM HEX KEY	70588	1
6MM HEX KEY	058112	1
8MM COMBINATION WRENCH	0151219	1
KNOB AND SPOKE HANDLE	07018	3
SAFETY STRAP	06798	1
KNOCK-OUT WEDGE	07517	1
SAFETY AND MAINTENANCE CD	06814	1
#2MT ARBOR ASSEMBLY	07504	1
COOLANT BOTTLE ASSEMBLY	0151511	1
3/16" PILOT PIN 1" D.O.C.	16001	1
3/16" PILOT PIN 2" D.O.C.	16002	1
1/4" PILOT PIN 1" D.O.C.	16003	1
1/4" PILOT PIN 2" D.O.C.	16004	1

## GETTING STARTED



### CAUTION!

ALWAYS DISCONNECT 2x2 FROM POWER SOURCE BEFORE MAKING ADJUSTMENTS.

Assemble three spoke handles (item #404) to feed hub. **NOTE:** Feed hub assembly is mounted on right side of machine frame—if necessary, it can be reversed for lefthand operation by simply removing the fastener (item #402) and hub (item #401) from frame. Remove hub pinion shaft from right side of frame and insert it into left side of frame. Replace hub and fastener into frame and tighten securely.

Install the arbor into the drill motor by inserting the arbor body into the spindle. By turning the arbor while inserting, the arbor tang will properly line up in the spindle. The stop rod (item #911) should be between the inducer pin (item #904.3) and the hose connection (item #904.2) when properly installed. Turn the arbor until it bottoms out in the spindle and then tap lightly with a plastic hammer to secure.

To install coolant bottle, use bracket (item #611) to slide the coolant bottle onto the two retaining screws (item #614), located on the right side of drill. Install the free end of hose onto hose connection (item #904.2) on the arbor.

## WHAT YOU SHOULD KNOW BEFORE YOU DRILL

1. Type of material to be drilled, Brinnell or Rockwell hardness, material thickness and position should all be determined to ensure proper selection of Slugger cutting tools, RPM, coolant and drilling time.
2. Remove any excessive mill scale or rust from surface to be drilled.
3. Material that has been flame cut may have become heat-treated and therefore difficult to drill. Avoid drilling near such areas whenever possible.
4. Drilling with the 2x2 in horizontal positions requires a special lubrication for Slugger cutters. Consult Jancy Engineering for details.

## BEFORE THE CUT

1. Select correct pilot pin and place in cutter shank from the rear, align flats on cutter shank with arbor body set screws, insert cutter into arbor body.
2. Tighten set screws securely on cutter shank flats. **NOTE:** Set screws should be recessed in arbor body when tight.
3. The surface you are working on should be clean and flat, free from rust, scale, dirt and chips.
4. Fill coolant reservoir with a water-soluble coolant.
5. Place Slugger machine on workpiece with pilot pin over the center of hole to be drilled.
6. Connect machine to power source.
7. Lower Slugger cutter to surface of material to be cut. Coolant will be released down the pilot into center of Slugger cutter. Coolant flow can be stopped by lifting pilot pin off work surface. **NOTE:** Be sure coolant valve is open. Regulate coolant flow by adjusting coolant valve.

### **CAUTION!**

ALWAYS USE SAFETY STRAP. FAILURE TO DO SO COULD RESULT IN PERSONAL INJURY AND/OR DAMAGE TO THE SLUGGER DRILLING MACHINE.

8. The safety strap must be securely fastened to machine and around work being drilled. Loop strap around work piece and connect strap ends by attaching to D-rings on drill. **NOTE:** Safety strap is intended only to restrain the drill to the work piece in the event of a power failure to the magnetic base.
9. Position chip guard toward work area before drilling.

## READY TO MAKE THE CUT

### **CAUTION!**

POSITION CHIP GUARD BEFORE DRILLING.

1. Move magnet switch to "ON" position. Switch will illuminate to indicate power is present—magnetic base should be firmly secured to workpiece at this time. Thin materials may require an additional steel plate to achieve proper magnet adhesion.
2. Start drill motor by depressing green motor "ON" button.
3. Using the feed handles, advance cutter into material until Slugger cutter has established an external groove in the material during the remainder of cut apply smooth constant pressure without overloading motor. **NOTE:** Slugger cutters are designed for uninterrupted cutting. Chips are evacuated during the cut. Do not peck drill when using Slugger cutters.

### **CAUTION!**

IF DRILL MOTOR SHOULD STALL OR STOP BEFORE A COMPLETE CUT IS MADE, ALWAYS REMOVE CUTTER FROM HOLE BEFORE ATTEMPTING TO RESTART MOTOR. FAILURE TO DO SO COULD RESULT IN PERSONAL INJURY AND/OR DAMAGE TO THE SLUGGER DRILLING MACHINE OR CUTTER. **NOTE:** THIS MACHINE'S CIRCUITRY WILL AUTOMATICALLY SHUT THE DRILL MOTOR OFF IF MAGNETIC BASE IS SEPARATED FROM ITS WORK SURFACE. IF YOUR MACHINE'S CIRCUITRY IS NOT FUNCTIONING CORRECTLY, CONTACT JANCY'S SERVICE DEPARTMENT.

## AFTER THE CUT

1. After Slugger cutter has finished the cut, the "slug", or uncut center portion of material, will be expelled when motor is returned to the full up position.
2. Return machine into full upright position and depress red motor "OFF" button, wait until motor completely stops.
3. Move magnet switch to "OFF" position when ready to release magnetic base from work surface. Due to residual magnetism it may take a few seconds for magnet to release completely.



## BASIC TROUBLESHOOTING

1. **Magnetic base not holding securely**
  - Material is too thin to engage magnet.
  - Surface of material being drilled must be free of chips, debris, rust and mill scale.
  - Does size of cutter exceed machine's rated capacity?
  - Check magnet face for unevenness, nicks and burrs.
  - Is welding equipment connected to material being drilled?
2. **Drill motor running, arbor and spindle not turning**
  - Possible sheared spindle key.
3. **Motor slows when drilling**
  - Is an extension cord being used? If so, see page 6 for recommended wire gages and cord lengths.
  - Excessive downfeed pressure during drilling cycle will cause motor to slow and overheat.
  - Does cutting tool need to be resharpened?
4. **Coolant system not working**
  - Coolant system is gravity dependent, machine must be in a upright position to operate properly.
  - Check operation of coolant valve. Valve must turn freely.
  - Check coolant lines for blockage.
  - Dirt or debris in coolant tank.
  - Consistency of coolant mixture too thick.
  - Is correct pilot pin being used?
  - Vent hole in coolant tank lid blocked.
5. **Slugs not ejecting from cutter**
  - Lack of coolant causing slugs to expand in cutter bore.
  - Is correct pilot pin being used?
  - Possible broken internal arbor parts.
6. **Breaking cutters**
  - How is coolant being applied? Coolant must be supplied to interior of cutter.
  - Excessive feed pressure being applied when cutter initially contacts work surface.
  - Confirm material hardness.
  - Drilling stacked materials with incorrect cutter.
  - Dull cutters; dull or chipped cutting edges require excessive feed pressure, resulting in breakage.
  - Excessive arbor runout—see regular maintenance on page 10.
  - Improperly adjusted motor slide—see page 10.
7. **Oversized or rough holes**
  - Insufficient coolant.
  - Excessive feed pressure.
  - Dull cutter.
  - Excessive arbor runout—see regular maintenance on page 10.
  - Motor slide improperly adjusted.

## REGULAR MAINTENANCE

1. The motor slide may require adjustment after machine has been in service. Loosen jam nuts using provided wrench. Using feed handles, position motor/slide assembly in the full up position. Using supplied hex key, equally turn adjustment screws clockwise to increase slide tension or counterclockwise to decrease slide tension. Do not over tighten adjustment screws. Excessive slide tension can damage the machine. Properly adjusted, the motor/slide assembly should have no side to side movement and remain in the fully up position without drifting down.
2. Keep bottom of magnet clean, free of chips, burrs, nicks, oil and other contaminants. Inspect magnet face to ensure surface is flat and square. A worn magnet surface dramatically reduces magnetic holding force.
3. Periodically lubricate motor slide ways with lithium base grease.
5. Arbor runout should not exceed .0035 inches per revolution. This is most accurately measured by placing a dial indicator needle inside of arbor bore and rotating arbor while observing indicator.
6. Inspect motor brushes and replace as needed.
7. Replace any worn parts and regularly tighten fasteners that have become loose during usage.
8. Regularly test machine by placing machine on non-ferrous material. Engage magnet switch. Motor should not continue running when motor on button is released.

DIMENSIONS AND SPECIFICATIONS	
Height	21"
Width	8"
Length	12"
Weight	36-1/4 lbs.
Motor	1.6 HP 1200W (single phase) 120V / 10.2A ~ 240V / 5.1A 210 / 420 RPM (no load)
Spindle Bore	#2 morse taper
Arbor Bore	3/4"
Drill Point Breakaway	1111 lbs. on 1" plate
Magnet Base Dimensions	3-1/2" x 8"
Magnet Dead Lift	2657 lbs. on 1" plate
Slugger Cutter Diameter (Maximum)	2"
Slugger Depth of Cut (Maximum)	2"

NOTE: MAGNETIC BASE REQUIRES 1" MINIMUM MATERIAL THICKNESS WHEN DRILLING 1-3/8" AND LARGER DIAMETER HOLES

# MACHINE PARTS LIST

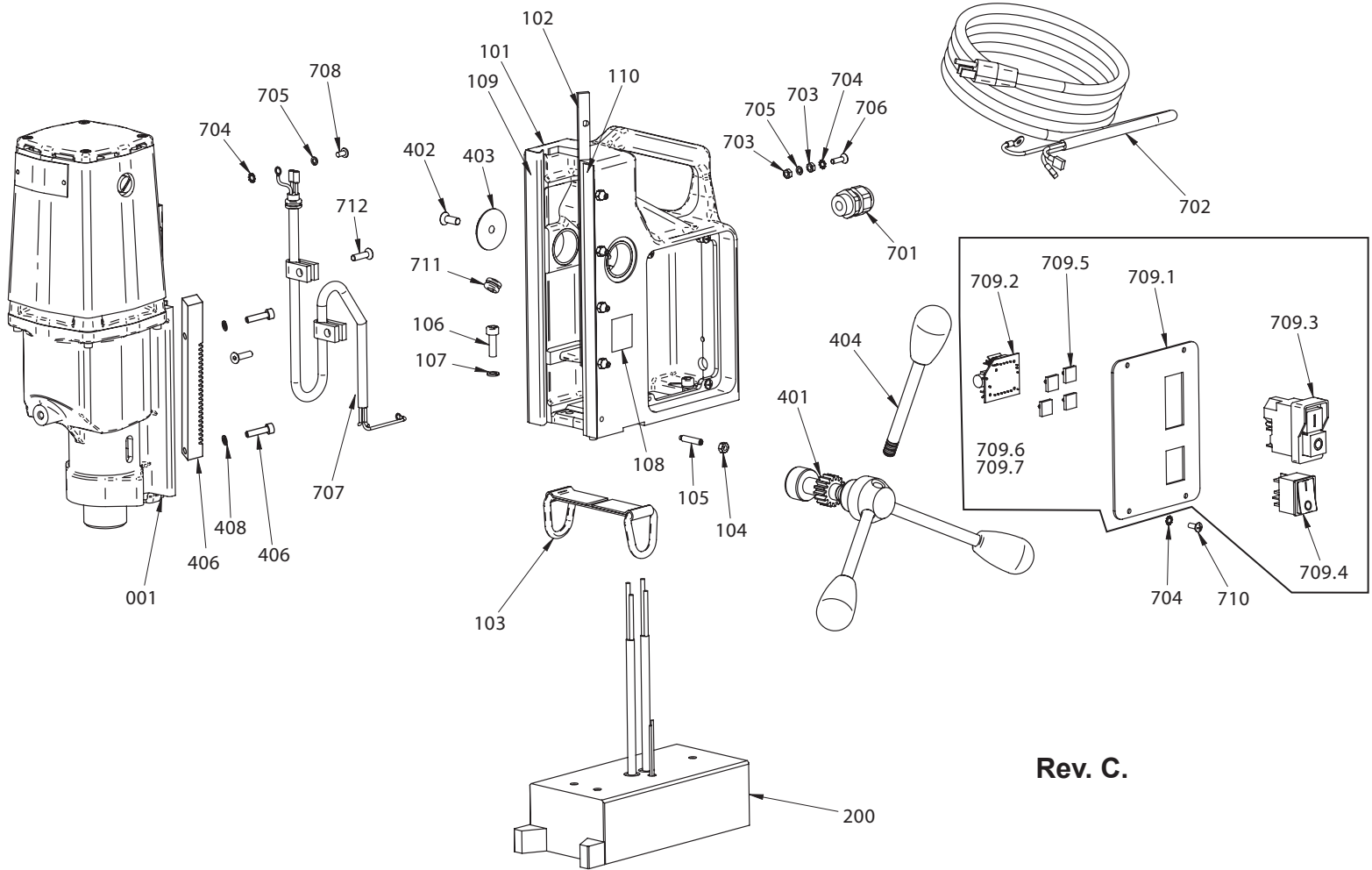

**Rev. C.**

ITEM	DESCRIPTION	PART #	QTY
001	MOTOR ASSEMBLY 120V	07201	1
	MOTOR ASSEMBLY 240V	07203	1
101	FRAME	07205	1
102	PRESSURE PLATE	07004	1
103	D-RING STRAP	06796	1
104	NUT, M5	0151181	5
105	SSS, M5 X 25	07020	5
106	SHCS, M6 X 20	0014102	3
107	WASHER, SPLIT M6	07016	3
108	LABEL, GIB ADJUSTMENT	07503	1
109	SLIDE INSERT (LEFT)	07251	1
110	SLIDE INSERT (RIGHT)	07252	1
200	MAGNET	07017	1
401	PINION	07019	1
402	FHSCS, M6 X 20	080404	1
403	HUB WASHER	07006	1
404	SPOKE HANDLE	07018	3
406	GEAR RACK 6-3/8" LONG	07024MT2	1
407	SHCS, M5 X 20	06774	2
408	WASHER, SPLIT M5	07023	2
701	STRAIN RELIEF	015064	1

ITEM	DESCRIPTION	PART #	QTY
702	POWER CORD 120V	06564	1
	POWER CORD 220V	CALL	1
703	NUT, M4	0070133	2
704	WASHER, LOCK M4	06773	6
705	WASHER, SPLIT M4	080720	2
706	FHSCS, M4 X 16	07116	1
707	MOTOR CORD ASSEMBLY	07239	1
708	CRPHMS, M4 X 8	04820	1
709	CONTROL PANEL ASSY.	07206	1
709.1	PANEL PLATE WITH LABEL	07207	1
709.2	CIRCUIT BOARD 120V	07294	1
	CIRCUIT BOARD 240V	07295	1
709.3	MOTOR SWITCH	07208	1
709.4	MAGNET SWITCH-4 CONNECTOR	BM507	1
709.5	LOCKING PILLAR	07209	4
709.6	WIRE GROUP 1-NOT SHOWN	07210	1
709.7	WIRE GROUP 2-NOT SHOWN	07211	1
710	CRPHMS, M4 X 10	080710	4
711	GROMMET, RUBBER 3/8" STYLE 2	07117	1
712	FHSCS, M5 X 20	07212	2

# MACHINE PARTS LIST

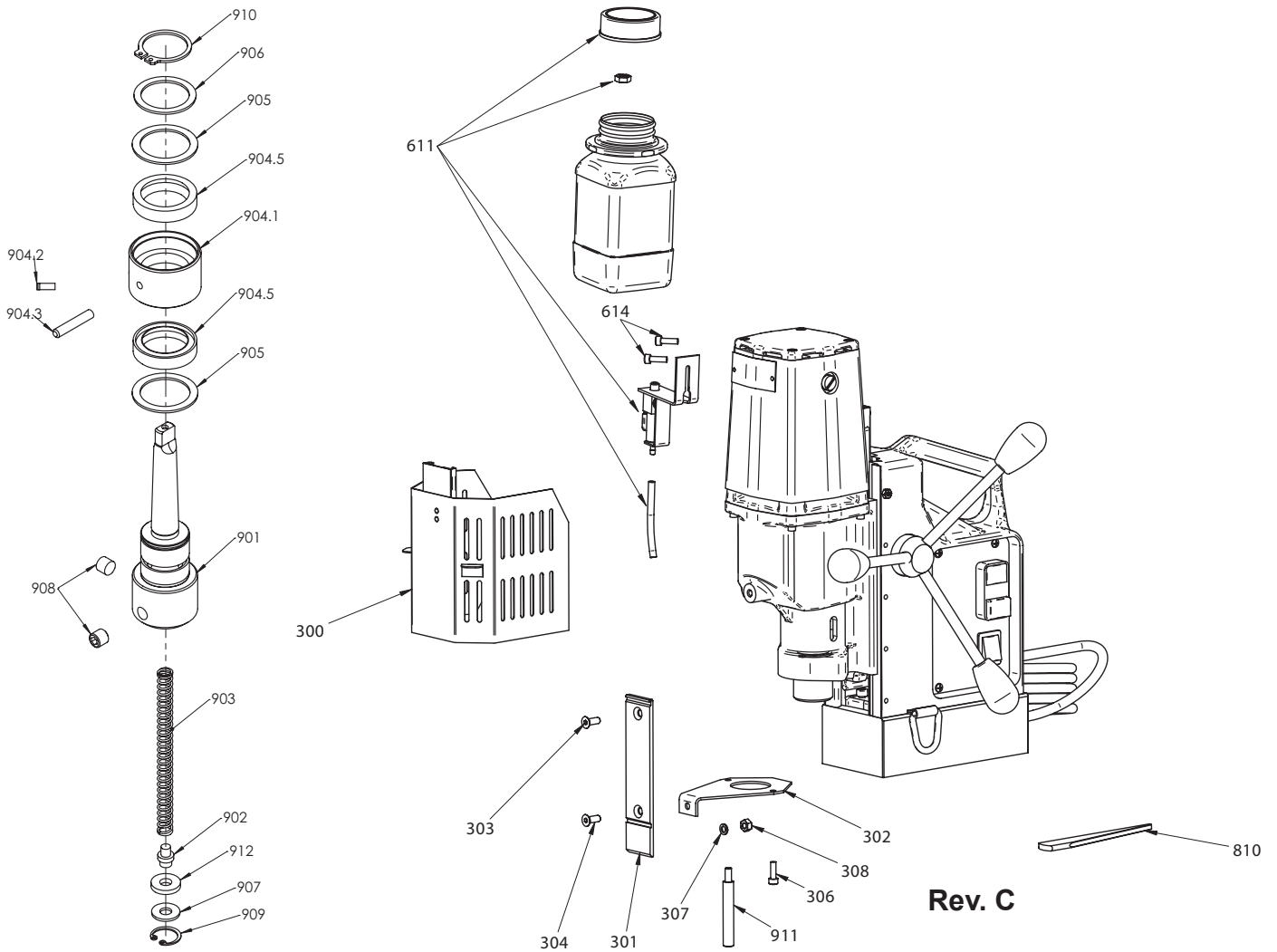

**Rev. C**

ITEM	DESCRIPTION	PART #	QTY
300	CHIP GUARD ASSEMBLY	07026	1
301	GUIDE PLATE	07213	1
302	FLANGE PLATE	07214	1
303	SCR, FHSCS M6 X 12	054140	1
304	SFHMS, M6 X 20	05MT404	1
306	SHCS, M6 X 12	0070535	1
307	WASHER, SPLIT M6	07016	1
308	NUT, M6	070308	1
611	BOTTLE ASSEMBLY	0151511	1
614	SHCS, M4 X 12	06770	2
810	KNOCK-OUT WEDGE	07517	1
900	ARBOR ASSEMBLY	07504	1
901	ARBOR BODY	07505	1

ITEM	DESCRIPTION	PART #	QTY
902	PLUNGER	07530	1
903	SPRING	07507	1
904.1	COOLANT INDUCER	07508	1
904.2	HOSE CONNECTION	07529	1
904.3	INDUCER PIN	07510	1
904.5	SEAL	07511	2
905	WASHER	07512	2
906	SPACER	07513	1
907	WASHER	07533	1
908	SSS, M10 X 10	07336	2
909	RETAINING RING, INTERNAL 19W	0215067	1
910	RETAINING RING, EXTERNAL 32Z	07215	1
911	STOP ROD, M6	07216	1
912	RUBBER WASHER	07531	1

# MOTOR PARTS

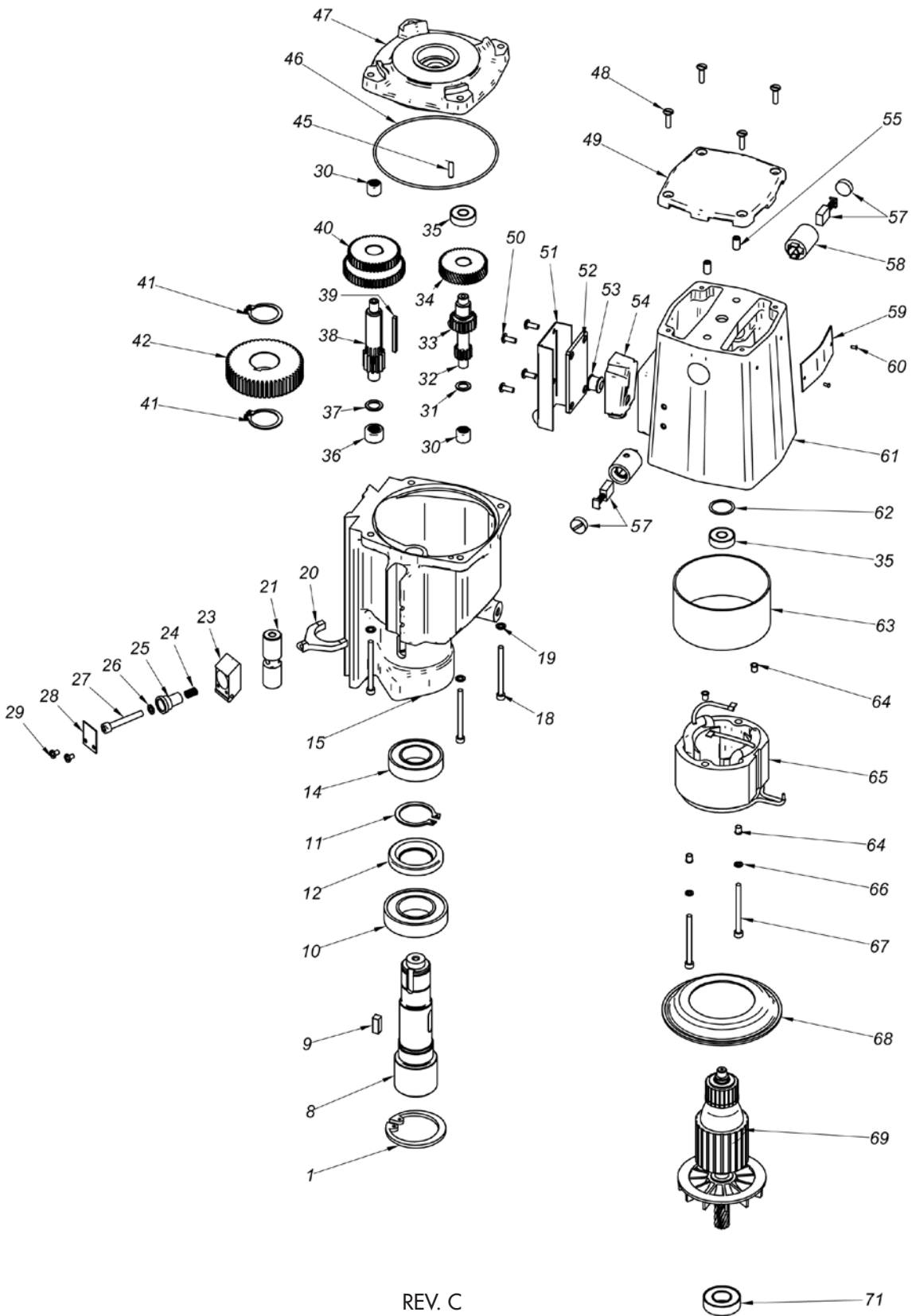

REV. C

## MOTOR PARTS LIST

ITEM	DESCRIPTION	PART #	QTY
1	RETAINING RING, INTERNAL 55W	07128	1
8	SPINDLE	07129MT2	1
9	KEY, SQUARE 6 X 6 X 15	07127	1
10	BEARING, 6006	07126	1
11	RETAINING RING, EXTERNAL 30Z	07125	1
12	SEAL, SPINDLE 28 X 47 X 7	07518	1
14	BEARING, 6005	07122	1
15	GEAR CASE	07259	1
18	SHCS, M5 X 30	03097	4
19	WASHER, SPLIT M5	07023	4
20	SHIFT FORK	07146	1
21	SHIFT PIN	07145	1
23	SHIFT LEVER	045014	1
24	SPRING	04591	1
25	SHIFT COLLAR	04524	1
26	WASHER, INTERNAL M5	04563	1
27	SHCS, M5 X 35	04572	1
28	TAG, SHIFT	04514	1
29	CRPHMS, M3 X 5	045793	2
30	BEARING, NEEDLE RHINA 081210	07151	2
31	WASHER, THRUST 8, 1	07158	1
32	GEARSHAFT, 12T/20T	07157	1
33	KEY, WOODRUFF 3 X 3.7	07156	1
34	GEAR, HELICAL 46T	07155	1
35	BEARING, 608	04544	1
36	BEARING, NEEDLE RHINA 101610	07147	1
37	WASHER, THRUST 10, 1	07148	1
38	GEARSHAFT, 12T	07149	1
39	KEY, SQUARE 3 X 3 X 36	07161	1
40	GEAR, DUAL 52T/44T	07150	1
41	RETAINING RING, EXTERNAL 25Z	07152	2
42	GEAR, 52T	07162	1
45	PIN, DOWEL 4 X 16	07160	1
46	O-RING	07153	1
47	COVER, GEAR CASE	07154	1
48	SFHMS, M4X16	07116	4
49	COVER, FIELD CASE	07115	1
50	CRPHMS, M4 X 8	04820	4
51	COVER, CORD	07120	1
52	PLATE, CORD	07119	1
53	SNAP BUSHING, LA6	07441	1
54	LINER, COVER	07118	1
55	SSS, M6 X 12	0070526	2
57	BRUSH SET	04550	2
58	BRUSH HOLDER	04551	2
59	TAG, MOTOR 120V	07027	1
	TAG, MOTOR 240V	07028	1
60	DRIVE SCREW, #2 X 3/16	0070028	2
61	FIELD CASE	07113	1
62	WASHER, SPRING	04560	1
63	INSULATOR, FIELD	05010	1
64	INSULATOR, FIELD SCREW	04557	4
65	FIELD 120V	06580	1
	FIELD 240V	06584	1
66	WASHER, INTERNAL M4	04576	2
67	SHCS, M4 X 50	07106	2
68	SHROUD	07105	1
69	ARMATURE 120V	04644	1
	ARMATURE 240V	04645	1
71	BEARING, 6002	07101	1

REV. C

# WIRING DIAGRAMS

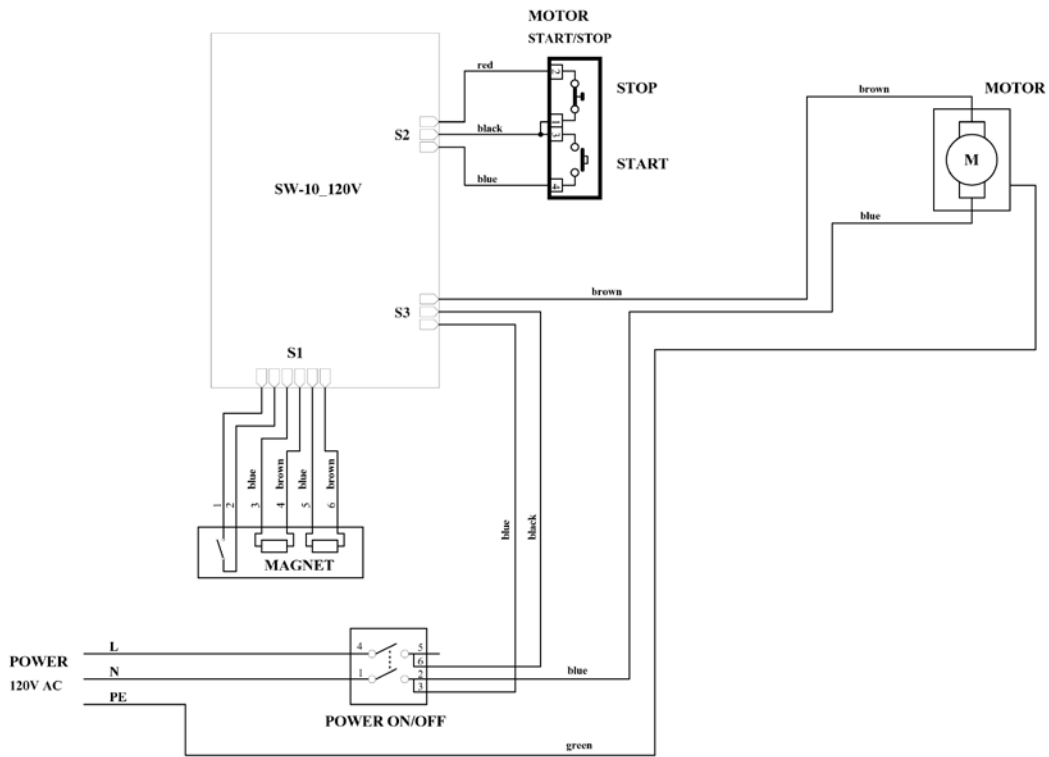

## WIRING DIAGRAM PART #07294

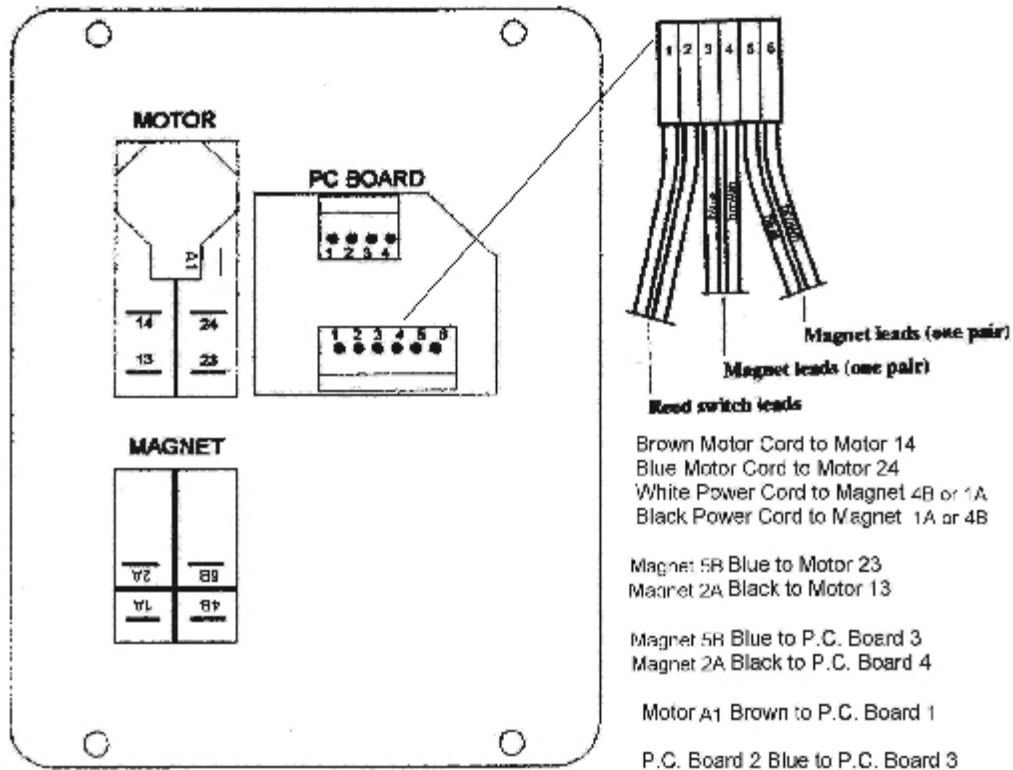

Rev. C

## OTHER AVAILABLE SLUGGER DRILLS

DESCRIPTION	MODEL #	MAX DIAMETER	CAPACITY	DEPTH
USA5 120V	18066	2-3/8"		3"
USA5 240V	18080	2-3/8"		3"
JM101 120V	19020	1-3/8"		2"
JM101 240V	19024	1-3/8"		2"
JM101 120V WITH 3/8" SLIDE BAR FEED HANDLE	19021	1-3/8"		2"
2 X 2 120V	17980	2"		2"
2 X 2 240V	17982	2"		2"
4 X 4 120V	17985	4"		3"
4 X 4 240V	17987	4"		3"
MAGFORCE 120V	06920	1-3/8"		2"
MAGFORCE 240V	06921	1-3/8"		2"

YOUR DISTRIBUTOR



Tel · 563.391.1300 or Fax · 563.391.2323  
2735 Hickory Grove Road · Davenport, Iowa 52804  
email · [jancy@jancy.com](mailto:jancy@jancy.com) / web · [jancy.com](http://jancy.com)