



**DANGER**



THIS TOOL FOR USE BY LICENSED OPERATORS ONLY.  
READ AND OBEY ALL SAFETY AND OPERATING  
INSTRUCTIONS BEFORE OPERATING TOOL.



**Ramset**<sup>®</sup>  
*POWDER FASTENING SYSTEMS*

## MODEL 721 TOOL

OPERATOR'S  
SAFETY &  
OPERATING  
INSTRUCTION  
MANUAL

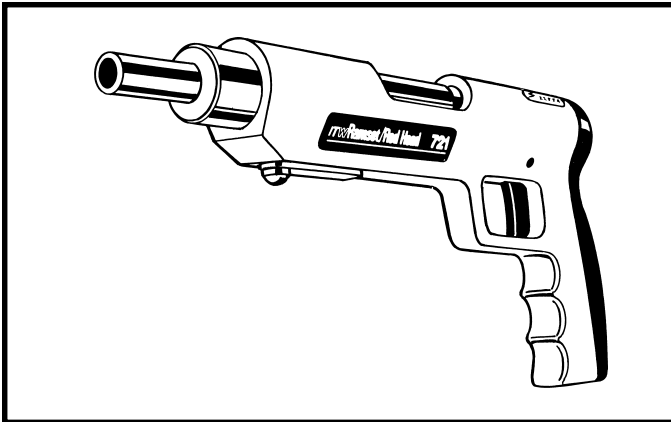

SINGLE SHOT, LOW VELOCITY  
PISTON TYPE FASTENING TOOL

**TW Ramset/Red Head**

## SAFETY INTRODUCTION



**DANGER**



**DANGER**



**THIS TOOL IS TO BE USED ONLY BY PROPERLY TRAINED AND LICENSED OPERATORS. YOU MUST SUCCESSFULLY COMPLETE ITW RAMSET/RED HEAD'S TRAINING PROGRAM FOR THE TOOL AND OBTAIN A CERTIFIED OPERATOR'S LICENSE BEFORE HANDLING, LOADING OR OPERATING THIS TOOL.**

**ATTEMPTING TO HANDLE OR OPERATE THIS TOOL WITHOUT PROPER TRAINING AND LICENSING CAN RESULT IN SERIOUS INJURY TO THE OPERATOR OR BYSTANDERS.**

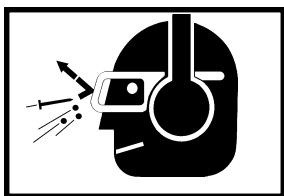

**Operator's and bystanders must wear eye and hearing protection.**



**Read manual before operating tool.**

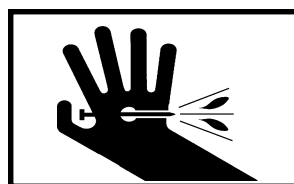
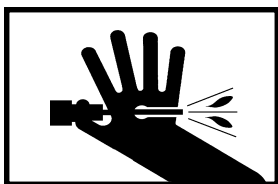

**Never close tool with hand over fastener loading end of the tool. A serious hand injury from penetration by the piston or a discharged fastener could result.**



**DANGER**



Just as no one can merely read a book about driving an automobile and then hope to drive one safely, no one should attempt to use any Ramset tool without adequate, competent personal instruction. And just as one must be licensed to drive an automobile, one must also be licensed to use a powder actuated tool. No automobile instruction book or instructor can forewarn a learner against all possibilities and emergencies, nor can ITW Ramset/Red Head instructors and printed material detail all possible conditions surrounding the use of ITW Ramset/Red Head tools and products. **Responsibility for the safe and proper use of this tool rests with the tool user and the employer.**

## SAFETY INTRODUCTION



**DANGER**

## Preparation

### Acceptable Base Materials

Powder actuated fastening is suitable for use in the following base materials only:

- Poured Concrete
- Structural Steel
- Masonry Joints ( see page 8)

Never attempt to fasten into any other type of material. *Fastening into other materials can cause blindness or other serious injury.*

### Unacceptable Base Materials

Never attempt to fasten into very hard or brittle materials such as cast iron, tile, glass, or rock of any type.

*These materials can shatter, causing the fastener and/or base material fragments to fly free and cause serious injury to the tool operator and others.*

Never fasten into soft base materials, such as drywall or lumber products. *These materials may allow the fastener to travel completely through and out the other side, endangering those in the path of the fastener.*

Never fasten into any base material that does not pass the Center Punch test. *Failure to assure the suitability of the base material can result in serious injury to the eyes or other body parts.*

## Center Punch Test

**ALWAYS WEAR SAFETY GOGGLES WHEN PERFORMING THIS TEST.**

1. Always check the material being fastened into for hardness before attempting any fastening operation.
2. Using a fastener as a center punch, strike the fastener against the work surface using an average hammer blow and check the results.

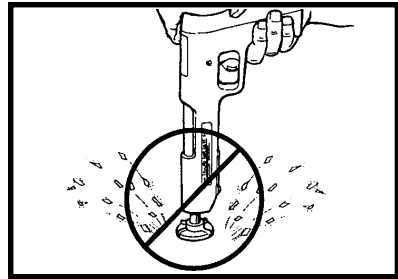

**NEVER FASTEN INTO VERY HARD OR BRITTLE MATERIALS**

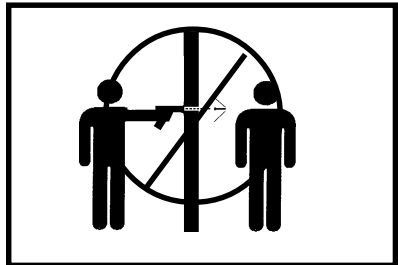

**NEVER FASTEN INTO SOFT MATERIALS SUCH AS DRYWALL**

### Center Punch Test Results

1. If the fastener point is flattened, the material is too hard for a powder actuated fastening.
2. If the fastener penetrates the material easily, the material is too soft.
3. If the material cracks or shatters, the material is too brittle.
4. If the fastener makes a small indentation into the material, the material is suitable for fastening.

## SAFETY INSTRUCTIONS

 **DANGER**

### Loads & Load Selection Safety

1. Always make a test fastening after being sure that the base material is suitable for powder actuated fastening. Failure to determine the correct power level to be used may result in the use of excessive power, allowing the fastener to pass completely through the work material, causing serious or fatal injuries to others who may be in the path of the fastener.
2. Color-blind operators must always select loads by load number to prevent use of an incorrect load for the same reasons as in #1 above.

### Workplace Safety

1. Operators and bystanders must always wear approved safety goggles and approved hearing protection. Failure to do so may result in blindness or serious eye injury from flying debris and loss of hearing from constant or repeated unprotected exposure to fastening noise.
2. Always keep the work area clear of bystanders and unnecessary materials that could interfere with safe tool operation. Operating the tool in a congested or cluttered area may affect your ability to operate the tool safely.
3. Never operate tool if flammable or explosive materials are nearby. Powder loads burn and create sparks when fired and could ignite these materials or fumes.
4. Always post warning signs within 50' of the area where fastening is to be done. Sign must state: "Caution- Powder Actuated Tool In Use". Failure to warn others may result in serious injury to them. Contact ITW Ramset/ Red Head at 1-800-354-7432 to obtain this sign.

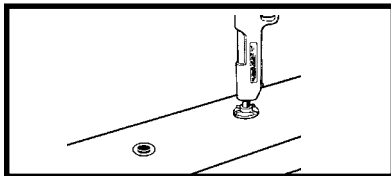

**ALWAYS MAKE A TEST FASTENING**

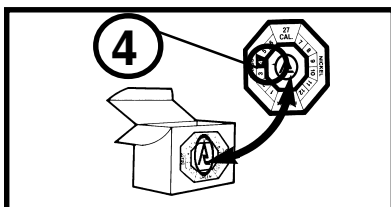

**COLOR-BLIND OPERATORS MUST ALWAYS SELECT LOADS BY NUMBER**



**KEEP WORK AREA CLEAR OF BYSTANDERS AND CLUTTER**



**NEVER OPERATE TOOL AROUND FLAMMABLE OR EXPLOSIVE MATERIALS**



**ALWAYS POST WARNING SIGNS**

## SAFETY INSTRUCTIONS

 **DANGER**



## DANGER

## SAFETY INSTRUCTIONS

### Tool Handling Safety

1. Always be sure tool is operating properly before attempting to use it. Follow the "Daily Function Check" shown to the right and described on page 9.
2. Always load tool using a power load selected directly from a box indicating the power load type and number. Never attempt to use loose loads that could be mis-identified.
3. Never carry loose loads in pockets with pins or other hard objects.
4. Never load a tool unless you intend to immediately make a fastening. *Loading a tool and leaving it unattended in the work area can result in the tool being accidentally discharged by others.*
5. Never place your hand or any other body part over the fastener loading end of the tool. *Serious hand injury could result from being struck by either a fastener or the tool piston should the tool be accidentally fired.*
6. Always store the tool unloaded and keep the tool and the loads securely locked in a tool box. Keep keys away from children and unlicensed persons.
7. Always keep the tool pointed away from yourself and others.
8. Never carry a loaded tool around the work area.
9. Never allow anyone not trained to use the tool.
10. Never engage in horseplay with the tool.
11. Using the tool in poorly ventilated areas, cleaning tool or handling loads may result in exposure to lead or other substances known to cause birth defects, and other physical harm. Have adequate ventilation at all times and wash thoroughly after exposure.

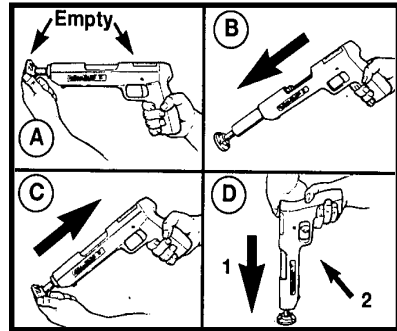

**ALWAYS DO A DAILY  
FUNCTION CHECK BEFORE  
LOADING TOOL**

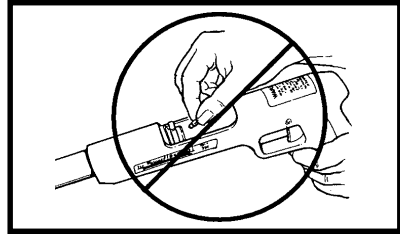

**NEVER LOAD TOOL UNLESS IT  
IS TO BE USED IMMEDIATELY**

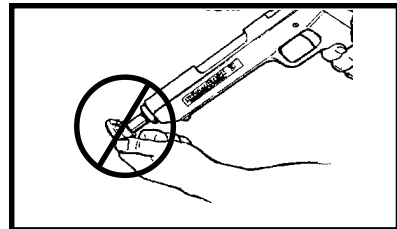

**NEVER PLACE HANDS OR  
BODY OVER MUZZLE OPENING**

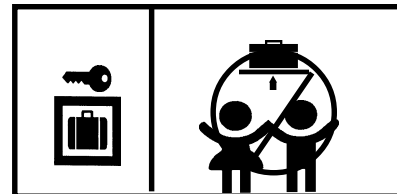

**KEEP TOOL LOCKED & OUT OF  
THE REACH OF CHILDREN**

## SAFETY INSTRUCTIONS



## DANGER

**FAILURE TO FOLLOW INSTRUCTIONS CAN CAUSE INJURY TO THE TOOL OPERATOR OR TO BYSTANDERS.**

**Fastener Driving Safety**

1. Only use the tool for fastening into a suitable base material.
2. Never fire the tool without a fastener. *Firing a tool without a fastener will cause the piston to strike the work surface, and may cause serious injury to you and others in the work area.*
3. Always use the spall guard whenever possible to minimize flying particles or debris.
4. Always hold the tool perpendicular to and firmly against the work surface when making a fastening. *Failure to do so could allow a fastener to ricochet.*
5. Never attempt to drive a fastener close to an edge or to another fastener. *See page 8 for guidelines.*

**ALWAYS FOLLOW THE MISFIRE PROCEDURE**

If the tool does not fire after pulling the trigger, continue to hold the depressed tool against the work surface for at least 30 seconds. Then carefully open the tool, remove the load, and put it in a can of water or other non-flammable liquid. Never carelessly discard live loads into a trash container. **If the tool becomes stuck or jammed with a live powder load, keep the tool pointed in a safe direction, and immediately tag it, "Danger-defective-do not use".** Lock the tool in a tool box and call your local Ramset Distributor for assistance.

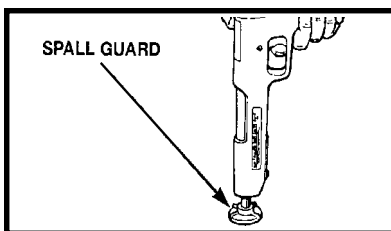

**USE SPALL GUARD WHENEVER POSSIBLE**

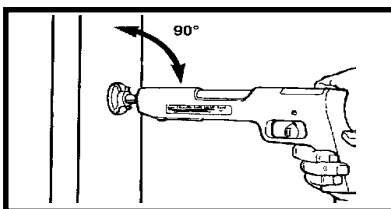

**ALWAYS HOLD TOOL PERPENDICULAR TO WORK SURFACE**

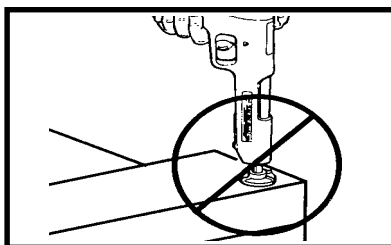

**NEVER DRIVE A FASTENER CLOSE TO AN EDGE**

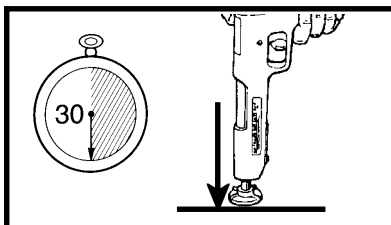

**HOLD THE TOOL FIRMLY AGAINST THE WORK SURFACE FOR AT LEAST 30 SECONDS.**

# FASTENERS / LOADS

Your Ramset Model 721 tool uses only the Ramset fasteners and loads shown below or listed for the tool in the Product Catalog .

**DANGER**

Never use any other types of fasteners or loads in the Model 721 tool. Use of other types of fasteners or loads may cause unintentional load discharge, damage the tool, cause poor fastening performance, or create a risk of serious injury to the operator or bystanders.

## FASTENERS

### .300 HEAD PLASTIC FLUTED DRIVE PINS



.145 Shank Diameter in Shank lengths from 1/2" to 1 1/2"

### 1/4"-20 Threaded studs



.145 Shank Diameter in Shank Lengths of 1/2" and 1" and thread lengths of 1/2", 3/4" and 1". Maximum overall fastener length is 1 1/2" for the Model 721 tool .

### .300 HEAD TOP-HAT DRIVE PINS



.145 Shank Diameter in Shank Lengths from 1/2" to 1"

### CONDUIT CLIP ASSEMBLIES

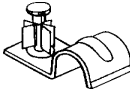

For 1/2" and 3/4" Diameter Conduit with 1" premounted fastener

### .300 HEAD PLASTIC FLUTED DRIVE PINS WITH 7/8" WASHER

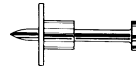

.145 Shank Diameter in Shank Lengths from 1" to 2"

### .300 HEAD POWER POINT PLASTIC FLUTED DRIVE PINS



.150 Straight Shank in Shank Lengths from 1/2" to 7/8"  
.150 / .180 Step Shank in Lengths from 1" to 1 1/4"

### CEILING CLIP ASSEMBLIES

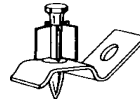

Ceiling Clip with 1" or 1-1/4" premounted .145 shank pin and Ceiling Clip with 1" or 1-1/4" premounted .150/.180 shank pin.

## LOADS

Ramset .22 cal. CW loads are specially made for use in the Model 721 Tool.

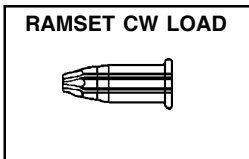

The power level of the loads is indicated by the number marked on each box, the color of the box and the color on the tip of each load. As the number increases, the power level also increases.

Always perform the center punch test described on page 3 to test the base material.

POWER LEVEL	CATALOG NUMBER	LOAD COLOR	CASE COLOR
1	12 CW	Gray	Brass
2	22 CW	Brown	Brass
3	32 CW	Green	Brass
4	42 CW	Yellow	Brass

Always make a test fastening using the #1, Gray, power level first. If more power is required to set the fastener, use the next higher power level until the power level necessary to drive the fastener is reached.

# FASTENERS / LOADS

---

## FASTENING APPLICATIONS

### FASTENING APPLICATIONS

Your Ramset tool can be used for a wide range of fastening needs in a variety of base materials. Reading and following these important fastening guidelines will help you get the best results from your tool, fasteners, and powder loads, as well as help you perform these fastening operations safely and effectively.

Powder actuated fastenings are permanent fastenings so attempting to remove a fastener from concrete or steel may result in a serious injury.

### Fastening to Concrete

When fastening into concrete, always maintain a minimum spacing of 3" between fastenings and 3" from any free edge. Concrete thickness should be at least three times the intended penetration depth into the concrete. The primary exception to the 3" edge distance can occur in a sill plate application where, by necessity, the edge distance is reduced.

Driving fasteners too close to an edge or too close to each other can cause the concrete edge to fail or fasteners to fly free.

### Fastening to Concrete Block or to Masonry Walls

While this application is not recommended, when used, it is necessary to take care to observe a 3" edge distance to avoid cracking the block and over penetration of the fastener to avoid a loss of holding value. Fastenings may be made into the horizontal joint but not into the vertical joint.

### Fastening to Steel

Your Ramset tool can be used for fastening on the flat surfaces of structural steel. When fastening into steel, always maintain a minimum spacing of 1-1/2" between fastenings and 1/2" from any edge.

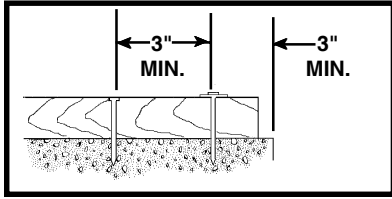

**SPACING  
WOOD TO CONCRETE**

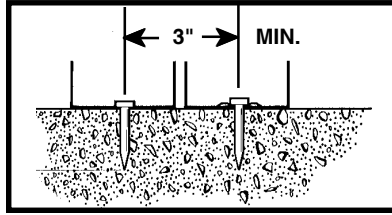

**PENETRATION - THIN GAUGE  
METAL TO CONCRETE**

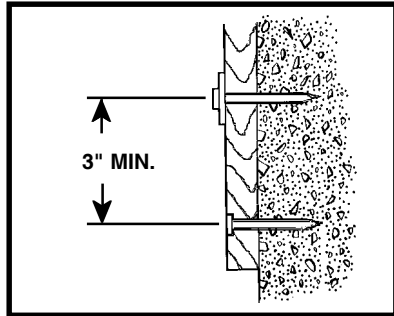

**SPACING - FURRING  
STRIP TO CONCRETE**

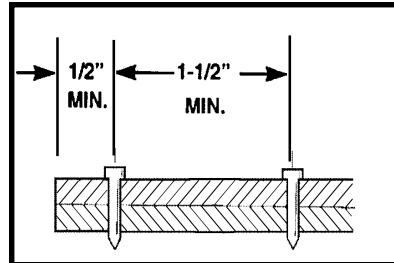

**SPACING  
STEEL TO STEEL**

---

## FASTENING APPLICATIONS



---

## TOOL OPERATING INSTRUCTIONS

### TOOL OPERATION

#### Daily Function Test

**Always check the tool first to make sure that it does not contain a load or fastener.** Test the tool several times by depressing the muzzle bushing fully on a hard surface and pulling the trigger. You should hear an audible click as the firing pin releases. Let up on the tool and check to be sure that the barrel has opened to the semi-closed position.

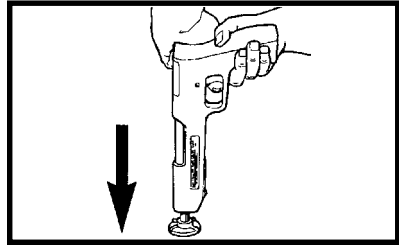

**PERFORM FUNCTION TEST WITH EMPTY, UNLOADED TOOL**

### OPERATING THE MODEL 721

1. After checking to be sure that the tool is not loaded, point it in a safe direction and snap the barrel open with a quick downward motion. This action positions the piston in preparation for the next fastening. Use the spall guard every time possible to minimize the risk of being struck by flying debris.

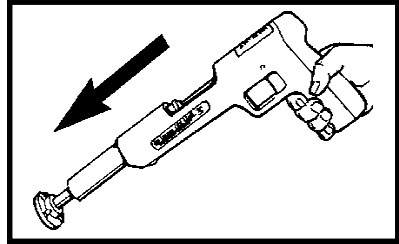

**SLIDE THE BARREL FORWARD**

2. With finger off the trigger, place the fastener, point out, into the muzzle end of the tool until the point end is inside the muzzle. **NEVER** load a fastener with your finger on the trigger. **DO NOT** use excessive force when inserting a fastener. **STOP** immediately if excessive force is required, inspect the barrel to find out why the fastener is not entering the muzzle freely. **DO NOT** continue loading unless the problem is corrected.

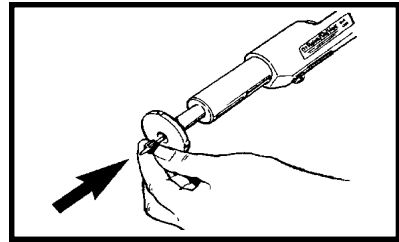

**INSERT FASTENER INTO THE MUZZLE END OF THE TOOL WITH THE POINT OUT**

3. With the tool pointed in a safe direction, the barrel fully open, and your finger away from the trigger, make sure the chamber is clear and insert a load into the tool chamber. Always start with the #1, gray power level. If the #1 load does not fully set the fastener, try the next higher power level until the proper power level is found.

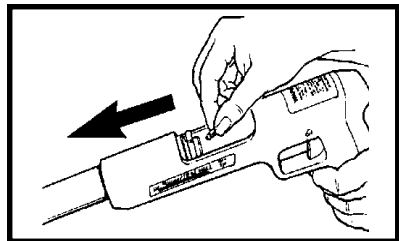

**INSERT A LOAD INTO THE TOOL CHAMBER**

---

## TOOL OPERATING INSTRUCTIONS

## TOOL OPERATING INSTRUCTIONS

---

- Slide the barrel back to the semi-closed position. **Never** attempt to close the tool by exerting force on the front end of the barrel. **Never place your hand, fingers or any other body part over the fastener loading end of the tool.**
- Hold the tool perpendicular (90°) to the work surface with both hands and press firmly to fully depress the tool. Maintain firm downward pressure on the tool with both hands and pull the trigger to drive the fastener. **DO NOT DEPRESS THE TOOL AGAINST ANYTHING OTHER THAN THE INTENDED WORK SURFACE.** Holding the tool firmly in place will produce more consistent fastening quality and minimize tool wear or damage.
- After making the fastening, point the tool in a safe direction, and snap the tool downward to cause the barrel to move to the open position. This action ejects the fired load case and properly resets the piston for the next fastening. Should a fired load fail to eject, open and close the tool several times to loosen the load in the chamber, then remove the load with your fingers. **Never attempt to pry an unfired load out of the tool chamber.** The load could be caused to discharge resulting in a serious injury or death to the tool operator or to a bystander.
- Insert another fastener in the muzzle end of the tool before inserting a new powder load into the chamber. **Always insert the fastener into the tool before inserting the powder load.** Keep your finger off of the trigger until the tool is in position to drive the fastener. **Never carelessly discard or throw unfired powder loads into a trash container.**

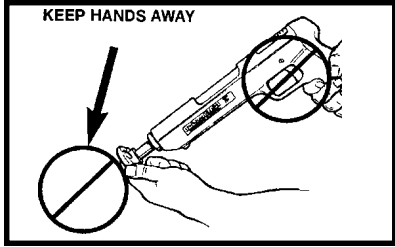

**SLIDE THE BARREL BACKWARD TO THE SEMI-CLOSED POSITION**

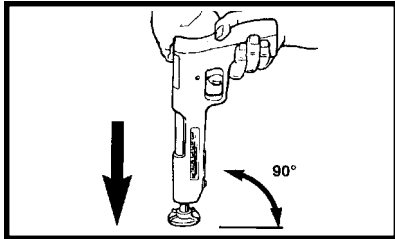

**HOLD TOOL FIRMLY AND PERPENDICULAR TO THE WORK SURFACE**

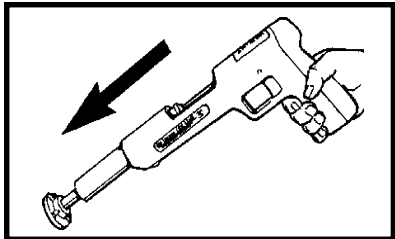

**EJECT THE LOAD**

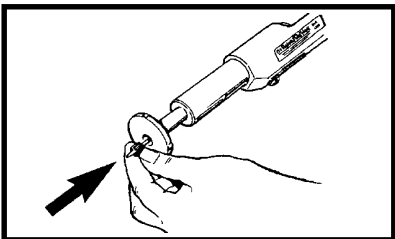

**INSERT THE NEXT FASTENER**

## TOOL OPERATING INSTRUCTIONS

---

# TROUBLESHOOTING

## REFER TO PARTS SCHEMATIC FOR PROPER ASSEMBLY OF PARTS

- Overdriving of fasteners	- Excessive power	- Change to next lower power level load color and number.
	- Soft base material	- Check base material (see page 3)
- Tool fails to fire	- Failure to depress completely	- See " Tool does not completely depress"
	- Excessive dirt buildup on breech face not allowing proper penetration of firing pin	- After following misfire procedure, check firing pin indentation on load and clean breech face.
	- Firing pin and/or breech damaged	- Replace damaged parts
- Tool does not completely depress	- Misassembled or damaged parts	- Check all parts in the receiver for damage or improper assembly.
- Reduction or loss of power	- Piston not being returned to the full rear position	- The barrel must be pulled completely open to properly position the piston.
	- Worn or damaged piston or piston ring	- Replace missing, worn or damaged parts.
	- Worn or broken stop pin	- Replace stop pin
- Fired load will not extract	- Tool not being fully opened	- Barrel must be pulled out fully to allow piston tip to eject the load case.
	- Damaged or bent piston	- Replace piston
	- Loose breech plug	- Tighten breech plug
	- Dirt buildup in the breech	- Clean breech
	- Stuck powder load	- Remove barrel assembly from tool and unscrew the breech plug. Gently push out load using a brass rod. DANGER: If the load has not been fired, use extreme care to avoid causing the load to discharge.
- Piston stuck in down position	- Piston overdriven and stuck in piston stop	- Tap on a hard surface or drive back with brass or lead hammer.
- Barrel opens too easily	- Stop pin spring is too weak	- Replace spring
Barrel will not slide open or is very hard to open	- Bent piston	- Replace piston
	- Excessive dirt buildup	- Disassemble & clean tool
	- Stop pin damaged	- Replace stop pin
	- Debris jammed between barrel and receiver housing.	- Disassemble & remove debris
- Chipped or damaged piston tip	- Tool not being held squarely to the work surface. This allows the piston to slip off of the head of the fastener and cause a piston tip damage.	- Grind the end of the piston as shown on page 15. Grinding should only be done by a qualified individual.

# TROUBLESHOOTING

**PARTS SCHEMATIC**

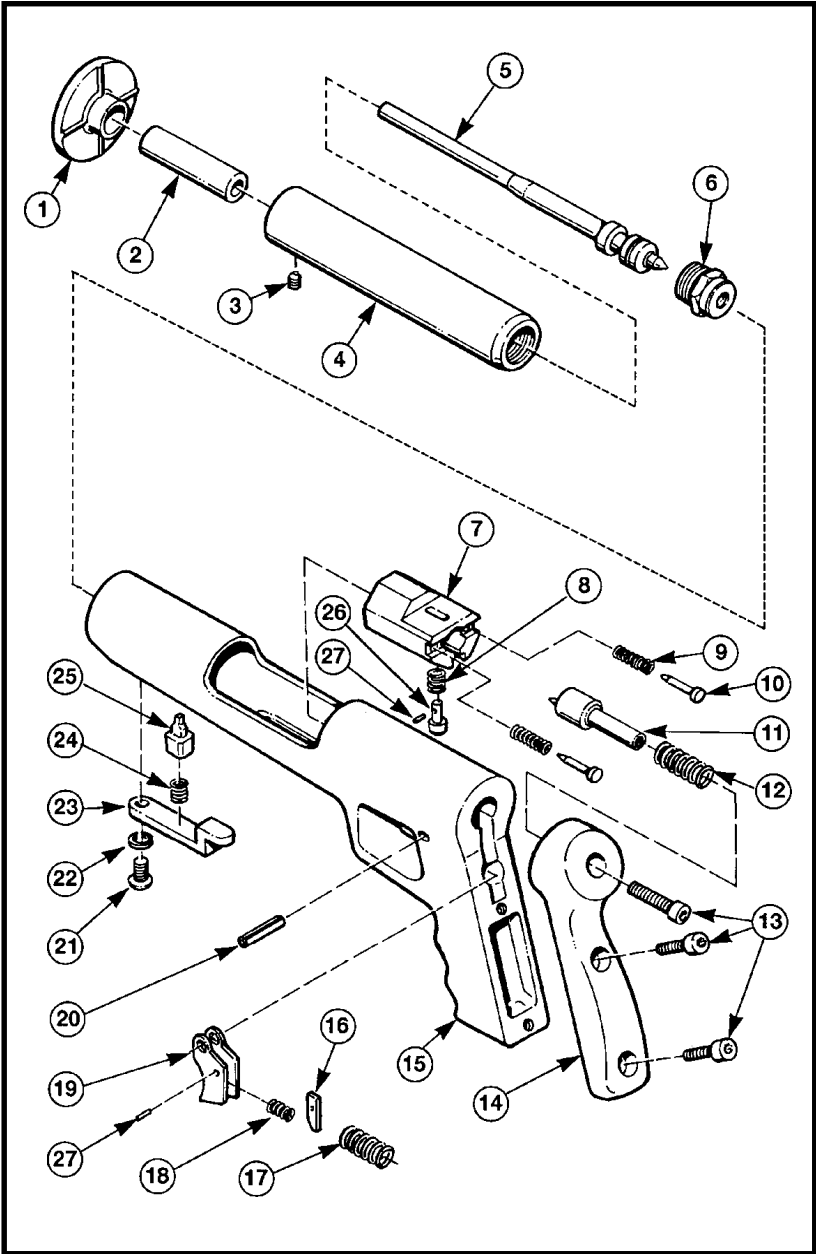

**PARTS SCHEMATIC**

# PARTS LISTING / MAINTENANCE

## MODEL 721 TOOL PARTS LIST

KEY	PART NO.	DESCRIPTION
1	12266	SPALL GUARD
2	12258	BARREL EXTENSION
3	12260	BARREL EXTENSION SCREW
4	12108	BARREL ASSEMBLY
5	33657	PISTON/RING ASSEMBLY
6	33650	BREECH PLUG
7	33640	BREECH BLOCK
8	33659	SEAR SPRING
9	33642	BREECH BLOCK SPRING (2)
10	33641	BREECH BLOCK SPRING PIN (2)
11	12085	FIRING PIN
12	33658	FIRING PIN SPRING
13	33674	HANDLE/FIRING PIN SCREW (3)
14	81681	RUBBER HANDLE ASSEMBLY
15	22101	HOUSING ASSEMBLY
16	33667	TRIGGER BAR
17	33647	TRIGGER SPRING
18	33668	TRIGGER BAR SPRING
19	33646	TRIGGER
20	12476	TRIGGER ROLL PIN
21	22798	STOP PIN COVER SCREW
22	22790	LOCK WASHER
23	22088	STOP PIN COVER
24	12388	STOP PIN SPRING
25	33645	STOP PIN
26	81649	SEAR
27	33671	SEAR/TRIGGER BAR ROLL PIN (2)

### MAINTENANCE

**IMPROPERLY MAINTAINED TOOLS CAN CAUSE SERIOUS INJURIES TO  
TOOL OPERATORS AND BYSTANDERS**

**CLEAN TOOL DAILY**

**Always** make sure the tool is not loaded before performing any service or repair and always wear safety goggles when cleaning or servicing the tool.

### NORMAL CLEANING

All front end parts shown in the disassembly section are to be cleaned daily with a good detergent oil and wire brush. Remove all dirt and carbon buildup and wipe parts dry with a clean rag. Check all parts for wear or damage before reassembly and replace or repair any worn or damaged parts.

### COMPLETE CLEANING / GENERAL MAINTENANCE

Heavy use or constant exposure to dirt and debris may require that the tool be cleaned more extensively. Complete disassembly and cleaning of all parts may be necessary to restore the tool to normal operation. General maintenance should be performed every six months or more often if the tool is subjected to heavy use. Contact your authorized Ramset Distributor for assistance.

**ALWAYS FUNCTION TEST THE TOOL AFTER PERFORMING ANY SERVICE.  
SEE PAGE 9 FOR DETAILS ON THE FUNCTION TEST.**

## PARTS LISTING / MAINTENANCE

# DISASSEMBLY

---

## TOOL DISASSEMBLY

1. Remove the screw and lockwasher from the stop pin cover using the 5/32" hex wrench provided with the tool.

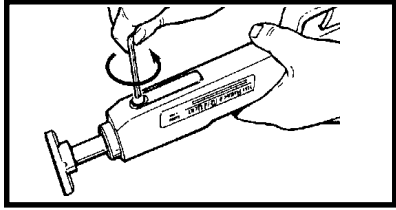

**REMOVE STOP PIN COVER,  
SCREW & LOCKWASHER**

2. Remove the stop pin cover by lifting it up and out of the tool housing.

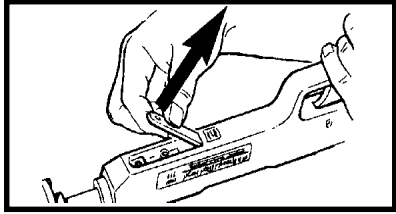

**REMOVE STOP PIN COVER**

3. Remove the stop pin spring.

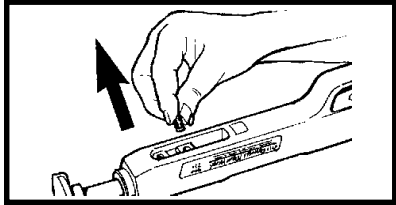

**REMOVE STOP PIN SPRING**

4. Remove the stop pin.

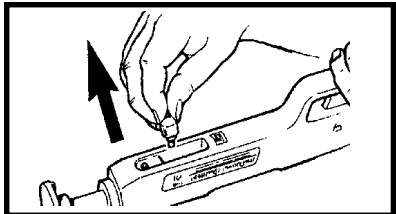

**REMOVE THE STOP PIN**

5. Slide the barrel assembly out of the tool housing. Note the alignment of the slot in the barrel with the stop opening in the tool housing.

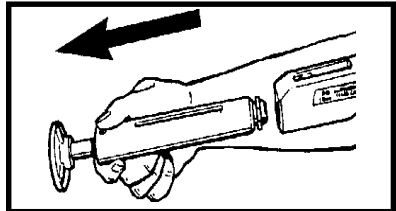

**SLIDE THE BARREL OUT OF THE  
TOOL HOUSING**

---

# DISASSEMBLY

## DISASSEMBLY

6. Unscrew the breech plug from the rear of the barrel using a 1" wrench. Protect the barrel from damage if a vise is used to hold the barrel during the disassembly.
7. Slide the piston out of the barrel assembly. If necessary, tap the breech plug end of the barrel on a wood block to free the piston.
8. Inspect all parts for wear or damage and clean or replace as required. Use detergent oil and cleaning brush. Wipe parts dry before reassembly. **WEAR SAFETY GOGGLES WHEN CLEANING TOOL PARTS.**
9. Check the piston tip for mushrooming or other deformities, and grind flat. The tip of the piston must be 90° to the shank and grinding should only be done by qualified personnel. The overall minimum length of the piston must not be less than 6 1/16". When less than this length, the piston must be replaced to avoid tool damage.
10. Inspect all tool parts for wear or damage and clean or replace as required. Wipe all parts dry before reassembly.
11. Reassemble the tool in the reverse order of disassembly. Align the stop groove in the barrel with the stop opening in the tool housing when replacing the barrel.

**ALWAYS PERFORM THE DAILY FUNCTION TEST BEFORE USING THE TOOL AFTER CLEANING OR SERVICING.**

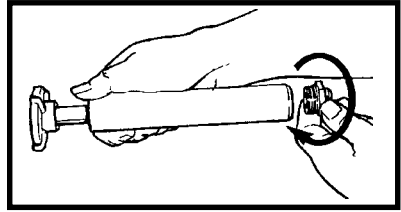

**UNSCREW THE BREECH PLUG FROM THE BARREL**

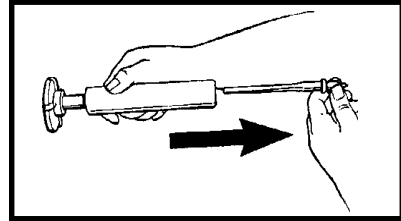

**SLIDE THE PISTON FROM THE REAR OF THE BARREL**

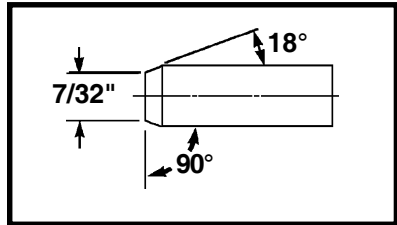

**GRIND THE PISTON TIP FLAT AND BEVEL EDGE AT 18°**

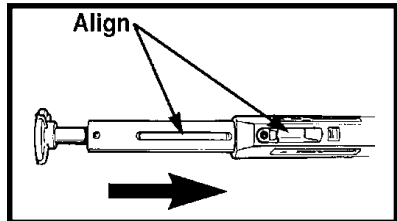

**ALIGN STOP GROOVE IN THE BARREL WITH STOP OPENING**

## DISASSEMBLY

## WARRANTY

ALL WARRANTIES OF THE PRODUCTS DESCRIBED HEREIN, EXPRESSED OR IMPLIED, INCLUDING THE WARRANTY OF MERCHANTABILITY AND FITNESS FOR PARTICULAR PURPOSES, ARE SPECIFICALLY EXCLUDED, EXCEPT FOR THE FOLLOWING: Ramset will repair or replace, at its sole option, any tool, part, or fastener which, within 90 days after sale by Ramset, is found by Ramset to be defective in material or workmanship, normal wear and tear excluded. **THIS IS THE SOLE WARRANTY OF RAMSET AND THE SOLE REMEDY AVAILABLE TO THE BUYER AND IN NO EVENT WILL ANY DIRECT OR INDIRECT INCIDENTAL OR CONSEQUENTIAL DAMAGES, OR ANY OTHER DAMAGES, BE AVAILABLE.**

Copyright 1999 ITW Ramset/Red Head



THE MODEL 721 TOOL COMPLIES WITH OSHA REQUIREMENTS  
AND WITH ANSI A10.3 SPECIFICATIONS

FOR TOOL REPAIR SERVICE CONTACT YOUR LOCAL  
AUTHORIZED ITW RAMSET/RED HEAD DISTRIBUTOR OR CALL  
THE ITW RAMSET/RED HEAD TOOL REPAIR DEPARTMENT AT  
1-800-354-7432



Concrete Fastening Systems  
Wood Dale, IL 60191  
(630) 350-0370

Buy With Confidence ....  
Buy From Your Authorized Diistributor

© ILLINOIS TOOL WORKS 1999

PRINTED IN THE U.S.A.  
REVISED 12/99