

NOTE:
Please read all instructions
carefully before using this
product

Safety Notice

Hardware Identifier

Assembly Instruction

Parts List

Warranty

Ordering Parts

Model
IGS-07

Retain This
Manual for
Reference

04-22-02

OWNER'S
MANUAL

IRON GRIP **SPORT**TM

IGS-07 MULTI LAT/MID/LOW Machine

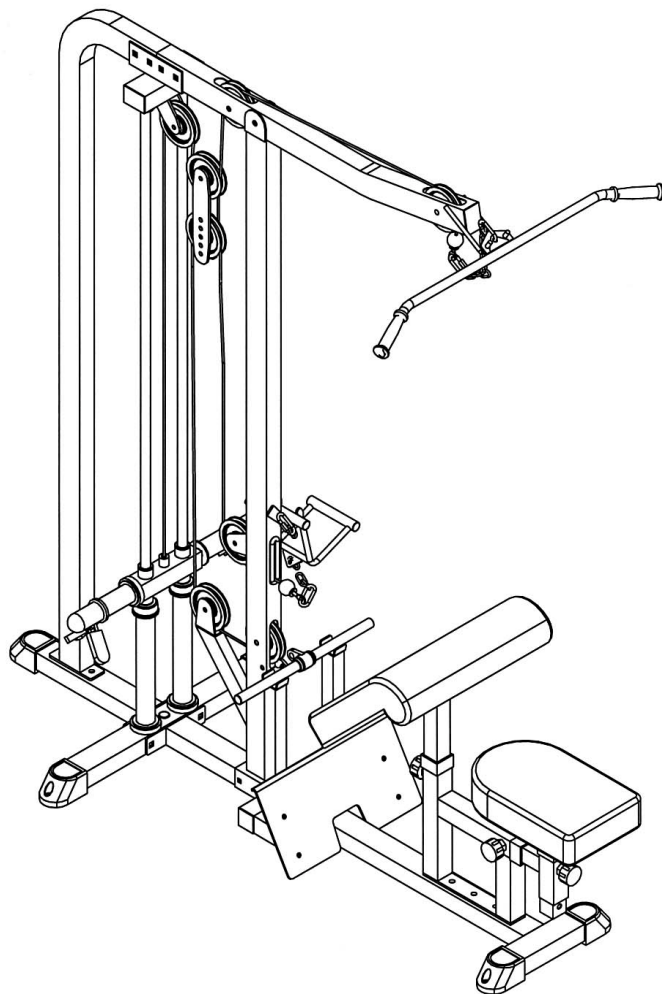

IMPEX FITNESS PRODUCTS

14777 DON JULIAN RD., CITY OF INDUSTRY, CA 91746

Tel: (800) 999-8899 Fax: (626) 961-9966

www.impex-fitness.com

info@impex-fitness.com

TABLE OF CONTENTS

BEFORE YOU BEGIN.....	1
IMPORTANT SAFETY NOTICES.....	2
HARDWARE IDENTIFIER.....	3
ASSEMBLY INSTRUCTIONS.....	4
EXPLODED DIAGRAM.....	11
PARTS LIST.....	12
WARRANTY.....	13
ORDERING PARTS.....	13

BEFORE YOU BEGIN

Thank you for selecting the IRON GRIP SPORT IGS-07 Multi Lat/Mid/Low Machine by IMPEX FITNESS PRODUCTS. For your safety and benefit, read this manual carefully before using the machine. As a manufacturer, we are committed to provide you complete customer satisfaction. If you have any questions, or find there are missing or damaged parts, we guarantee you complete satisfaction through direct assistance from our factory. To avoid unnecessary delays, *please call our TOLL-FREE customer service number.* Our Customer Service Agents will provide immediate assistance to you.

Toll-Free Customer Service Number

1-800-999-8899

Mon. - Fri. 9 a.m. - 5 p.m. PST

www.impex-fitness.com

info@impex-fitness.com

IMPORTANT SAFETY NOTICE

PRECAUTIONS

This exercise machine is built for optimum safety. However, certain precautions apply whenever you operate a piece of exercise equipment. Be sure to read the entire manual before you assemble or operate your machine. In particular, note the following safety precautions:

1. **Keep children and pets away from the machine at all times. DO NOT leave children unattended in the same room with the machine.**
2. Only one person at a time should use the machine.
3. If the user experiences dizziness, nausea, chest pain, or any other abnormal symptoms, STOP the workout at once. CONSULT A PHYSICIAN IMMEDIATELY.
4. Position the machine on a clear, leveled surface. DO NOT use the machine near water or outdoors.
5. Keep hands away from all moving parts.
6. Always wear appropriate workout clothing when exercising. DO NOT wear robes or other clothing that could become caught in the machine. Running or aerobic shoes are also required when using the machine.
7. Use the machine only for its intended use as described in this manual. DO NOT use attachments not recommended by the manufacturer.
8. Do not place any sharp object around the machine.
9. Disabled person should not use the machine without a qualified person or physician in attendance.
10. Before using the machine to exercise, always do stretching exercises to properly warm up.
11. Never operate the machine if the machine is not functioning properly.

WARNING: BEFORE BEGINNING ANY EXERCISE PROGRAM, CONSULT YOUR PHYSICIAN. THIS IS ESPECIALLY IMPORTANT FOR INDIVIDUALS OVER THE AGE OF 35 OR PERSONS WITH PRE-EXISTING HEALTH PROBLEMS. READ ALL INSTRUCTIONS BEFORE USING ANY FITNESS EQUIPMENT. IMPEX INC. ASSUMES NO RESPONSIBILITY FOR PERSONAL INJURY OR PROPERTY DAMAGE SUSTAINED BY OR THROUGH THE USE OF THIS PRODUCT.

SAVE THESE INSTRUCTIONS.

HARDWARE IDENTIFIER

PLACE WASHER, END OF BOLT, OR SCREW ON CIRCLE TO CHECK FOR CORRECT SIZE.

MILLIMETERS

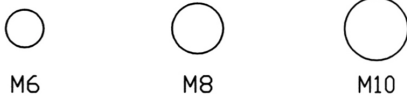

INCHES

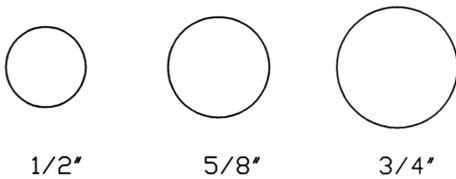

REPLACEMENT PARTS

Thank you for purchasing IMPEX product. Although we go to great effort to ensure the quality of our products, Occasionally errors or omissions occur. Should you find either a defective or missing part in this product, Please contact us for a replacement at the telephone number.

QUESTION ?



1-800-999-8899

NOTE: When installing a Aircraft Nut (also called Nylon or Lock Nut), Please use two adjustable wrenches to tighten down the Nut. Hold down the Bolt with one wrench, and use the other wrench to turn the Nut clockwise.

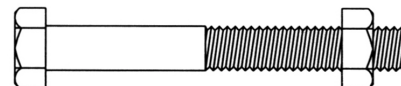
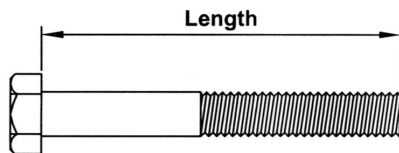

HEX HEAD BOLT

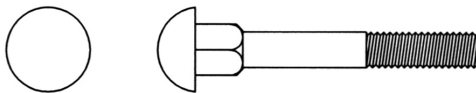

CARRIAGE BOLT

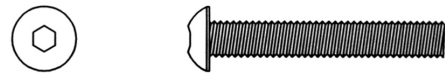

ALLEN BOLT



AIRCRAFT NUT



FLAT WASHER

ASSEMBLY INSTRUCTION

Tools Required Assembling the Machine: Adjustable Wrench and Allen Wrench

NOTE: It is strongly recommended this machine to be assembled by two or more people to avoid possible injury.

STEP 1 (See Diagram 1)

- A.) Attach the Rear Stabilizer (#33) and the Base Frame (#45) to the Main Stabilizer (#35). Secure them with two M12 x 4" Carriage Bolts (#38), \varnothing 1" Washers (#12) and M12 Aircraft Nuts (#13).
- B.) Attach the Rear Vertical Beam (#19) to the Rear Stabilizer (#33). Secure it with two M12 x 1" Allen Bolts (#29) and \varnothing 1" Washers (#12).
- C.) Attach the Front Vertical Beam (#22) to the Base Frame (#45). Secure it with two M12 x 4" Carriage Bolts (#38), \varnothing 1" Washers (#12), and M12 Aircrafts (#13).
- D.) Attach the Seat Frame (#53) to the Base Frame (#45). Secure it with three M12 x 1" Allen Bolts (#29) and \varnothing 1" Washers (#12).

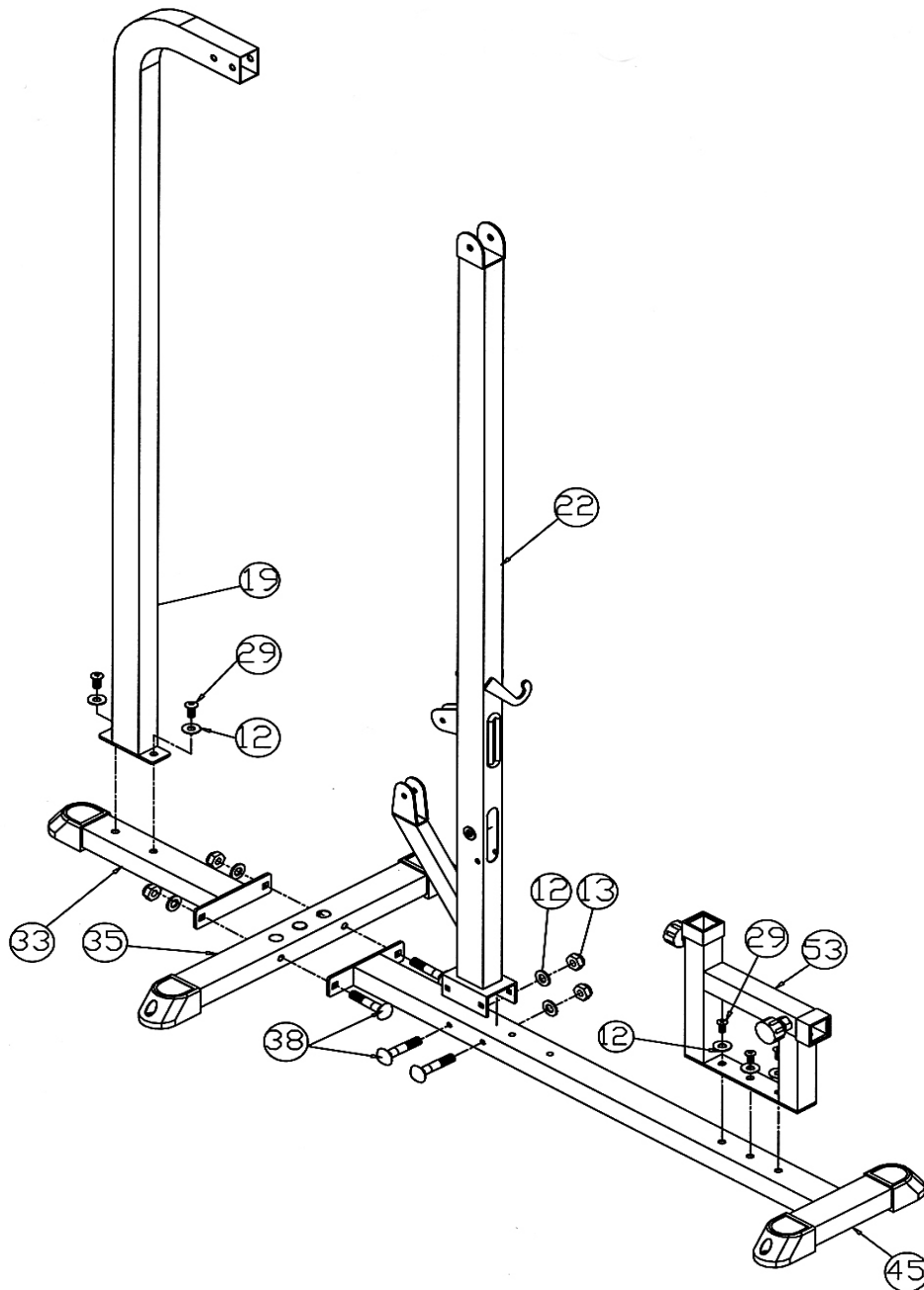

STEP 2 (See Diagram 2)

- A.) Align the rear of Upper Frame (#8) to the Rear Vertical Beam (#19). Attach the Top Socket Assembly (#14) to the joint. Secure it with four M12 x 3 1/8" Carriage Bolts (#11), \varnothing 1" Washers (#12), and M12 Aircraft Nuts (#13). Do not tighten the bolts yet.
- B.) Place the Upper Frame onto the open bracket on the Front Vertical Beam (#22). Secure it with one M10 x 3" Allen Bolt (#44), two \varnothing 3/4" Washers (#43), and one M10 Aircraft Nut (#5). Securely tighten all bolts previously installed.
- C.) Attach the Foot Plate Support (#40) to the Base Frame (#45). Secure it with two M12 x 1" Allen Bolts (#29) and \varnothing 1" Washers (#12).
- D.) Attach the Foot Plate (#41) to the Foot Plate Support (#40). Secure it four M10 x 1" Allen Bolts (#42), \varnothing 3/4" Washers (#43), and M10 Aircraft Nuts (#5).

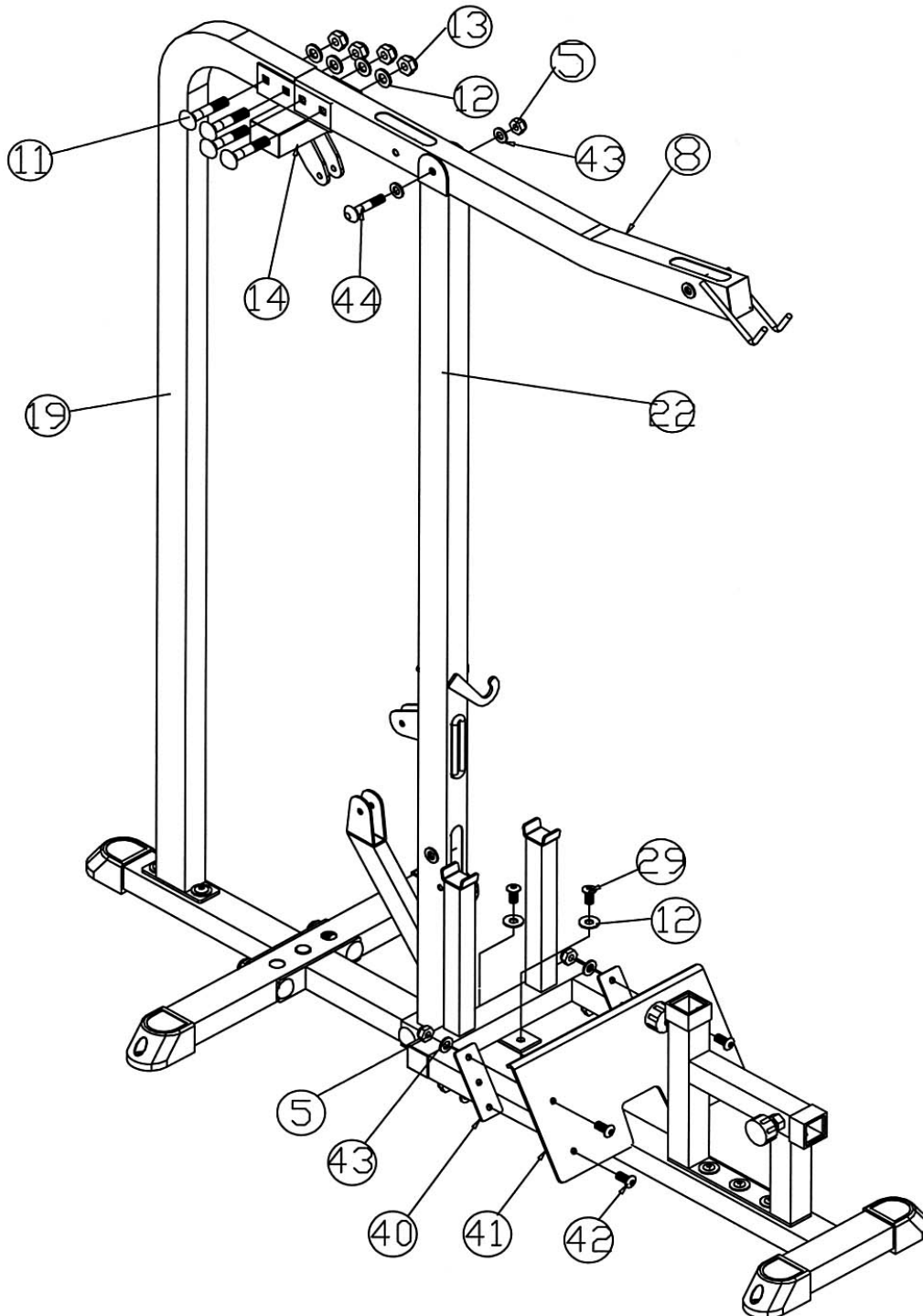

STEP 3 (See Diagram 3)

- A.) Insert the two Guide Rods (#18) into the holes on the Main Stabilizer (#35). Slide two Rubber Washers (#26) onto the Guide Rods from the top. NOTE: WD-40 or similar lubricant might be needed to reduce friction.
- B.) Slide two Guide Rod Sleeves (#28) and two Rubber Bumpers (#27) onto the Guide Rods (#18). Then slide the Weight Holder (#24) onto the two Guide Rods. At last, slide two Guide Rod Rings (#15) onto the Guide Rods.
- C.) Align the Guide Rods to the holes on the Top Socket Assembly (#14). Lift up the Rings (#15) to secure the Rods with two M8 x ½" Allen Bolts (#16).
- D.) Slide a Rubber Washer (#26) and Olympic Sleeve (#30) onto the post on the Weight Holder (#24). Secure the Olympic Sleeve with a M8 x ½" Allen Bolt (#16). Plug an Olympic Sleeve End Cap (#34) to the end. Clip a Spring Clip (#32) onto the Sleeve. Repeat the same procedure for the other side.
- E.) Attach the Arm Curl Pad (#55) to the Arm Curl Stand (#54). Secure it with two M8 x 1 3/8" Allen Bolts (#49) and Ø 5/8" Washers (#50). Insert the Stand into the top opening on the Seat Frame (#53). Use the Lock Knob (#46) to select desired height for the Arm Curl Pad.
- F.) Insert the Seat Adjustment Frame (#47) into the front opening on the Seat Frame (#53). Use a Lock Knob (#46) to select the desired position.
- G.) Attach the Seat Pad (#51) to the Seat Post (#52). Secure it with two M8 x 1 3/8" Allen Bolts (#49) and Ø 5/8" Washers (#50). Insert the Seat Post into the Seat Adjustment Frame (#47). Use the Lock Knob to select desired height for the Seat.

DIAGRAM 3

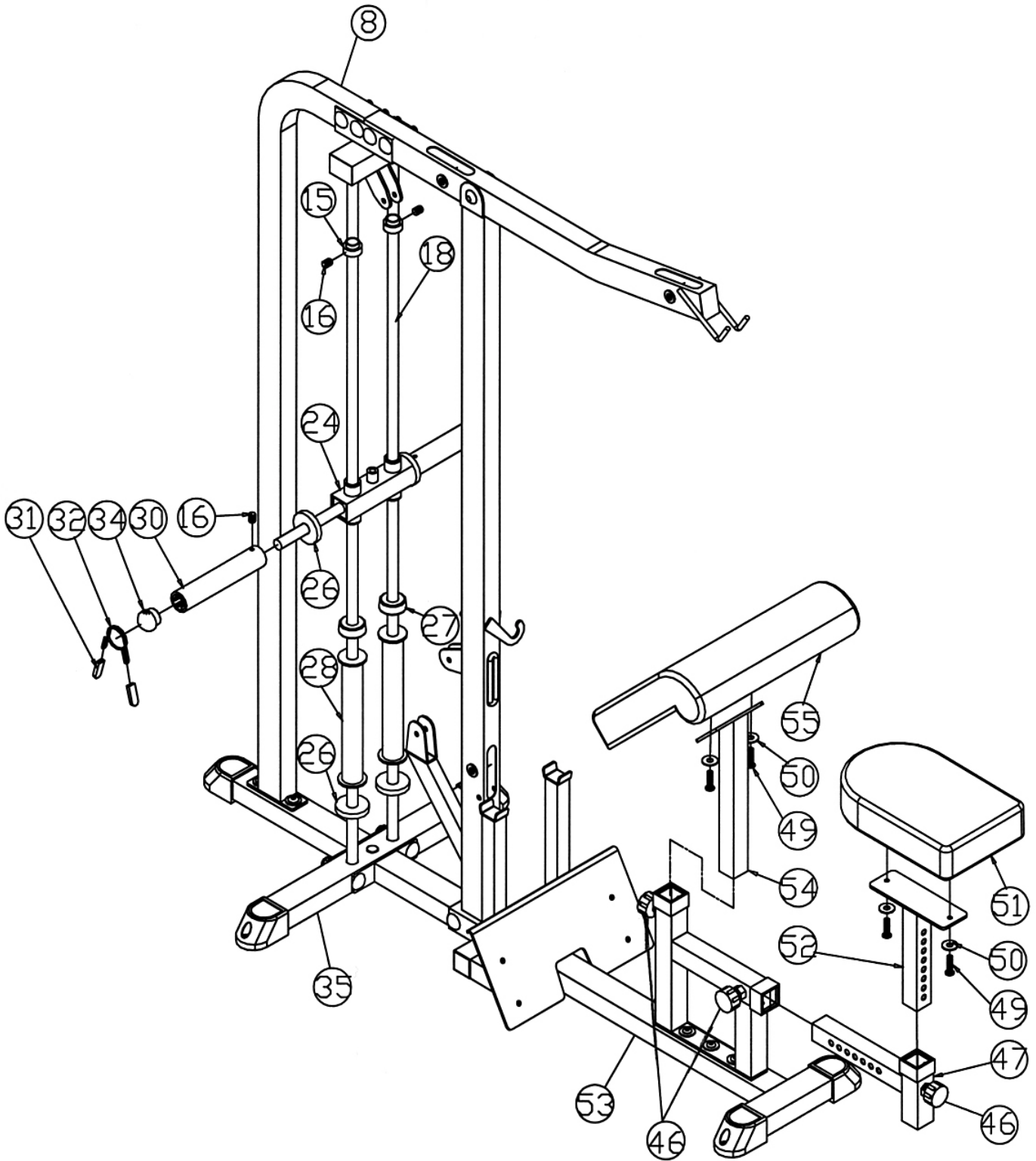

STEP 4 (See Cable Loop & Diagram 4)

- A.) Attach the 119" Upper Cable (#10) to the front opening on the Upper Frame (#8). Make sure the ball stopper on the Cable is under the opening.
- B.) Attach a Pulley (#9) to the opening. Secure it with one M10 x 2 ½" Allen Bolt (#7), two Bushings (#6), and one M10 Aircraft Nut (#5).
- C.) Draw the Cable towards the back of the machine to the second opening on the Upper Frame. Repeat Step B above to install a Pulley.
- D.) Draw the Cable downward. Place a Pulley in between the two Pulley Brackets (#21). Secure them together with one M10 x 2" Allen Bolt (#17), two Ø ¾" Washers (#43), and one M10 Aircraft Nut (#5). Draw the Cable around the Pulley and the Bracket hanging for now.
- E.) Pull the Cable upward towards the open bracket on the Top Socket Assembly and install a Pulley to the bracket.
- F.) Pull the Cable downward to the opening hole on top of the Weight Holder. Thread the tip of the Cable into the hole to firmly secure the Cable.
- G.) Attach the 104" Lower Cable (#23) to the upper opening on the Front Vertical Beam (#22) and install a Pulley. Make sure the ball stopper is in the front of the Beam. Draw the Cable underneath the Pulley then pull up to the hanging Pulley Bracket previously installed.
- H.) Install a Pulley to the lower opening on the hanging Bracket. Note: There are a few holes on the Bracket. Use these holes to adjust the tightness of the Cables by selecting different holes. Draw the Cable over the Pulley then downward to the open bracket on the Front Vertical Beam.
- I.) Install a Pulley to the open bracket. Pull the Cable underneath the Pulley toward the lower opening on the Front Vertical Beam. Repeat the Step B above to install a Pulley.
- J.) Insert a M10 x 2 3/8" Allen Bolt (#7) through the hole underneath the Pulley. Tighten it with two Ø ¾" Washers (#43) and one M10 Aircraft Nut (#5).
- K.) Attach a C-clip (#2) to the tip of the Cable end. Attach a Chain (#3) to the C-clip. Connect the Curl Bar (#56) to the Chain using another C-clip.
- L.) Repeat the Step K to install the Lat Bar (#1) and the Double D-bar Handle (#57).
- M.) Plug the 2" x 2 ¾" End Cap (#4) into the front opening on the Upper Frame (#8).

CABLE LOOP DIAGRAM

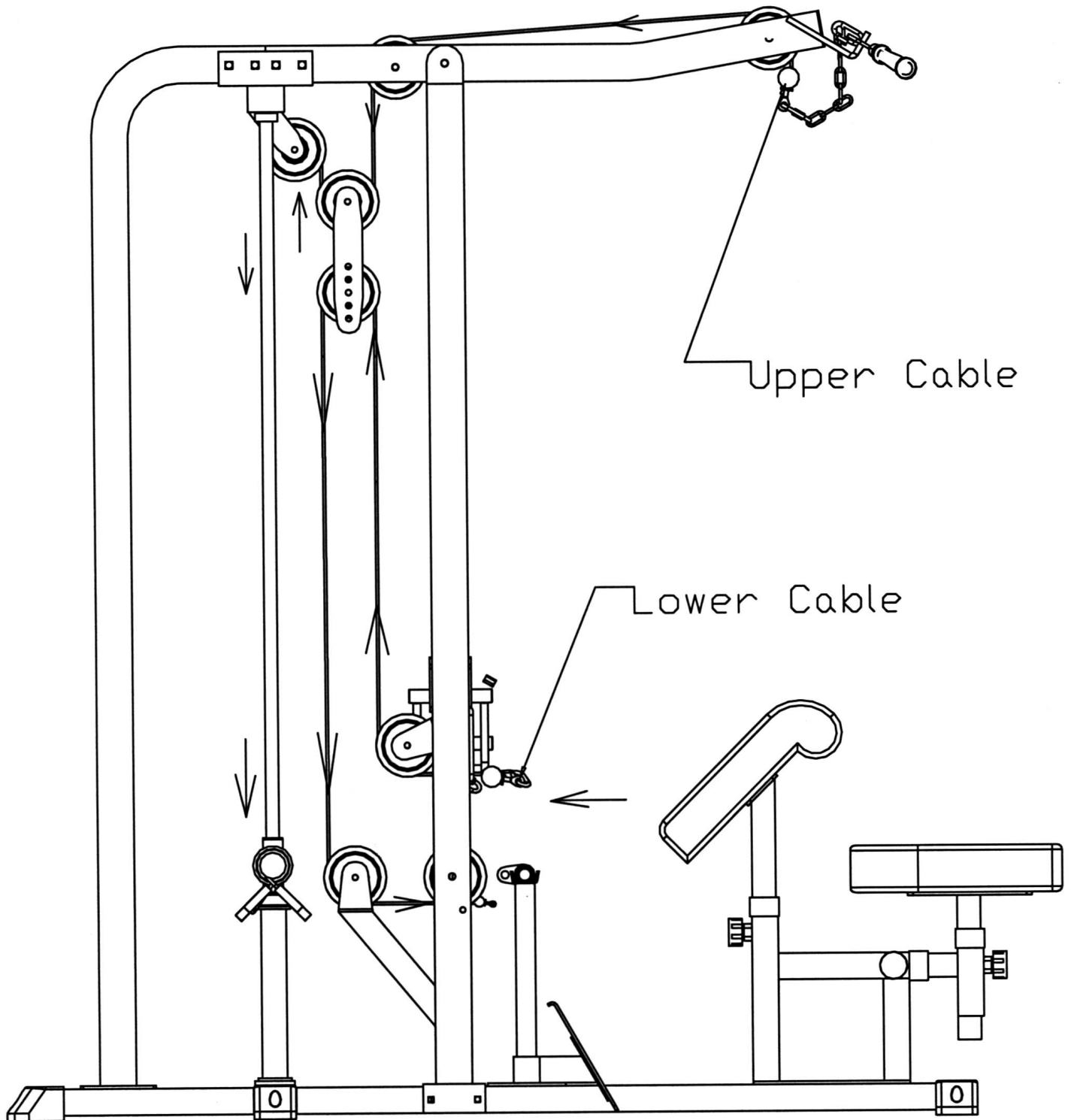
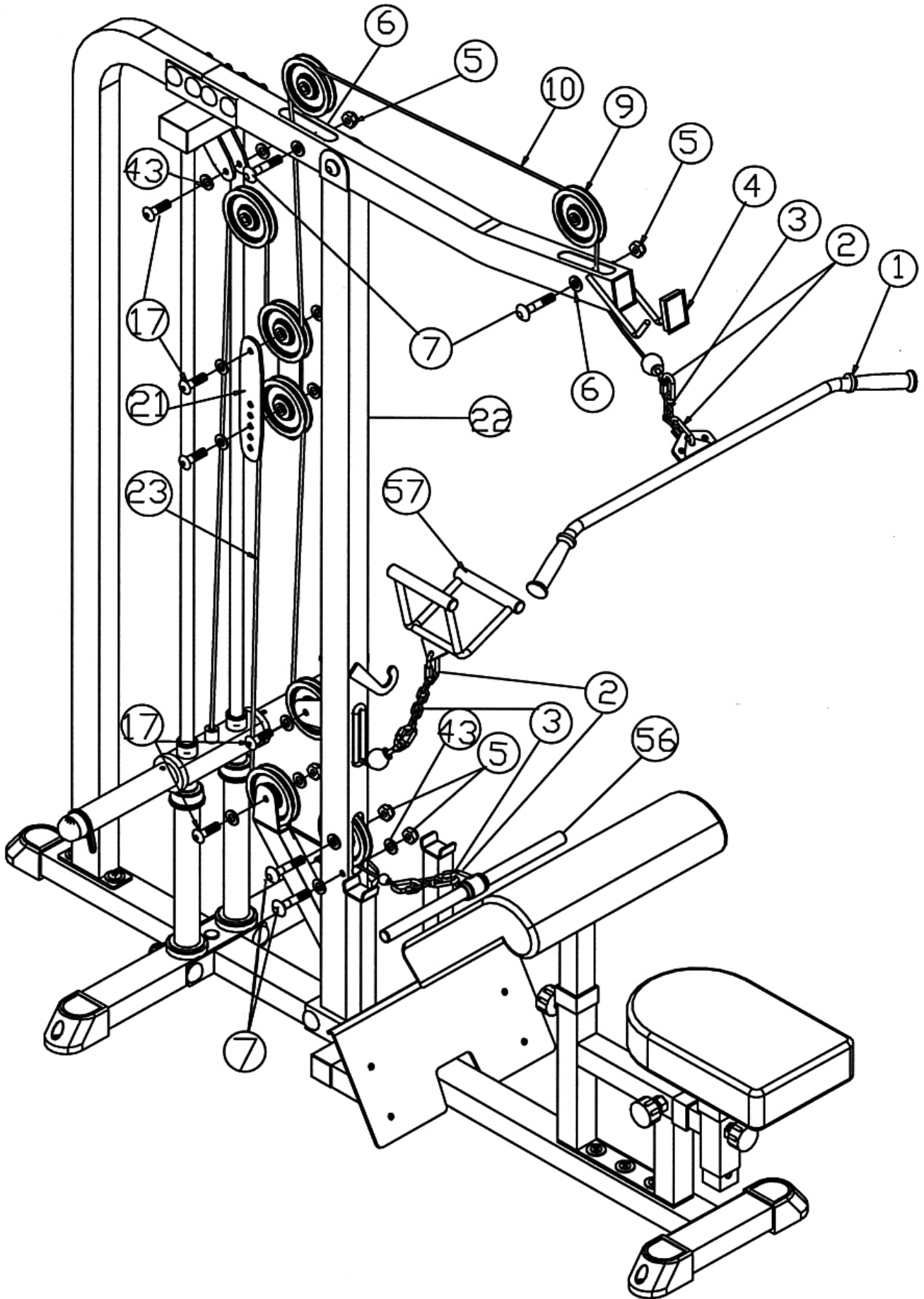
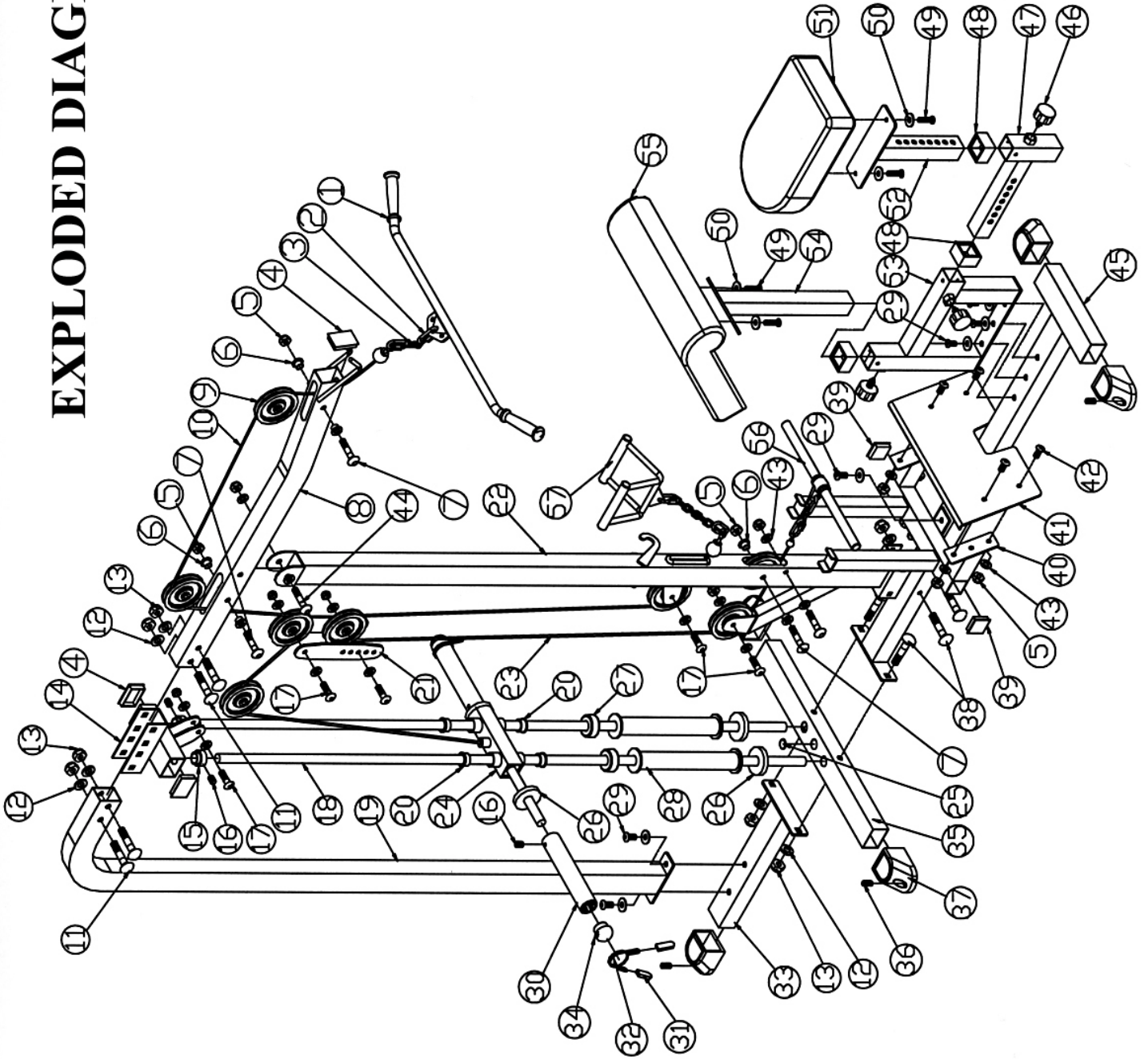

DIAGRAM 4



EXPLODED DIAGRAM



PARTS LIST

KEY NO.	DESCRIPTION	Q'ty
1	Lat Bar	1
2	C-clip	6
3	Chain	3
4	2" x 2 3/4" End Cap	3
5	M10 Aircraft Nut	14
6	Bushing	6
7	M10 x 2 1/2" Allen Bolt	4
8	Upper Frame	1
9	Pulley	8
10	119 " Upper Cable	1
11	M12 x 3 1/8" Carriage Bolt	4
12	Ø 1" Washer	15
13	M12 Aircraft Nut	8
14	Top socket Assembly	1
15	Guide Rod Ring	2
16	M8 x 1/2" Allen Bolt	4
17	M10 x 2" Allen Bolt	5
18	Guide Rod	2
19	Rear Vertical Beam	1
20	Plastic Bushing	4
21	Pulley Bracket	2
22	Front Vertical Beam	1
23	104" Lower Cable	1
24	Weight Holder	1
25	Ø1" End Cap	1
26	Rubber Washer	4
27	Rubber Bumper	2
28	Guide Rod Sleeve	2
29	M12 x 1" Allen Bolt	7
30	Olympic Sleeve	2
31	Spring Clip Sleeve	4
32	Spring Clip	2
33	Rear Stabilizer	1
34	Olympic Sleeve End Cap	2
35	Main Stabilizer	1
36	M10 x 1" Round Allen Bolt	5
37	Horse Shoe End Cap	5
38	M12 x 4" Carriage Bolt	4
39	2" Square End Cap	2
40	Foot Plate Support	1
41	Foot Plate	1
42	M10 x 1" Allen Bolt	4
43	Ø 3/4" Washer	18
44	M10 x 3" Allen Bolt	1
45	Base Frame	1
46	Lock Knob	3
47	Seat Adjustment Frame	1
48	Plastic Sleeve	3
49	M8 x 1 3/8" Allen Bolt	4
50	Ø 5/8" Washer	4
51	Seat Pad	1
52	Seat Post	1
53	Seat Frame	1
54	Arm Curl Stand	1
55	Arm Curl Pad	1
56	Curl Bar	1
57	Double D-bar Handle	1

IRON GRIP SPORT

By IMPEX FITNESS PRODUCTS

LIMITED LIFE TIME WARRANTY

IMPEX FITNESS PRODUCTS ("IMPEX") warrants this product to be free from defects in workmanship and material, under normal use and service conditions, for a period of LIFE TIME on the Frame and Weld, 3 YEARS on parts, and 6 MONTHS on upholstery from the date of purchase. This warranty extends only to the original purchaser. IMPEX's obligation under this Warranty is limited to replacing or repairing, at IMPEX's option.

All returns must be pre-authorized by IMPEX. Pre-authorization may be obtained by calling IMPEX Customer Service Department at 1-800-999-8899. All freights on products returned to IMPEX must be prepaid by the customer. This warranty does not extend to any product or damage to a product caused by or attributable to freight damage, abuse, misuse, improper or abnormal usage or repairs not provided by an IMPEX authorized service center or for products used for heavy commercial or rental purposes. No other warranty beyond that specifically set forth above is authorized by IMPEX.

IMPEX is not responsible or liable for indirect, special or consequential damages arising out of or in connection with the use or performance of the product or other damages with respect to any economic loss, loss of property, loss of revenues or profits, loss of enjoyments or use, costs of removal, installation or other consequential damages or whatsoever natures. Some states do not allow the exclusion or limitation of incidental or consequential damages. Accordingly, the above limitation may not apply to you.

The warranty extended hereunder is in lieu of any and all other warranties and any implied warranties of merchantability or fitness for a particular purpose is limited in its scope and duration to the terms set forth herein. Some states do not allow limitations on how long an implied warranty lasts. Accordingly, the above limitation may not apply to you.

This warranty gives you specific legal right. You may also have other rights which vary from state to state. Register on-line at www.impex-fitness.com

IMPEX INC.
14777 Don Julian
City of Industry, CA 91746

ORDERING REPLACEMENT PARTS

Replacement parts can be ordered by calling our Customer Service Department toll-free at **1-800-999-8899** during our regular business hours: Monday through Friday, 9 am until 5 pm Pacific standard time.
info@impex-fitness.com

When ordering replacement parts, always give the following information.

1. Model
2. Description of Parts
3. Part Number
4. Date of Purchase