

IPGSM-DPC **Commercial Fire Communicator** **Installation and Setup Guide**

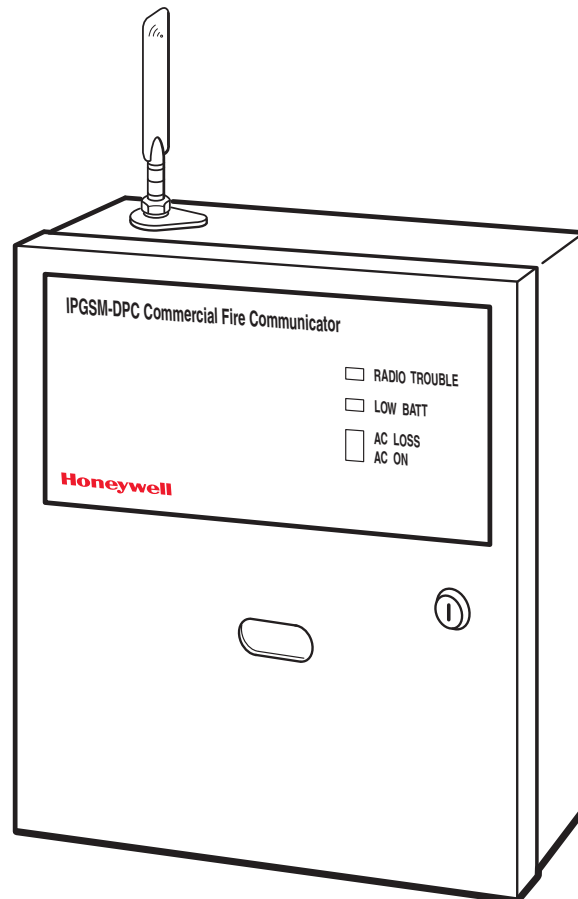

Contents

General Information	1
Package Contents	1
Compatible Fire Panels	1
Operation	2
Installation	3
ULC Compliance	3
STEP 1 – Setup the Customer Account.....	3
STEP 2 – Register the Communications Module with AlarmNet	3
STEP 3 – Determine the Signal Strength and Select a Location	4
STEP 4 – Mount and Wire	4
Wiring the 659EN Line Fault Monitor (if required)	7
STEP 5 – Program the Communications Module	8
STEP 6 – Configure the Fire Panel	9
STEP 7 – Test the System.....	9
Dialer Capture Module Information	10
LED Display Information	10
PowerBoost1 Module Information.....	11
iGSM Communications Module Information	12
RF Specifications	13
Central Station Messages.....	13
IPGSM-DPC Trouble Detection Information	14
IPGSM-DPC Specifications	14
Wiring Diagram.....	Inside of Back Cover

General Information

The IPGSM-DPC Commercial Fire Communicator (henceforth referred to as IPGSM-DPC) includes everything you need to upgrade a commercial fire system that previously reported by POTS to a system that uses the Internet as its primary reporting path, and uses a GSM cellular reporting path as a backup. In addition, this communicator utilizes a sophisticated power module (PowerBoost1) that monitors and reports AC power loss, low battery, and missing battery conditions.

Package Contents

- Red Fire Cabinet and Back Plate
- Cam Lock with Key
- Dialer Capture Module
- iGSM Communications Module
- 50 ohm cable assembly
- Antenna and Mounting Adapter
- PowerBoost1
- Battery harness/fuse (# 100-02415)
- Ferrite Filter
- LED Display board
- Mounting Rails (for above)
- Hardware Bag
- Transformer, 18VAC (# 1451-UL9)

Compatible Fire Panels

The IPGSM-DPC works with:

- All Fire Panels that are listed in the table below.
- All Fire Panels that use the Contact ID communication format as described in the SIA DC-05 Standard.

IMPORTANT: For a fire panel that has more than 9 active partitions, the first 9 partitions are reported to the central station uniquely. Beyond 9 partitions, only the 2nd digit of the partition is reported along with a leading zero (example partition 14 is reported as 04). **The installer must inform the central station of this condition.**

The IPGSM-DPC is compatible with the Honeywell brand FACP's listed below when the model 659EN Line Fault Monitor is installed.

Honeywell Fire Panel	Communicator
411	family two
411UD	family two
411UDAC	family two
FireWarden-100-2C	family three
FireWarden-100-2C-FR	family three
FireWarden-50C	family two
FireWarden-50C-FR	family two
MS-10UD-7C	family three
MS-10UD-7C-FR	family one (requires UDACT)
MS-25C	family four
MS-5UD-7C	family three
MS-5UD-7C-FR	family one (requires UDACT)
MS-9050UDC	family two
MS-9050UDC-FR	family two
MS-9200UDLSC	family three
MS-9200UDLSC-FR	family three
MS-9600LSC	family three Use the DACT-UD2 product to interface the IPGSM-DPC.

Honeywell Fire Panel	Communicator
MS-9600LSC-FR	family three Use the DACT-UD2 product to interface the IPGSM-DPC.
NFS2-3030	family one (requires UDACT)
NFS2-3030-FR	family one (requires UDACT)
NFS2-640	family one (requires UDACT)
NFS2-640-FR	family one (requires UDACT)
NFS-320	family one (requires UDACT)
NFS-320C	family one (requires UDACT)
NFS-320C-FR	family one (requires UDACT)
NFS-320SYS	family one (requires UDACT)
NFS-320SYS-FR	family one (requires UDACT)
NSP-25C	family four
SFP-10UDC	family three
SFP-10UDC-FR	family three
SFP-5UDC	family three
SFP-5UDC-FR	family three

Operation

The IPGSM-DPC replaces the fire panel's POTS communications path. When an event occurs, the fire panel goes off-hook to dial the central station. The IPGSM-DPC detects the off-hook condition and provides the fire panel with a dial tone. When the fire panel detects the dial tone, it begins dialing the central station. The IPGSM-DPC considers the three second period after dialing as the number dialing has been completed. After the dialing is completed, the Dialer Capture Module returns a handshake to the fire panel.

The fire panel then sends the contact ID reports to the IPGSM-DPC, which in turn sends a kiss-off after the report is successfully received from the fire panel. Within the IPGSM-DPC, the Dialer Capture Module sends the contact ID reports over the ECP bus to the iGSM Communications Module. When all the reports are sent, the fire panel goes on-hook. The IPGSM-DPC then transmits the messages to the central station (either over the internet or the GSM network).

Installation

ULC Compliance

To meet Canadian ULC compliance, ensure the following:

- IPGSM-DPC must be installed in accordance with Canadian Electrical Code, Part 1.
- IPGSM-DPC must be mounted in the same room and within 20 feet of the fire panel. The wiring must be routed through conduit.
- IPGSM-DPC, and all equipment used for the IP connection (such as the router, hub, modem, etc.) shall be listed, must be powered from an un-switched branch circuit, and be provided with appropriate standby power.
- IPGSM-DPC must use a 7AH battery (not supplied) to provide 24-hour backup capability.

STEP 1 – Setup the Customer Account

The communicator requires a subscriber account (customer account) to be setup with AlarmNet Direct. This is accomplished by registering the communicator's iGSM communications module with AlarmNet. Registering, enables the fire panel to send reports.

To setup the customer account you will need to contact the central monitoring station to get account information, and have access to the AlarmNet Direct website. To access the AlarmNet Direct website visit – **<https://services.alarmnet.com/AlarmNetDirect>**

If you do not wish to use the AlarmNet Direct website, you may call AlarmNet to setup the account, just phone 800-222-6525, then select option 1.
(Monday–Friday 8:00 am to 9:00 pm, Saturday 9:00 am to 5:30 pm EST)

Have the following information ready:

- Primary City ID (two digits), obtained from your monitoring station.
- Primary Central Station ID (two digits), obtained from your monitoring station.
- Primary Subscriber ID (four digits), obtained from your monitoring station.
- Communication Module's MAC ID, and MAC CRC number located on outside of box, and inside of the module.

<p>Note: The SIM supplied for the IPGSM-DPC is <u>already activated</u>. Therefore no SIM activation is necessary.</p>

STEP 2 – Register the Communications Module with AlarmNet

Registering the module activates the account with AlarmNet and enables the fire system's control panel to send reports. There are three methods that can be used to register the communications module.

- Register the module by logging into AlarmNet Direct and choosing “Show Programmed Devices GSM/I”. Search for the account using the Account Information or MAC ID. Under the “Actions” column, use the pulldown menu and choose Register. OR
- After the IPGSM-DPC is installed and programmed, you can register the module by clicking the Tamper Switch 3 times. OR
- After the IPGSM-DPC is installed and programmed, you can register the module using the 7720P Programming tool. Simply: Press [Shift] then press [↑]. Please wait for "Registration SUCCESS" message.

STEP 3 – Determine the Signal Strength and Select a Location

IMPORTANT - Do Not mount this device outdoors.

RF Exposure

Warning – The antenna(s) used for this transmitter must be installed to provide a separation distance of at least 20 cm from all persons and must not be collocated or operating in conjunction with any other antenna or transmitter.

When choosing a suitable mounting location, understand that signal strength is very important for proper operation. For most installations using the supplied antenna, mounting the unit as high as practical, and avoiding large metal components provides adequate signal strength for proper operation.

In this procedure, you will use the iGSM Communications Module to determine signal strength in order to find a suitable mounting location.

Note: Since the SIM is already activated, the RSSI signal strength indicators will indicate signal strength.

1. You will need a fully charged 12V battery.
2. Attach the Antenna (see illustration on page 6).
3. Temporarily wire the battery's negative [-] terminal to TB1-4 on the iGSM communications module, then wire the battery's plus [+] terminal to TB1-2 on the communications module. Wait about one minute for the module to initialize.
4. Position the assembly near a suitable mounting position and observe the RSSI display.
5. Look for a mounting position that yields at least 3 bars lit solid. Four or five bars are better.
6. Verify the signal strength remains steady for a few minutes, then mark that mounting position. Disconnect the battery.

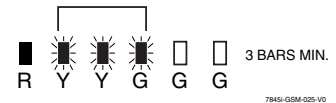

STEP 4 – Mount and Wire

- For ULC compliant installations, refer to the topic on *ULC Compliance* in this manual.
- For Dry/Indoor use only.
- External cabinet wiring **MUST** be routed in conduit.

This communicator comes partially assembled with all the components mounted except the Antenna, LED Display board, and PowerBoost1. To protect certain components on the PowerBoost1, it is shipped unmounted but fully wired.

Note: Refer to the diagram on page 6, and to the Wiring Diagram on the inside of the back cover of this manual for wiring and component identification.

1. Remove knockouts from cabinet to accommodate the power input wires, and wiring to the control panel. (DO NOT REMOVE the two knockouts directly above the PowerBoost1 module.) Then mount the cabinet securely to the wall using 4 screws or bolts. Use mounting screws or bolts that are suitable for the material being anchored to.
2. Ensure the cabinet door lock is installed.
3. Install the two plastic mounting rails for the LED Display board. They simply snap into the back plate holes.

4. Connect the LED Display board to its connector, then slide the board into the mounting rails. (Refer to the “*LED Display Information*” topic if a wire is detached from its connector.)
5. Carefully remove the packaging material that surrounds the PowerBoost1.
6. Mount the PowerBoost1 on the three unused standoffs. Use the **plastic screw** (prevents shorting) to secure the upper right corner of the PowerBoost1 and the two metal screws and lock washers to fasten the left side of the circuit board. Ensure the lock washers are located between the circuit board and the head of the two metal screws.
7. Use the 1451-UL9 Wired Transformer directly connected to un-switched facility power. Connect and route 14AWG (minimum) insulated wire from facility ground to the 1451-UL9 enclosure ground post and through the conduit to the IPGSM-DPC cabinet ground post.
8. Route 16AWG wire from the transformer secondary, through the conduit. Pass the wires through the Ferrite Filter, then loop the wires back through again making a loop. (Ensure the wire ends that connect to the PowerBoost1 Module are tinned.) Connect the wires to the PowerBoost1 AC terminals. **At this time DO NOT apply power.**

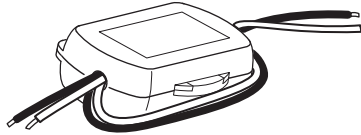

9. Ensure all ground connections are tight.
10. Connect the Ethernet cable and the Telco 1 and Telco 2 lines. If you choose to use an optional Cabinet Tamper Switch (if the control panel supports it) mount and wire it.
Note: The Ethernet cable, Telco 1, Telco 2 lines, and the optional cabinet Tamper Switch (if used) must be run through conduit.
11. Verify the PowerBoost1 module DIP switches are configured as shown below.

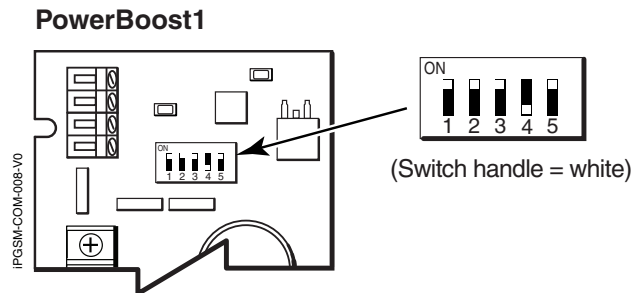

12. Ensure the following:
 - LED Display board is fully seated.
 - All wiring terminals and connectors are tight.
 - All wiring has been completed and secured with cable ties.
13. Install the battery (not supplied). Apply power to the 1451-UL9 Wired Transformer, and attach the battery cable.

IPGSM-DPC Commercial Fire Communicator – Installation and Setup Guide

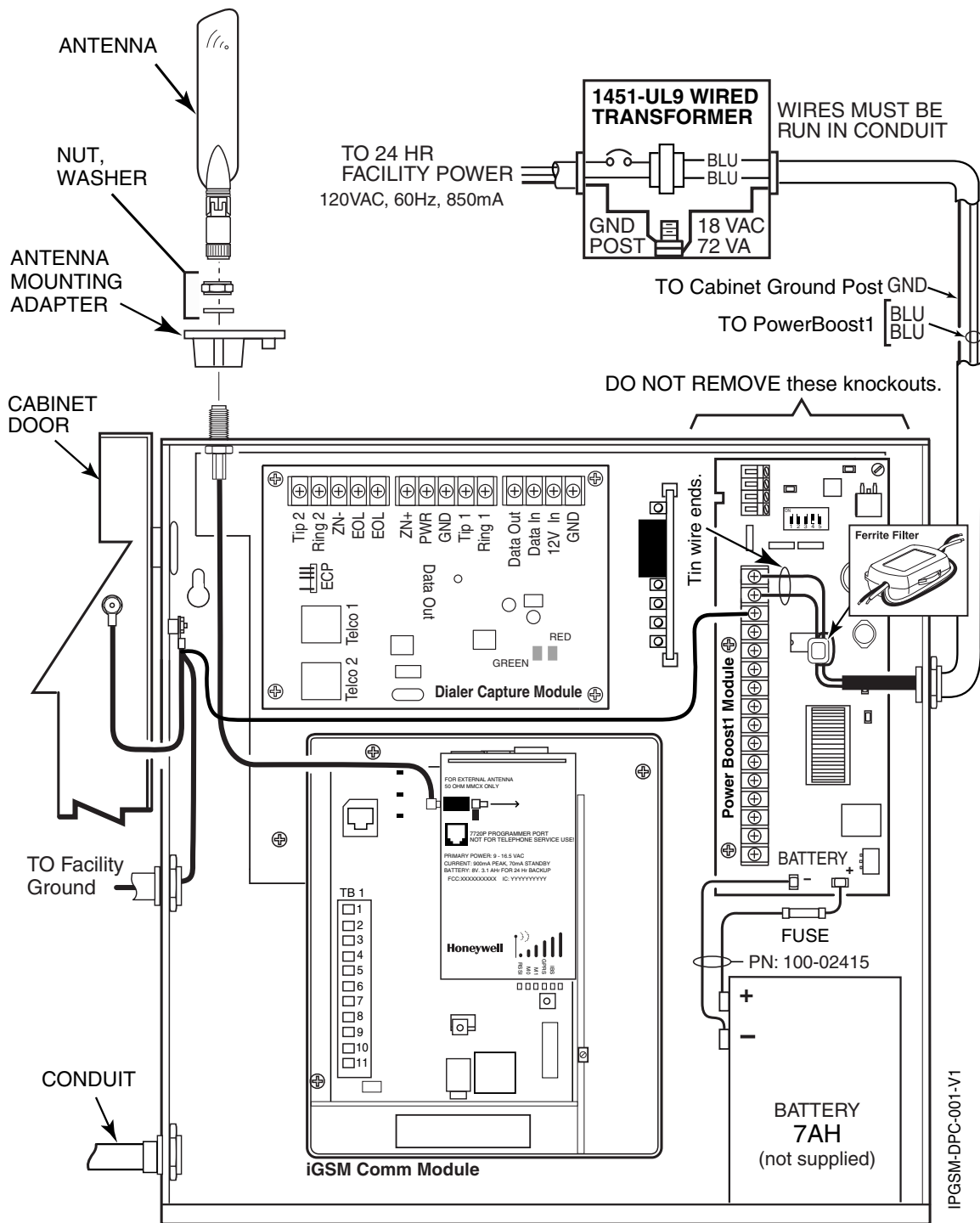

Wiring for Grounds, Power, and RF

Wiring the 659EN Line Fault Monitor (if required)

The IPGSM-DPC is compatible with the Honeywell brand FACP's listed on page 1 when the model 659EN Line Fault Monitor is installed.

1. Refer to the installation guide for the 659EN.
2. Mount the 659EN on the lower left side of the IPGSM-DPC cabinet.
3. **DO NOT** cut the 659EN's **BLACK Output Relay Jumper** or the **BLUE Voltage Trip Threshold Jumper**.
4. Complete the interface wiring as shown below:

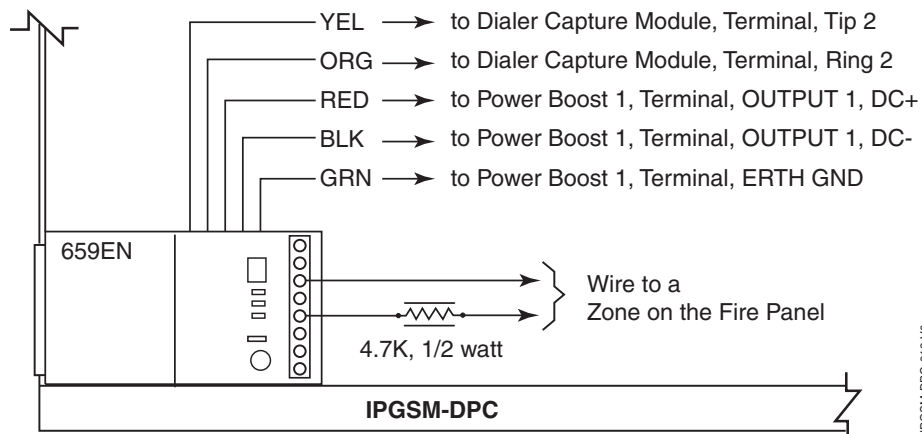

IPGSM-DPC-013-V0

Example wiring for an addressable fire control panel:

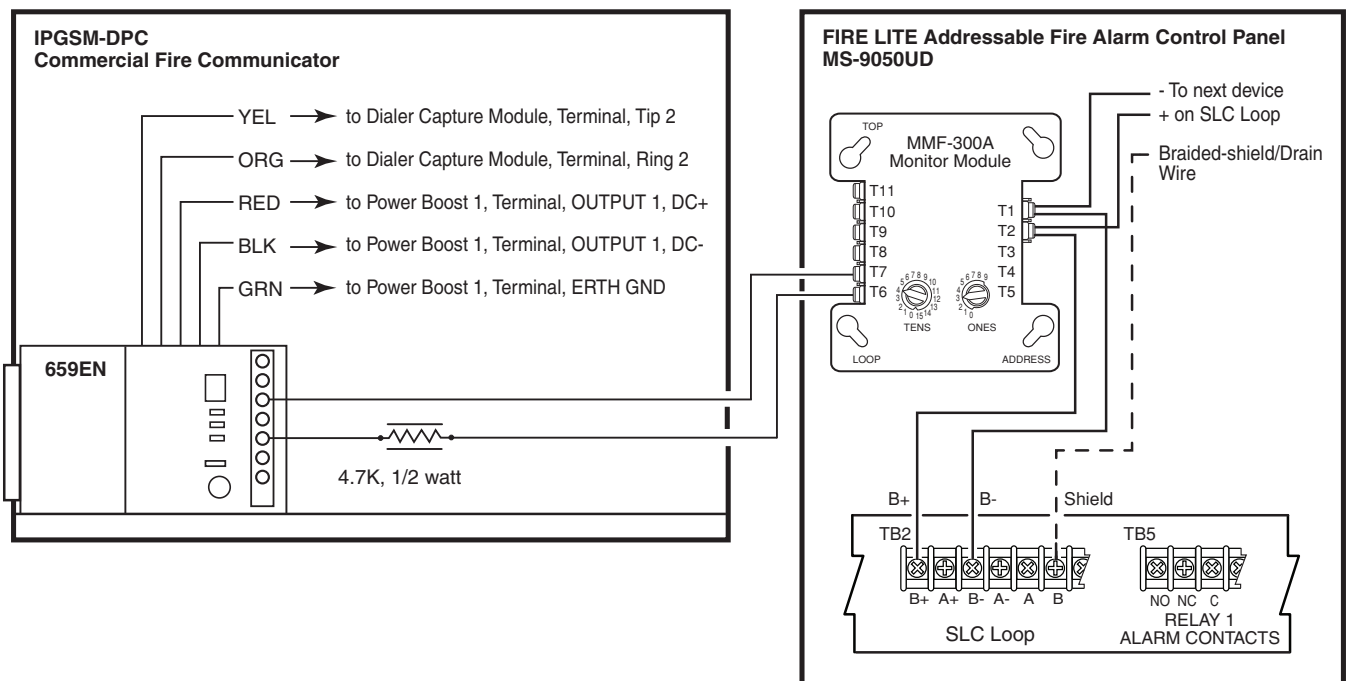

IPGSM-DPC-014-V0

STEP 5 – Program the Communications Module

You must use the 7720P Programming tool to program the IPGSM-DPC.

When using the 7720P Programming tool, the values given below are for most installations. Press the [#] key to accept the displayed default value (xxx) or enter the new value and press the [#] key for the next prompt. Use the [Space] key to scroll through a list of options.

1.	(no display)	Connect the 7720P.
2.	7720P PROGRAMMER	Press [#].
3.	Strt Prog Mode? Y/N	Press [Shift] then [Y], then [#].
4.	Program Device? Y/N	Press [Shift] then [Y], then [#].
5.	Com Path Choice (IP&GSM)	Press [Space] to scroll choices; IP&GSM, IP, or GSM. At choice, press [#].
6.	Primary City ID (??)	Enter number 01-99, then press [#].
7.	Primary CS ID (??)	Enter number 01-FE, then press [#].
8.	Primary Sub ID (????)	Enter number 0001-9999, then press [#].
		Note: If a Com Path Choice of IP&GSM or IP was selected, prompt 9 will appear.
9.	Use DHCP? Y/N (Y)	If your router is configured for DHCP, press [Shift] then [Y], then press [#].
		Note: If DHCP is not selected (your router is set for a static IP), prompts 10 through 13 will appear.
10.	NIC IP Address: 255.255.255.255	Enter choice, then press [#]. Follow the prompts.
11.	Subnet Mask: 255.255.255.255	Enter choice, then press [#]. Follow the prompts.
12.	Gateway IP Address: 255.255.255.255	Enter choice, then press [#]. Follow the prompts.
13.	DNS Serv IP Addr: 255.255.255.255	Enter choice, then press [#]. Follow the prompts.
14.	Review? Y/N	Enter choice, then press [#]. Follow the prompts.
15.	Create Password? Y/N	Enter choice, then press [#]. Follow the prompts.
16.	Exit Prog Mode? Y/N	Press [Shift] then [Y], then press [#].
17.	DONE	

- Notes:**
- If an error in programming occurs, set the factory defaults (see next topic) and reprogram.
 - The IP Fault Time, and the GSM Fault Time are each fixed at 1 minute and are not programmable.

To exit the programming mode, press [N] in response to the "Review?" prompt. Then press [Y] to the "Exit Prog Mode?" prompt. Upon exiting, the root file is updated to log the changes made. A message is displayed telling the user that this step is being executed. When complete, the message "DONE" is displayed to indicate the file was successfully uploaded.

Note: If critical configuration changes were made, such as the mode of operation, the communications module will reset to ensure that the programming features are enabled.

If the file is not successfully uploaded, one of the following prompts will be displayed. Follow the steps shown below until the upload is successful.

Display	Description	What to do
Cannot Upload Try Again? Y/N_	Module is not yet initialized.	Wait for RSSI indicator LEDs to be lit. Press [Y].
Failed to Update Root File!	Network problem, or you answered "N" to "Cannot Upload Try Again?" prompt.	Initiate the Force Server Update Command by pressing the [0] key.

Setting Factory Defaults

To reset the programming options to factory-default values, at the "Exit Prog Mode?" prompt press [Shift] plus [ESC]. Note, setting the factory defaults will also erase any password that may have been entered.

Set Default? Y/N_	Press [Y] to reset factory default values. Press [N] to cancel this function.
----------------------	----------------------------------------------------------------------------------

Press [Shift] then [Y], then [#]. The Create Password prompt appears, follow the prompts then exit.

STEP 6 – Configure the Fire Panel

1. Ensure the Telco Fault on the panel is enabled. Then choose a setting that is no higher than 90 seconds (or as close to that as the panel allows).
2. Ensure no more than 1 pause character (usually a comma) is programmed into the dialing string (usually 2 seconds). Note, this is necessary since the Dialer Capture Module waits only 3 seconds after the phone number is dialed. Having more than 3 seconds of pause time will cause it to think the phone number is complete and cause it to generate the high-low tones at an incorrect moment.

STEP 7 – Test the System

1. Close and lock the cabinet cover.
2. Refer to the fire panel's installation/operation guide for the testing procedure.
3. (Notify the monitoring station that a test will be conducted.) Test the system to ensure it is operating.
4. Verify communications with the central station is successful by sending several events. Also, get confirmation that these events were received.

Dialer Capture Module Information

LED Indicator	STATUS
RED – Steady ON	Messages exist in buffer.
RED – Flashing	No messages to be sent. Waiting for messages.
GREEN – Steady ON	Normal Indication.
GREEN – Blinks every 2 sec.	PowerBoost1 communication problem.
GREEN – Blinks twice every sec.	Communication Module connection is lost.
GREEN – Blinks 10 times every sec.	PowerBoost1 and Communications Module connection is lost.

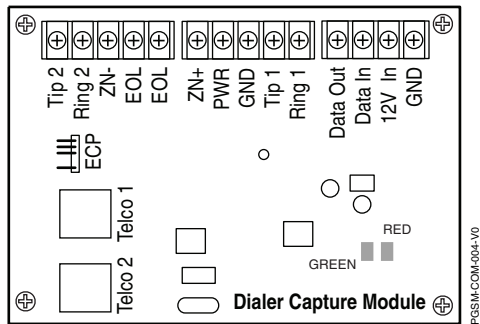

Note: Telco ports 1 (primary dialer) and 2 (secondary dialer) may be used instead of the terminal board.

Whichever connection method is used, both Telco paths must be connected to the Fire Panel.

LED Display Information

Panel Status	LED Indicator
RADIO TROUBLE	Yellow – ON when radio trouble is present. <ul style="list-style-type: none"> Both IP and GSM communication paths are lost. Communicator radio is not registered. Old Alarm Time has been exceeded. (Message has not been delivered within the fixed 10 minute window.)
	Buzzer – Upon loss of AC power, this will beep once every 10 seconds.
LOW BATTERY	Yellow – ON when battery is low (<11.5VDC).
	Yellow – (not used)
AC LOSS	Yellow – ON when no AC is present (< 90VAC).
AC ON	Green – ON when AC is present.

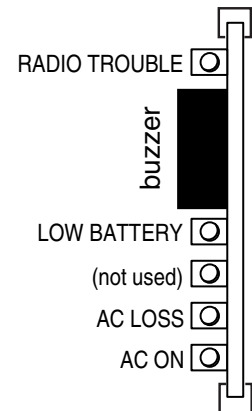

Note: If a wire pulled out of the LED Board Connector refer to the diagram on right and reinsert wire, ensuring the connector pin is locked in.

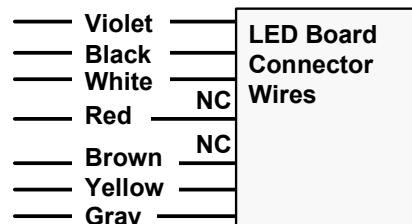

PowerBoost1 Module Information

LED Indicator	STATUS
AC (green)	AC power available.
ACTIVE (green)	Cyclical flashing – normal communications. Repetition of 3 flashes – loss of communications.
LOW BATT (yellow)	Missing or low battery.
TROUBLE (yellow)	One or more trouble conditions exist, such as; overload, output supervision, ground fault, or charger failure.

Notes:

- If AC power is lost and the battery voltage falls below 10v, the module's output voltage will be turned off. The output power is turned back on when AC power is restored.
- You must use the DIP switch settings shown below.

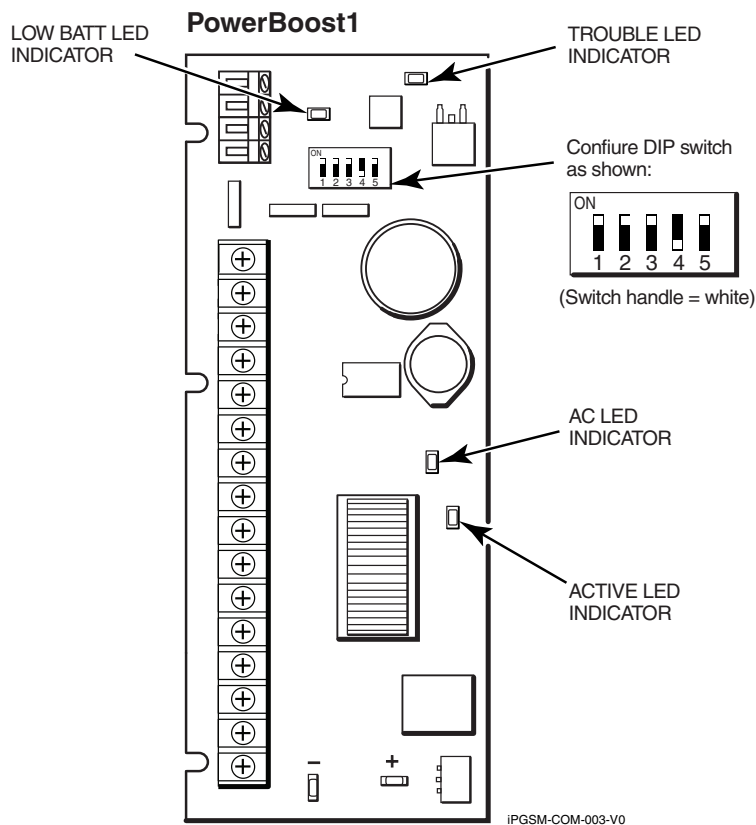

iGSM Communications Module Information

ON – NOT registered with AlarmNet. OFF – Registered with AlarmNet. FAST BLINK – Download session with Compass in progress. SLOW BLINK – In unison with yellow LED, registration in progress.	GRN				
ON – Message transmission pending. QUICK PERIODIC BLINK – Normal. FAST BLINK – Message waiting for network ACK. SLOW BLINK – Idle power abnormal. SLOW BLINK – In unison with green LED, registration in progress.	YEL				
ON – No contact with network. OFF – Normal. SLOW BLINK – Loss of communication with the Dialer Capture Module (ECP fault). FAST BLINK – No network contact AND loss of communication with the Dialer Capture Module.	RED				

Note: If all LEDs FAST BLINK in unison with the RSSI LEDs this indicates a Hardware Error.

ON – 100 MB/S link to Internet. OFF – 10 MB/S link to Internet.	Link Speed				
ON – Ethernet Link detected. OFF – No link detected. FAST BLINK – Transmitting/Receiving Data.	Ethernet Link/Activity	GREEN			

MODULE'S RECEIVED SIGNAL STRENGTH (RSSI)

When the **Mode Switch** is NOT depressed, LED 1 will illuminate red.

- The remaining LEDs indicate RSSI (Received Signal Strength).

MODULE'S OPERATION MODE

When the **Mode Switch** IS depressed, LED 1 will be OFF.

- LEDs 2 and 3 indicate the module's communication mode with the Dialer Capture Module.

Mode	LED 2 (yellow)	LED 3 (yellow)
ECP	OFF	OFF
Zone (NOT USED)	ON	OFF
4204 (NOT USED)	OFF	ON
2 - 4204 (NOT USED)	ON	ON

MODULE'S STATUS

When the **Mode Switch** IS depressed, LED 1 will be OFF.

- LEDs 4, 5, and 6 indicate the module's Status.

LED 4 (green)	LED 5 (green)	LED 6 (green)
ON - Connected to Internet. OFF - Not connected to Internet.	ON - GPRS service available. OFF - No GPRS service available FAST BLINK - GPRS in use.	ON - Module registered, no second site available. OFF - Module not registered with network carrier. SLOW BLINK - Module registered, second site available, and low signal strength. NORMAL BLINK - Module registered, second site available, acceptable signal strength. FAST BLINK - Module registered, second site available, excellent signal strength.

IPGSM-DPC-012-V0

RF Specifications

Band	Transmission Frequency (MHz)	Transmit Power (dBm)	Receive Frequency (MHz)	Receive Sensitivity (dBm)	Number of Channels	Channel Spacing (MHz)	Duplex Separation (kHz)
GSM 850	824-849	33	869-894	-107	124	200	45
GSM 900	890-915	33	935-960	-107	124	200	45
GSM 1800	1710-1785	30	1805-1880	-106	374	200	95
GSM 1900	1850-1910	30	1930-1990	-105.5	299	200	80

Central Station Messages

Alarm Condition	Alarm Code	Restore Code
Power On / Reset	E339 C0803	N/A
Power Loss	E337 C0803	R337 C0803
Low Battery	E338 C0803	R338 C0803
Battery Charger Failure	E314 C0803	R314 C0803
ECP Supervision (Compromise Indication)	E355 C0000	R355 C0000
Primary Communication Path Supervision	E350 C0951	R350 C0951
Secondary Communication Path Supervision	E350 C0952	R350 C0952
Periodic Comm Test Fail	E358 C0803	R358 C0803
Test	5555 5555 9	N/A
Specific to RESIDENTIAL / COMMERCIAL Control Panels (Such as the VISTA-10P, 15P, and 20P series.)		
UL: The information provided in this section for the VISTA-10P, 15P, and 20P series control panels has not been evaluated with this communications module.		
Communicator Trouble (low battery, ECP bus, network) (Possible Compromise Indication)	E353 C0803	R353 C0803
Radio Fault	E353 C0103	R353 C0103
Specific to COMMERCIAL Control Panels (Such as the VISTA-128/250 series.)		
Communicator Trouble (low battery, ECP bus, network) (Possible Compromise Indication)	E333 C0803	R333 C0803
Radio Loss of Signal (Possible Compromise Indication)	E357 C0803	R357 C0803 or R380 C0803
Radio Fault (low battery, tamper, ECP Bus)	E333 C0803	R333 C0803
AlarmNet Messages		
Communication failure. (Possible Compromise Indication)	5555 1555 6	5555 3555 6
Authorized Radio Substitution	00D0 010C 0	N/A
Unauthorized Radio Substitution Attempt	00D0 010E 0	N/A
Service Termination	00D0 020E 0	N/A

IPGSM-DPC Trouble Detection Information

Telco 1 is used for the Fire Panel to output contact ID messages to the IPGSM-DPC, and Telco 2 is used by the IPGSM-DPC to report faults to the Fire Panel. If Telco 1 is not operational, the Fire Panel will use Telco 2 to report events if there are no faults in the iGSM Communications module.

Fault Condition	Indication to Fire Panel
PowerBoost1 fault	Telco 2 is cut.
iGSM Communications Module fault <ul style="list-style-type: none"> Failure of the communications path when <u>IP only</u> or <u>GSM only</u> is programmed as a communications path. Failure of both communications paths when <u>IP&GSM</u> is programmed as a communications path. 	Telco 2 is cut. Telco 1 and 2 are cut.
Dialer Capture Module buffer is full.	Hang up. (Panel will retry, giving the buffer a chance to empty.)

IPGSM-DPC Specifications

ITEM	SPECIFICATION
Cabinet Dimensions:	Width = 12 3/4 inches Height = 14 7/8 inches Depth = 3 inches
Transformer: 1451-UL9	Primary – 120VAC, 60Hz, 850mA Secondary – 18VAC, 72VA
Battery:	12V, 7Ah sealed lead acid type (not supplied) Use a Honeywell 712BNP, Yuasa NP7-12 or equivalent.
Battery Charging Current:	maximum 1A
Supervision:	The Radio (communicator), battery, and AC power, conditions are monitored by the cabinet indicator LEDs: RADIO TROUBLE lights when any of these conditions exist. <ul style="list-style-type: none"> Both IP and GSM communication paths are lost. Communicator radio is not registered. Old Alarm Time has been exceeded. (Message has not been delivered within the fixed 10 minute window.) LOW BATTERY lights when the battery voltage is less than 11.5VDC. AC LOSS lights when the AC power is less than 90VAC.

NOTES

NOTES

NOTES

NOTES

NOTES

NOTES

Wiring Diagram

The wiring diagram below is depicted for point-to-point electrical connection checks used for troubleshooting or component replacement. It is not intended to show the physical routing of wires. When replacing a wire or component, ensure the wire is routed in the same manner as the original factory wire.

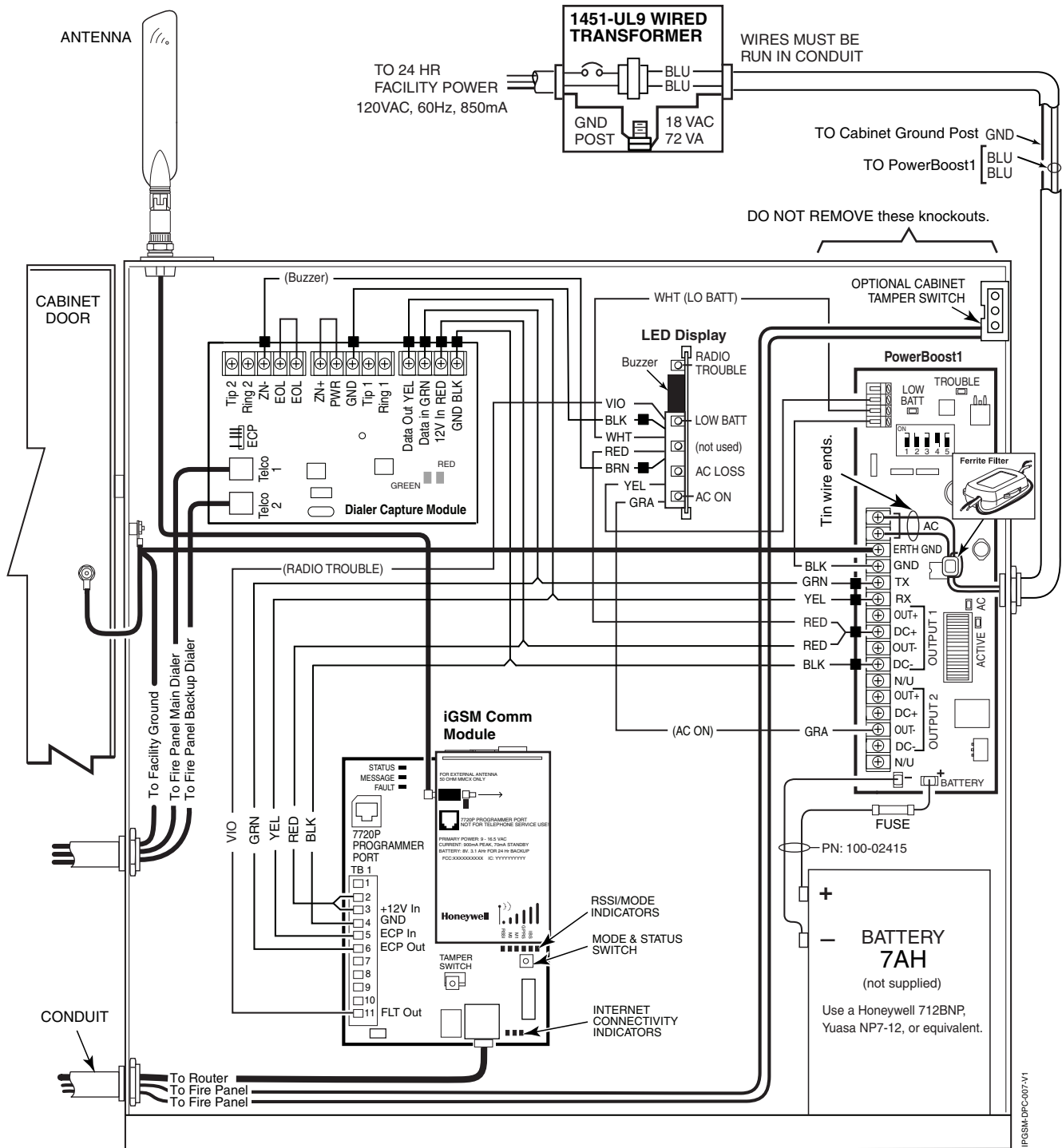

- NOTES**
- All circuits are power limited except the backup battery which is non-power limited.
 - Non-power limited wiring must be separated from the power limited wiring by at least 1/4 inch.
 - If desired, use a Honeywell 955WH Tamper Switch with the 28-2 bracket.

IC STATEMENT

Notice: This Class A digital apparatus complies with Canadian ICES-003.

Cet appareil numérique de la classe A est conforme à la norme NMB-003 du Canada.

IC STATEMENT

This device complies with RSS 210 of IC. Operation is subject to the following two conditions: (1) This device may not cause harmful interference. (2) This device must accept any interference received, including interference that may cause undesired operation.

Cet appareil est conforme à la RSS 210 des Industries Canada. Son fonctionnement est soumis aux conditions suivantes: (1) Cet appareil ne doit pas causer d'interférences nuisibles. (2) Cet appareil doit accepter toute interférence reçue y compris les interférences causant une réception indésirable.

DOCUMENTATION AND ONLINE SUPPORT

For the latest documentation and online support information, please go to:

<http://www.security.honeywell.com/hsc/resources/MyWebTech/>

WARRANTY

For the latest warranty information, please go to:

<http://www.security.honeywell.com/hsc/resources/wa/>

Honeywell

**2 Corporate Center Drive, Suite 100,
P.O. Box 9040, Melville, NY 11747**

Copyright © 2011 Honeywell International Inc.

www.honeywell.com/security

