

HONDA

Power

Equipment

Owner's Manual

TILLER

FR500/FR700

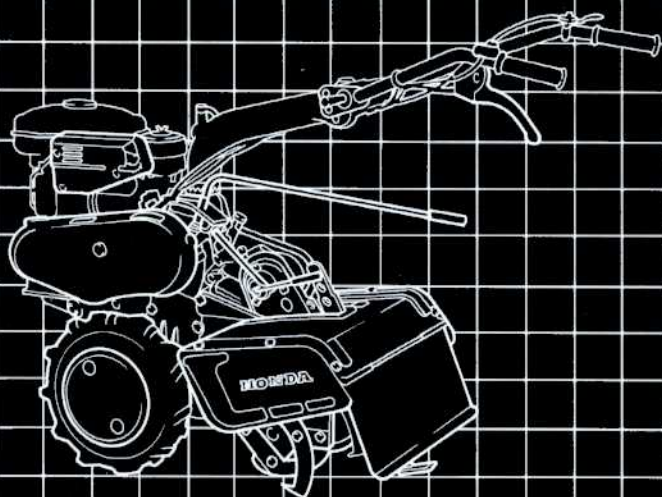

Thank you for purchasing a Honda tiller.

This manual covers operation and maintenance of FR500 and FR700 tillers. All information in this publication is based on the latest product information available at the time of approval for printing. The illustrations in this manual are based on the FR500 tiller.

Honda Motor Co., Ltd. reserves the right to make changes at any time without notice and without incurring any obligation.

No part of this publication may be reproduced without written permission.

This manual is considered a permanent part of the tiller and it must stay with the tiller if resold.

READ THIS OWNER'S MANUAL CAREFULLY. Pay special attention to these symbols and any instructions that follow:

▲ DANGER

— Indicates serious injury or death **WILL** result if instructions are not followed.

▲ WARNING

— Indicates a strong possibility that serious injury or death could result if instructions are not followed.

▲ CAUTION

— Indicates a possibility that minor injury can result if instructions are not followed.

IMPORTANT NOTICE

— Indicates that equipment or property damage can result if instructions are not followed.

NOTE: Gives helpful information.

Honda tillers are designed to give safe and dependable service if operated according to instructions. Operating this tiller requires special effort on your part to ensure your safety and the safety of others.

▲ WARNING

Using this product for a purpose not intended may cause injury or property damage. Read and understand this Owner's Manual before operating the tiller.

If a problem should arise, or if you have any questions about your tiller, consult an authorized Honda tiller dealer.

HONDA MOTOR CO., LTD. 1989, ALL RIGHTS RESERVED

CONTENTS

1. SAFETY INFORMATION	3
2. COMPONENT IDENTIFICATION	7
3. PRE-OPERATION CHECK	8
4. STARTING THE ENGINE	14
5. TILLER OPERATION	20
6. STOPPING THE ENGINE	24
7. MAINTENANCE	26
8. TRANSPORTING/STORAGE	37
9. TROUBLESHOOTING	38
10. SPECIFICATIONS	39
11. WARRANTY SERVICE	40

1. SAFETY INFORMATION

Read all safety instructions before operating.

⚠ WARNING

- CONTACT WITH ROTATING TINES CAN CAUSE SERIOUS INJURY. KEEP HANDS AND FEET AWAY FROM TINES WHILE ENGINE IS RUNNING.
- GASOLINE IS FLAMMABLE AND EXPLOSIVE. STOP ENGINE. AVOID HEAT, SPARKS, AND OPEN FLAME WHEN REFUELING.
- ROTARY TILLERS CAN BE HAZARDOUS IF NOT OPERATED PROPERLY. READ OWNER'S MANUAL CAREFULLY BEFORE OPERATION. Ⓢ

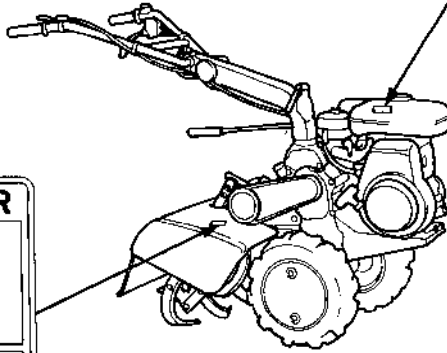

⚠ DANGER



CONTACT WITH ROTATING TINES WILL CAUSE SERIOUS INJURY. KEEP HANDS, FEET, AND CLOTHING AWAY WHILE ENGINE IS RUNNING. Ⓢ

⚠ WARNING

DO NOT OPERATE ENGINE WITH THIS COVER REMOVED. SERIOUS INJURY COULD RESULT.

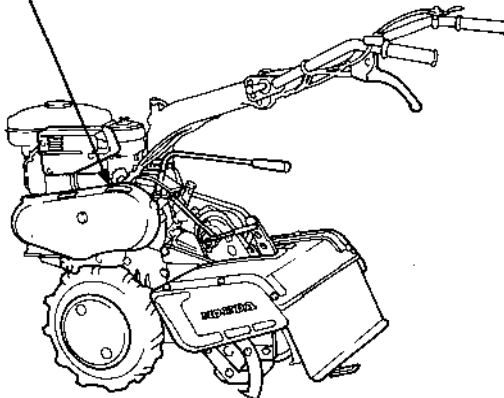

▲ WARNING**To ensure safe operation—**

For your safety and the safety of others, pay special attention to these precautions:

Operator Responsibility

- Keep the tiller in good operating condition. Operating a tiller in poor or questionable condition could result in serious injury.
- Be sure all safety devices are in working order and warning labels are in place. These items are installed for your safety.
- Be sure the safety covers (V-belt cover, chain cover and recoil starter cover) are in place.
- Know how to stop the engine and tines quickly in case of emergency. Understand the use of all controls.
- Be very cautious when operating the tiller in REVERSE, especially if attachments are being used.
- Keep a firm hold on the handlebars. They may tend to lift during clutch engagement.
- Allowing anyone to operate this tiller without proper instruction may result in injury.
- Wear sturdy, full-coverage footwear. Operating this tiller barefoot or with open toe shoes or sandals increases your risk of injury.
- Dress sensibly. Loose clothing may get caught in moving parts, increasing your risk of injury.
- Be alert. Operating this tiller when you are tired, ill or under the influence of alcohol or drugs may result in serious injury.
- Keep all persons and pets away from the tilling area.
- Be sure drag bar is in place and properly adjusted.

Child Safety

- Keep children indoors and supervised at all times when any outdoor power equipment is being used nearby. Young children move quickly and are attracted especially to the tiller and the tilling activity.
- Never assume children will remain where you last saw them. Be alert and turn the tiller off if children enter the area.
- Children should never be allowed to operate the tiller, even under adult supervision.

Rotating Tines Hazard

The rotating tines are sharp and they turn at high speed. Accidental contact can cause serious injury.

- Keep your hands and feet away from the tines while engine is running.
- Stop the engine and disengage the tine clutch before inspection or maintenance of tines.
- Disconnect the spark plug cap to prevent any possibility of accidental starting. Wear heavy gloves to protect your hands from the tines when cleaning the tines or when inspecting or replacing the tines.

Thrown Object Hazard

Objects hit by the rotating tines can be thrown from the tiller with great force, and may cause serious injury.

- Before tilling, clear the tilling area of sticks, large stones, wire, glass, etc. Till only in daylight.
- Always inspect the tiller for damage after striking a foreign object. Repair or replace any damaged parts before continuing use.
- Pieces thrown from worn or damaged tines can cause serious injury. Always inspect the tines before using the tiller.

Fire and Burn Hazard

Gasoline is extremely flammable, and gasoline vapor can explode. Use extreme care when handling gasoline. Keep gasoline out of reach of children.

- Refuel in a well-ventilated area with the engine stopped.
- Allow the engine to cool before refueling. Fuel vapor or spilled fuel may ignite.
- The engine and exhaust system become very hot during operation and remain hot for a while after stopping. Contact with hot engine components can cause burn injuries and can ignite some materials.
- Avoid touching a hot engine or exhaust system.
- Allow the engine to cool before performing maintenance or storing the tiller indoors.

Carbon Monoxide Poisoning Hazard

Exhaust contains poisonous carbon monoxide, a colorless and odorless gas. Breathing exhaust can cause loss of consciousness and may lead to death.

- If you run the engine in an area that is confined or even partially enclosed, the air you breathe could contain a dangerous amount of exhaust gas. To keep exhaust gas from building up, provide adequate ventilation.

Operation on Slope

- When tilling on slopes, keep the fuel tank less than half full to minimize fuel spillage.
- Till across the slope (At equally spaced intervals) rather than up and down it.
- Be very careful when changing the direction of the tiller on a slope.
- Do not use the tiller on a slope of more than 20°.

2. COMPONENT IDENTIFICATION

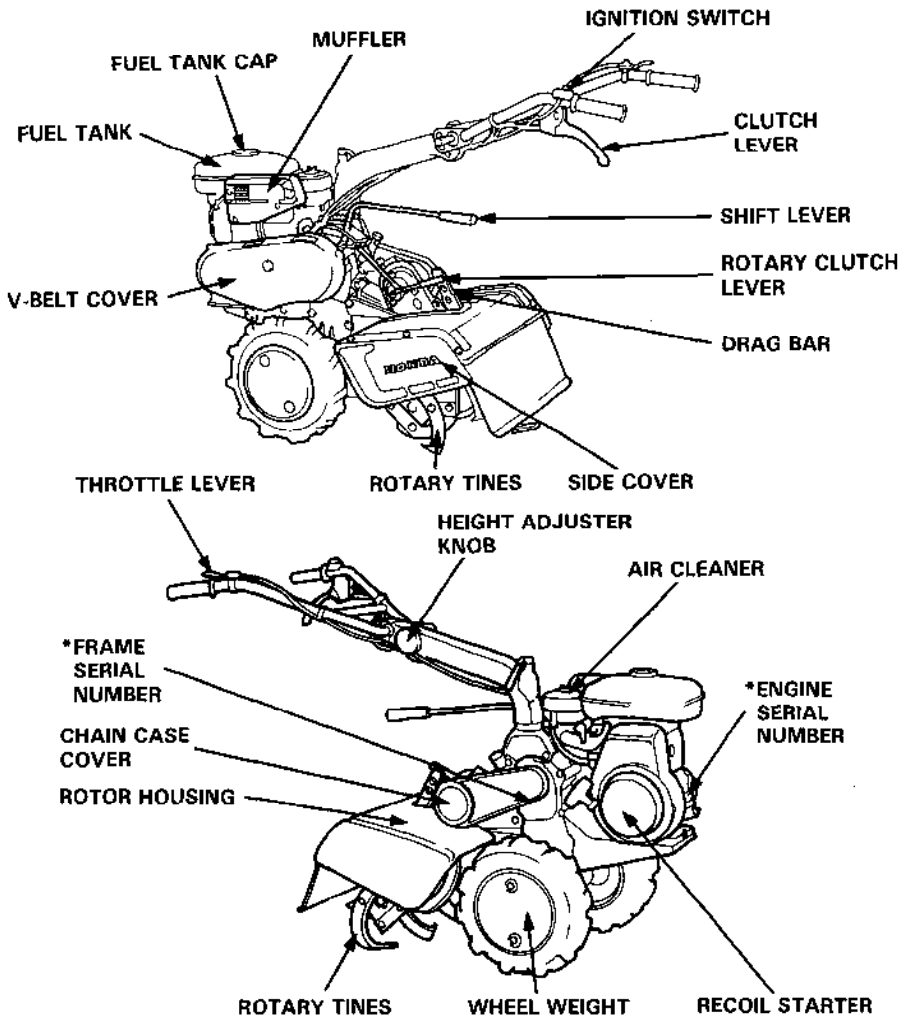

* Record the frame and engine serial numbers for your reference. Refer to the serial numbers when ordering parts, and when making technical or warranty inquiries (see page 38).

Frame serial number: _____

Engine serial number: _____

3. PRE-OPERATION CHECK

ENGINE OIL

IMPORTANT NOTICE Running the engine with low oil level will cause serious engine damage.

- Place the tiller on a level surface.
- Remove the oil filler cap and wipe the dipstick clean.
- Insert the dipstick into the oil filler neck, but do not screw it in.
- Check the oil level shown on the dipstick. If near the lower level, fill to the upper level with the recommended oil.

Use high-detergent, premium quality 4-stroke engine oil, certified to meet or exceed U.S. automobile manufacturer's requirements for API Service Classification SG, SF/CC, CD.

IMPORTANT NOTICE Using nondetergent oil or 2-stroke engine oil will shorten the engine's service life.

SAE 10W-30 is recommended for general, all-temperature use. Other viscosities shown in the following chart may be used when the average temperature in your area is within the indicated range.

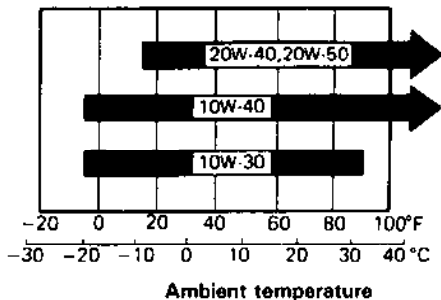

ENGINE OIL FILLER CAP

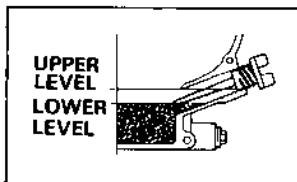
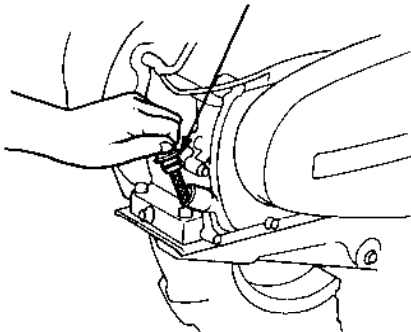

Transmission oil

With the tiller on level ground, remove the oil filler cap and to see check if oil is up to the tip of the dipstick. Add engine oil if necessary (see page 8 for recommended oil).

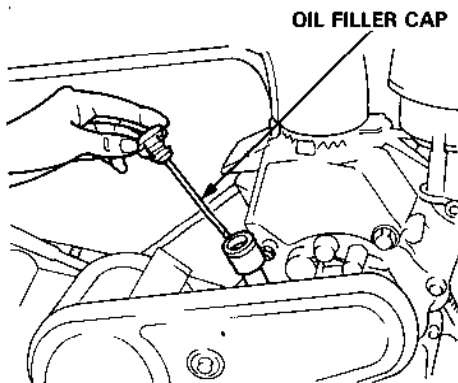

Air cleaner

Remove the cover and inspect the elements; clean them if necessary (see page 28).

With the tiller in a level position, check the case oil level. If necessary, add oil to the mark on the case see page 8 for recommended oil.

IMPORTANT NOTICE Never run the engine without the air cleaner. Rapid engine wear will result from contaminants, such as dust and dirt, being drawn through the carburetor, into the engine.

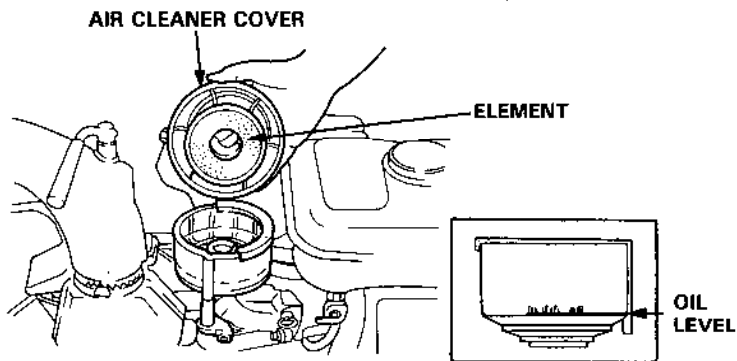

Rotary oil level

Place the tiller on level ground and remove the oil level check bolt. The oil level should be up to the lower edge of the check bolt hole. If the level is low, add engine oil until it begins to flow out of the hole (see page 8 for recommended oil).

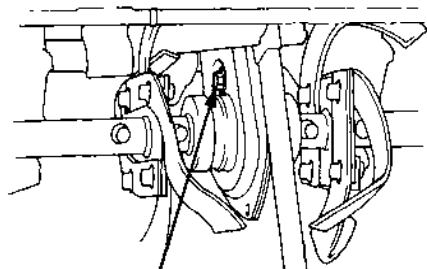

OIL LEVEL CHECK BOLT

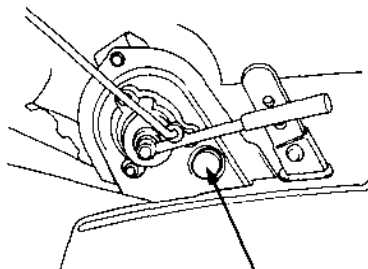

OIL FILLER CAP

FUEL

Remove the gas cap and check the fuel level. Refill the tank if the level is low.

Fuel tank capacity: FR500: 2.7 ℓ (0.74 US. gal)
FR700: 3.7 ℓ (1.0 US. gal)

▲ WARNING

Gasoline is extremely flammable, and gasoline vapor can explode. Use extreme care when handling gasoline. Keep gasoline out of the reach of children.

Refuel in a well ventilated area with the engine stopped. Keep flames and sparks away, and do not smoke in the area.

Gasoline vapors or spilled gasoline may ignite.

Refuel carefully to avoid spilling gasoline. Avoid overfilling the fuel tank (there should be no gas in the filler neck). After refueling, tighten the gas cap securely. If any gasoline was spilled, make sure the area is dry before starting the engine.

After use, park the tiller on a level surface. Be sure the storage area is well ventilated, do not allow flames or sparks in the storage area.

After refueling, be sure to tighten the GAS cap firmly.

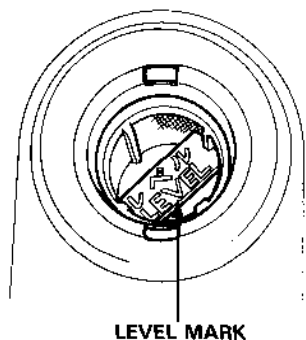
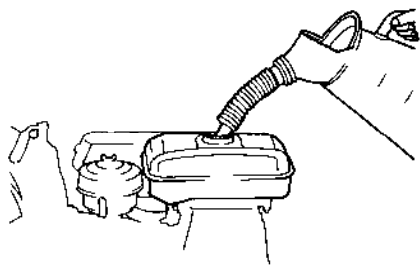

Gasoline Recommendation

Pump octane rating: 86 or higher

We recommend unleaded gasoline because it produces fewer engine and spark plug deposits and extends the exhaust system life.

If “spark knock” (metallic rapping noise) or persistent “pinging” occurs at a steady engine speed under normal load, change brands of gasoline. If spark knock or pinging persists, see an authorized Honda tiller dealer.

IMPORTANT NOTICE Running the engine with persistent spark knock or pinging can cause engine damage.

Running the engine with persistent spark knock or pinging is considered misuse, and the Distributor’s Limited Warranty does not cover parts damaged by misuse.

Occasionally you may hear light spark knock while operating under heavy loads. This is no cause for concern. It simply means your engine is operating efficiently.

Never use stale or contaminated gasoline or an oil/gasoline mixture. Avoid getting dirt or water in the gas tank.

GASOLINES CONTAINING ALCOHOL

If you decide to use a gasoline containing alcohol (gasohol), be sure its octane rating is at least as high as that recommended by Honda (see Gasoline Recommendation on page 12). There are two types of "gasohol": one containing ethanol, and the other containing methanol.

Never use gasoline containing more than 5% methanol, even if it has cosolvents and corrosion inhibitors.

IMPORTANT NOTICE Using gasohol that contains more than 10% ethanol, or gasoline containing methanol (methyl or wood alcohol) that does not also contain cosolvents and corrosion inhibitors for methanol, can cause serious fuel system damage and poor engine performance.

Honda cannot endorse the use of gasoline containing methanol since evidence of its suitability is as yet incomplete.

NOTE: Fuel system damage or engine performance problems resulting from the use of gasoline that contains alcohol is not covered under the warranty.

Before buying gasoline from an unfamiliar station, first determine if the gasoline contains alcohol; if it does, find out the type and percentage of alcohol used.

NOTE: If you notice any undesirable operating symptoms while using a gasoline that contains alcohol, or one that you think contains alcohol, switch to a gasoline that you know does not contain alcohol.

4. STARTING THE ENGINE

⚠ WARNING

- Exhaust contains poisonous carbon monoxide gas; exposure can cause loss of consciousness and may lead to death. Never run the engine in an enclosed or confined area.
- The muffler becomes very hot during operation and remains hot for a while after stopping the engine. Be careful not to touch the muffler while it is hot.

1. Turn the fuel valve ON.

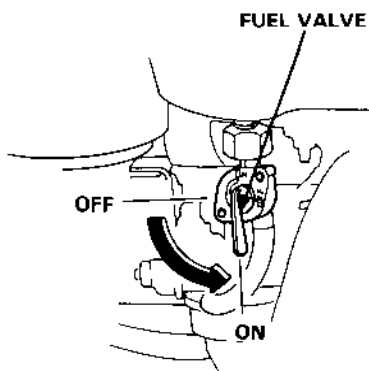

2. Turn the ignition switch to ON.

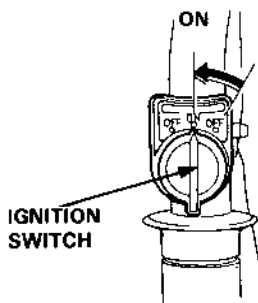

3. In cold weather and when the engine is cold, pull the choke rod to the CLOSE position.

NOTE: Do not use the choke if the engine is warm or the air temperature is high.

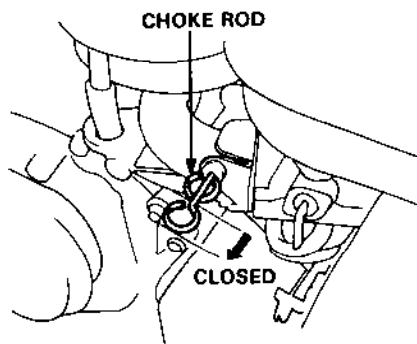

4. Move the throttle lever about 30 degrees from the extreme right (idle position).

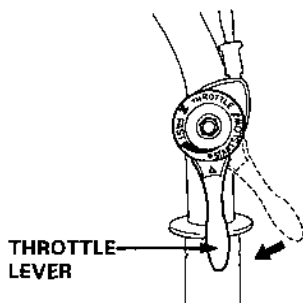

NOTE: The clutch is engaged by pulling in the clutch lever and disengaged by releasing the lever.

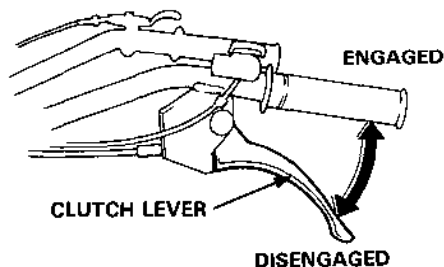

5. Make sure the clutch is disengaged and the transmission is in neutral; then pull the starter rope briskly to start the engine.

IMPORTANT NOTICE Do not allow the starter grip to snap back against the engine. Return it gently to prevent damage to the starter.

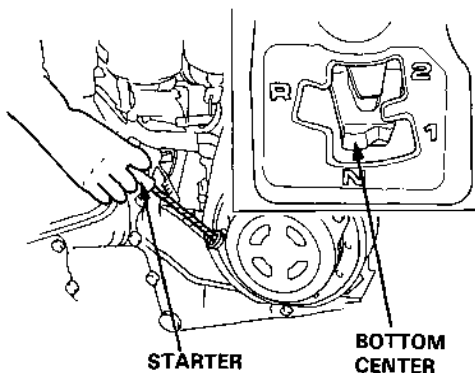

-
6. Let the engine warm up for several minutes. If the choke has been pulled out to the CLOSE position, return it gradually to the OPEN position as the engine warms up.

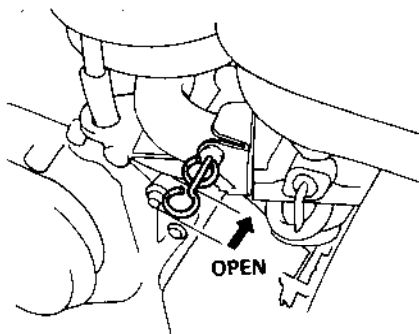

7. Move the throttle lever to the left as desired to increase engine speed.

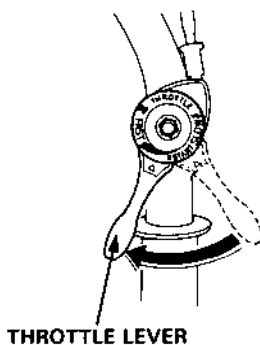

• **FR700 models with electric starter**

1. Turn the fuel valve to the ON.

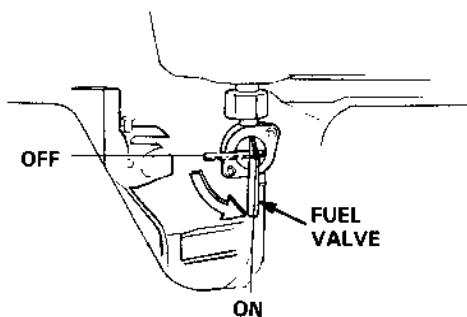

2. In cold weather and when the engine is cold, pull the choke knob to the CLOSE position.

NOTE: Do not use the choke if the engine is warm or the air temperature is high.

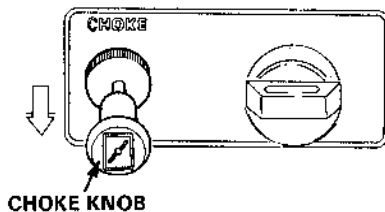

3. Move the throttle lever about 30 degrees from the extreme right (idle position).

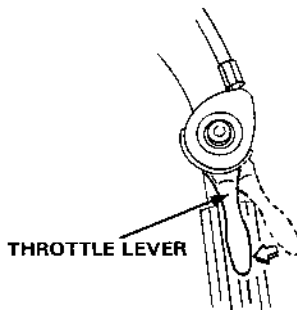

-
4. Turn the engine switch to **START** and hold it there until the engine starts.

NOTE: The battery will automatically recharge while the tiller is operated. If the tiller is not operated frequently enough to keep the battery charged, there will be a decrease in starter motor speed. If the battery is too discharged to run the starter motor, use the recoil starter.

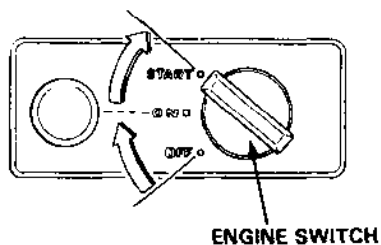

5. After the engine starts, let the engine switch return to **ON**.

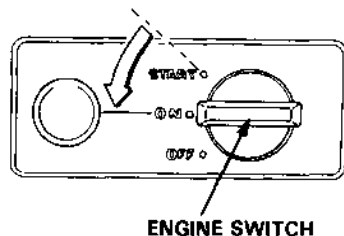

6. Let the engine warm up for several minutes. If the choke has been pulled out to the **CLOSE** position, return it gradually to the **OPEN** position as the engine warms up.

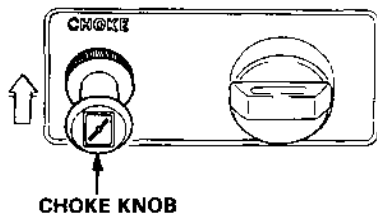

-
7. Move the throttle lever to the left as desired to increase engine speed.

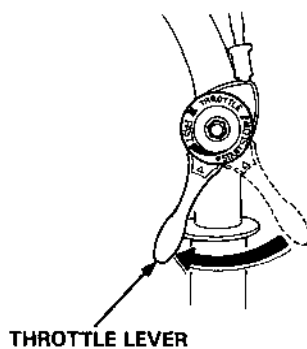

5. TILLER OPERATION

BEFORE ADJUSTING THE HANDLEBAR, BE SURE THE ENGINE IS OFF.

1. Handlebar height adjustment

IMPORTANT NOTICE Before adjusting the handlebar, place the tiller on firm, level ground to prevent the handle from collapsing accidentally.

To adjust the handlebar height, loosen the adjuster knob, select the appropriate holes in the handle column and handlebar bracket, and tighten the knob.

HEIGHT ADJUSTER KNOB

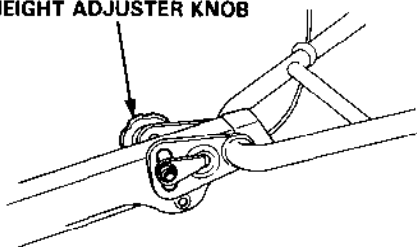

2. Handlebar Angle Adjustment

The column can be adjusted at two different angles in either direction. To adjust, loosen the angle adjuster and move the column. After adjustment, be sure to tighten the adjuster securely.

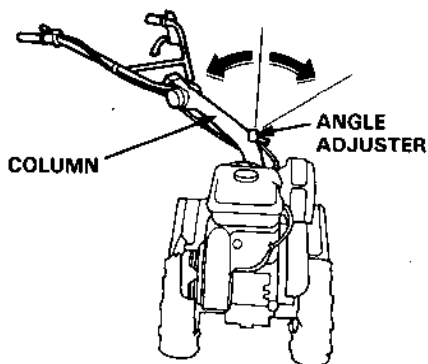

3. Tilling depth adjustment

BEFORE ADJUSTING THE TILLING DEPTH, BE SURE THE ENGINE IS OFF.

The tilling depth adjustment can be made by removing the retainer and sliding the drag bar up or down.

If breaking ground for the first time, lower the drag bar all the way. As the soil becomes softer, the drag bar can be raised.

If not sure about soil conditions, start with the drag bar in the lowest position.

DRAG BAR

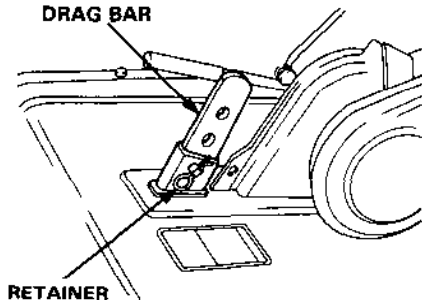

4. Rotary Clutch Operation/Tilling

To work the tiller

1. Start the engine.
2. With the throttle at idle and the clutch disengaged, select a forward gear.
3. Return the throttle to the engine start position (about 30° from idle), and engage the clutch.
4. Move the rotary clutch forward (position 1) and the tines will turn.
5. Increase engine speed as necessary.

To stop the tiller

1. Move the rotary clutch to (position 2) and stop the engine.

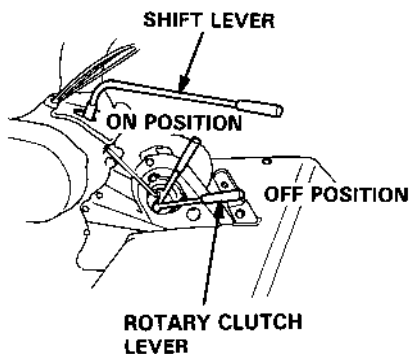

5. Gear Selection

The transmission has two forward speeds and one reverse speed.

CAUTION Return the throttle lever to the idle position and disengage the clutch before moving the shift lever. Avoid using excessive force on the shift lever.

1. Move the throttle lever to the idle position (extreme right).
2. Release the clutch lever and move the shift lever to the desired position.

Neutral	bottom center
Forward 1st	right of neutral
Forward 2nd	fully up from neutral and toward the right
Reverse	up to the center from neutral and to the left

NOTE: If the shift lever will not engage the desired gear, engage the clutch and move the tiller slightly to reposition the gears.

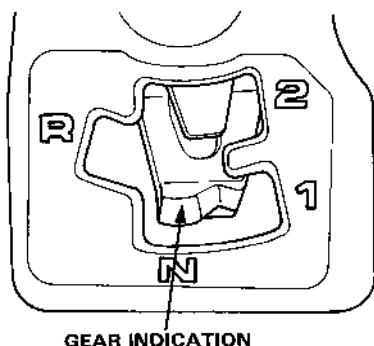
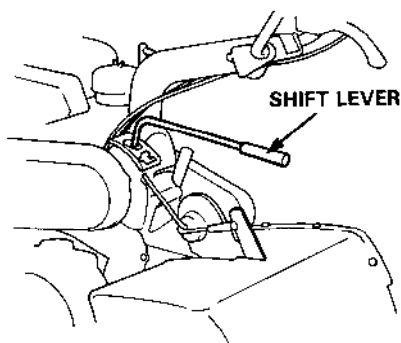

6. Wheel Weight Installation

The wheel weights improve traction on soft or marshy ground. To install the weights, insert two bolts and secure them with the nuts supplied. Tighten the bolts and nuts securely to prevent them from loosening during operation.

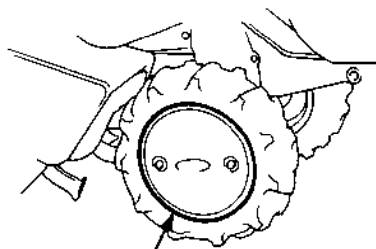

WHEEL WEIGHT

7. Tire Pressure

Excessive tire pressure will reduce traction, and underinflation may result in abnormal or accelerated tire wear. For best performance, keep the tires inflated to 1.2 kg/cm² (17.1 psi).

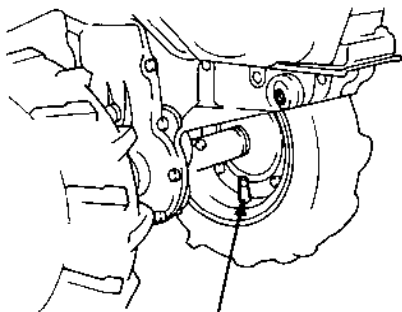

TIRE VALVE

8. Rotary tine inspection/replacement

⚠ WARNING

Wear heavy gloves to protect your hands.

Check for worn, bent or other damaged of the rotary tines.

Check for damage dor loose bolts and nuts.

Tighten and/or replace them if necessary.

IMPORTANT NOTICE

Use only a genuine HONDA replacement rotary tine.
Rotary tine A and rotary tine B are not interchangeable.

Bolt and nut directions

Rotary tine locations

10 mm BOLTS

10 mm NUTS/
10 mm SPRING WASHERS

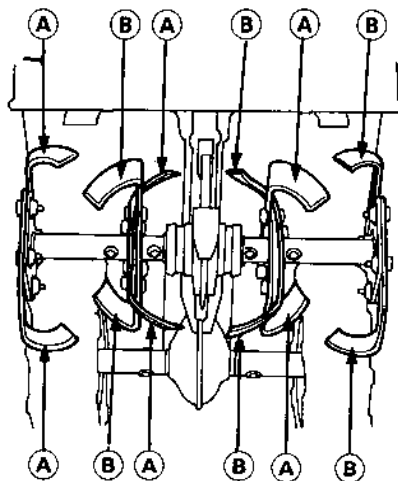
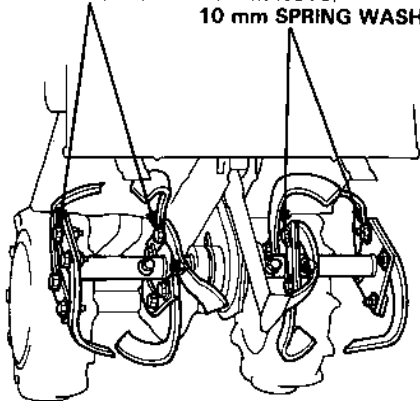

6. STOPPING THE ENGINE

1. Move the throttle to the idle position (Extreme right).
2. Release the clutch lever and move the shift lever to the "N" (Neutral) position.

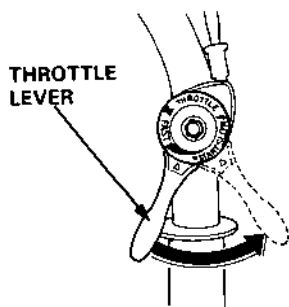

3. Turn the ignition switch OFF to stop engine.

Recoil starter type

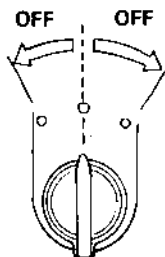

Electric starter type

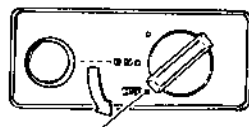

4. Turn the fuel valve OFF.

NOTE: To stop the engine in an emergency, release the clutch lever and turn the ignition switch OFF.

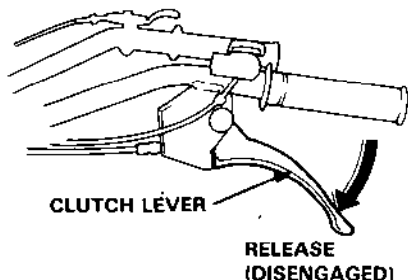
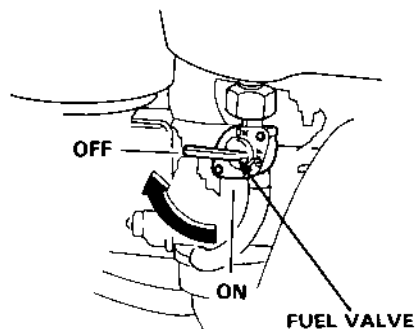

High Altitude Operation

At high altitude, the standard carburetor air-fuel mixture will be too rich. Performance will decrease, and fuel consumption will increase. A very rich fuel mixture may also foul the spark plugs and cause hard starting.

High altitude performance can be improved by installing a smaller diameter main fuel jet in the carburetor and readjusting the pilot screw. If you always operate the engine at altitudes higher than 6,000 feet above sea level, have an authorized Honda tiller dealer perform this carburetor modification.

Even with carburetor modification, engine horsepower will decrease about 3.5% for each 1,000 feet increase in altitude. The effect of altitude on horsepower will be greater than this if no carburetor modification is made.

IMPORTANT NOTICE Once a carburetor is jetted for high altitude use, operation at lower altitudes without rejetting may result in reduced performance, overheating, and serious engine damage.

It is especially important to rejet a carburetor when going from a higher altitude to a lower one. At lower altitudes, the air/fuel mixture may become excessively lean.

7. MAINTENANCE

The purpose of the maintenance schedule is to keep the tiller in the best operating condition. Inspect or service as scheduled in the table below.

▲WARNING Shut off the engine before performing any maintenance. Exhaust contains poisonous carbon monoxide gas; Exposurs can cause loss of consciousness and may lead to death. If the engine must be run, make sure the area is well ventilated.

IMPORTANT NOTICE Use only genuine HONDA parts or their equivalent for maintenance or repair. Replacement parts which are not of equivalent quality may damage the tiller.

Maintenance Schedule

ITEM	REGULAR SERVICE PERIOD Perform at every indicated month or operating interval, whichever comes first.	EACH USE	FIRST MONTH OR 20 HRS	EVERY 3 MONTHS OR 50 HRS	EVERY 6 MONTHS OR 100 HRS	EVERY YEAR OR 300 HRS
Engine oil	Check level	○				
	Change		○		○	
Transmission oil	Check level	○				
Rotary oil	Check	○				
Air cleaner and air cleaner oil	Check	○				
Air cleaner oil	Change			○(1)		
Belt tension	Adjust		○		○	
Spark plug	Clean-Readjust				○	
Sediment cup	Clean				○	
Throttle cable	Adjust					○
Clutch cable	Adjust		○		○	
Valve clearance	Check-Readjust					○(2)
Combustion chamber and valves	Clean-Relap					○(2)
Fuel tank	Clean					○(2)
All fasteners (for tightness)	Check-Retighten	○ Initial 10 Hrs			○	
Fuel line	Check (Replace if necessary)	Every 2 years (2)				

NOTE: (1) Service more frequently when used in dusty areas.

(2) These items should be serviced by an authorized Honda dealer, unless the owner has the proper tools and is mechanically proficient. See the Honda Shop Manual.

1. Engine oil change

NOTE: Change the oil when the engine is warm to assure rapid and complete draining.

1. Remove the oil drain bolt and the filler cap.
2. Tilt the engine forward slightly and allow all of the oil to drain.
3. Reinstall and tighten the oil drain bolt and fill engine with oil to the upper oil level (See page 8 for recommended oil).
4. Reinstall and tighten the filler cap.

OIL CAPACITY: FR500-0.7 ℓ (0.74 US qt)
FR700-1.2 ℓ (1.3 US qt)

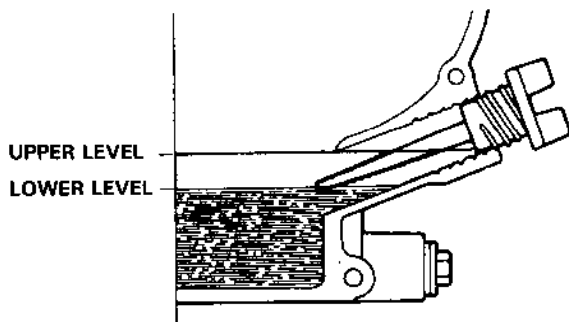
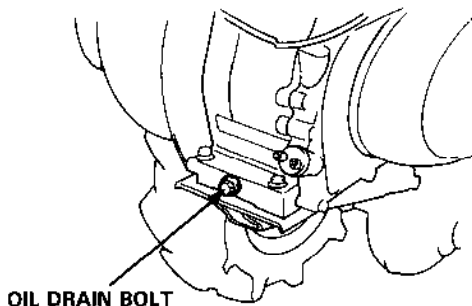

CAUTION Used motor oil may cause skin cancer if repeatedly left in contact with the skin for prolonged periods. Although this is unlikely unless you handle used oil on a daily basis, it is still advisable to thoroughly wash your hands with soap and water as soon as possible after handling used oil.

NOTE: Please dispose of used motor oil in manner that is compatible with the environment. We suggest you take it in a sealed container to your local service station for reclamation. Do not throw it in the trash or pour it on the ground.

2. Air cleaner service

A dirty air cleaner will restrict air flow to the carburetor. To prevent carburetor malfunction, service the air cleaner regularly. Service more frequently when operating the engine in extremely dusty areas.

WARNING Never use gasoline or low flash point solvents for cleaning the air cleaner element. A fire or explosion could result.

IMPORTANT NOTICE Never run the engine without the air cleaner. Rapid engine wear will result.

1. Remove the air cleaner cover. Remove and clean the elements in non-flammable or high flash point solvent. Allow the elements to dry.
2. Saturate the elements with oil and squeeze out any excess.
3. Empty the oil from the air cleaner case and wash out any accumulated dirt with solvent. Dry the case.
4. Fill the case to the oil level shown on page 9 (See page recommended oil).
5. Reassemble and reinstall the air cleaner.

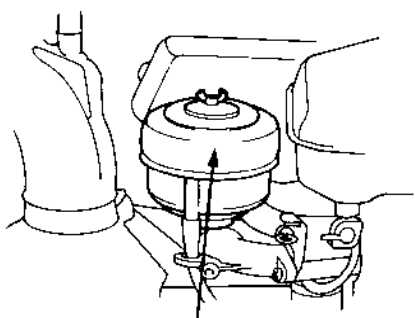

AIR CLEANER COVER

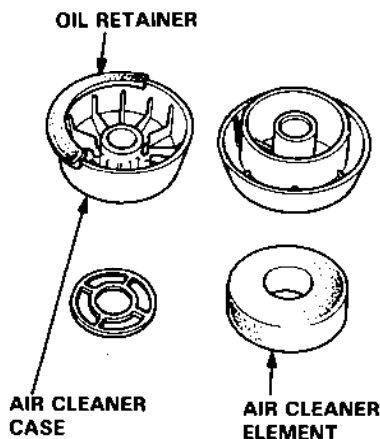

3. Clean sediment cup

Turn the fuel valve to the off position and remove the sediment cup and O-ring.

Wash removed parts in solvent, dry them thoroughly and reinstall them securely. Turn the fuel valve ON and check for leaks.

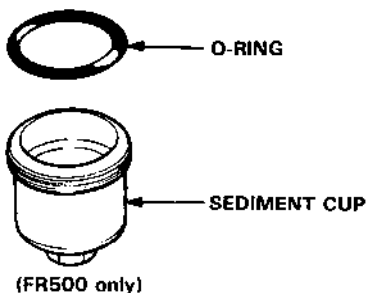

4. Transmission oil change

NOTE: Change the oil when the engine is warm to assure rapid and complete draining.

1. Remove the oil filler cap and drain bolt, and allow the oil to drain.
2. Reinstall the drain bolt and fill the transmission case up to the tip of the filler cap/dipstick with recommended oil (See page 8).
3. Reinstall the filler cap.

OIL CAPACITY: 1.1 l (1.2 US qt)

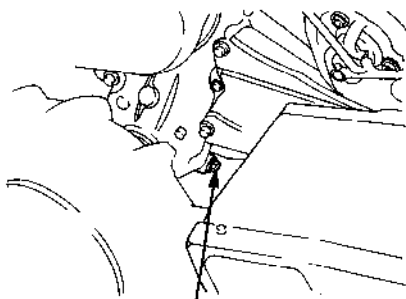
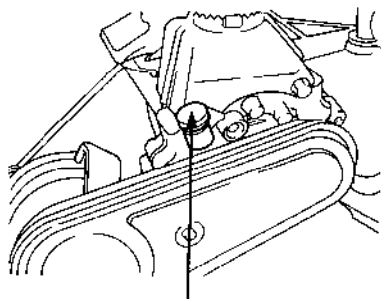

5. Rotary oil level

1. Place the tiller on level ground and remove the oil level check bolt.
2. Remove the oil filler cap.
The oil level should be up to the lower edge of the check bolt hole.
3. If the level is low, add oil until it begins to flow out of the hole (See page 8 for recommended oil).

OIL CAPACITY: 0.35 (0.38 US qt)

4. Tighten the check bolt securely.
5. Install the oil filler cap.

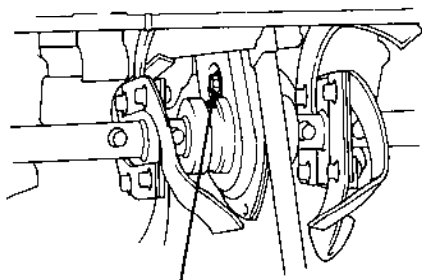

OIL CHECK BOLT

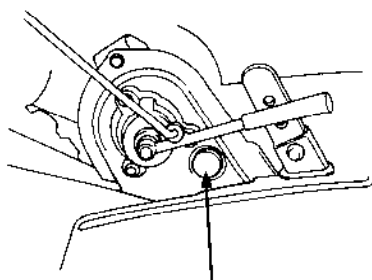

OIL FILLER CAP

6. Spark plug service.

Recommended spark plug: BR-4HS (NGK),
W14 FR-U (ND)

To ensure proper engine operation, the spark plug must be properly gapped and free of deposits.

1. Clean any dirt from around the spark plug base.
2. Remove the spark plug cap and use the spark plug wrench to remove the spark plug.

▲ WARNING If the engine has been running, the muffler will be very hot. Be careful not to touch the muffler.

SPARK PLUG WRENCH

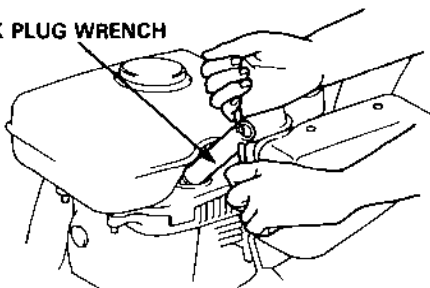

3. Visually inspect the spark plug. Discard it if the insulator is cracked or chipped. Clean the spark plug with a wire brush if it is to be reused.
4. Measure the plug gap with a feeler gauge. The gap should be 0.6–0.7 mm (0.024–0.028 in). Correct as necessary by bending the side electrode.

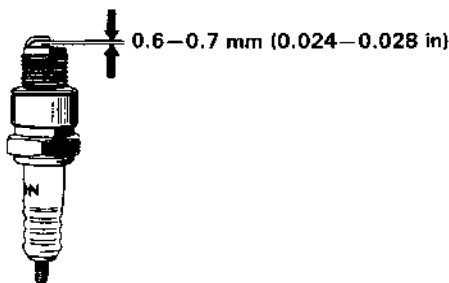

5. Attach the plug washer. Thread the plug in by hand to prevent cross-threading.

SPARK PLUG WRENCH

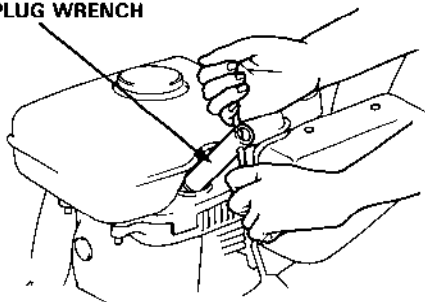

6. Tighten a new spark plug 1/2 after the plug seats turn with the wrench to compress the washer. If you are reusing a plug, it should only take 1/8–1/4 turn after the plug seats.

IMPORTANT NOTICE The spark plug must be securely tightened. An improperly tightened plug can become very hot and possibly damage the engine. Never use a spark plug with an improper heat range.

7. Throttle cable adjustment

Loosen the lock nut and turn the throttle cable adjusting nut until free play at the throttle lever is between 5–10 mm (1/4–3/8 in) as shown. Tighten the lock nut securely.

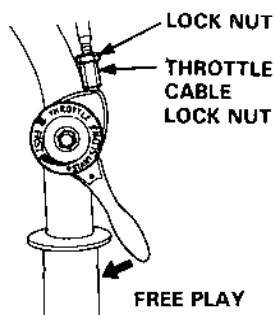

8. Clutch Cable Adjustment

1. Remove the V-belt cover.
2. Loosen clutch cable the lock nut and turn the adjusting nut so that distance (A) is within the following limits, when the clutch is disengaged.

	FR500	FR700
(A)	63–65 mm (2.48–2.56 in)	50–52 mm (1.97–2.05 in)

3. After adjustment, tighten the lock nut securely, and replace the V-belt cover. Then start the engine and check for proper clutch level operation.

NOTE: If the distance A measurement can't be set by the adjustment, the belts are probably worn beyond use and should be replaced. Always replace both belts as a set.

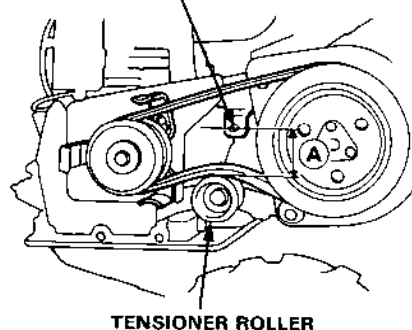
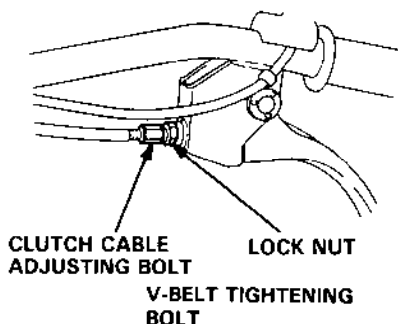

9. V-belt Adjustment

1. Remove the cover.
2. Engage the clutch and measure distance (A), it should be within the limits shown. To adjust, loosen five engine mounting bolts and shift the engine forward to tighten the belts.

	FR500	FR700
(A)	75–78 mm (2.95–3.07 in)	75–78 mm (2.95–3.07 in)

Tighten the bolts securely.

3. Measure clearances (B) and (C) to see if they fall within the following specifications:

(B) 3–5 mm (0.12–0.20 in)

(C) 6–8 mm (0.24–0.32 in)

To adjust, loosen the belt stopper tightening bolts and slide the stoppers as required.

4. Tighten the bolts securely and reinstall the cover.

NOTE: If the clearances can't be obtained by adjustment, the belts are worn beyond use and should be replaced. Always replace both belts as a set.

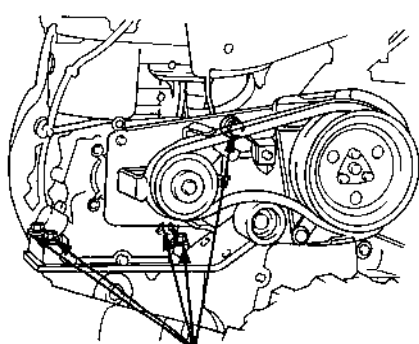

ENGINE MOUNTING BOLTS

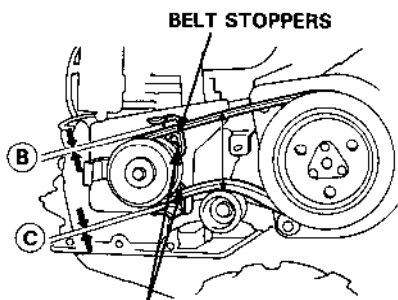

BELT STOPPERS

STOPPER TIGHTENING BOLTS

10. Upper chain adjustment

1. Remove the primary chain case cover.
2. Check chain slack midway between the sprockets; it should be 20–30 mm (0.79–1.18 in). To adjust tension, loosen the tensioner adjusting bolts and move the tensioner up or down as necessary.

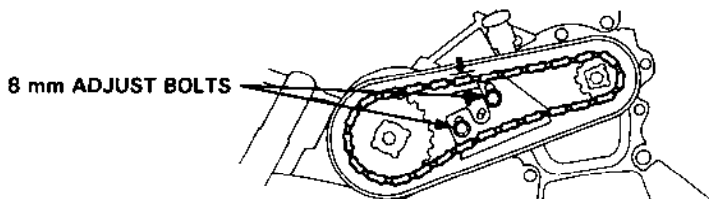

11. Fuse replacement (FR700 with electric starter)

If the fuse has blown, replace it with a 5A fuse after checking the cause. If the fuse is changed without finding the cause, the new fuse may blow again.

IMPORTANT NOTICE Do not substitute a higher capacity fuse, and do not use a wire or other material in place of the fuse; using a fuse that is rated higher than recommended can damage the electrical system.

NOTE: When the fuse case cover is removed, 2 fuses can be seen. One of these is the spare fuse. Use it to replace the blown fuse.

12. Fastener Tightness Check

Check to be sure if all the fasteners are tight. If not, retighten them.

Tightening points are as follows:

- Upper chain case to rotary case
- Transmission to rotary frame
- Rotary cover to rotary frame
- Swing base to transmission

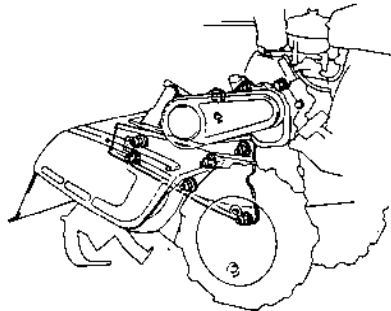

13. Battery Service

Recharge the battery if the tiller is to be stored for an extended period of time.

During the storage, the battery should also be recharged every 6 months. To recharge the battery, use a commercially available battery charger whose max. Charging current is rated below 3 A.

The tiller is equipped a maintenance-free battery which does not require checking and refilling of the battery fluid. Under no circumstances should the caps be removed from the battery cells.

1. Remove the battery from the tiller when recharging the battery.
2. Disconnect the negative (-) cable from the battery first, then disconnect the positive (+) cable.
3. Battery charging time: Approx. 5 hours
at 1.2 A (standard)
4. Before recharging the battery, check the terminals for corrosion. Any corrosion around the positive and negative terminals should be washed off with a solution of baking soda and warm water. Dry the terminals and then coat them with grease.
5. After reinstalling the battery, be sure to tighten the terminals securely.

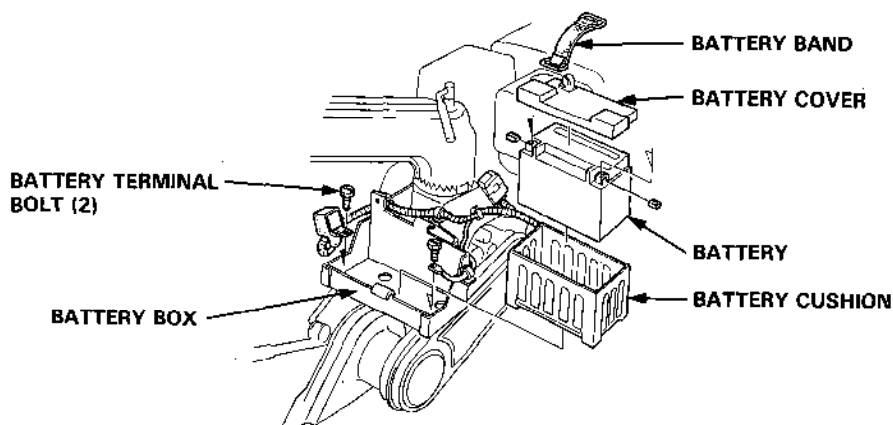

⚠ WARNING

- The battery gives off explosive gases; keep sparks, flames and cigarettes away. Provide adequate ventilation when charging or using the batteries in an enclosed space.
- The battery contains sulfuric acid (electrolyte). Contact with skin or eyes may cause severe burns. Wear protective clothing and a face shield.
 - If electrolyte gets on your skin, flush with water.
 - If electrolyte gets in your eyes, flush with water for at least 5 minutes and call a physician immediately.

8. TRANSPORTING/STORAGE

▲ WARNING When transporting the tiller, turn the fuel valve OFF and keep the tiller level to prevent fuel spillage. Fuel vapor or spilled fuel may ignite.

Before storing the unit for an extended period;

1. Be sure the storage area is free of excessive humidity and dust.
2. Drain the fuel ...
 - a. With the fuel valve turned OFF, remove and empty the sediment cup.
 - b. Turn the fuel valve ON and drain the gasoline in the fuel tank into a suitable container.
 - c. Replace the sediment cup and tighten securely.
 - d. Drain the carburetor by removing the drain screw.
Drain the gasoline into a suitable container. Replace the drain screw.

▲ WARNING Gasoline is flammable and explosive under certain conditions. Do not smoke or allow flames sparks near the equipment while draining fuel.

3. Drain the engine oil and refill the engine with fresh oil.
4. Clean the tiller and coat areas of possible rust with a light film of oil.
5. Coat the cylinder walls with oil. (If anticipated storage will exceed 1 year.)
6. Remove the spark plug and pour two or three tablespoonsful of clean oil into the cylinder. Pull the starter handle slowly to distribute the oil over the cylinder walls. Leave the piston on compression to close the valves and points. Reinstall the spark plug.
7. Close the IN. & EX. valves and the contact breaker points.
 - a. Pull the starter handle until it becomes hard to pull (the piston is coming up on the compression stroke). Both valves and the contact breaker points will be closed. This will protect the valve seats and the points from corrosion.

Align the notch on the starter pulley with the hole at the top of recoil starter.

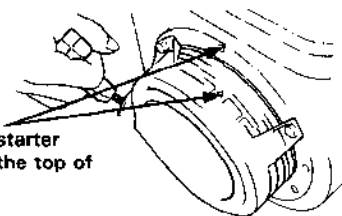

8. Cover the tiller and store on a level surface in a dry, dust-free area.
9. Once a month, recharge the battery (FR700 models with electric starter).

9. TROUBLESHOOTING

When the engine will not start;

1. Is there enough fuel?
2. Is the fuel valve ON?
3. Is the engine switch ON?
4. Is gasoline reaching the carburetor?

To check, loosen the drain screw with the fuel valve on. Fuel should flow out freely. Retighten drain screw.

▲ WARNING If any fuel is spilled, make sure the area is dry before testing the spark plug or starting the engine. Fuel vapor or spilled fuel may ignite.

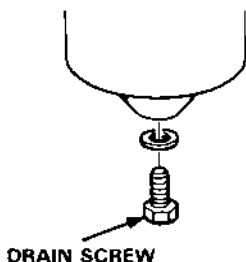

5. Is there a spark at the spark plug?

- a. Remove the spark plug cap. Clean any dirt from around the spark plug base, then remove the spark plug.
- b. Install the spark plug in the plug cap.
- c. Turn the engine switch on.
- d. Grounding the side electrode to any engine ground, pull the recoil starter to see if sparks jump across the gap.

▲ WARNING

- Never hold the spark plug lead with wet hands while performing this test.
 - Make sure that no fuel has been spilled on the engine and that the plug is not wet with fuel.
 - To avoid fire hazards, do not allow sparks near the plug hole.
- e. If there is no spark, replace the plug.
If OK, try to start the engine according to the instructions.

6. If the engine still does not start, take the tiller to an authorized Honda dealer.

10. SPECIFICATIONS

Model	FR500	FR700
Dimensions (L × W × H)	1,340 × 620 × 960 mm (52.8 × 24.4 × 37.8 in)	A: 1,510 × 620 × 980 mm (59.4 × 24.4 × 38.4 in), AS: 1,595 × 620 × 980 mm (62.7 × 24.4 × 38.4 in)
Dry weight	100 kg (220.5 lb)	A: 115 kg (253.6 lb), AS: 121 kg (266.8 lb)
Tire size	350-7	
Maximum handle height	1,230 mm (48.4 in)	1,290 mm (50.8 in)
Engine Model	G200	G300
Type	Single cylinder, 4-stroke forced air cooled, side valve, gasoline	
Displacement/Bore and stroke	197 cm ³ (12.0 cu in) 67 × 56 mm (2.6 × 2.2 in)	272 cm ³ (16.6 cu in) 76 × 60 mm (3.0 × 2.4 in)
Ignition timing	20° BTDC, fixed	
Ignition system	Flywheel magneto	
Engine oil capacity	0.7 ℓ (0.74 US qt)	1.2 ℓ (1.3 US qt)
Fuel tank capacity	2.7 ℓ (0.7 US gal.)	3.7 ℓ (1.0 US gal.)
Spark plug	BR-4HS (NGK), W14FR-U (ND)	
Clutch	Belt tension	
Transmission	Two speeds forward and one reverse speed	
Oil capacity	1.1 ℓ (1.2 US qt)	
Rotary		
Dry weight	30 kg (66.2 lb)	
Tilling depth control	Adjustable dragbar	
Tine shaft speed	243 rpm	
Tilling pitch	22-43 mm (0.9-1.7 in)	
Tilling width	500 mm (20 in) [Standard] 627 mm (25 in) [Optional]	
Tine turning diameter	100 mm (40 in) [Standard]	
No. of tines	6 on each side (Standard) 8 on each side (Optional)	
Oil capacity	0.35 ℓ (0.37 US qt)	

11. WARRANTY SERVICE

Owner Satisfaction

Your satisfaction and goodwill are important to your dealer and to us. All Honda warranty details are explained in the Distributor's Limited Warranty. Normally, any problems concerning the product will be handled by your dealer's service department. If you have a warranty problem that has not been handled to your satisfaction, we suggest you take the following action:

- Discuss your problem with a member of dealership management. Often complaints can be quickly resolved at that level. If the problem has already been reviewed with the Service Manager, contact the owner of the dealership or the General Manager.
- If your problem still has not been resolved to your satisfaction, contact:

American Honda Motor Co., Inc.
P.O. Box 50
Gardena, California 90247-0805
Telephone: (213) 604-2400

We will need the following information in order to assist you:

- Your name, address, and telephone number
- Product model and serial number
- Date of Purchase
- Dealer name and address
- Nature of problem

After reviewing all the facts involved, you will be advised of what action can be taken. Please bear in mind that your problem will likely be resolved at the dealership, using the dealer's facilities, equipment, and personnel, so it is very important that your initial contact be with the dealer.

Your purchase of a Honda product is greatly appreciated by both your dealer and American Honda Motor Co., Inc. We want to assist you in every way possible to assure your complete satisfaction with your purchase.

HONDA
HONDA MOTOR CO., LTD. TOKYO, JAPAN

31723610
00X31-723-6102

AP 5009009 K1
PRINTED IN JAPAN