

HONDA

Power

Equipment

Owner's Manual

TILLER

F220

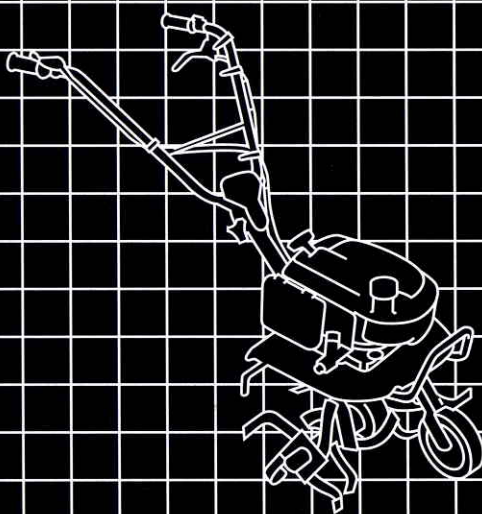



WARNING:



The engine exhaust from this product contains chemicals known to the State of California to cause cancer, birth defects, or other reproductive harm.

Keep this owner's manual handy, so you can refer to it any time. This owner's manual is considered a permanent part of the tiller and should remain with the tiller if resold.

The information and specifications included in this publication were in effect at the time of approval for printing. Honda Motor Co., Ltd. reserves the right, however, to discontinue or change specifications or design at any time without notice and without incurring any obligation whatever.

INTRODUCTION

Congratulations on your selection of a Honda tiller. We are certain you will be pleased with your purchase of one of the finest tillers on the market.

We want to help you get the best results from your new tiller and to operate it safely. This manual contains all the information on how to do that; please read it carefully.

As you read this manual, you will find information preceded by a **NOTICE** symbol. That information is intended to help you avoid damage to your tiller, other property, or the environment.

We suggest you read the warranty policy to fully understand its coverage and your responsibilities of ownership. The warranty policy is a separate document that should have been given to you by your dealer.

When your tiller needs scheduled maintenance, keep in mind that your Honda servicing dealer is specially trained in servicing Honda tillers and is supported by the parts and service divisions of American Honda. Your Honda servicing dealer is dedicated to your satisfaction and will be pleased to answer your questions and concerns.

Best Wishes,
Honda Motor Co., Ltd.

INTRODUCTION

A FEW WORDS ABOUT SAFETY

Your safety and the safety of others are very important. And using this tiller safely is an important responsibility.

To help you make informed decisions about safety, we have provided operating procedures and other information on labels and in this manual. This information alerts you to potential hazards that could hurt you or others.

Of course, it is not practical or possible to warn you about all the hazards associated with operating or maintaining a tiller. You must use your own good judgment.

You will find important safety information in a variety of forms, including:

- **Safety Labels** — on the tiller.
- **Safety Messages** — preceded by a safety alert symbol  and one of three signal words: DANGER, WARNING, or CAUTION.

These signal words mean:

 **DANGER**

You **WILL** be **KILLED** or **SERIOUSLY HURT** if you don't follow instructions.

 **WARNING**

You **CAN** be **KILLED** or **SERIOUSLY HURT** if you don't follow instructions.

 **CAUTION**

You **CAN** be **HURT** if you don't follow instructions.

- **Safety Headings** — such as *IMPORTANT SAFETY INFORMATION*.
- **Safety Chapter** — such as *TILLER SAFETY*.
- **Instructions** — how to use this tiller correctly and safely.

This entire book is filled with important safety information — please read it carefully.

CONTENTS

TILLER SAFETY	5
IMPORTANT SAFETY INFORMATION	5
SAFETY LABEL LOCATIONS	8
CONTROLS	9
COMPONENT & CONTROL LOCATIONS	9
CONTROLS	10
Fuel Valve	10
Choke Lever	10
Engine Switch	10
Starter Grip	11
Throttle Lever	11
Handlebar Height Adjuster	11
Main Clutch Lever	12
Drag Bar	12
Front Wheel	12
BEFORE OPERATION	13
ARE YOU READY TO GET STARTED?	13
IS YOUR TILLER READY TO GO?	13
Check the Engine	14
Check the Tiller	14
OPERATION	15
SAFE OPERATING PRECAUTIONS	15
STARTING THE ENGINE	16
OPERATING THE CONTROLS FOR TILLING	19
STOPPING THE ENGINE	21
SERVICING YOUR TILLER	22
THE IMPORTANCE OF MAINTENANCE	22
MAINTENANCE SAFETY	23
MAINTENANCE SCHEDULE	24
REFUELING	25
FUEL RECOMMENDATIONS	26
ENGINE OIL LEVEL CHECK	27
ENGINE OIL CHANGE	28
ENGINE OIL RECOMMENDATIONS	29
TRANSMISSION OIL LEVEL CHECK	30
AIR FILTER INSPECTION	31
AIR FILTER CLEANING	32
SPARK PLUG SERVICE	33

CONTENTS

SERVICING YOUR TILLER (continued)

CLUTCH CABLE ADJUSTMENT	35
THROTTLE CABLE ADJUSTMENT	35
SPARK ARRESTER SERVICE (optional equipment)	36

STORAGE

STORAGE PREPARATION	37
Cleaning	37
Fuel	39
Engine Oil	41
STORAGE PRECAUTIONS	42
REMOVAL FROM STORAGE	42

TRANSPORTING

BEFORE LOADING	43
LOADING AND UNLOADING	43

TAKING CARE OF UNEXPECTED PROBLEMS

ENGINE PROBLEMS	44
Engine Will Not Start	44
Engine Lacks Power	45
TILLING PROBLEMS	46
Poor Tilling Quality	46

TECHNICAL & CONSUMER INFORMATION

TECHNICAL INFORMATION	47
Serial Number Locations	47
Carburetor Modification for High Altitude Operation	48
Emission Control System Information	49
Specifications	51
CONSUMER INFORMATION	52
Honda Publications	52
Customer Service Information	53

QUICK REFERENCE INFORMATION Inside back cover

TILLER SAFETY

IMPORTANT SAFETY INFORMATION

Honda tillers are designed to cultivate earth outdoors. Other uses can result in injury to the operator or damage to the tiller and other property.

Most accidents can be prevented if you follow all instructions in this manual and on the tiller. The most common hazards are discussed below, along with the best way to protect yourself and others.

Operator Responsibility

- Know how to stop the tiller quickly in case of emergency.
- Understand the use of all tiller controls.
- Keep a firm hold on the handlebars. They may tend to lift during clutch engagement.
- Be sure the drag bar is in place and properly adjusted.
- Be sure that anyone who operates the tiller receives proper instruction. Do not let children operate the tiller. Keep children and pets away from the area of operation.

Carbon Monoxide Hazard

- Exhaust contains poisonous carbon monoxide, a colorless, odorless gas. Breathing carbon monoxide can cause loss of consciousness and may lead to death.
- If you run the tiller in a confined or even partially enclosed area, the air you breathe could contain dangerous amounts of carbon monoxide. To keep carbon monoxide from building up, provide adequate ventilation.

TILLER SAFETY

Fire and Burn Hazards

- The exhaust system gets hot enough to ignite some materials.
 - Keep the tiller at least 3 feet (1 meter) away from buildings and other equipment during operation.
 - Keep flammable materials away from the tiller.
- The muffler becomes very hot during operation and remains hot for a while after stopping the engine. Be careful not to touch the muffler while it is hot. Let the engine cool before storing the tiller indoors.

Refuel With Care

Gasoline is extremely flammable, and gasoline vapor can explode. Allow the engine to cool if the tiller has been in operation. Refuel only outdoors in a well-ventilated area with the engine OFF. Do not overfill the fuel tank. Never smoke near gasoline, and keep other flames and sparks away.

Always store gasoline in an approved container. Make sure that any spilled fuel has been wiped up before starting the engine.

Avoid Rotating Tines

Rotating tines can cause serious cuts and even amputate body parts. Keep away from the tine area whenever the engine is running. If you need to work around the tines to clear object accumulation or for any other reason, always shut off the engine. Disconnect the spark plug cap, and wear heavy gloves when you need to clean the tine area or handle the tines.

Clear Tilling Area

A tine can throw rocks and other objects with enough force to cause serious injury. Before tilling, carefully inspect the area and remove all stones, sticks, bones, nails, pieces of wire, and other loose objects. Be aware if children are in the area; stop the tiller. Never operate the tines over gravel.

Keep Shields in Place

Guards and shields are designed to protect you from being hit by thrown objects and to keep you from touching hot engine parts and moving components. For your safety and the safety of others, keep all shields in place when the engine is running.

Wear Protective Clothing

Wearing protective clothing will reduce your risk of injury. Long pants and eye protection reduce the risk of injuries from thrown objects. Sturdy shoes with aggressive soles provide better traction.

Turn the Engine Off When Not Operating the Tiller

If you need to leave the tiller for any reason, even just to inspect the area ahead, always turn the engine off.

Slope Operation

- When tilling on slopes, keep the fuel tank less than half full to minimize fuel spillage.
- Till across the slope (at equally spaced intervals) rather than up and down it.
- Be very careful when changing the direction of the tiller on a slope.
- Do not use the tiller on a slope of more than 10°. Before starting the engine, check that the tiller is not damaged and is in good condition. For your safety and the safety of others, exercise extreme care when using the tiller on a slope.

Tilling Conditions

Operate the tiller only in daylight or good artificial light. Do not operate the tiller at night or under poor light conditions.

TILLER SAFETY

SAFETY LABEL LOCATIONS

These labels warn you of potential hazards that can cause serious injury. Read them carefully. If a label comes off or becomes hard to read, contact your Honda servicing dealer for a replacement.

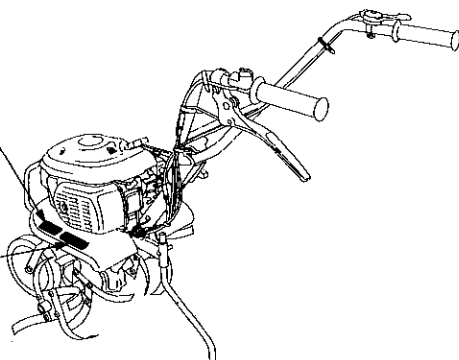
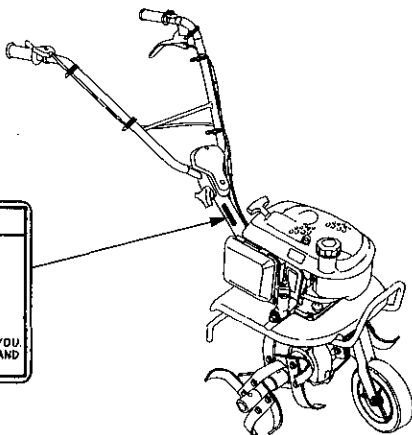
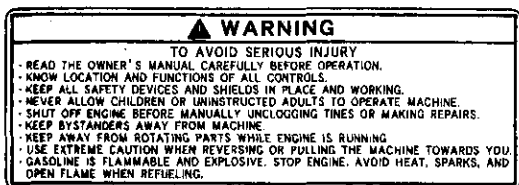

CONTROLS

COMPONENT & CONTROL LOCATIONS

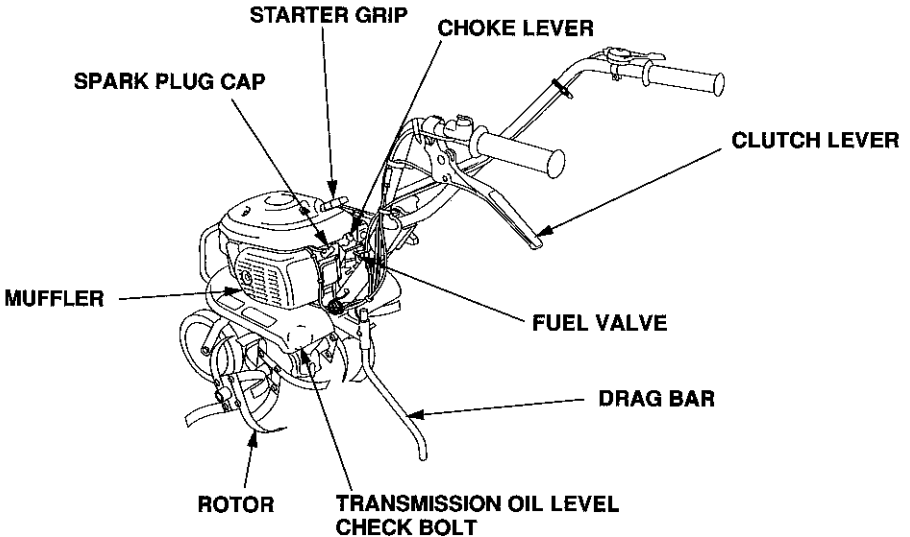
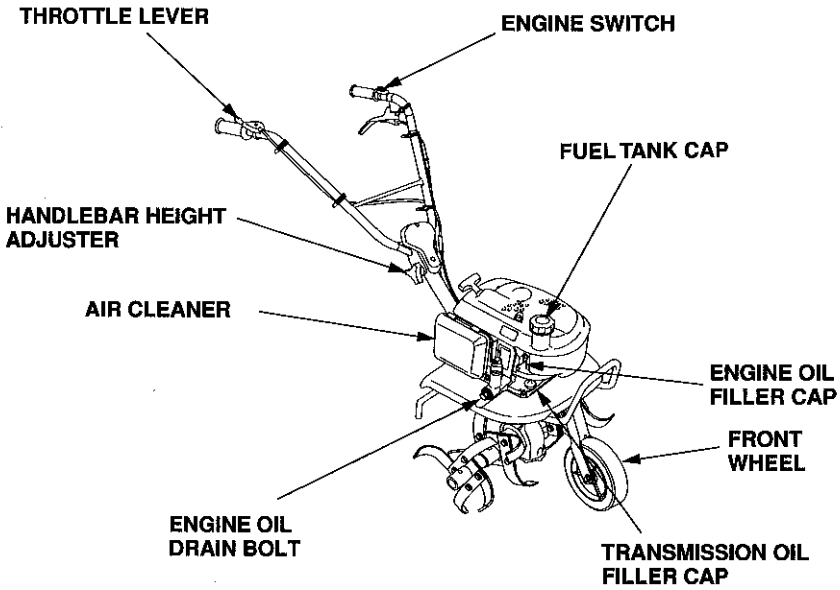

CONTROLS

CONTROLS

Fuel Valve

The fuel valve opens and closes the connection between the fuel tank and the carburetor.

The fuel valve must be in the ON position for the engine to run.

After stopping the engine, turn the fuel valve to the OFF position.

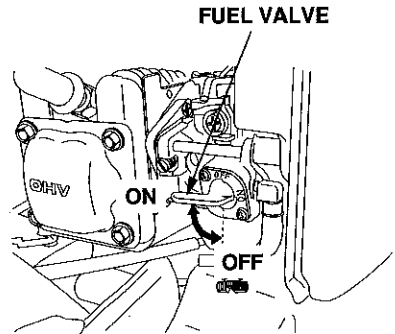

Choke Lever

The choke lever opens and closes the choke valve in the carburetor.

The CLOSED position enriches the fuel mixture for starting a cold engine.

The OPEN position provides the correct fuel mixture for operation after starting and for restarting a warm engine.

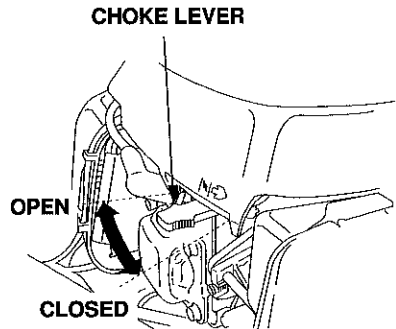

Engine Switch

The engine switch controls the ignition system.

OFF — Stops the engine.
ON — Running position.

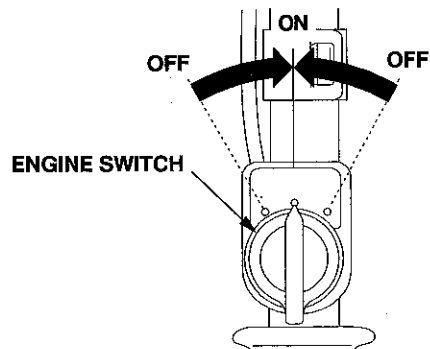

Starter Grip

Pulling the starter grip operates the recoil starter to crank the engine for starting.

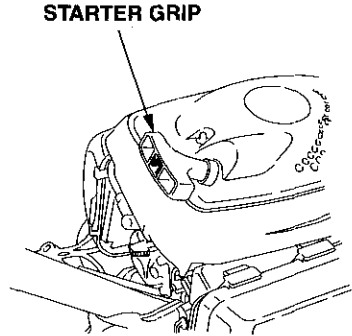

Throttle Lever

The throttle lever controls engine speed.

Moving the throttle lever in the directions shown makes the engine run faster or slower.

Tine speed is controlled by adjusting the throttle lever. At maximum throttle position, the tines will rotate at the highest speed.

Moving the throttle lever toward the idle position will decrease the tine speed.

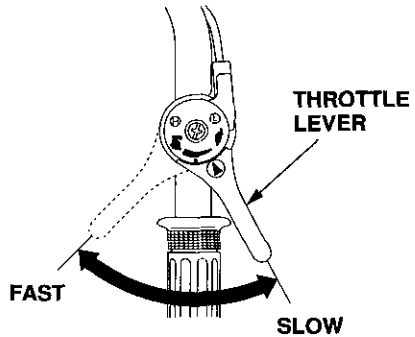

Handlebar Height Adjuster

Handlebar height can be adjusted to match operator height.

For normal tilling, the most comfortable operator position is with the handlebars at waist height.

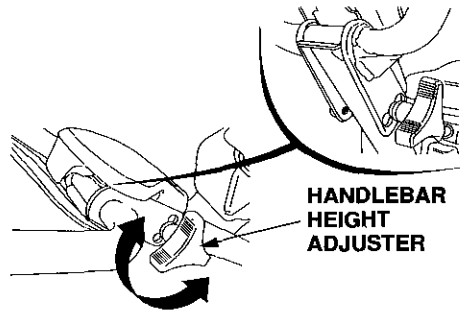

CONTROLS

Main Clutch Lever

The main clutch lever engages and disengages the transmission that drives the tines.

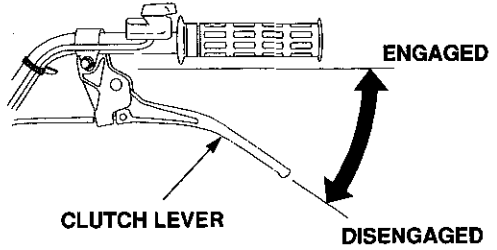

Drag Bar

The drag bar controls tilling depth and should always be used when tilling. It enables you to compensate for the hardness of the soil. Ideal drag bar height will depend on the type of soil being tilled and soil conditions at the time of tilling. In general, the drag bar should be adjusted so that the tiller is tilted slightly backward.

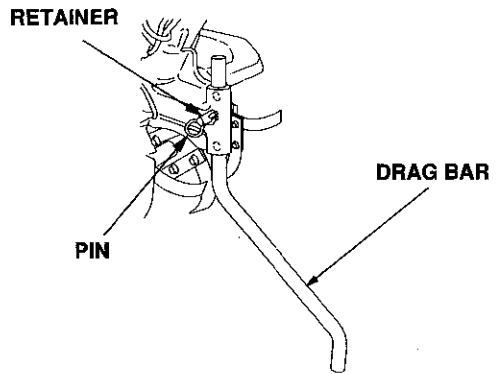

Front Wheel

The front wheel is used to help move the tiller from one place to another. Lift the tiller by the handlebars to roll the tiller on the front wheel. Return the wheel to the raised position before tilling. Always stop the engine before lowering or raising the wheel.

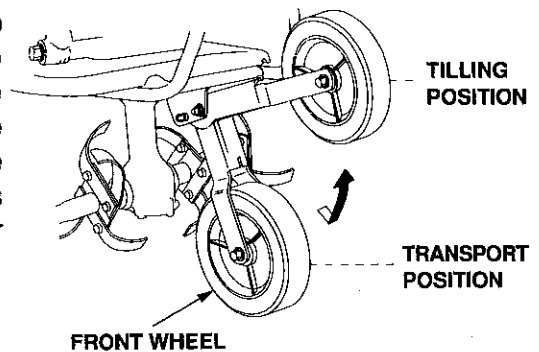

BEFORE OPERATION

ARE YOU READY TO GET STARTED?

Your safety is your responsibility. A little time spent in preparation will significantly reduce your risk of injury.

Knowledge

Read and understand this manual. Know what the controls do and how to operate them.

Familiarize yourself with the tiller and its operation before you begin using it. Know how to quickly shut off the tiller in case of an emergency.

IS YOUR TILLER READY TO GO?

For your safety, and to maximize the service life of your equipment, it is very important to take a few moments before you operate the tiller to check its condition. Be sure to take care of any problem you find, or have your servicing dealer correct it, before you operate the tiller.

WARNING

Improperly maintaining this tiller, or failing to correct a problem before operation, could cause a malfunction in which you could be seriously injured.

Always perform a pre-operation inspection before each operation, and correct any problem.

BEFORE OPERATION

Do not place flammable objects close to the engine.

Before beginning your pre-operation checks, be sure the tiller is on a level surface and the engine switch is in the OFF position.

Check the Engine

Check the oil level (see page 27).

Check the air filter (see page 31). A dirty air filter will restrict air flow to the carburetor, reducing engine and tiller performance.

Check the fuel level (see page 25). Starting with a full tank will help to eliminate or reduce operating interruptions for refueling.

Check the Tiller

Check the transmission oil (see page 30).

OPERATION

SAFE OPERATING PRECAUTIONS

Before operating the tiller for the first time, please review both the *TILLER SAFETY* chapter and the chapter titled *BEFORE OPERATION*.

For your safety, avoid starting or operating the tiller in an enclosed area such as a garage. Your tiller's exhaust contains poisonous carbon monoxide gas that can collect rapidly in an enclosed area and cause illness or death.

WARNING

Carbon monoxide gas is toxic. Breathing it can cause unconsciousness and even kill you.

Avoid any enclosed areas or activities that expose you to carbon monoxide.

OPERATION

STARTING THE ENGINE

Refer to *Safe Operating Precautions* on page 15.

⚠ WARNING

Tines are sharp and spin fast.

Spinning tines can cut you severely and can amputate body parts.

- Wear protective footwear.
- Keep your hands and feet away from the tines while the engine is running.
- Stop the engine before performing any adjustment, inspection, or maintenance.

1. Turn the fuel valve to the ON position. Check that the fuel drain screw is tightened securely.

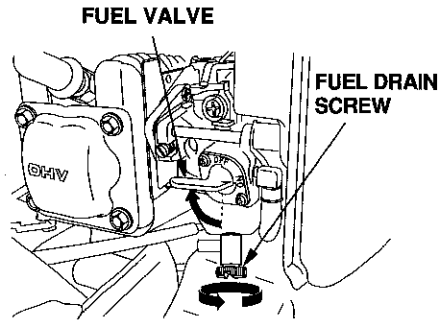

CHOKE LEVER

2. Move the choke lever to the CLOSED position to start a cold engine.

Leave the choke lever in the OPEN position to restart a warm engine.

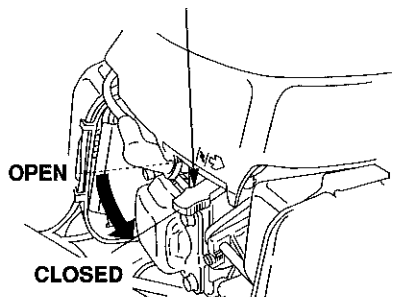

3. Turn the engine switch to the ON position

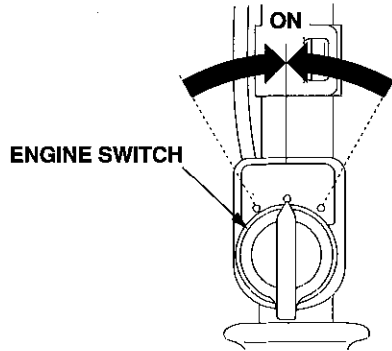

4. Move the throttle lever away from the SLOW position, about 1/3 of the way toward the FAST position.

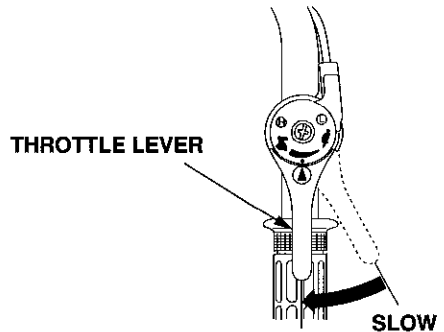

5. Pull the starter grip lightly until you feel resistance, then pull briskly in the direction of the arrow as shown.

NOTICE

Do not allow the starter grip to snap back against the engine. Return it gently to prevent damage to the starter.

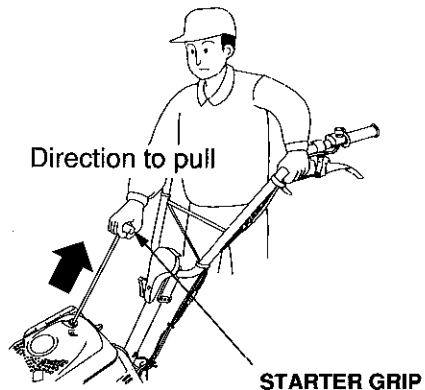

OPERATION

6. If the choke lever was moved to the CLOSED position to start the engine, gradually move it to the OPEN position as the engine warms up.

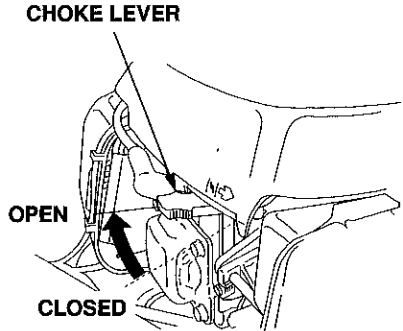

OPERATING THE CONTROLS FOR TILLING

If the tines dig in but the machine will not move forward, move the handlebars from side-to-side. When turning, push down on the handlebars to bring the tiller's weight to the rear; this will make turning easier.

Handlebar Height Adjustment

Stop the engine before adjusting the handlebar height.

To adjust the handlebar height, loosen the handlebar height adjuster, select the appropriate holes and tighten it.

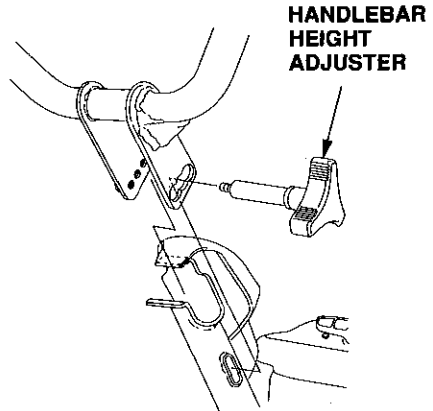

Clutch

When the main clutch lever is squeezed, the clutch is engaged, and power is transmitted to the transmission.

When the lever is released, the clutch is disengaged, and power is not transmitted.

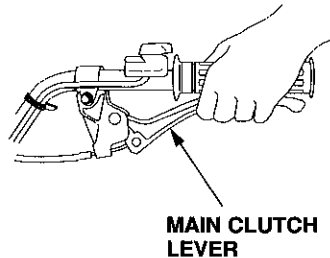

OPERATION

Tiling Depth Adjustment

The drag bar is used to control the tilling depth, which can be adjusted by removing the pin and retainer and sliding the drag bar up and down as necessary.

During operation, if the machine jerks forward while tilling, press down on the handlebars. This will cause the drag bar to dig more deeply into the soil.

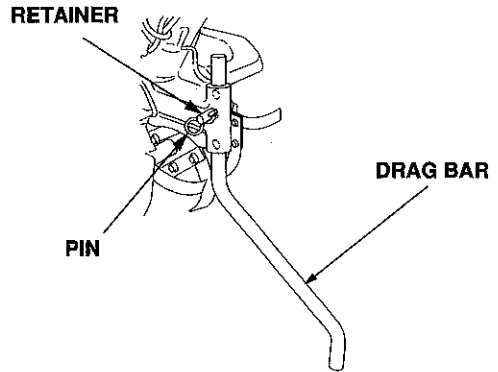

Front Wheel

After getting to the tilling site, move the front wheel to the raised position before tilling. Always stop the engine before lowering or raising the wheel.

To raise or lower the wheel, pull out the wheel assembly, move the wheel, then release the wheel assembly.

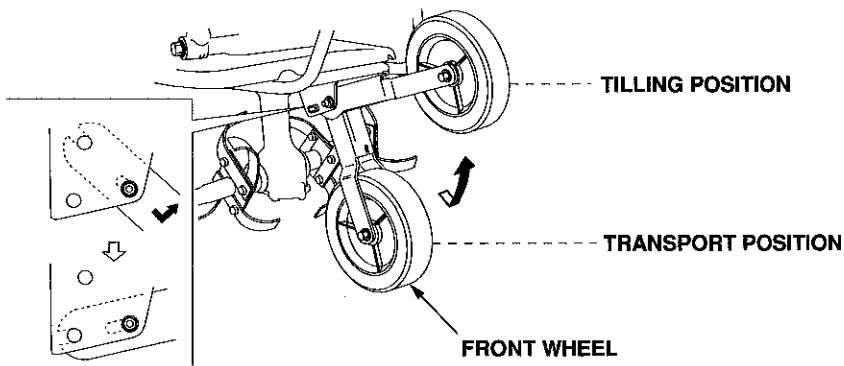

STOPPING THE ENGINE

To stop the engine in an emergency, simply turn the engine switch to the OFF position. Under normal conditions, use the following procedure.

1. Release the main clutch lever to the DISENGAGED position.

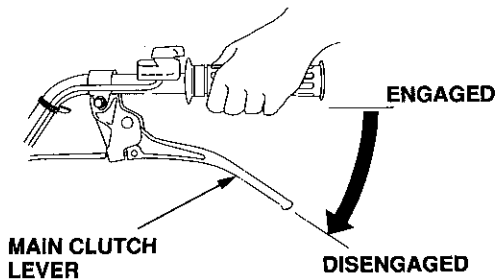

2. Move the throttle lever to the slowest position.

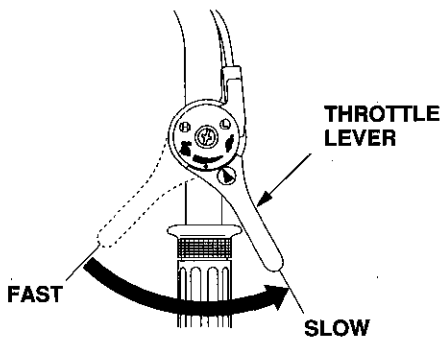

3. Turn the engine switch to the OFF position.

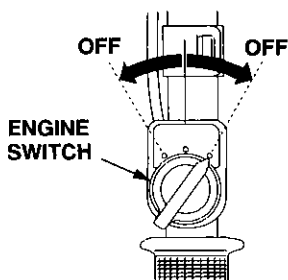

4. Turn the fuel valve to the OFF position.

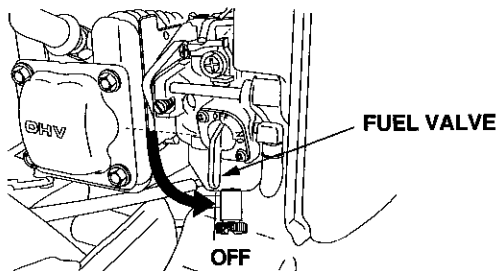

SERVICING YOUR TILLER

THE IMPORTANCE OF MAINTENANCE

Good maintenance is essential for safe, economical, and trouble-free operation. It will also help reduce air pollution.

To help you properly care for your tiller, the following pages include a maintenance schedule, routine inspection procedures, and simple maintenance procedures using basic hand tools. Other service tasks that are more difficult, or require special tools, are best handled by professionals and are normally performed by a Honda technician or other qualified mechanic.

The maintenance schedule applies to normal operating conditions. If you operate your tiller under unusual conditions (such as sustained high-load or high-temperature operation, or use in dusty conditions), consult your servicing dealer for recommendations applicable to your individual needs and use.

WARNING

Improper maintenance, or failure to correct a problem before operation, can cause a malfunction in which you can be seriously hurt or killed.

Always follow the inspection and maintenance recommendations and schedules in this owner's manual.

Remember that your servicing dealer knows your tiller best and is fully equipped to maintain and repair it.

To ensure the best quality and reliability, use only new, genuine Honda parts or their equivalents for repair and replacement.

Maintenance, replacement, or repair of the emission control devices and systems may be performed by any engine repair establishment or individual, using parts that are "certified" to EPA standards.

MAINTENANCE SAFETY

Some of the most important safety precautions follow. However, we cannot warn you of every conceivable hazard that can arise in performing maintenance. Only you can decide whether or not you should perform a given task.

WARNING

Failure to properly follow maintenance instructions and precautions can cause you to be seriously hurt or killed.

Always follow the procedures and precautions in the owner's manual.

Safety Precautions

- Make sure the engine is off before you begin any maintenance or repairs. This will eliminate several potential hazards:
 - **Carbon monoxide poisoning from engine exhaust.**
Be sure there is adequate ventilation whenever you operate the engine.
 - **Burns from hot parts.**
Let the engine and exhaust system cool before touching.
 - **Injury from moving parts.**
Do not run the engine unless instructed to do so.
- Read the instructions before you begin, and make sure you have the tools and skills required.
- To reduce the possibility of fire or explosion, be careful when working around gasoline. Use only a nonflammable solvent, not gasoline, to clean parts. Keep cigarettes, sparks, and flames away from all fuel-related parts.
- Disconnect the spark plug cap and wear heavy gloves when working near the tine blades.

SERVICING YOUR TILLER

MAINTENANCE SCHEDULE

ITEM	REGULAR SERVICE PERIOD (2) Perform at every indicated month or operating hour interval, whichever comes first.	Before season	Each use	First month or 20 hrs.	Every 3 months or 50 hrs.	Every 6 months or 100 hrs.	Every year or 300 hrs.
Engine oil	Check level		○				
	Change	○		○		○(4)	
Air filter	Check		○				
	Clean				○(1)		
	Replace						○
Tiller exterior	Check		○				
Lever function	Check		○				
Engine operation	Check		○				
Wiring and cables	Check		○				
Bolts and nuts	Check-tightness		○				
Transmission oil	Check	○(5)					
Spark plug	Check-adjust					○	
	Replace						○
Spark arrester (optional part)	Clean					○	
Clutch shoes	Check						○(3)
Clutch cable	Check-adjust			○		○	
Throttle cable	Check-adjust						○
Fuel tank (fuel filter)	Clean	○					○(3)
Valve clearance	Check-adjust						○(3)
Combustion chamber	Clean	After every 300 hrs (3)					
Fuel tube	Check	Every 2 years (Replace if necessary) (3)					

- (1) Service more frequently when used in dusty areas.
- (2) Log hours of operation to determine proper maintenance intervals.
- (3) These items should be serviced by your Honda servicing dealer, unless you have the proper tools and are mechanically proficient. Refer to Honda shop manual for service procedures.
- (4) Change engine oil every 50 hours when used under heavy load or in high ambient temperatures.
- (5) Exchange it in the purchase dealer or the service dealer when dirt is cruel.

Failure to follow this maintenance schedule could result in non-warrantable failures.

SERVICING YOUR TILLER

REFUELING

Remove the fuel tank cap and check the fuel level with the tiller on a level surface.

If the fuel level is low, refuel in a well-ventilated area with the engine stopped. If the engine has been running, allow it to cool first. Never refuel the engine inside a building where gasoline fumes can reach flames or sparks. Do not fill above the upper limit line.

▲ WARNING

Gasoline is highly flammable and explosive. You can be burned or seriously injured when handling fuel.

- Stop the engine and keep heat, sparks, and flame away.
- Refuel only outdoors.
- Wipe up spills immediately.

NOTICE

Fuel can damage paint and plastic. Be careful not to spill fuel when filling your fuel tank. Damage caused by spilled fuel is not covered under warranty.

FUEL TANK CAP

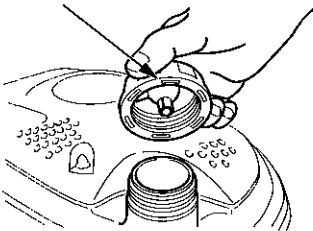

FUEL TANK

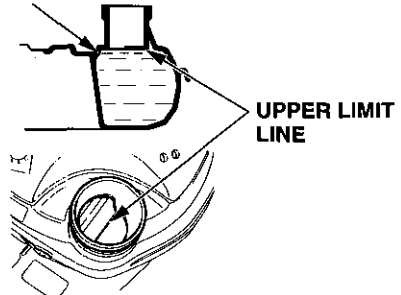

After refueling, reinstall the fuel tank cap securely.

Spilled fuel is not only a fire hazard, it causes environmental damage. Wipe up spills immediately.

SERVICING YOUR TILLER

FUEL RECOMMENDATIONS

This engine is certified to operate on unleaded gasoline with a pump octane rating of 86 or higher.

You may use regular unleaded gasoline containing no more than 10% Ethanol (E10) or 5% Methanol by volume. In addition, Methanol must contain cosolvents and corrosion inhibitors.

Use of fuels with content of Ethanol or Methanol greater than shown above may cause starting and/or performance problems. It may also damage metal, rubber, and plastic parts of the fuel system.

Engine damage or performance problems that result from using a fuel with percentages of Ethanol or Methanol greater than shown above are not covered under warranty.

Never use stale or contaminated gasoline or an oil/gasoline mixture. Avoid getting dirt or water in the fuel tank.

SERVICING YOUR TILLER

ENGINE OIL LEVEL CHECK

Check the engine oil level with the tiller on a level surface and the engine stopped.

1. Remove the oil filler cap. Check that the oil level is at the upper limit of the oil level gauge.
2. If the oil level is low, fill to the upper limit of the level gauge with the recommended oil (see page 29).
3. Screw in the oil filler cap securely.

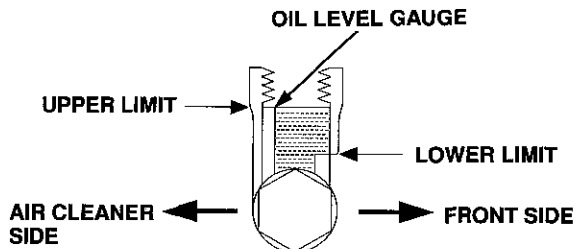
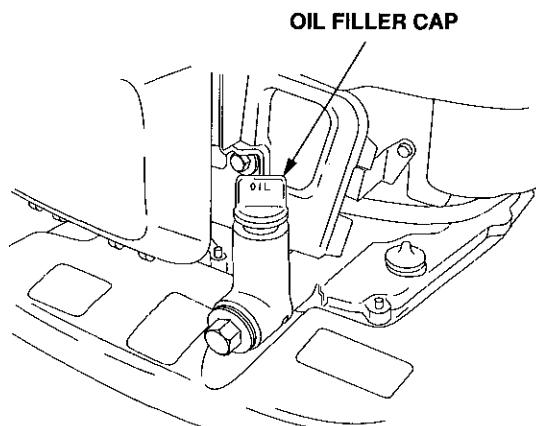

SERVICING YOUR TILLER

ENGINE OIL CHANGE

Drain the oil while the engine is warm to assure rapid and complete draining.

1. Place a suitable container below the engine to catch the used oil, then remove the filler cap, drain plug and sealing washer.
2. Allow the used oil to drain completely, then reinstall the drain plug with a new sealing washer. Tighten the plug securely.

NOTICE

Improper disposal of engine oil can be harmful to the environment. If you change your own oil, please dispose of the used oil properly. Put it in a sealed container and take it to a recycling center. Do not throw it in the trash, pour it on the ground, or pour it down a drain.

3. With the tiller in a level position, fill with the recommended oil to the upper limit of the level gauge (see page 29).

NOTICE

Running the engine with a low oil level can cause engine damage. This type of damage is not covered under the Distributor's Limited Warranty.

4. Screw in the filler cap securely.

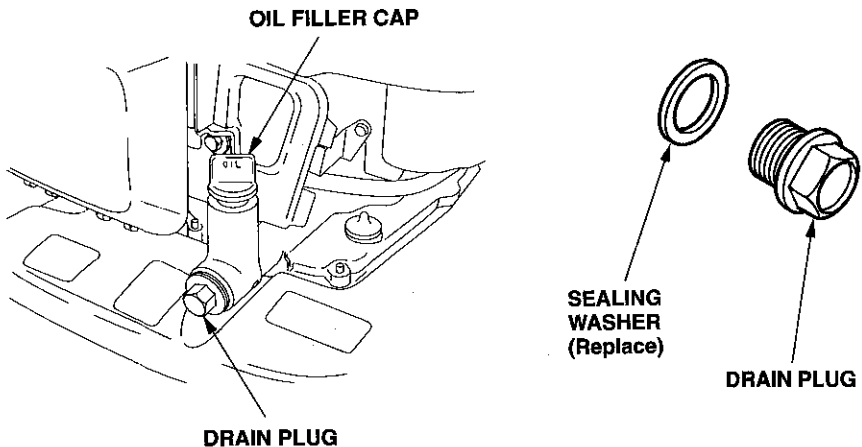

SERVICING YOUR TILLER

ENGINE OIL RECOMMENDATIONS

Oil is a major factor affecting performance and service life. Use 4-stroke automotive detergent oil.

SAE 10W-30 is recommended for general use. Other viscosities shown in the chart may be used when the average temperature in your area is within the recommended range.

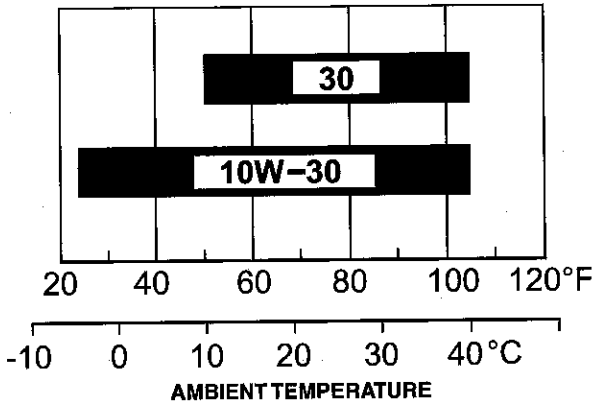

The SAE oil viscosity and service category are in the API label on the oil container. Honda recommends that you use API SERVICE category SJ or later (or equivalent) oil.

SERVICING YOUR TILLER

TRANSMISSION OIL LEVEL CHECK

Check the transmission oil level with the tiller on a level surface and the engine stopped.

1. Remove the transmission oil level check bolt. The oil should be level with the lower edge of the oil filler hole.
2. Remove the transmission oil filler cap and add the same oil as recommended for the engine (see page 29), if the level is low.
3. Reinstall the oil filler cap and tighten the oil level check bolt securely.

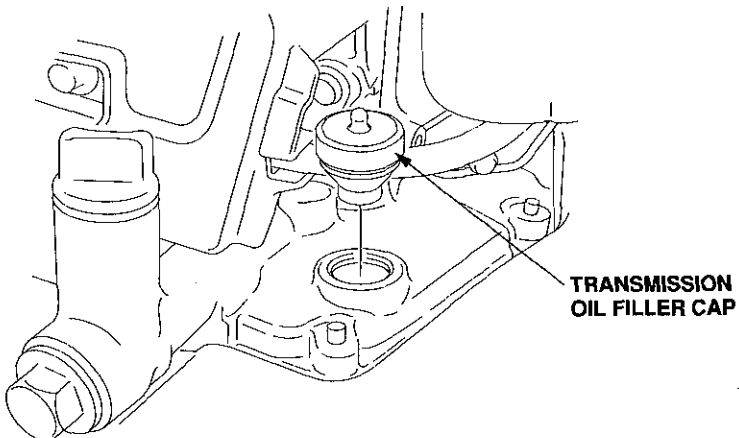
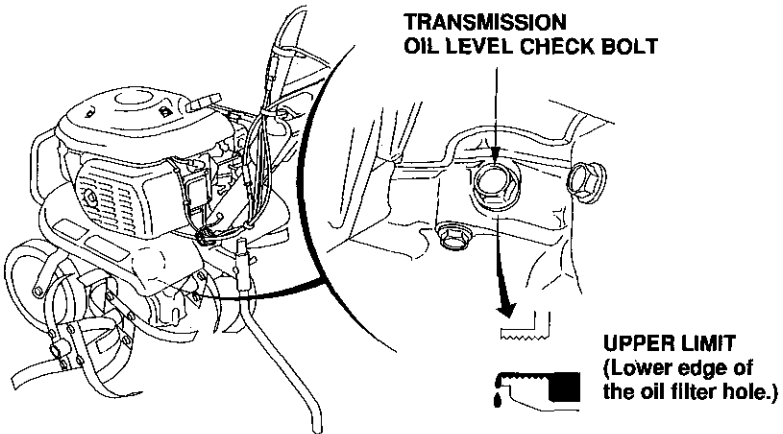

SERVICING YOUR TILLER

AIR FILTER INSPECTION

Press the latch tabs on the fuel tank side of the air cleaner cover, remove the air cleaner cover, and remove the filter.

Check the filter to be sure it is clean and in good condition. If the filter is dirty, remove the filter and clean it as described on page 32. Replace the filter if it is damaged.

Reinstall the filter and air cleaner cover. Make sure the latch tabs are secured.

NOTICE

Operating the engine without an air filter, or with a damaged air filter, will allow dirt to enter the engine, causing rapid engine wear. This type of damage is not covered by the Distributor's Limited Warranty.

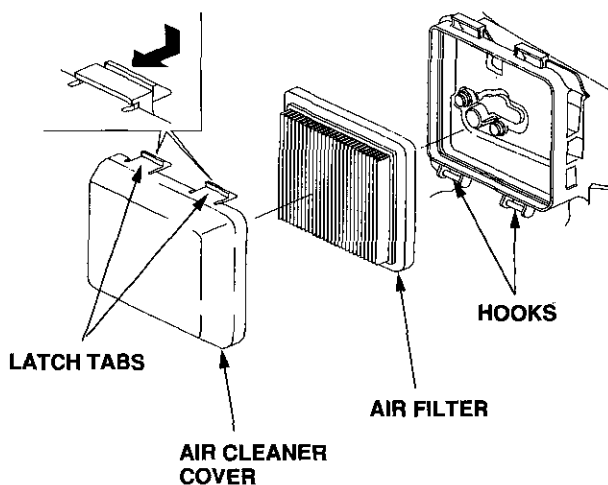

SERVICING YOUR TILLER

AIR FILTER CLEANING

A dirty air filter will restrict air flow to the carburetor, reducing engine performance. If you operate the generator in very dusty areas, clean the air filter more frequently than specified in the *Maintenance Schedule*.

1. Tap the air filter element several times on a hard surface to remove dirt, or blow compressed air [not exceeding 207 kPa (2.1 kgf/cm², 30 psi)] through the air filter from the air cleaner housing side. Never try to brush off dirt; brushing will force dirt into the fibers. Replace the air filter if it is excessively dirty.
2. Wipe dirt from the air cleaner housing and cover using a moist rag. Be careful to prevent dirt from entering the air duct that leads to the carburetor.

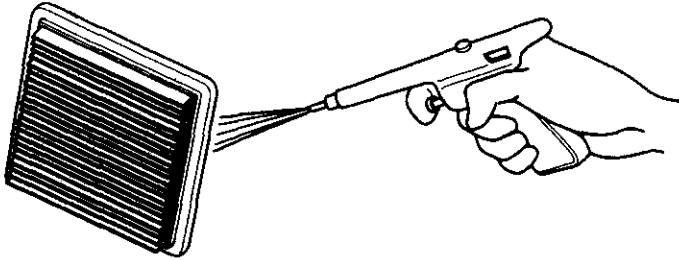

SPARK PLUG SERVICE

Recommended spark plugs: CR4HSB (NGK)
U14FSR-UB (DENSO)

NOTICE

Incorrect spark plugs can cause engine damage.

1. Disconnect the spark plug cap, and remove any dirt from around the spark plug area.
2. Remove the spark plug with a 5/8-inch spark plug wrench.

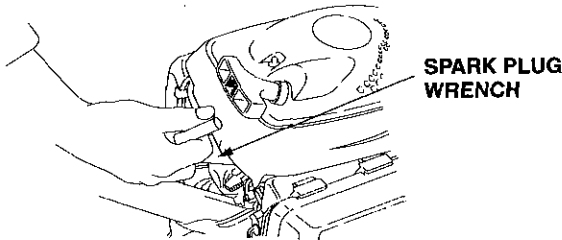

3. Inspect the spark plug. Replace it if the electrodes are worn, or if the insulator is cracked, chipped, or fouled.
4. Measure the spark plug electrode gap with a wire-type feeler gauge. The gap should be 0.024 – 0.028 in (0.60 – 0.70 mm). Correct the gap, if necessary, by carefully bending the side electrode.
5. Install the spark plug carefully, by hand, to avoid cross-threading.
6. After the spark plug seats, tighten with a 5/8-inch spark plug wrench to compress the washer.

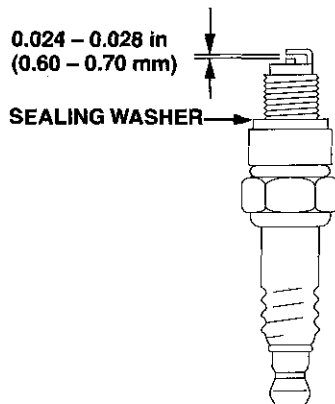

SERVICING YOUR TILLER

If reinstalling a used spark plug, tighten $1/8 - 1/4$ turn after the spark plug seats.

If installing a new spark plug, tighten $1/2$ turn after the spark plug seats.

NOTICE

A loose spark plug can overheat and damage the engine.

Overtightening the spark plug can damage the threads in the cylinder head.

7. Attach the spark plug cap.

CLUTCH CABLE ADJUSTMENT

1. Set the handlebar height in the center position (see page 19).
2. The clutch spring should extend 0.08 ± 0.02 in (2.0 ± 0.5 mm) when the main clutch lever is moved from the DISENGAGED position to the ENGAGED position.
3. If the spring extension length is incorrect, loosen the lock nut and turn the adjusting nut in or out just enough to extend the spring. Do not overtighten. After adjustment, tighten the lock nut.

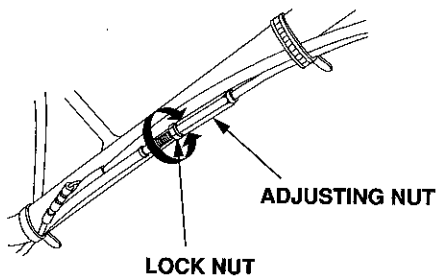

CLUTCH SPRING END

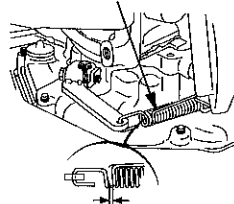

0.08 ± 0.02 in
(2.0 ± 0.5 mm)

THROTTLE CABLE ADJUSTMENT

Measure the free play at the lever tip.

Free play: $0.39 - 0.59$ in ($10.0 - 15.0$ mm)

If the free play is incorrect, loosen the lock nut and turn the adjusting nut in or out as required.

After adjustment, tighten the lock nut.

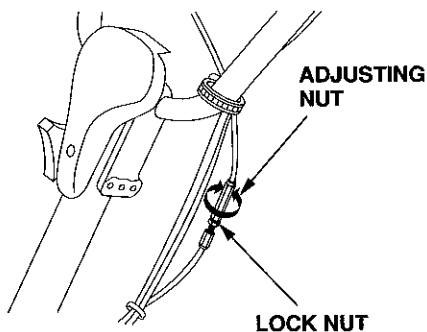
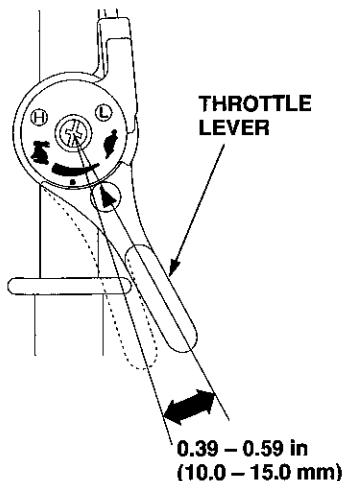

SERVICING YOUR TILLER

SPARK ARRESTER SERVICE (optional equipment)

Your engine is not factory-equipped with a spark arrester. In some areas, it is illegal to operate an engine without a spark arrester. Check local laws and regulations. A spark arrester is available from Honda servicing dealers.

The spark arrester must be serviced every 100 hours to keep it functioning as designed.

If the engine has been running, the muffler will be very hot. Allow the muffler to cool before servicing the spark arrester.

1. Remove the three 5 mm bolts from the muffler protector, and remove the muffler protector.

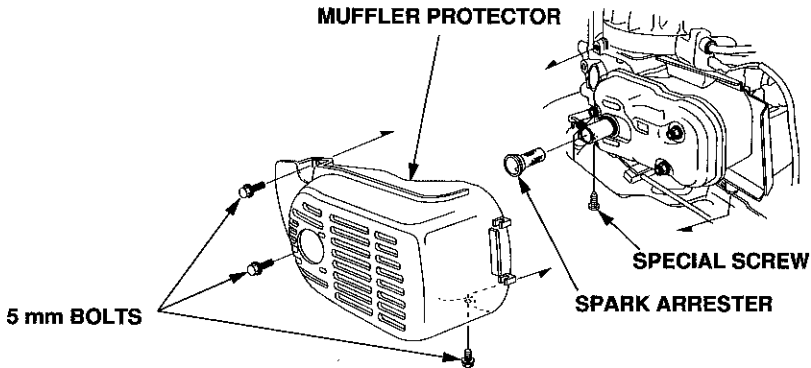

2. Remove the special screw from the spark arrester, and remove the spark arrester from the muffler.
3. Use a brush to remove carbon deposits from the spark arrester screen. Be careful to avoid damaging the screen. The spark arrester must be free of breaks and holes. Replace the spark arrester if it is damaged.

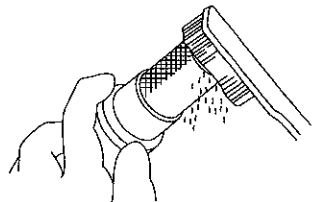

4. Install the spark arrester and muffler protector, in the reverse order of disassembly.

STORAGE

STORAGE PREPARATION

Proper storage preparation is essential for keeping your tiller trouble free and looking good. The following steps will help to keep rust and corrosion from impairing your tiller's function and appearance, and will make the engine easier to start when you use the tiller again.

Cleaning

1. Wash the tiller, including the underside.

Engine

Wash the engine by hand, and be careful to prevent water from entering the air cleaner.

NOTICE

- *Using a garden hose or pressure washing equipment can force water into the air cleaner. Water in the air cleaner will soak the filter element and can enter the carburetor or engine cylinder, causing damage.*
- *Water contacting a hot engine can cause damage. If the engine has been running, allow it to cool for at least half an hour before washing.*

Tiller

If using a garden hose or pressure washing equipment to clean the tiller, be careful to avoid getting water on the belts.

NOTICE

Spraying water on hot tine shaft bearings can cause them to be damaged from cooling too quickly.

STORAGE

2. After washing the tiller, wipe dry all accessible surfaces.
3. Start the engine outdoors, and let it run until it reaches normal operating temperature to evaporate any water remaining on the engine.
4. While the engine is running, operate the clutch lever to expel water from the pulleys, belts, and other moving items.
5. Stop the engine and allow it to cool.
6. After the tiller is clean and dry, touch up any damaged paint and coat other areas with a light film of oil. Lubricate the throttle cable core with a silicone spray lubricant.

Fuel

Gasoline will oxidize and deteriorate in storage. Old gasoline will cause hard starting, and it leaves gum deposits that clog the fuel system. If the gasoline in your tiller deteriorates during storage, you may need to have the carburetor and other fuel system components serviced or replaced.

The length of time that gasoline can be left in your fuel tank and carburetor without causing functional problems will vary with such factors as gasoline blend, your storage temperatures, and whether the fuel tank is partially or completely filled. The air in a partially filled fuel tank promotes fuel deterioration. Very warm storage temperatures accelerate fuel deterioration. Fuel deterioration problems may occur within a few months, or even less if the gasoline was not fresh when you filled the fuel tank.

The *Distributor's Limited Warranty* does not cover fuel system damage or engine performance problems resulting from neglected storage preparation.

You can extend fuel storage life by adding a gasoline stabilizer that is formulated for that purpose, or you can avoid fuel deterioration problems by draining the fuel tank and carburetor.

Adding a Gasoline Stabilizer to Extend Fuel Storage Life

When adding a gasoline stabilizer, fill the fuel tank with fresh gasoline. If only partially filled, air in the tank will promote fuel deterioration during storage. If you keep a container of gasoline for refueling, be sure that it contains only fresh gasoline.

1. Add gasoline stabilizer following manufacturer's instructions.
2. After adding a gasoline stabilizer, run the engine outdoors for 10 minutes to be sure that treated gasoline has replaced the untreated gasoline in the carburetor.
3. Stop the engine, and turn the fuel valve to the OFF position.

STORAGE

Draining the Fuel Tank and Carburetor

1. Place an approved gasoline container below the carburetor, and use a funnel to avoid spilling fuel.
2. Loosen the carburetor drain screw, then move the fuel valve to the ON position.

⚠ WARNING

Gasoline is highly flammable and explosive.

You can be burned or seriously injured.

Never use gasoline to clean engine parts.
Use a nonflammable solvent.

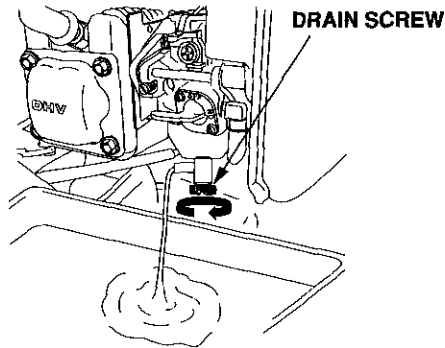

3. After all the fuel has drained into the container, tighten the drain screw securely.

Engine Oil

1. Change the engine oil (see page 28).
2. Remove the spark plug (see page 33).
3. Pour a teaspoon (5 – 10 cm³) of clean engine oil into the cylinder.
4. Gently pull the starter grip several times to distribute the oil in the cylinder.
5. Reinstall the spark plug.
6. Pull the starter grip slowly until you feel resistance, then return the starter grip gently. This will close the valves so moisture cannot enter the engine cylinder.

STORAGE

STORAGE PRECAUTIONS

If your tiller will be stored with gasoline in the fuel tank and carburetor, it is important to reduce the hazard of gasoline vapor ignition. Select a well ventilated storage area away from any appliance that operates with a flame, such as a furnace, water heater, or clothes dryer. Also avoid any area with a spark-producing electric motor, or where power tools are operated.

If possible, avoid storage areas with high humidity, because that promotes rust and corrosion.

Unless all fuel has been drained from the fuel tank, leave the fuel valve in the OFF position to reduce the possibility of fuel leakage.

Place the tiller on a level surface. Tilting can cause fuel or oil leakage.

With the engine and exhaust system cool, cover the tiller to keep out dust. A hot engine and exhaust system can ignite or melt some materials. Do not use sheet plastic as a dust cover. A nonporous cover will trap moisture around the tiller, promoting rust and corrosion.

REMOVAL FROM STORAGE

Check your tiller as described in the *BEFORE OPERATION* chapter of this manual.

If the fuel was drained during storage preparation, fill the tank with fresh gasoline. If you keep a container of gasoline for refueling, be sure that it contains only fresh gasoline. Gasoline oxidizes and deteriorates over time, causing hard starting.

If the cylinder was coated with oil during storage preparation, the engine may smoke briefly at start-up. This is normal.

TRANSPORTING

BEFORE LOADING

If the engine has been running, allow it to cool for at least 15 minutes before loading the tiller on the transport vehicle. A hot engine and exhaust system can burn you and can ignite some materials.

Always turn the ignition switch to the OFF position. Make sure to turn the fuel valve OFF.

LOADING AND UNLOADING

If a suitable loading ramp is not available, two people should lift the tiller on and off the transport vehicle while holding the tiller level.

Position the tiller so it sits flat on the bed of the transport vehicle. Tie the tiller down with rope or straps. Keep the tie-down rope or straps away from the controls, adjustment levers, cables, and the carburetor.

The handlebar can be folded either front or back so the tiller will take up less space (see page 19).

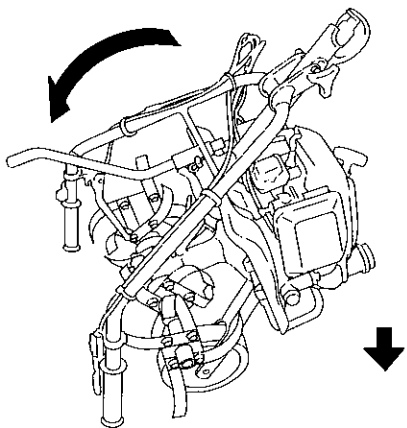

Fold to the back side.

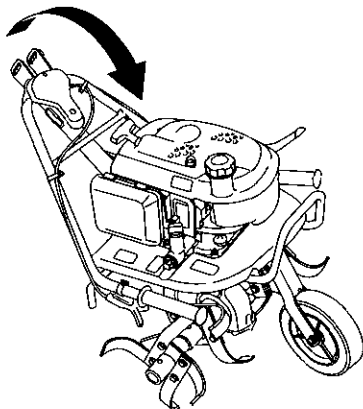

Fold to the front side.

TAKING CARE OF UNEXPECTED PROBLEMS

ENGINE PROBLEMS

Engine Will Not Start	Possible Cause	Correction
1. Check control positions.	Fuel valve OFF.	Turn valve ON.
	Choke OPEN.	Move to CLOSED unless engine is warm.
	Engine switch OFF.	Turn engine switch to ON.
2. Check fuel.	Out of fuel.	Refuel (p. 25).
	Bad fuel; tiller stored without treating or draining gasoline, or refueled with bad gasoline.	Drain fuel tank and carburetor (p. 40). Refuel with fresh gasoline (p. 25).
3. Remove and inspect spark plug.	Spark plug faulty, fouled, or improperly gapped.	Clean, gap, or replace spark plug (p. 33).
	Spark plug wet with fuel (flooded engine).	Dry and reinstall spark plug. Start engine with throttle lever in FAST position.
4. Take tiller to an authorized Honda servicing dealer, or refer to the shop manual.	Fuel filter clogged, carburetor malfunction, ignition malfunction, valves stuck, etc.	Replace or repair faulty components as necessary.

TAKING CARE OF UNEXPECTED PROBLEMS

Engine Lacks Power	Possible Cause	Correction
1. Check air filter.	Air filter clogged.	Clean or replace air filter (p. 32).
2. Check fuel.	Bad fuel; tiller stored without treating or draining gasoline, or refueled with bad gasoline.	Drain fuel tank and carburetor (p. 40). Refuel with fresh gasoline (p. 25).
3. Take tiller to an authorized Honda servicing dealer, or refer to the shop manual.	Fuel filter clogged, carburetor malfunction, ignition malfunction, valves struck, etc.	Replace or repair faulty components as necessary.

TAKING CARE OF UNEXPECTED PROBLEMS

TILLING PROBLEMS

Poor Tilling Quality	Possible Cause	Correction
1. Check that the throttle lever is in the FAST position.	Engine speed is too slow for soil conditions.	Move the throttle to the FAST position (p.11).
2. Reduce forward speed.	Tiller is moving too fast for soil conditions.	Reduce throttle speed (p. 11).
3. Check drag bar depth setting.	Drag bar adjustment set too high.	Lower drag bar adjustment (p. 20).
4. Check tines.	Tines dull, worn, or damaged.	Replace tines if necessary.
	Wrong tines installed.	Install correct tines.
	Tines installed incorrectly.	Install tines correctly.

TECHNICAL & CONSUMER INFORMATION

TECHNICAL INFORMATION

Serial Number Locations

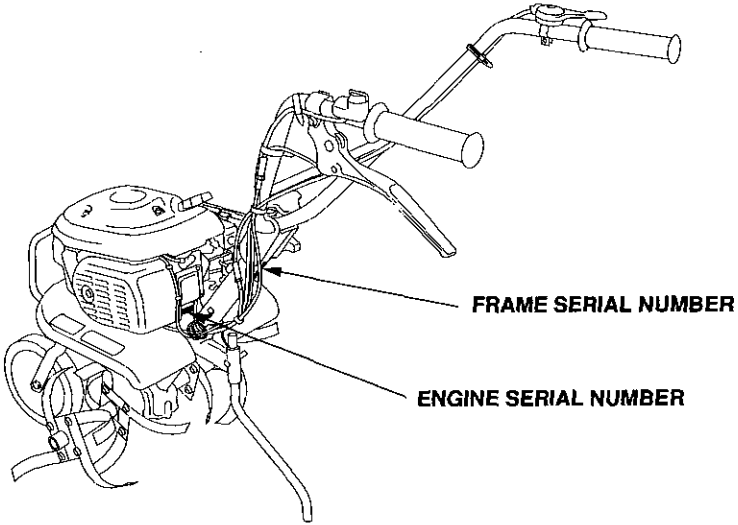

Record the engine and frame serial numbers in the spaces below. You will need these serial numbers when ordering parts, and when making technical or warranty inquiries (see page 53).

Engine serial number: _____

Frame serial number: _____

Date purchased: _____

TECHNICAL & CONSUMER INFORMATION

Carburetor Modification for High Altitude Operation

At high altitude, the standard carburetor air-fuel mixture will be too rich. Performance will decrease, and fuel consumption will increase. A very rich mixture will also foul the spark plug and cause hard starting. Operation at an altitude that differs from that at which this engine was certified, for extended periods of time, may increase emissions.

High altitude performance can be improved by a specific modifications to the carburetor. If you always operate your tiller at altitudes above 5,000 feet (1,500 meters) have your servicing dealer perform this carburetor modification. This engine, when operated at high altitude with the carburetor modifications for high altitude use, will meet each emission standard throughout its useful life.

Even with carburetor modification, engine horsepower will decrease about 3.5% for each 1,000-foot (300-meter) increase in altitude. The effect of altitude on horsepower will be greater than this if no carburetor modification is made.

NOTICE

When the carburetor has been modified for high altitude operation, the air-fuel mixture will be too lean for low altitude use. Operation at altitudes below 5,000 feet (1,500 meters) with a modified carburetor may cause the engine to overheat and result in serious engine damage. For use at low altitudes, have your servicing dealer return the carburetor to original factory specification.

TECHNICAL & CONSUMER INFORMATION

Emission Control System Information

Source of Emissions

The combustion process produces carbon monoxide, oxides of nitrogen, and hydrocarbons. Control of hydrocarbons and oxides of nitrogen is very important because, under certain conditions, they react to form photochemical smog when subjected to sunlight. Carbon monoxide does not react in the same way, but it is toxic.

Honda utilizes appropriate air/fuel ratios and other emissions control systems to reduce the emissions of carbon monoxide, oxides of nitrogen and hydrocarbons.

The U.S. and California Clean Air Act

EPA and California regulations require all manufacturers to furnish written instruction describing the operation and maintenance of emission control systems.

The following instructions and procedures must be followed in order to keep the Honda engine emissions within the emission standards.

Tampering and Altering

Tampering with or altering the emission control system may increase emissions beyond the legal limit. Among those acts that constitute tampering are:

- Removal or alteration of any part of intake, fuel, or exhaust system.
- Altering or defeating the governor linkage or speed-adjusting mechanism to cause the engine to operate outside its design parameters.

TECHNICAL & CONSUMER INFORMATION

Problems That May Affect Emissions

If you are aware of any of the following symptoms, have your engine inspected and repaired by your authorized Honda servicing dealer.

- Hard starting or stalling after starting.
- Rough idle.
- Misfiring or backfiring under load.
- Afterburning (backfiring).
- Black exhaust smoke or high fuel consumption.

Replacement Parts

The emission control systems on your new Honda engine were designed, built, and certified to conform with EPA and California emission regulations. We recommend the use of genuine Honda parts whenever you have maintenance done. These original-design replacement parts are manufactured to the same standards as the original parts, so you can be confident of their performance. The use of replacement parts that are not of the original design and quality may impair the effectiveness of your emission control system.

A manufacturer of an aftermarket part assumes the responsibility that the part will not adversely affect emission performance. The manufacturer or rebuilder of the part must certify that use of the part will not result in a failure of the engine to comply with emission regulations.

Maintenance

Follow the *Maintenance Schedule* on page 24. Remember that this schedule is based on the assumption that your machine will be used for its designed purpose. Sustained high-load or high-temperature operation, or use in unusually wet or dusty conditions, will require more frequent service.

TECHNICAL & CONSUMER INFORMATION

Specifications

Model	F220
Type	Non - California type (AN type)
Description code	FAAJ
Dry mass [weight]	49.6 lbs (22.5 kg)
Length	47.2 in (1,200 mm)
Width	21.5 in (545 mm)
Height	38.4 in (975 mm)
Engine model	GXV57
Engine type	Single cylinder, 4-stroke, forced air cooled, overhead valve, gasoline
Displacement	3.5 cu-in (57.3 cm ³)
Bore x Stroke	1.77 x 1.41 in (45.0 x 36.0 mm)
Ignition system	Transistor magneto
Spark plug	CR4HSB (NGK), U14FSR-UB (DENSO)
Oil capacity	0.32 US qt (0.30 ℓ)
Fuel tank capacity	0.18 US gal (0.67ℓ)
Clutch	Shoe clutch
Transmission oil capacity	0.95 US qt (0.90 ℓ)

Tune-up Specifications

ITEM	SPECIFICATION	MAINTENANCE
Spark plug gap	0.024–0.028 in (0.60–0.70 mm)	Refer to page 33.
Valve clearance	IN:0.08 ± 0.02 mm (cold) EX:0.11 ± 0.02 mm (cold)	See your authorized Honda dealer.
Other specification	No other adjustments needed.	

NOTE: Specifications are subject to change without notice.

TECHNICAL & CONSUMER INFORMATION

CONSUMER INFORMATION

Dealer Locator Information

To find an authorized Honda Servicing Dealer anywhere in the United States:

Call (800) 426-7701 or visit our web site:
www.hondapowerequipment.com/dea.htm

Honda Publications

Shop Manual

This manual covers complete maintenance and overhaul procedures. It is intended to be used by a skilled technician.

Available through your Honda dealer or through Helm Inc. at 1 888-292-5395 or visit www.hondapowerequipment.com/own.htm

Parts Catalog

This manual provides complete, illustrated parts lists. Available through your Honda dealer.

Accessories Catalog

Your authorized Honda power equipment dealer offers a wide selection of accessories to make your tiller even more useful.

Visit www.hondapowerequipment.com/acc.htm and click on Tillers to see the entire catalog of accessories.

Customer Service Information

Servicing dealership personnel are highly trained professionals. They should be able to answer any question you may have. If you encounter a problem that your dealer does not solve to your satisfaction, please discuss it with the dealership's management. The Service Manager or General Manager can help. Almost all problems are solved in this way.

If you are dissatisfied with the decision made by the dealership's management, contact the Honda Power Equipment Customer Relations Office. You can write:

American Honda Motor Co., Inc.
Power Equipment Division
Customer Relations Office
4900 Marconi Drive
Alpharetta, Georgia 30005 – 8847

Or telephone: (770) 497 – 6400 8:30 am to 8:00 pm ET

When you write or call, please give us this information:

- Model and serial numbers (see page 47)
- Name of the dealer who sold the tiller to you
- Name and address of the dealer who services your tiller
- Date of purchase
- Your name, address, and telephone number
- A detailed description of the problem

QUICK REFERENCE INFORMATION

Fuel	Type	Unleaded gasoline with a pump octane rating of 86 or higher (see page 26)
Engine Oil	Type	SAE 10 W – 30, API SJ or later, for general use (page 29)
Spark Plug	Type	NGK: CR4HSB DENSO: U14FSR –UB
Maintenance	Before each use	Check engine oil level. Check air filter. Tiller exterior Each lever function Bolt and nut torque Cables and wires Engine operation Transmission oil
	First 20 hours	Change engine oil
	Subsequent	Refer to maintenance schedule (page 24)

HONDA

The Power of Dreams

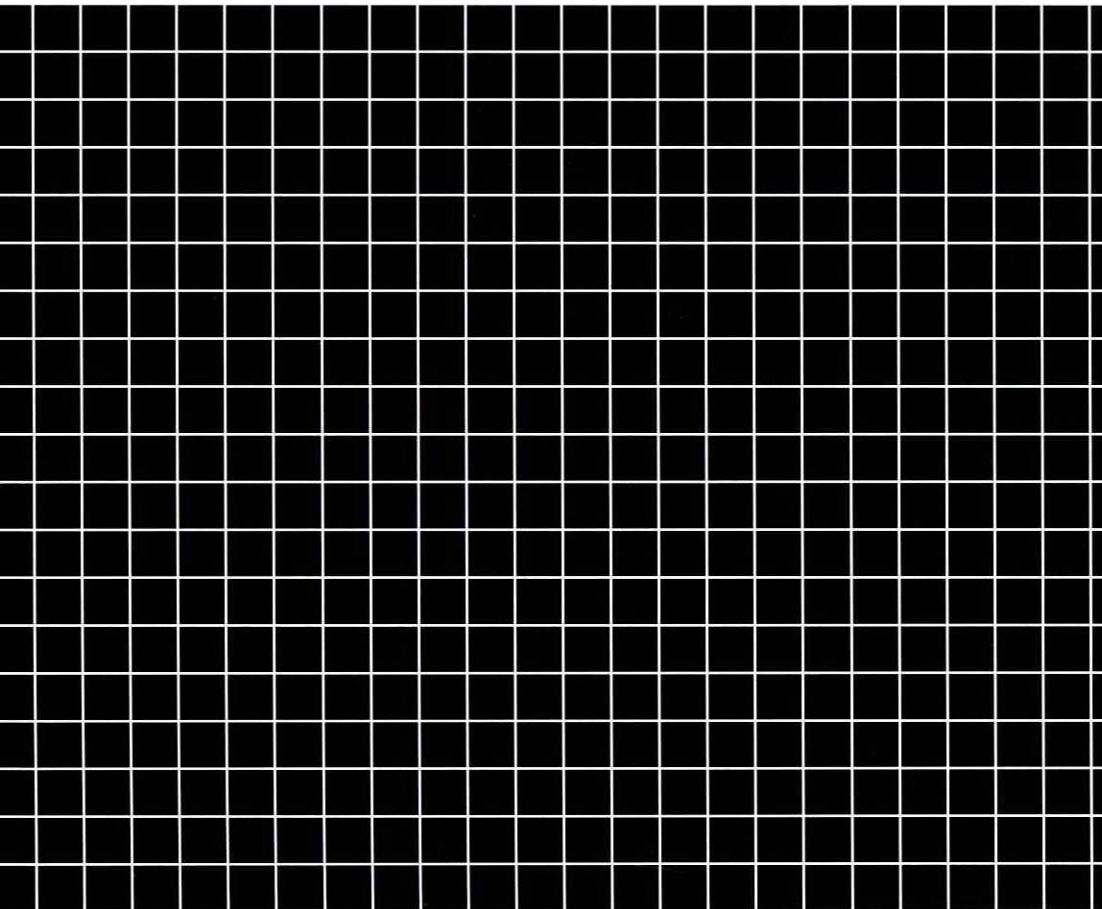

31V14611
00X31-V14-6110

EM3 (AH) (英) (V) 1000.2007.05
Printed in Japan