

HONDA
SNOWBLOWERS
HS55/HS70



OWNER'S MANUAL

Thank you for purchasing a Honda snowblower.

This manual covers the operation and maintenance of HS55/HS70 snowblowers.

All information in this publication is based on the latest product information available at the time of approval for printing.

Honda Motor Co., Ltd. reserves the right to make changes at any time without notice and without incurring any obligation.

No part of this publication may be reproduced without written permission.

This manual should be considered a permanent part of the snowblower and should remain with the snowblower if it is sold.

Illustrations herein are mainly based on HS55 model.

Pay special attention to statements preceded by the following words:

WARNING Indicates a strong possibility of severe personal injury or loss of life if instructions are not followed.

CAUTION: Indicates a possibility of personal injury or equipment damage if instructions are not followed.

NOTE: Gives helpful information.

If a problem should arise, or if you have any questions about the snowblower consult an authorized Honda dealer.

WARNING Honda snowblowers are designed to give safe and dependable service if operated according to instructions. Read and understand the Owner's Manual before operating the snowblower. Failure to do so could result in personal injury or equipment damage.

CONTENTS

1. SAFETY INSTRUCTIONS	3
2. WARNING LABEL LOCATION	5
3. COMPONENT IDENTIFICATION AND FUNCTION	6
ENGINE SWITCH	10
FUEL VALVE	10
CHOKE LEVER	11
STARTER GRIP	11
THROTTLE LEVER (ENGINE SPEED)	12
SHIFT LEVER	12
AUGER CLUTCH LEVER AND DRIVE CLUTCH LEVER	13
CHUTE CRANK	14
CHUTE GUIDE	14
SKID PLATE	15
HEIGHT ADJUSTMENT PEDAL (TRACK MODELS ONLY)	16
4. PRE-OPERATION CHECK	17
FUEL LEVEL	17
ENGINE OIL LEVEL	18
5. STARTING THE ENGINE	19
6. SNOWBLOWER OPERATION	22
7. STOPPING THE ENGINE	24
8. MAINTENANCE	25
MAINTENANCE SCHEDULE	26
TOOL KIT	27
ENGINE OIL CHANGE	28
SPARK PLUG SERVICE	29
TRACK-ADJUSTMENT (TRACK MODELS ONLY)	30
9. STORAGE	31
10. TROUBLESHOOTING	34
11. SPECIFICATIONS	35
12. WARRANTY SERVICE	37

1. SAFETY INSTRUCTIONS

WARNING

To ensure safe operation—

- Read this owner's manual thoroughly and understand the operating procedure before using the snowblower. Never permit anyone to operate the snowblower without proper instructions.
- Do not allow children to operate the snowblower. Keep children and pets away from the area of operation.
- Be properly dressed in winter clothing. Wear slip-proof winter boots.
- Before operating the snowblower, inspect the area you are going to clear of snow. Remove doormats, sleds, sticks, boards, wires and other obstacles before using the snowblower.
- Never use the snowblower to clear snow from a gravel road or drive, as rocks may be picked up and thrown.
- Don't use the snowblower where visibility is bad, or at nighttime under poor lighting conditions.
- Inspect the snowblower before operating it. If it is malfunctioning, repair it before operating it.
- Be careful in turning the direction of the snowblower, while operating it on a slope. Do not use the snowblower to remove snow from roofs and from steep slopes.
- The snowblower may not stand by itself on slopes; do not leave it unattended.

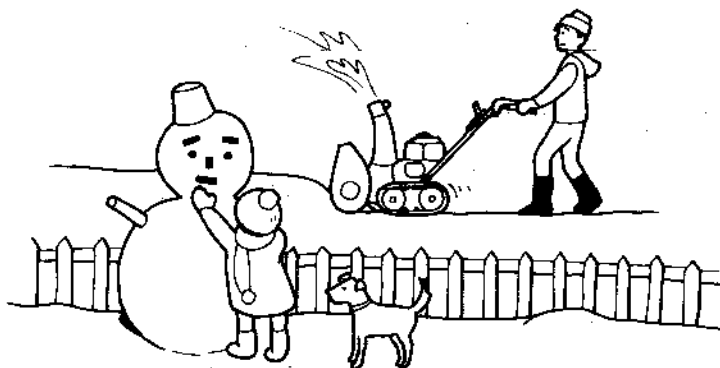

 **WARNING**

- **Adjust the snow chute to avoid hitting bystanders, windows, etc. with thrown snow. Stay clear of the discharge opening.**
- **While operating the snowblower, always hold the handle firmly and walk, don't run.**
- **If people or pets suddenly appear in front of the snowblower, while it is in operation, immediately release the auger and drive clutch levers.**
- **If you hit an obstacle while operating the snowblower, stop the engine immediately and check the machinery for damage. Don't operate a damaged machine because you may cause an accident.**
- **Before unclogging the discharge guide, turn the engine OFF.**
- **Exhaust gas contains poisonous carbon monoxide.
Never run the snowblower in an enclosed area.
Be sure to provide adequate ventilation.**
- **Gasoline is extremely flammable and explosive under certain conditions. Refuel in a well ventilated area with the engine stopped.**
- **When transporting the snowblower, turn the fuel valve OFF and keep the snowblower level to prevent fuel spillage.**

2. WARNING LABEL LOCATION

WARNING

DO NOT OVERFILL.



WARNING

- KEEP HANDS OUT OF DISCHARGE CHUTE.
- KEEP CLEAR OF THIS COLLECTOR AND DISCHARGE CHUTE WHILE ENGINE IS RUNNING.
- DO NOT DIRECT DISCHARGE AT BYSTANDERS OR WINDOW.
- BEFORE LEAVING OPERATOR'S POSITION
 1. DISENGAGE THROWER CLUTCH.
 2. STOP ENGINE.
- STOP ENGINE, WAIT FOR ALL MOVEMENT TO STOP AND REMOVE SPARK PLUG IGNITION WIRE BEFORE SERVICING MACHINE.

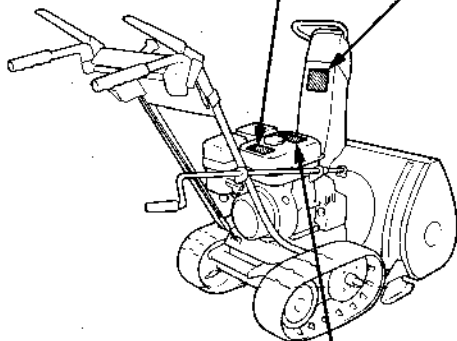

(HS55)

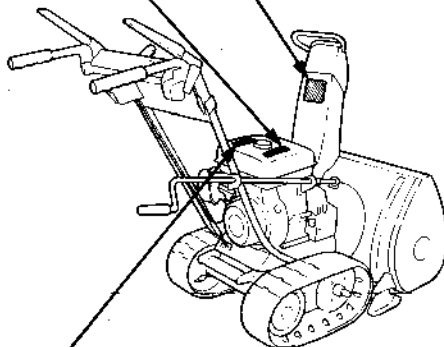

(HS70)



- CHECK FOR SPILLED FUEL OR FUEL LEAKS. STOP ENGINE BEFORE REFUELING.
- CONTRÔLER QU'IL N'Y A NI FUITE NI ESSENCE RÉPANDUE SUR L'APPAREIL. ARRÊTER LE MOTEUR AVANT DE REFAIRE LE PLEIN.
- INSPECCIONAR PARA COMBUSTIBLE DERRAMADO O ESCAPE. PARAR MOTOR ANTES DE ECHAR.

3. COMPONENT IDENTIFICATION AND FUNCTION

(HS55)

◀WHEEL TYPE▶

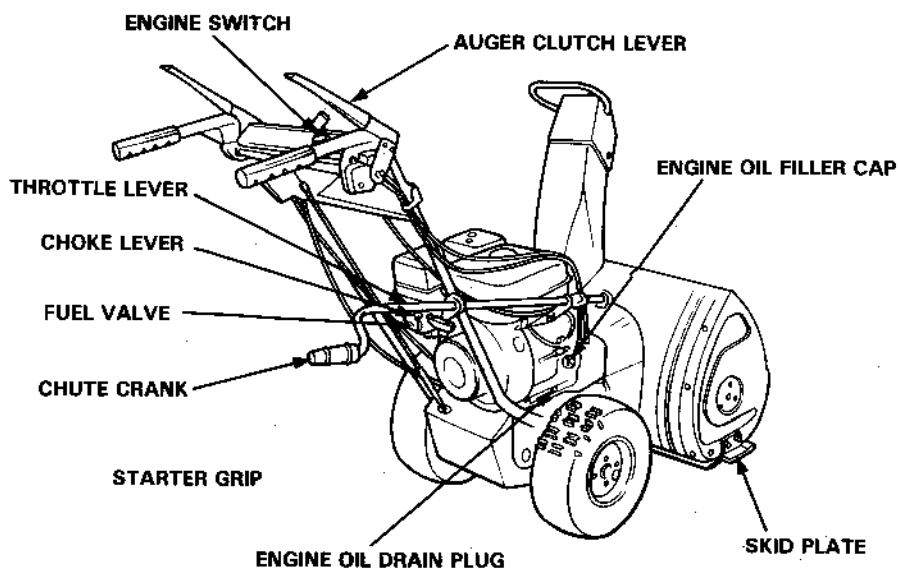
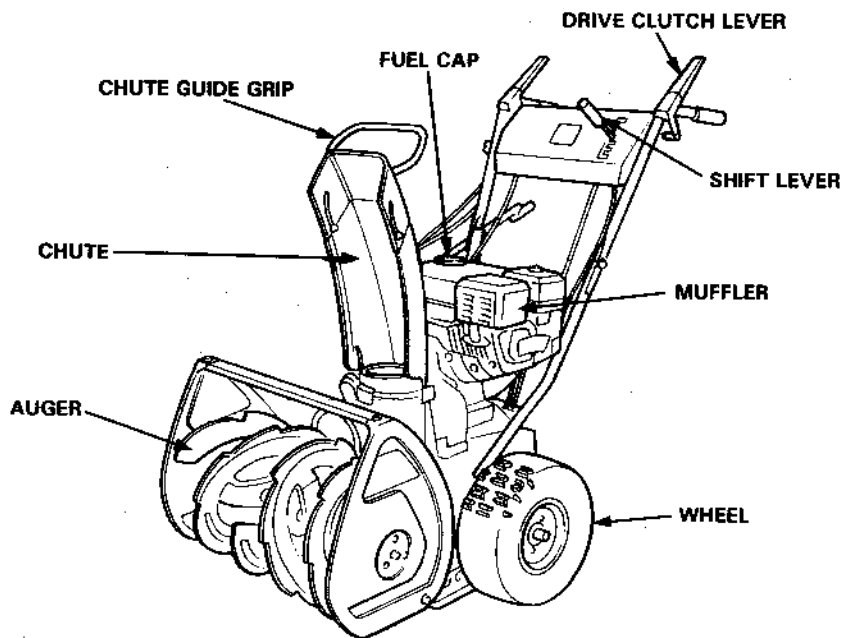

(HS55)
《TRACK TYPE》

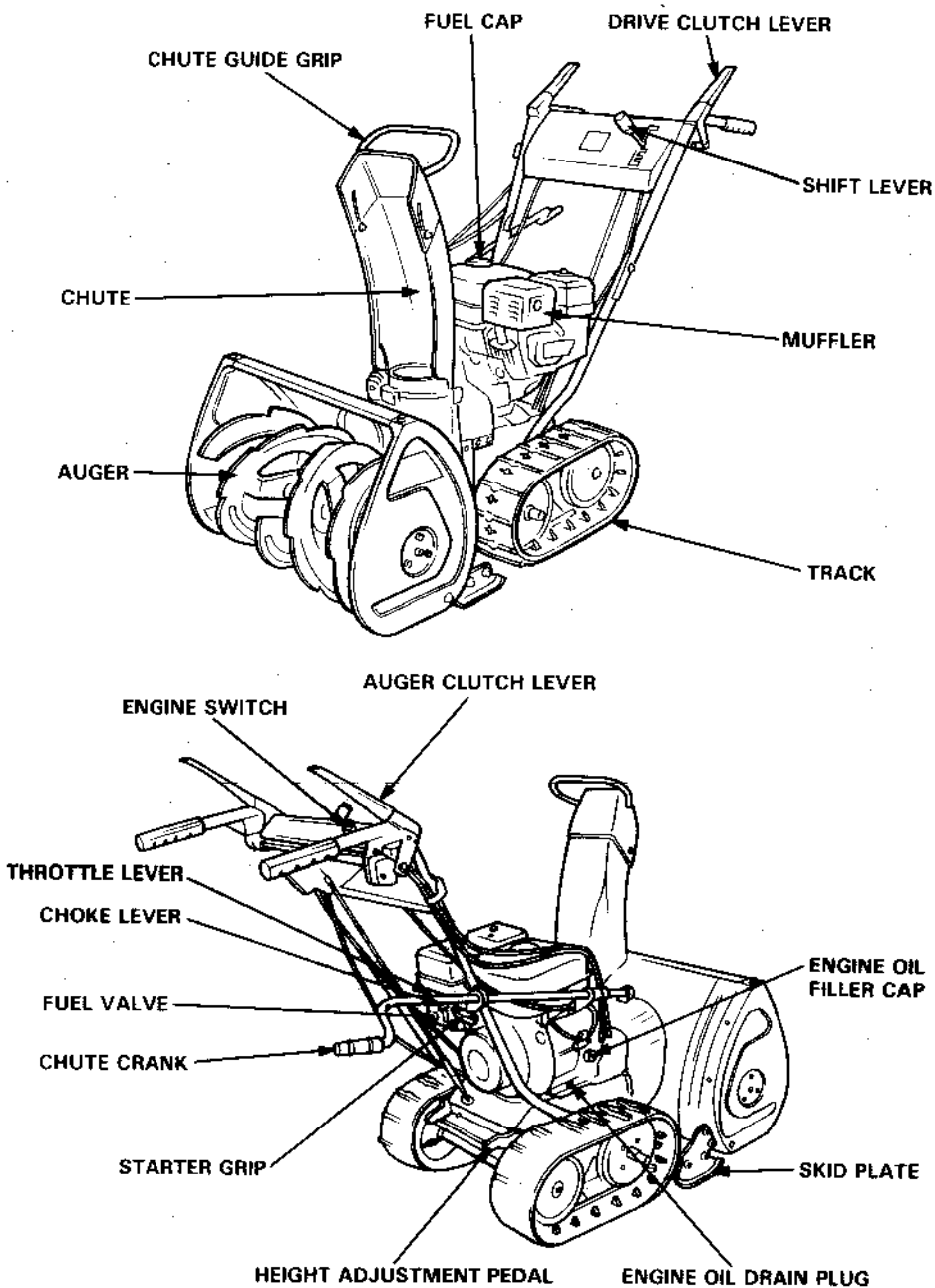

(HS70)
《WHEEL TYPE》

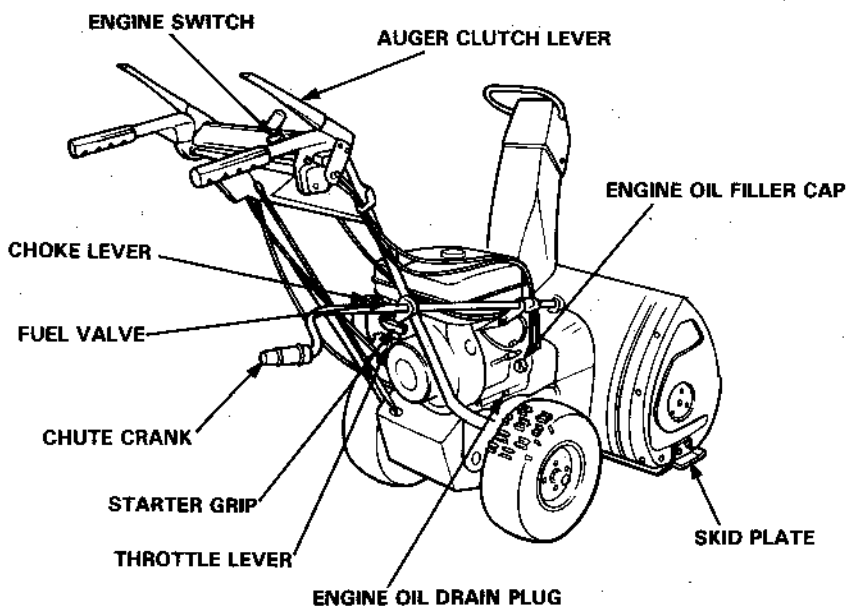
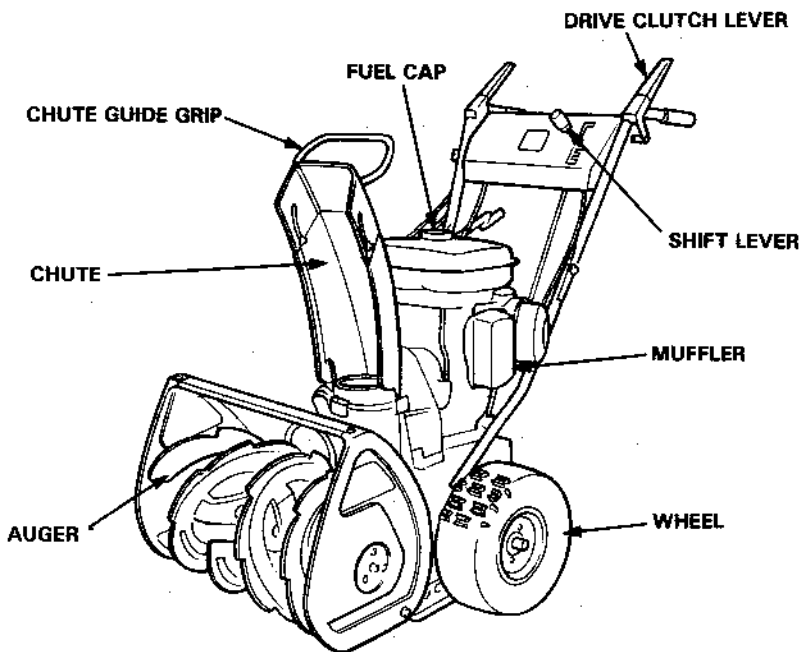

(HS70)
◀TRACK TYPE▶

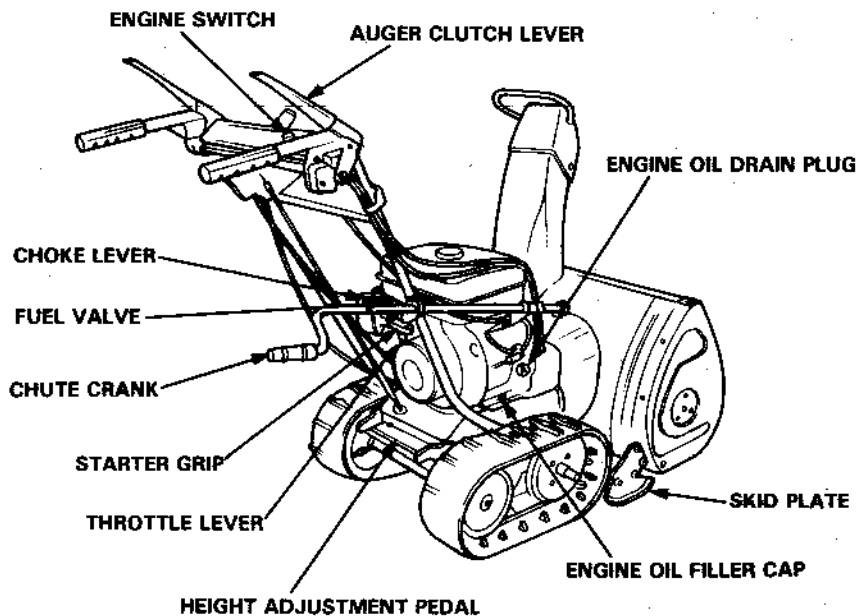
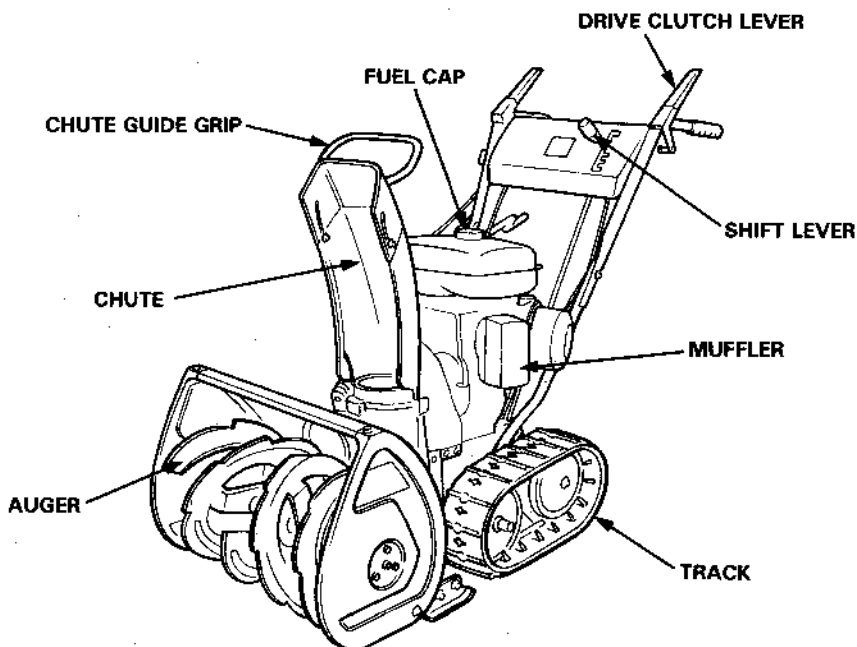

ENGINE SWITCH

Use the engine switch to **START** and **STOP** the engine.

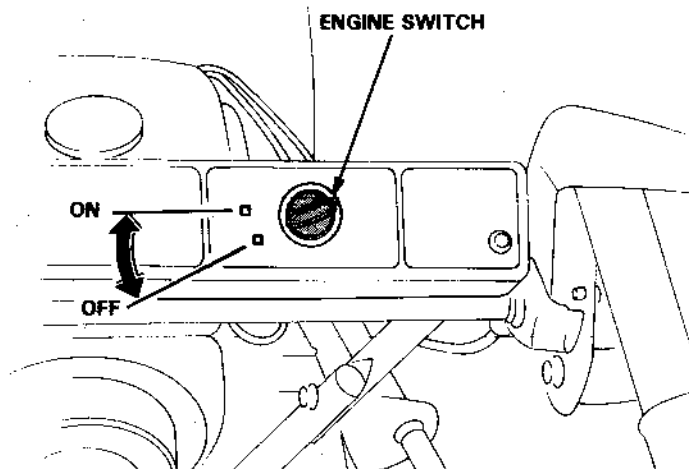

FUEL VALVE

The fuel valve opens and closes the fuel line leading from the fuel tank to the carburetor. Make sure that the valve is positioned exactly at either the **ON** or **OFF** position.

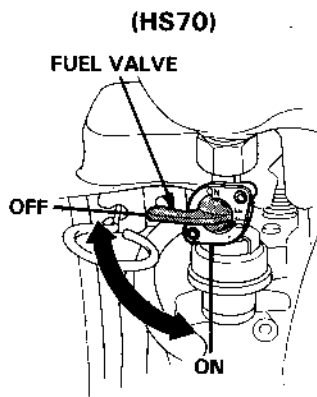
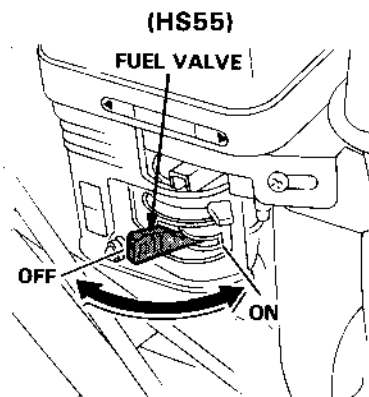

NOTE: Before transporting the snowblower, be sure to turn the fuel valve to **OFF** to prevent possible fuel leaks.

CHOKE LEVER/ROD

Close the choke when the engine is cold or difficult to start.

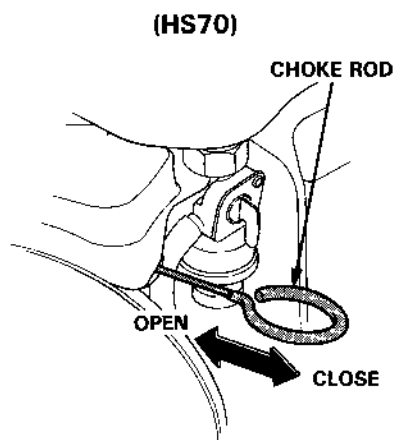
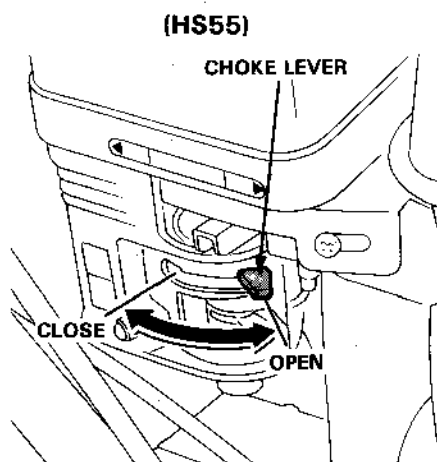

STARTER GRIP

Pull this grip to start the engine.

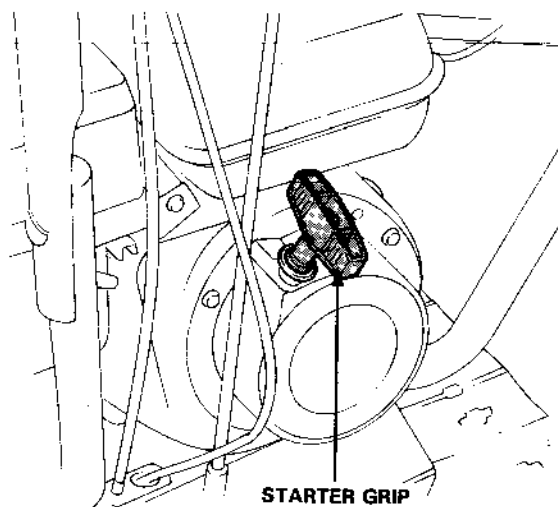

THROTTLE LEVER (ENGINE SPEED)

Use the throttle lever to select engine speed. In normal operation, use the FAST position.

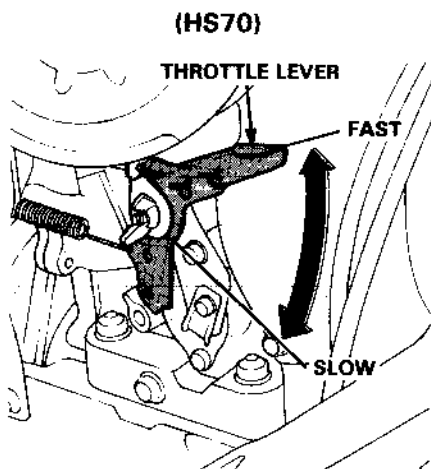
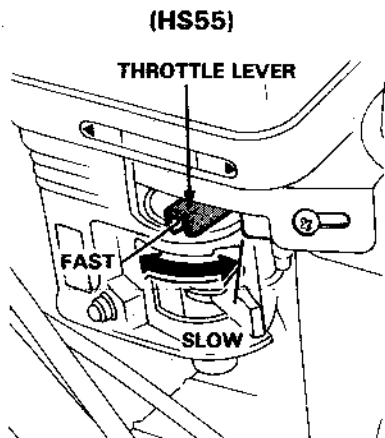

SHIFT LEVER

Use the shift lever to select drive speed or direction.

- 1: LOW SPEED
- 2: MEDIUM SPEED
- 3: HIGH SPEED
- N: NEUTRAL
- R: REVERSE

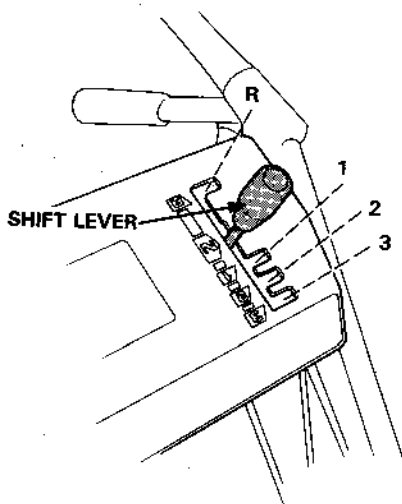

AUGER CLUTCH LEVER AND DRIVE CLUTCH LEVER

Use these controls to engage the snow blowing mechanism and/or the drive mechanism.

AUGER CLUTCH LEVER
Squeeze to engage the snow blowing mechanism.

DRIVE CLUTCH LEVER
Squeeze to engage the drive mechanism.

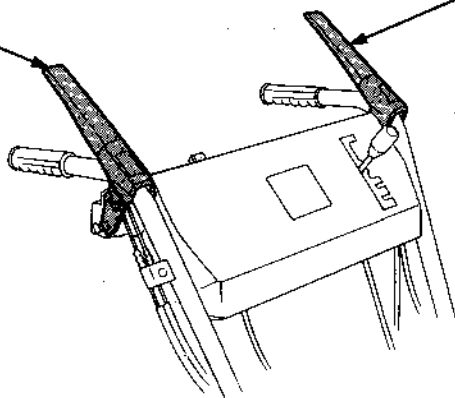

NOTE: When both levers are squeezed, the drive clutch lever locks the auger clutch lever down. Releasing the drive clutch lever then unlocks and releases the auger clutch lever.

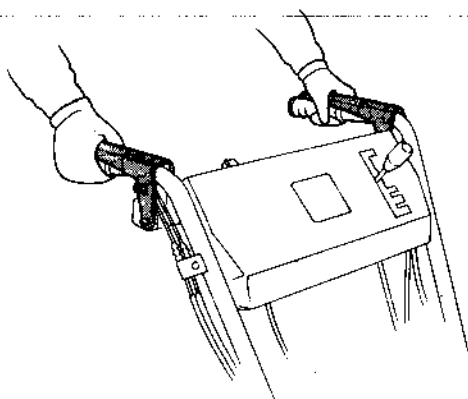

Both levers squeezed

LOCKED

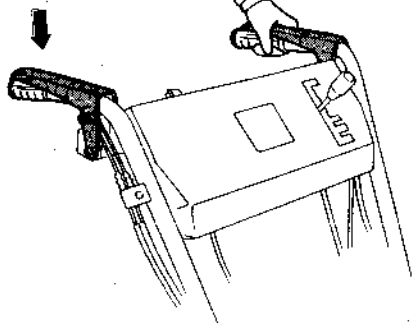

The auger clutch lever remains locked down so long as one hand continues to squeeze the drive clutch lever.

CHUTE CRANK

Use the chute crank to turn the snow discharge chute right or left.

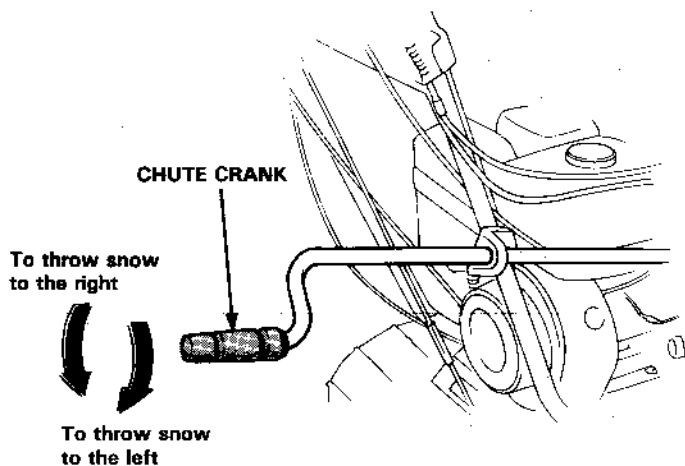

CHUTE GUIDE

The chute guide controls the snow discharge angle.

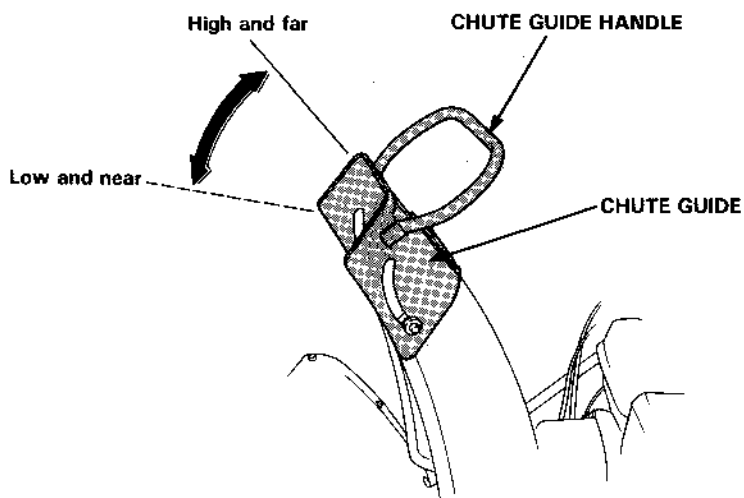

SKID PLATE

Adjust the skid plates for the auger housing ground clearance best suited to your snow removal conditions.

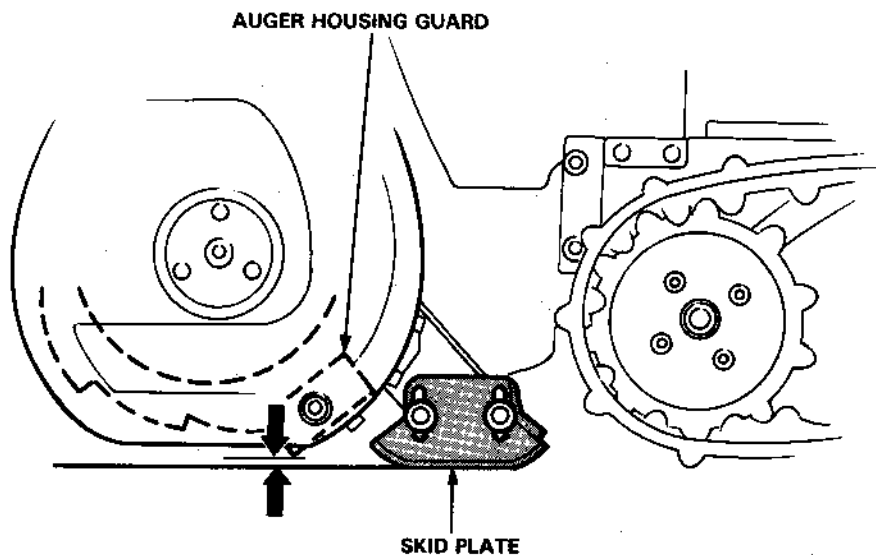

SNOW REMOVAL CONDITIONS	RECOMMENDED AUGER HOUSING GROUND CLEARANCE
For general use	6– 8 mm (0.24–0.31 in)
For use on uneven surfaces	10–30 mm (0.39–1.18 in)
For use on flat surfaces	0– 5 mm (0–0.20 in)

NOTE: Track models only — The position of the height adjustment pedal (p. 16) also affects auger housing ground clearance. Set the height adjustment pedal in the middle position before adjusting the skid plates.

HEIGHT ADJUSTMENT PEDAL (Track models only)

Use the pedal for adjusting the height and angle of the machine in relation to the tracks.

1. Hold the handles and step on the pedal.
2. Raise or lower the machine to the desired position and release the pedal.

LOW : Hard snow or fine finish

MIDDLE: Normal use

HIGH : Deep snow or for transporting the snowblower.

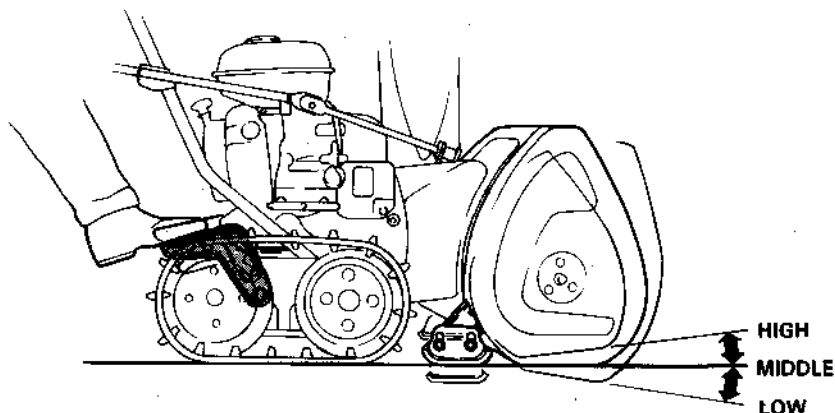

4. PRE-OPERATION CHECK

FUEL LEVEL

Inspection:

Unscrew the fuel cap. Check the fuel level.

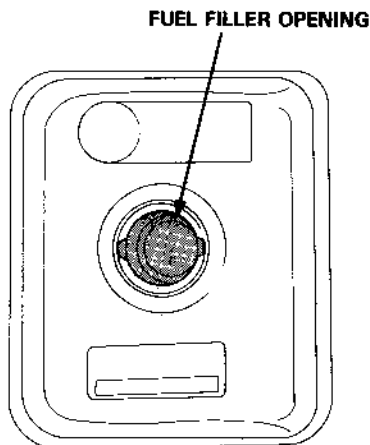

Refueling:

Use any regular grade automotive gasoline (unleaded gasoline is preferred) with a pump octane rating of 86 or higher. Never use an oil/gasoline mixture. Prevent dirt, dust or water from entering the fuel tank.

CAUTION: Gasoline substitutes are not recommended: they may be harmful to fuel system components.

FUEL TANK CAPACITY: HS55.....3.5ℓ (0.92 US gal, 0.77 Imp gal)
HS70.....6.0ℓ (1.58 US gal, 1.32 Imp gal)

WARNING

- Gasoline is extremely flammable and explosive under certain conditions. Refuel in a well ventilated area with the engine stopped.
- Do not smoke or allow flames or sparks in the area where the snowblower is being refueled or where gasoline is stored.
- Be careful not to spill fuel when refueling. Fuel vapor or spilled fuel may ignite. Make sure the area is dry of spilled fuel before starting the engine.
- Do not overfill the tank (there should be no fuel in the filler neck). After refueling, make sure the fuel cap is closed securely.
- Do not refuel in snow because snow will get into the fuel tank and cause an engine malfunction.

ENGINE OIL LEVEL

Inspection:

With the snowblower on a level surface, remove the oil filler cap and wipe the dipstick clean. Insert the dipstick into the filler neck, but do not screw it in. Remove the dipstick and check the oil level.

If the level is low, fill to the top of the oil filler neck with the recommended oil.

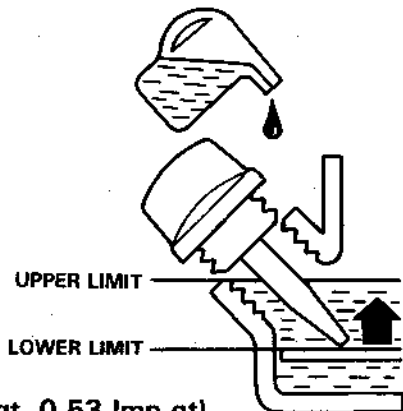
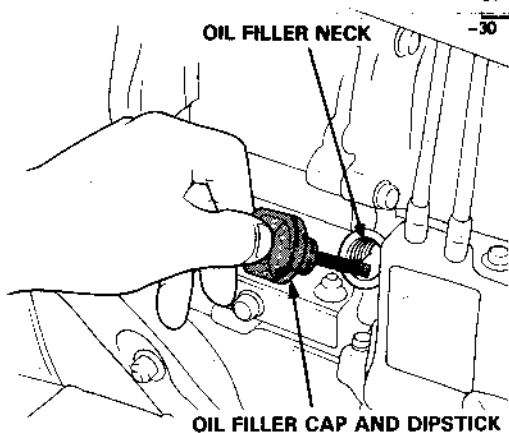
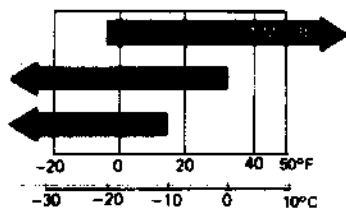

OIL CAPACITY: HS55.....0.6ℓ (0.63 US qt, 0.53 Imp qt)
HS70.....1.2ℓ (1.27 US qt, 1.06 Imp qt)

RECOMMENDED OIL:

Use high detergent, premium quality motor oil certified to meet or exceed U.S. automobile manufacturers' requirements for service classification SE or SF (Motor oils classified SE or SF will show this designation on the container.) Select the appropriate oil viscosity for the average temperature in your area, as shown in the chart above. SAE 5W-30 is recommended for general, all-temperature use.

CAUTION:

- Engine oil is a major factor affecting engine performance and service life. Non-detergent or vegetable oils are not recommended.
- Running the engine with insufficient oil can cause serious engine damage.

5. STARTING THE ENGINE

1. Turn the engine switch to the ON position.

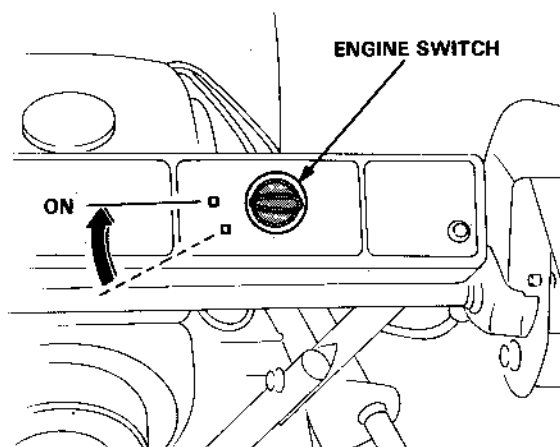

2. Turn the fuel valve to the ON position.

(HS55)

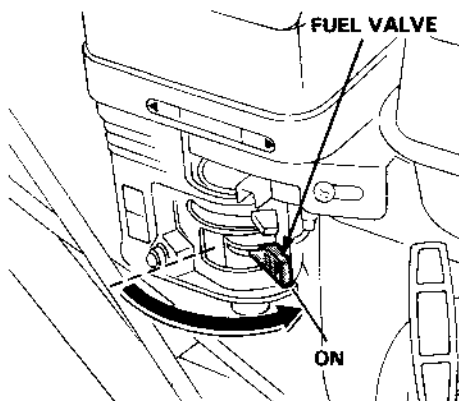

(HS70)

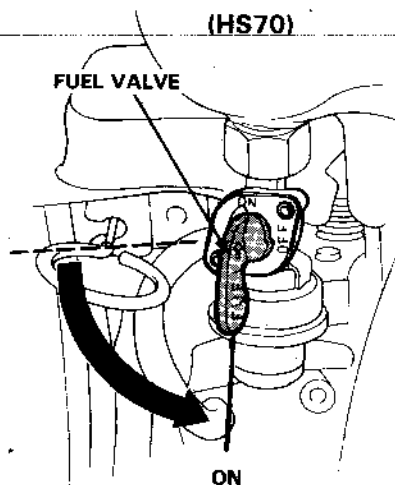

3. In cold weather and when the engine is cold, move the choke to the CLOSE position.

(HS55)

(HS70)

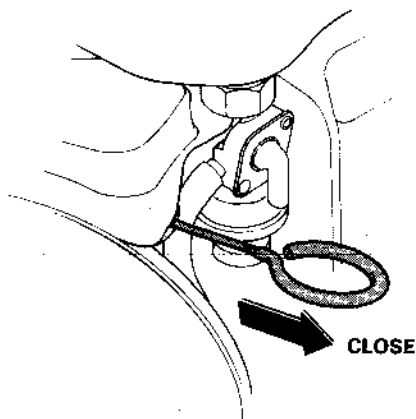
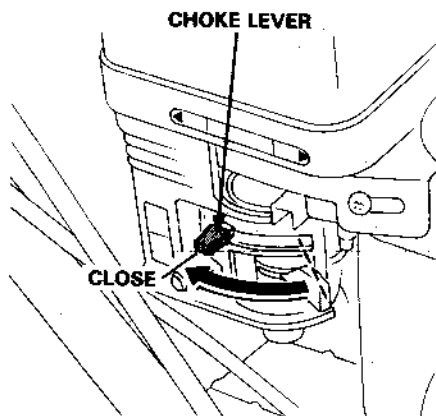

4. Pull the starter grip lightly until you feel resistance, then pull briskly.

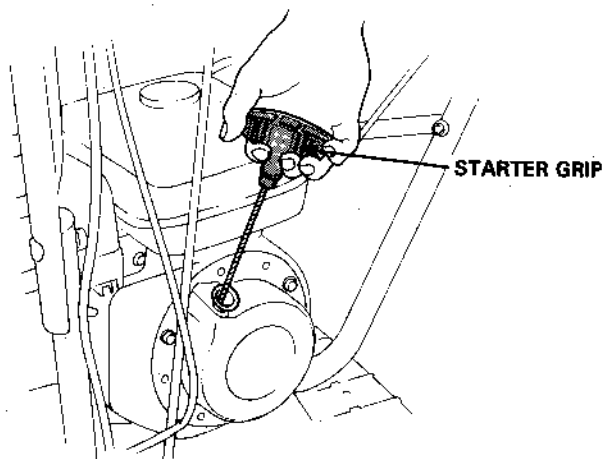

CAUTION: Don't allow the rope to snap back; return it gently by hand. Otherwise, the starting mechanism might be damaged. While the engine is in operation, don't pull the starter grip or damage may result.

5. Let the engine warm up for several minutes. If the choke has been turned to the CLOSE position, return it gradually to the OPEN position as the engine warms up.

(HS55)

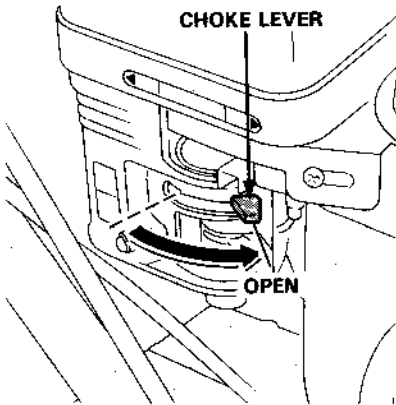

(HS70)

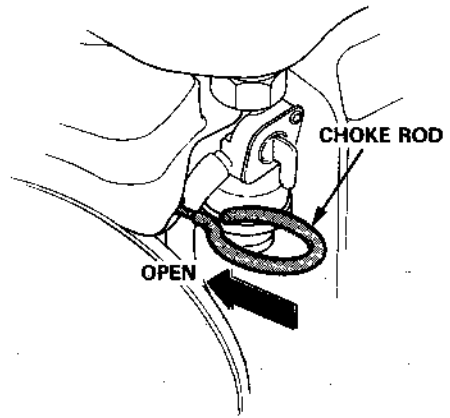

6. SNOWBLOWER OPERATION

1. Move the throttle lever (p. 12) to the FAST position for normal operation.
2. Move the shift lever (p. 12) to select the desired drive speed.

(DRIVE SPEED WITH THROTTLE LEVER IN THE FAST POSITION)

(HS55)

	Wheel type	Track type
1	0.43 m/s (1.41 ft/s)	0.28 m/s (0.92 ft/s)
2	0.74 m/s (2.43 ft/s)	0.48 m/s (1.57 ft/s)
3	1.01 m/s (3.31 ft/s)	1.10 m/s (3.61 ft/s)
R	0.68 m/s (2.23 ft/s)	0.74 m/s (2.43 ft/s)

(HS70)

	Wheel type	Track type
1	0.41 m/s (1.35 ft/s)	0.27 m/s (0.89 ft/s)
2	0.70 m/s (2.30 ft/s)	0.45 m/s (1.48 ft/s)
3	0.96 m/s (3.15 ft/s)	1.04 m/s (3.41 ft/s)
R	0.64 m/s (2.10 ft/s)	0.70 m/s (2.30 ft/s)

CAUTION: Be sure to set the shift lever into the groove. Do not shift between forward and reverse speeds while the machine is in motion.

NOTE: Low speed (1) is recommended for removing deep or hard-packed snow.

3. Track model only — Use the height adjustment pedal (p. 16) to adjust the height and angle of the machine.
4. Adjust the chute direction (p. 14) and chute guide angle (p. 14).
5. Squeeze the auger clutch lever and drive clutch lever (p. 13) to propel the machine and commence snow clearing.

High Altitude Operation

When operating this snowblower at high altitude, the air-fuel mixture becomes overly rich; engine performance may be reduced and fuel consumption increased.

See your authorized HONDA dealer for high altitude adjustment.

NOTE:

- To move the machine without engaging the snow-blowing mechanism, squeeze the drive clutch lever only. Do this when moving the machine to or from the area to be cleared.
- To engage the snow-blowing mechanism without using the drive mechanism, squeeze the auger clutch lever only. Do this if you wish to maneuver the machine manually while clearing snow.
- Squeeze both levers to propel the machine and clear snow simultaneously. When both levers are squeezed, the drive clutch lever locks the auger clutch lever down (p. 13). The auger clutch lever remains locked down so long as one hand continues to squeeze the drive clutch lever. Releasing the drive clutch lever then unlocks and releases the auger clutch lever.
- If the snow is deeper than the height of the auger, move the machine back and forth to remove snow gradually.
- For best efficiency, clear snow before it melts, refreezes and hardens.

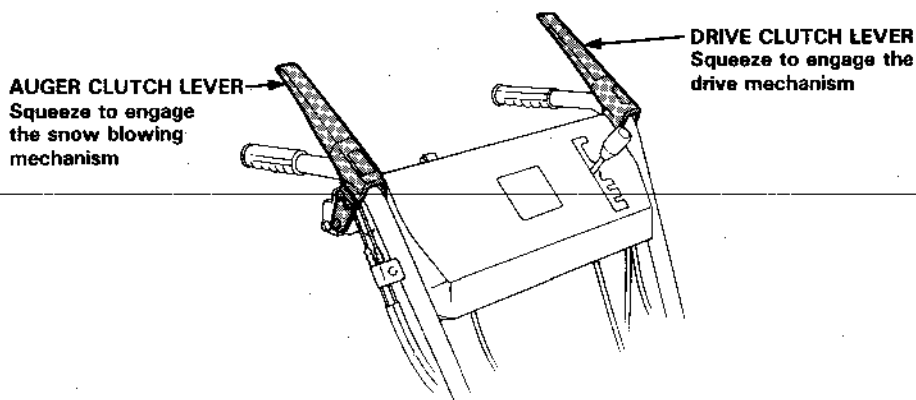

7. STOPPING THE ENGINE

To stop the engine in an emergency, turn the engine switch OFF immediately.

1. Turn the throttle lever to the SLOW position and turn the engine switch to the OFF position.

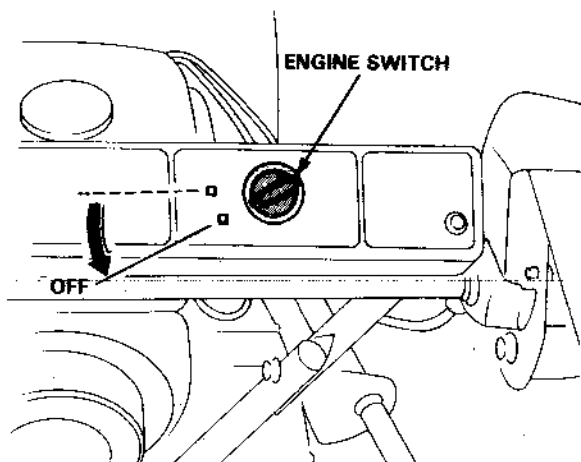

2. Turn the fuel valve to the OFF position.

(HS55)

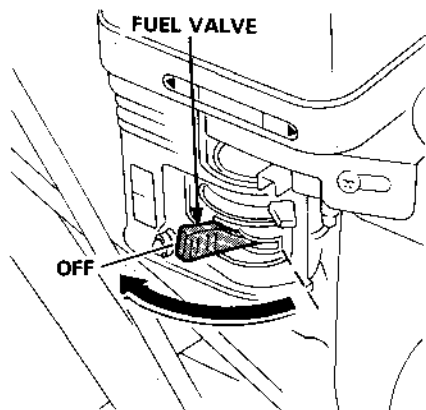

(HS70)

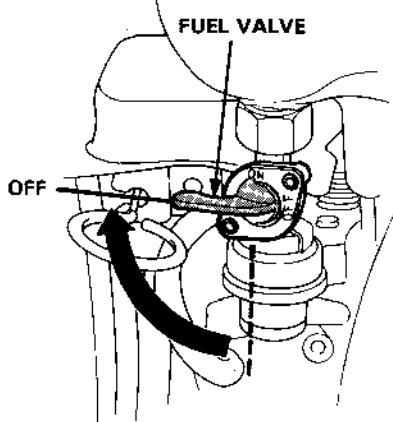

The purpose of inspection and maintenance is to keep the snowblower in the best operating condition.

Inspect or service as scheduled in the table on the next page.

 **WARNING** Shut off the engine before performing inspection and maintenance, and remove the spark plug wire from the plug so the engine cannot be started. If the engine must be run, make sure the area is well ventilated. The exhaust contains poisonous carbon monoxide gas.

CAUTION:

- Place the snowblower on a level surface before performing inspection and maintenance.
- Use only genuine HONDA parts or their equivalent. The use of replacement parts which are not of equivalent quality may damage the snowblower.

MAINTENANCE SCHEDULE

SERVICE PERIOD		EACH USE	EVERY YEAR		EVERY 5 YEARS
			BEFORE OPERATION	BEFORE STORAGE	
Engine oil	Check level	○			
	Change	First 20 hours operation			
Auger and blower	Check	○	○		
	Apply oil			○	
Spark plug	Clean-Readjust		○		
Auger clutch cable	Adjust		○		○ (1) (2)
Drive clutch cable	Adjust		○		○ (1) (2)
Track	Adjust		○		
Drive belt	Check		○		
	Change				○ (1) (2)
Nuts, bolts, fasteners	Check		○		
Fuel tank and carburetor	Drain			○	
Friction disc rubber	Check			○ (1) (2)	
Fuel line	Check (Replace if necessary)	Every 3 years			
Valve clearance	Check-Readjust				○ (2)
Fuel tank	Clean				○ (2)

- (1) These parts may require more frequent inspection and replacement under heavy use.
- (2) These items should be serviced by an authorized Honda dealer, unless the owner has the proper tools and is mechanically proficient. See the Honda Shop Manual for service information.

TOOL KIT

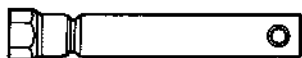

SPARK PLUG WRENCH

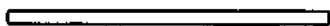

WRENCH HANDLE

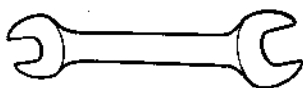

14 X 10 mm WRENCH

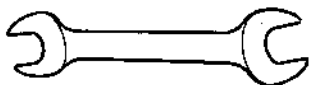

14 X 12 mm WRENCH

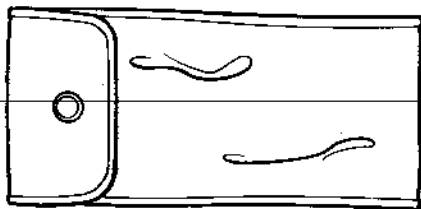

TOOL BAG

ENGINE OIL CHANGE

Drain the oil while the engine is still warm to assure rapid and complete draining.

1. Remove the drain plug and filler cap, and drain the oil. Retighten the plug securely.
2. Fill the crankcase with the recommended oil (see page 18) and check the level.

OIL CAPACITY: HS55.....0.6ℓ (0.63 US qt, 0.53 Imp qt)
HS70.....1.2ℓ (1.27 US qt, 1.06 Imp qt)

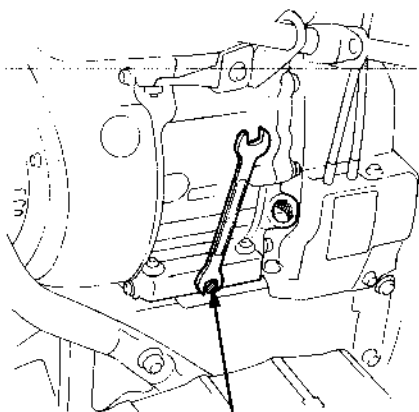

DRAIN BOLT

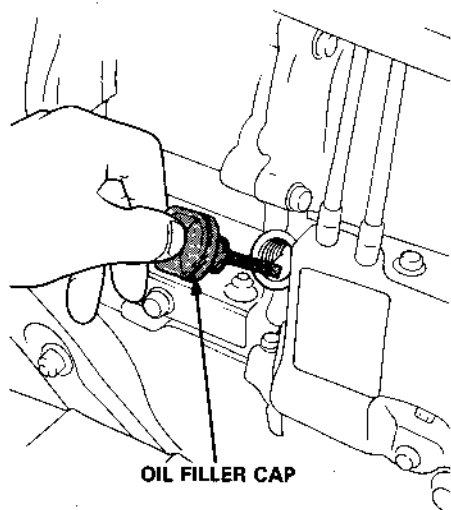
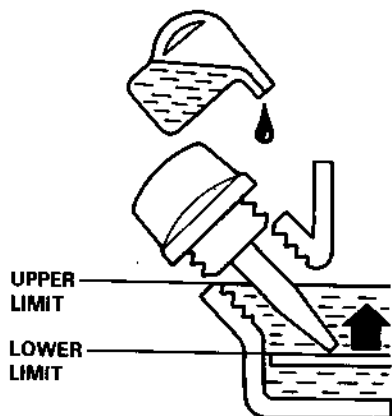

OIL FILLER CAP

SPARK PLUG SERVICE

**Recommended spark plug: HS55.....BPR5ES (NGK)
HS70.....BR-4HS (NGK)**

To ensure proper engine operation, the spark plug must be properly gapped and free of deposits.

1. Remove the spark plug cap.
2. Use the wrench supplied in the tool kit to remove the spark plug.
3. Visually inspect the spark plug. Discard it if the insulator is cracked or chipped.
4. Measure the plug gap with a feeler gauge.
HS55.....0.7–0.8 mm (0.027–0.031 in)
HS70.....0.6–0.7 mm (0.024–0.028 in)
Correct as necessary by bending the side electrode.
5. Thread the plug in by hand to prevent cross-threading.
6. Tighten a new spark plug 1/2 turn with the wrench to compress the washer.

If you are reusing a plug, it should only take 1/8–1/4 turn after the plug seats.

CAUTION:

- The spark plug must be securely tightened. An improperly tightened plug can become very hot and possibly damage the engine.
- Never use a spark plug with an improper heat range.

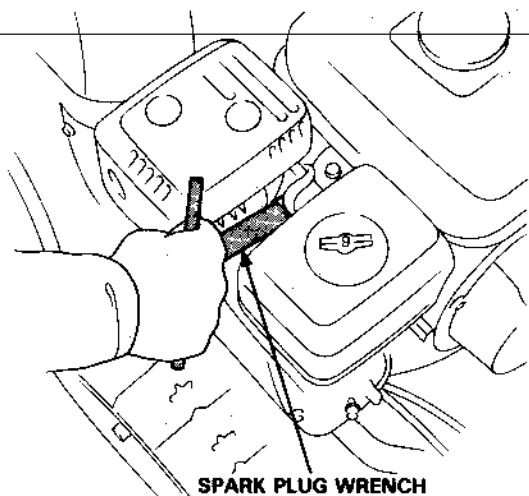

SPARK PLUG WRENCH

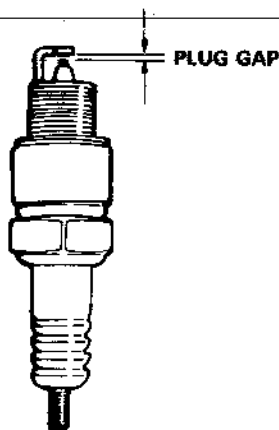

TRACK-ADJUSTMENT (Track models only)

Clean and thaw the tracks before adjustment. The tracks cannot be correctly adjusted if clogged with snow or debris, or coated with ice.

Check track deflection midway between the wheels. When correctly adjusted, the track will deflect 19–25 mm (3/4–1 in) when pressed with a force of 15 Kg (33 lb).

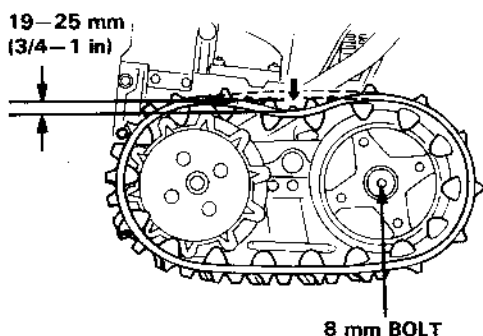

Adjustment:

1. Loosen the 8 mm bolt at the center of each rear wheel.
2. Loosen the left and right tension bolt lock nuts at the rear axle, and turn the adjusting nuts to correctly tension both tracks.
3. After adjustment, retighten the lock nuts and rear wheel bolts.

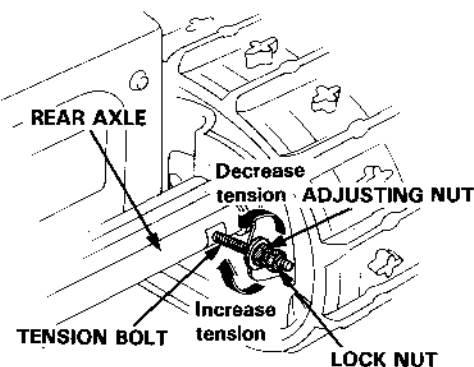

9. STORAGE

Before storing the snowblower for an extended period:

1. Be sure the storage area is free of excessive humidity and dust.
2. Drain the fuel—

WARNING Gasoline is extremely flammable and explosive under certain conditions. Do not smoke or allow flames or sparks in the area.

- a. Turn the fuel valve ON.

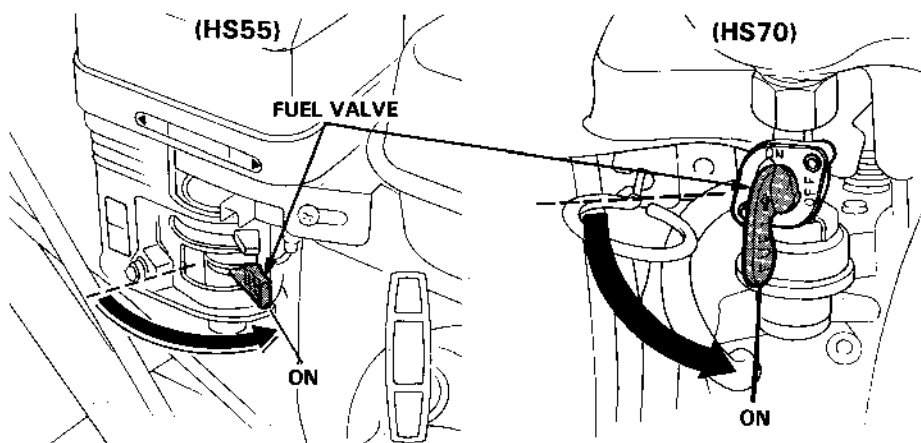

- b. Loosen the carburetor drain screw, and drain the gasoline into a suitable container. After draining, retighten the drain screw and turn the fuel valve OFF.

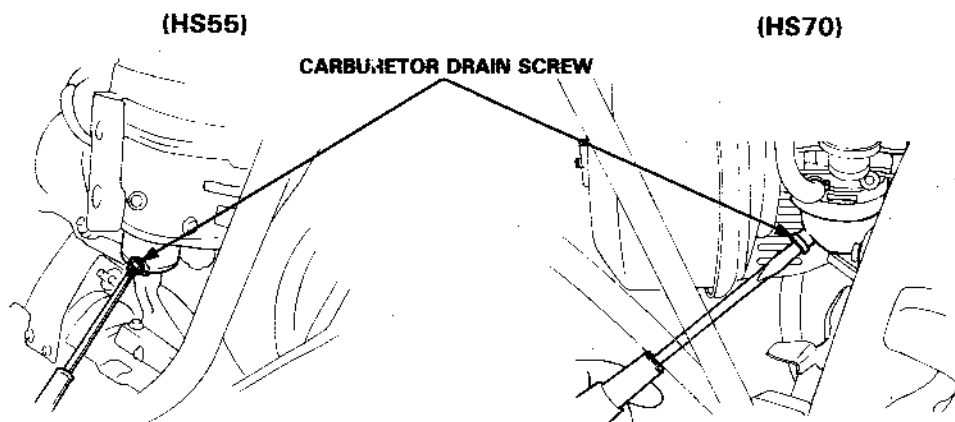

Remove the spark plug and pour three tablespoonsful of clean motor oil into the cylinder. Pull the starter rope slowly two or three times to distribute the oil. Reinstall the spark plug.

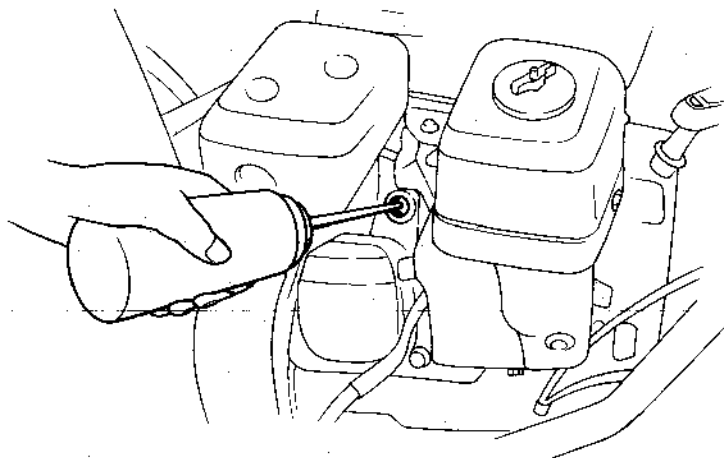

Pull the starter grip until resistance is felt. This closes the valves and protects the engine from internal corrosion.

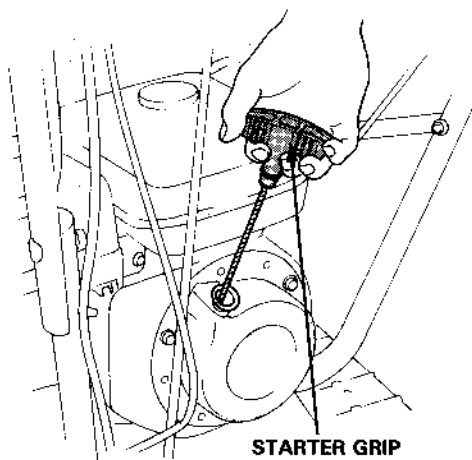

Apply oil to the following parts for lubrication and rust prevention.

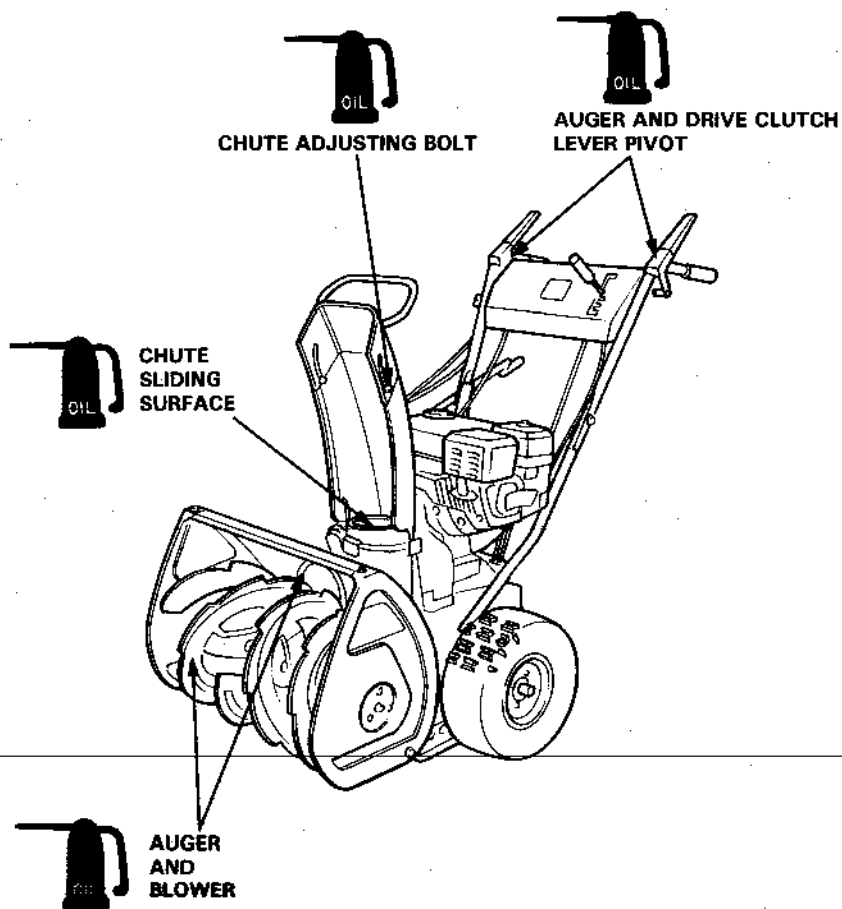

10. TROUBLESHOOTING

When the engine will not start:

1. Is there enough fuel?
2. Is the fuel valve on?
3. Is gasoline reaching the carburetor?

To check, loosen the drain screw with the fuel valve on. Fuel should flow freely.

WARNING If any fuel is spilled, make sure the area is dry before testing the spark plug or starting the engine. Fuel vapor or spilled fuel may ignite.

4. Is the engine switch on?
5. Is there a spark at the spark plug?
 - a. Remove the spark plug cap. Clean any dirt from around the spark plug base, then remove the spark plug.
 - b. Install the spark plug in the plug cap.
 - c. Turn the engine switch on.
 - d. Grounding the side electrode to any engine ground, crank the engine to see if sparks jump across the gap.
 - e. If there are no sparks, replace the plug.If OK, try to start the engine according to the instructions.
6. If the engine still does not start, take the snowblower to an authorized Honda snowblower dealer.

When the auger or blower will not operate:

Check the shear bolts and replace if broken off.

Secure the shear bolts with 6 mm nuts.

Three spare shear bolts are supplied with the snowblower.

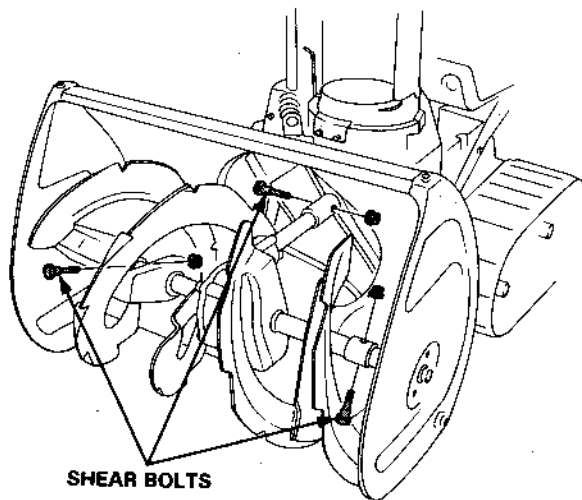

11. SPECIFICATIONS

(HS55)

Engine

Model:	HONDA GX140
Maximum output:	5.5 HP/4200 r.p.m
Displacement:	144 cm ³ (8.8 cu. in)
Bore x stroke:	64 X 45 mm (2.5 X 1.8 in)
Starting method:	Recoil starter
Ignition system:	Transistorized magneto
Oil capacity:	0.6ℓ (0.63 US qt, 0.53 Imp qt)
Fuel tank capacity:	3.5ℓ (0.92 US gal, 0.77 Imp gal)
Spark plug:	BPR5ES (NGK)

Frame

Items \ Type	Wheel type	Track type
Overall length	1310 mm (51.6 in)	1235 mm (48.6 in)
Overall width	663 mm (26.1 in)	550 mm (21.7 in)
Overall height	1029 mm (40.5 in)	975 mm (38.4 in)
Dry weight	80 kg (173 lb)	76 kg (168 lb)
Width of snow clearance	605 mm (23.8 in)	550 mm (21.7 in)
Height of snow clearance	470 mm (18.5 in)	415 mm (16.3 in)
Snow throwing distance (differs according to the kind of snow)	Max. 12 m (39.4 ft)	Max. 12 m (39.4 ft)
Clearing capacity	37 Ton/hour	35 Ton/hour
Continuous operating time	3 hours	3 hours

(HS70)

Engine

Model:	HONDA G300
Maximum output:	7.0 HP/4000 r.p.m
Displacement:	272 cm ³ (16.6 cu. in)
Bore x stroke:	76 X 60 mm (3.0 X 2.4 in)
Starting method:	Recoil starter
Ignition system:	Flywheel magneto type
Oil capacity:	1.2ℓ (1.27 US qt, 1.06 Imp qt)
Fuel tank capacity:	6.0ℓ (1.58 US gal, 1.32 Imp gal)
Spark plug:	BR-4HS (NGK)

Frame

Items	Type	Wheel type	Track type
	Overall length		1380 mm (54.3 in)
Overall width		663 mm (26.1 in)	663 mm (26.1 in)
Overall height		1029 mm (40.5 in)	1029 mm (40.5 in)
Dry weight		90 kg (198 lb)	91 kg (201 lb)
Width of snow clearance		605 mm (23.8 in)	605 mm (23.8 in)
Height of snow clearance		470 mm (18.5 in)	470 mm (18.5 in)
Snow throwing distance (differs according to the kind of snow)		Max. 12 m (39.4 ft)	Max. 12 m (39.4 ft)
Clearing capacity		38 Ton/hour	38 Ton/hour
Continuous operating time		2.5 hours	2.5 hours

Owner Satisfaction

Your satisfaction and goodwill are important to your dealer and to us. Normally, any problems with the product will be handled by your dealer's service department. Sometimes, however, despite the best intentions of all concerned, misunderstandings can occur. If your problem has not been handled to your satisfaction, we suggest you take the following action:

- Discuss your problem with a member of dealership management. Often complaints can be quickly resolved at that level. If the problem has already been reviewed with the Service Manager, contact the owner of the dealership or the General Manager.

- If your problem still has not been resolved to your satisfaction, contact the Customer Relations Department at the regional office of American Honda Motor Co., Inc. in your area. Regional office locations are shown on the following page. We will need the following information in order to assist you:
 - Your name, address, and telephone number
 - Product model and serial number
 - Date of purchase
 - Dealer name and address
 - Nature of the problem

After reviewing all the facts involved, you will be advised of what action can be taken. Please bear in mind that your problem will likely be resolved at the dealership, using the dealer's facilities, equipment, and personnel, so it is very important that your initial contact be with the dealer.

Your purchase of a Honda product is greatly appreciated by both the dealer and American Honda Motor Co., Inc. We want to assist you in every way possible to assure your complete satisfaction with your purchase.

Regional Office Locations

NORTHWEST REGIONAL OFFICE
(includes Alaska)
American Honda Motor Co., Inc.
Customer Relations Department
P.O. Box 30285
Portland, Oregon 97220
Telephone: (503) 255-1186

MIDWEST REGIONAL OFFICE
American Honda Motor Co., Inc.
Customer Relations Department
P.O. Box 22
Greendale, Wisconsin 53129
Telephone: (414) 421-9300

NORTHEAST REGIONAL OFFICE
American Honda Motor Co., Inc.
Customer Relations Department
P.O. Box 749
Moorestown, New Jersey 08057
Telephone: (609) 778-1100

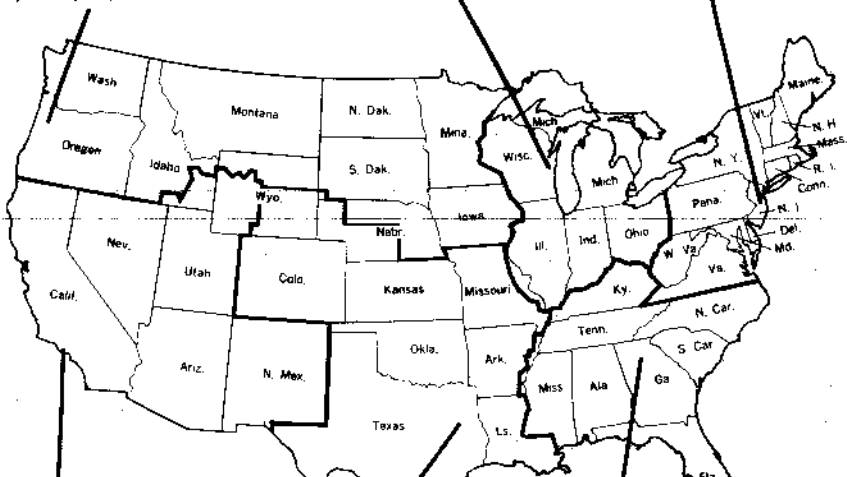

WESTERN REGIONAL OFFICE
(includes Hawaii)
American Honda Motor Co., Inc.
Customer Relations Department
P.O. Box 420
Gardens, California 90247
Telephone: (213) 604-2524

SOUTHWEST REGIONAL OFFICE
American Honda Motor Co., Inc.
Customer Relations Department
P.O. Box 5405
Irving, Texas 75062
Telephone: (214) 258-6883

SOUTHEAST REGIONAL OFFICE
(includes Puerto Rico)
American Honda Motor Co., Inc.
Customer Relations Department
6684 Jimmy Carter Boulevard
Norcross, Georgia 30071
Telephone: (404) 448-1992



HONDA
HONDA MOTOR CO., LTD. TOKYO, JAPAN

31736010
00X31-736-0100

Ⓢ Ⓜ 10008407
PRINTED IN JAPAN