

HONDA

Power

Equipment

Owner's Manual

Trimmer/Brush Cutter

HHT25S • HHT31S

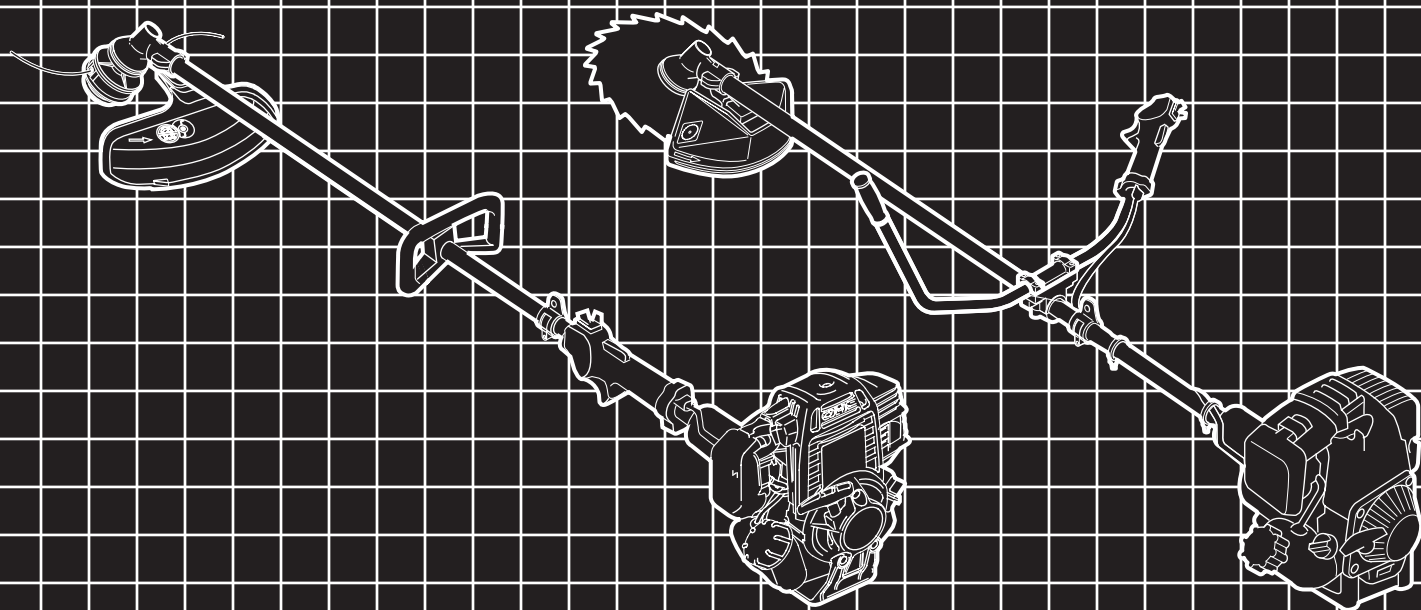

*See page 42 for instructions on
assembling your Trimmer.*



WARNING:



The engine exhaust from this product contains chemicals known to the State of California to cause cancer, birth defects or other reproductive harm.

Keep this owner's manual handy, so you can refer to it at any time. This owner's manual is considered a permanent part of the trimmer/brush cutter and should remain with the trimmer/brush cutter if resold.

The information and specifications included in this publication were in effect at the time of approval for printing. American Honda Motor Co., Inc. reserves the right, however, to discontinue or change specifications or design at any time without notice and without incurring any obligation whatever. No part of this publication may be reproduced without written permission.

INTRODUCTION

Congratulations on your selection of a Honda trimmer/brush cutter. We are certain you will be pleased with your purchase of one of the finest trimmer/brush cutters on the market.

We want to help you get the best results from your new trimmer/brush cutter and to operate it safely. This manual contains the information on how to do that; please read it carefully.

As you read this manual, you will find information preceded by a **NOTICE** symbol. That information is intended to help you avoid damage to your trimmer/brush cutter, other property, or the environment.

We suggest you read the warranty policy to fully understand its coverage and your responsibilities of ownership. The warranty policy is a separate document that should have been given to you by your dealer.

When your trimmer/brush cutter needs scheduled maintenance, keep in mind that your Honda servicing dealer is specially trained in servicing Honda trimmers/brush cutters. Your Honda servicing dealer is dedicated to your satisfaction, and will be pleased to answer your questions and concerns.

Best Wishes,

Power Equipment Division
American Honda Motor Co., Inc.

INTRODUCTION

A FEW WORDS ABOUT SAFETY

Your safety, and the safety of others, are very important. And using this trimmer/brush cutter safely is an important responsibility.

To help you make informed decisions about safety, we have provided operating procedures and other information on labels and in this manual. This information alerts you to potential hazards that could hurt you or others.

Of course, it is not practical or possible to warn you about all the hazards associated with operating or maintaining a trimmer/brush cutter. You must use your own good judgment.

You will find important safety information in a variety of forms, including:

- **Safety Labels**—on the trimmer/brush cutter.
- **Safety Messages**—preceded by a safety alert symbol  and one of three signal words, DANGER, WARNING, or CAUTION.

These signal words mean:

 **DANGER**

You WILL be KILLED or SERIOUSLY HURT if you don't follow instructions.

 **WARNING**

You CAN be KILLED or SERIOUSLY HURT if you don't follow instructions.

 **CAUTION**

You CAN be HURT if you don't follow instructions.

- **Safety Headings**—such as *IMPORTANT SAFETY INFORMATION*.
- **Safety Section**—such as *TRIMMER SAFETY*.
- **Instructions**—how to use this trimmer/brush cutter correctly and safely.

This entire book is filled with important safety information—please read it carefully.

CONTENTS

TRIMMER SAFETY	4
IMPORTANT SAFETY INFORMATION	4
ATTACHMENTS & MODIFICATIONS	5
IMPORTANT MESSAGE TO EMPLOYERS	5
SAFETY LABEL LOCATIONS	6
RECOMMENDED CUTTING ATTACHMENTS	7
CUTTING-LINE HEADS AND SHIELDS	7
BLADES AND SHIELDS	8
CUTTING ATTACHMENT APPLICATIONS	9
CONTROLS & EQUIPMENT	10
CONTROLS	11
EQUIPMENT	13
BEFORE OPERATION	14
IS YOUR WORKING AREA READY?	14
OPERATION	17
SAFE OPERATING PRECAUTIONS	17
STARTING THE ENGINE	17
STOPPING THE ENGINE	19
TRIMMER/HARNESS QUICK DISCONNECTION	19
TRIMMER OPERATION	19
SAFE OPERATING PRACTICES	21
OPERATING TIPS	22
SERVICING YOUR HONDA TRIMMER	24
THE IMPORTANCE OF MAINTENANCE	24
MAINTENANCE SAFETY	24
MAINTENANCE SCHEDULE	25
ENGINE	26
CUTTING ATTACHMENTS	29
FUEL SYSTEM	40
ASSEMBLY	42
IMPORTANCE OF PROPER ASSEMBLY	42
IMPORTANT SAFETY PRECAUTIONS	42
UNPACKING	43
LOOSE PARTS	43
TRIMMER ASSEMBLY (UNBA types only)	44
BLADE COVER REMOVAL	47
BLADE COVER INSTALLATION	47
ENGINE OIL	48
BEFORE OPERATION	48
STORAGE	49
STORAGE PREPARATION	49
STORAGE PRECAUTIONS	50
REMOVAL FROM STORAGE	50
TRANSPORTING	51
TAKING CARE OF UNEXPECTED PROBLEMS	52
STARTING PROBLEMS	52
ENGINE OPERATING PROBLEMS	52
CUTTING HEAD PROBLEMS	53
TECHNICAL & CONSUMER INFORMATION	54
TECHNICAL INFORMATION	54
CONSUMER INFORMATION	60
INDEX	61
QUICK REFERENCE INFORMATION	Inside Back Cover

TRIMMER SAFETY

IMPORTANT SAFETY INFORMATION

The Honda HHT25S and HHT31S trimmer/brush cutters are designed to cut grass, weeds, brush, and/or wood if equipped with an appropriate cutting attachment. Other uses can result in injury to the operator or damage to the trimmer and other property.

These Honda trimmers are intended for use by gardening professionals. Never allow children to operate the trimmer.

Most accidents can be prevented if you follow all instructions in this manual and on the trimmer. The most common hazards are discussed below, along with the best way to protect yourself and others.

Always Wear Eye Protection and Protective Clothing

- The most frequent injuries associated with string trimmers are eye injuries caused by thrown debris. Always wear safety glasses or goggles that meet the ANSI Z87.1 rating whenever you use the trimmer.
- The operator must wear hearing protectors when using this trimmer. Hearing protectors will protect the operator's ears from noise damage.
- Wearing protective clothing also reduces the risk and severity of injury from thrown debris or contact with the cutting attachment. Wear the trimmer harness, gloves, a long-sleeved shirt, long pants, and sturdy boots with nonslip soles.
See page 14 for more information.

Keep Away From Cutting Lines and Blades

- A spinning cutting blade can cut through your clothes and skin just as easily as it cuts through grass and dirt. Keep all parts of your body away from a spinning cutting attachment.
- Even after the engine has stopped, the cutting attachment will spin for several seconds. Do not touch it until it has stopped spinning, or you may get cut.

Turn the Engine Off When Not Trimming

If you stop trimming or cutting for any reason, even to clean off the cutting attachment, always shut off the engine.

Keep People Away From Your Working Area

To prevent injury to others, keep people at least 50 feet (15 meters) away from the working area during operation.

Always Wear the Harness When Trimming

The harness keeps the trimmer away from your body, lowering your chances of being cut by the trimmer's blade or cutting line.

Read This Manual Before Using the Trimmer

Read the manual before operating the trimmer. Understand how to use all the controls and obey all warnings.

Clear the Working Area First

Objects thrown by the trimmer can cause serious injury. Before operating the trimmer, carefully inspect the area and remove any broken glass, pieces of wire, and other loose objects.

Keep the Trimmer Properly Maintained

- The cutting attachment should be examined for looseness, cracks, broken parts, or excessive wear. Tighten or replace as needed before operating the trimmer.
- Do not operate the trimmer without a debris shield properly installed. Make sure you have the right shield installed for your cutting attachment.
For more information, see pages 7 and 8.

ATTACHMENTS & MODIFICATIONS

Modifying your trimmer/brush cutter, or installing non-Honda attachments, can make your trimmer unsafe. Before you make any modifications or install any attachments, be sure to read the following information.

Attachments

Your Honda trimmer servicing dealer has cutting attachments, debris shields, barrier kits, and shoulder harnesses that have been designed and approved for your trimmer and are covered by warranty.

Non-Honda attachments are usually designed for universal applications. Although aftermarket attachments may fit on your trimmer, they may not meet factory specifications and could make your trimmer unsafe.

Modifications

Do not remove the debris shield or modify your trimmer in any way that would alter its design or operation. This could make your trimmer unsafe.

IMPORTANT MESSAGE TO EMPLOYERS

As an employer, you have special responsibilities to the people who work for you.

Before you ask anyone to operate this trimmer/brush cutter, you need to determine whether the operator is old enough, large enough, and strong enough to safely handle and control the trimmer/brush cutter.

If you decide he/she is, make sure the employee(s) read and understand all instructions and warnings in this manual and on the labels before operating the trimmer/brush cutter.

Allow adequate time for hands-on training by a qualified instructor, and personally supervise practice sessions, until you feel sure the employee is ready to operate the trimmer/brush cutter.

Also be sure employees wear proper clothing, eye and hearing protection, and any other gear that may be required by local ordinances or your insurance company.



Remember, too, that you are responsible for keeping the trimmer/brush cutter properly maintained and in safe operating condition.

Your commitment to safety on the job can help prevent accidents and result in longer and more productive years of service.

TRIMMER SAFETY

SAFETY LABEL LOCATIONS

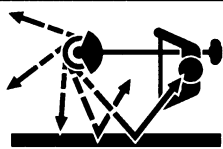
The labels shown here contain important safety information. Please read them carefully. These labels are considered permanent parts of your trimmer/brush cutter. If a label comes off or becomes hard to read, contact an authorized Honda servicing dealer for a replacement.

⚠ WARNING	
	READ AND FOLLOW OWNER'S MANUAL. Failure to do so can result in serious injury to the operator and bystanders.
⚠ WARNING	
	OBJECTS THROWN BY CUTTING ATTACHMENTS CAN CAUSE SERIOUS INJURY. <ul style="list-style-type: none">■ Always wear eye protection that meets ANSI Z87.1.■ Always wear hearing protection and protective clothing.■ Keep bystanders at least 50 feet (15m) away.■ Do not operate without shield.
⚠ WARNING	
	CONTACT WITH ROTATING CUTTING ATTACHMENT CAN CAUSE SERIOUS INJURY. <ul style="list-style-type: none">■ Keep away from rotating cutting attachment.■ Be aware of possible kickback when using blades. (See Owner's Manual for special operating precautions)■ Install proper shield, handle, and harness for cutting attachment.■ Use only Honda recommended cutting attachments.

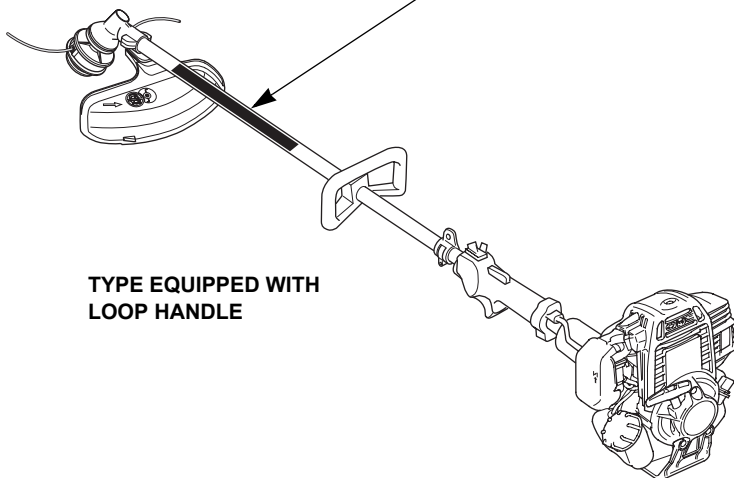

TYPE EQUIPPED WITH LOOP HANDLE

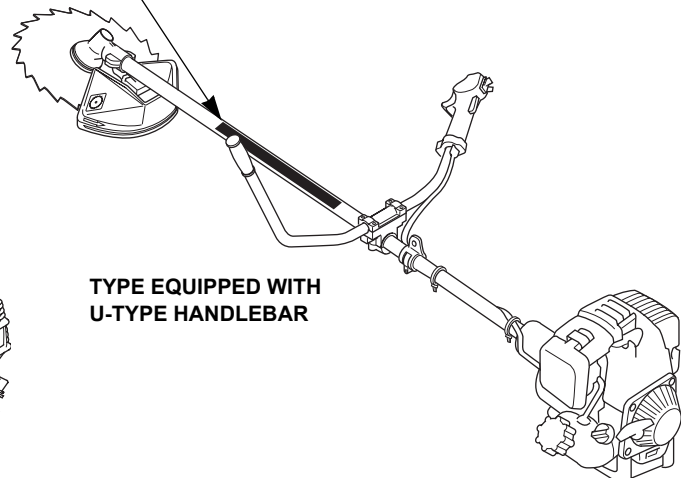

TYPE EQUIPPED WITH U-TYPE HANDLEBAR

RECOMMENDED CUTTING ATTACHMENTS

CUTTING-LINE HEADS AND SHIELDS

A cutting-line head containing nylon monofilament line, and a debris shield with cutoff knife is standard equipment. The shield's cutoff knife automatically removes any excess line that is released from the cutting head.

Honda HHT31SUNBA model trimmers are supplied with two different debris shields. Use the debris shield with the cutoff knife when the cutting-line head is installed.

Nylon monofilament line is suitable for cutting grass and ordinary weeds, but not brush and woody growth.

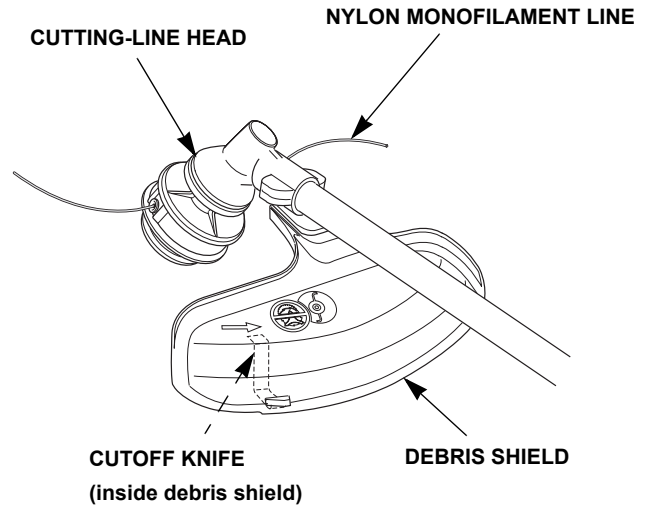

Manual-Feed Cutting-Line Head

Line is released from the cutting head by manually pulling and turning the spool with the trimmer engine stopped.

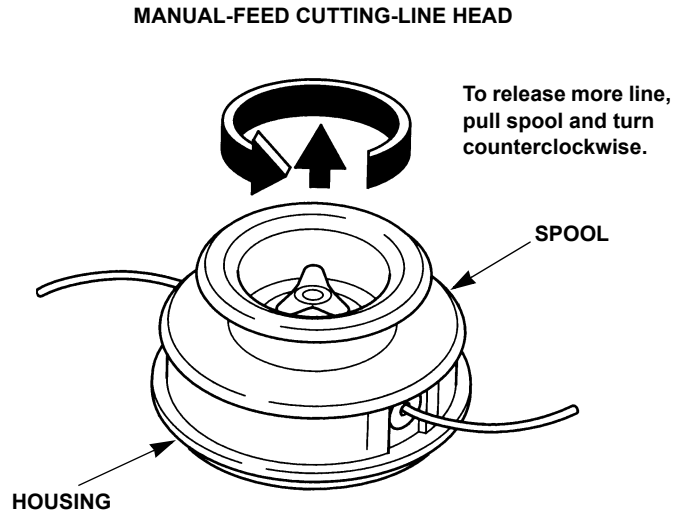

Semi-Matic (bump-feed) Cutting-Line Head

Line is released from the cutting head by bumping the spool on hard ground while head is spinning. Do not tap the cutting-line head on pavement or concrete.

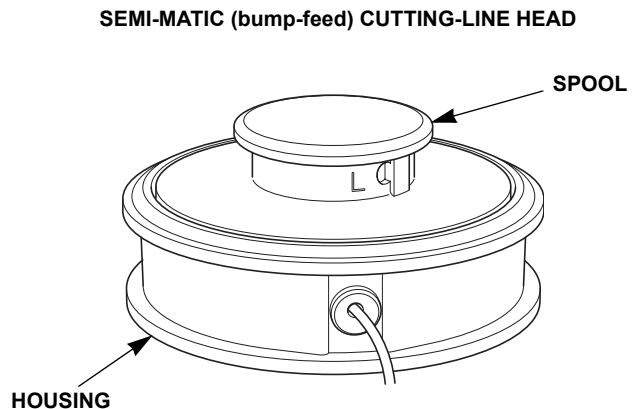

RECOMMENDED CUTTING ATTACHMENTS

BLADES AND SHIELDS

A variety of blades are available from your Honda trimmer servicing dealer. Always use a debris shield designed for use with a blade when attaching a blade to your trimmer. The blade type debris shield does not have a cutoff knife.

Honda HHT31SUNBA trimmers are supplied with a blade cover surrounding the edge of the blade. For safety, and to protect the blade, the cover should be installed whenever the trimmer is not in use.

If installing a metal blade on a Honda trimmer equipped with a loop handle, also install the optional barrier kit that includes a full shoulder harness, a barrier bar, and a debris shield for metal blades. Follow the installation instructions and safety information that comes with the kit.

Grass/Weed Blades

Grass/weed blades, which may be plastic or metal, are used as an alternative to nylon monofilament line for cutting grass and ordinary weeds.

However, blades should never be used for edging against solid surfaces.

Weed/Brush Blades

These metal blades have chisel-shaped teeth that are used for cutting through field grass, thick weeds, and light brush. They are not designed for sawing woody material. The teeth must be sharp for good results.

Brush/Wood Blades

These metal saw-tooth blades are used for sawing through saplings, shrubs and woody brush. The teeth must be sharp for good results. Brush/wood blades will also cut grass and weeds, but they are not efficient for that purpose.

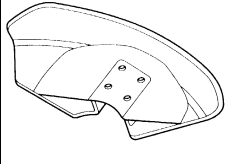
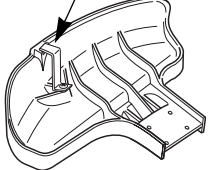
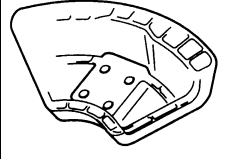
DEBRIS SHIELDS		
BLADE	CUTTING-LINE	
GRASS/WEED BLADE, WEED/BRUSH BLADE (optional part)		CUTOFF KNIFE 
BRUSH/WOOD BLADE		

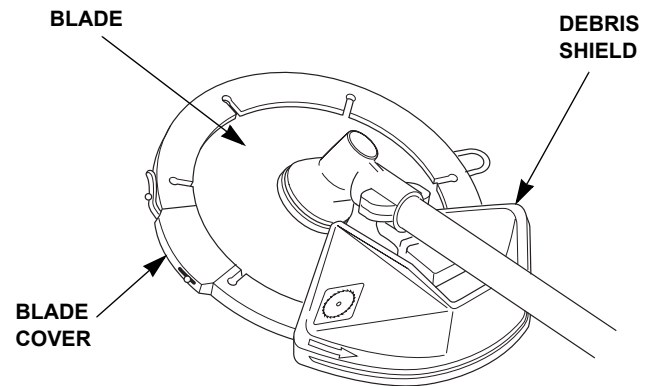

GRASS/WEED BLADE

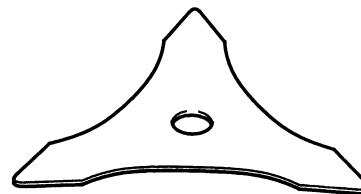

WEED/BRUSH BLADE

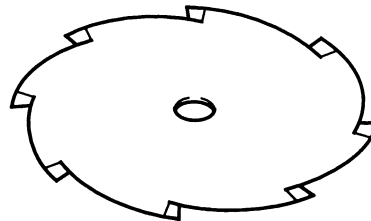

BRUSH/WOOD BLADE

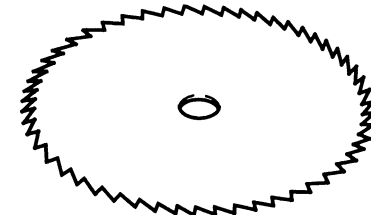

RECOMMENDED CUTTING ATTACHMENTS

Brush/Wood Blade Cover Installation and Removal

1. Install the blade cover over the blade so half the blade is covered.

To prevent the post end from interfering with the debris shield, pull the post end away from the blade and set it on top of the blade as shown.



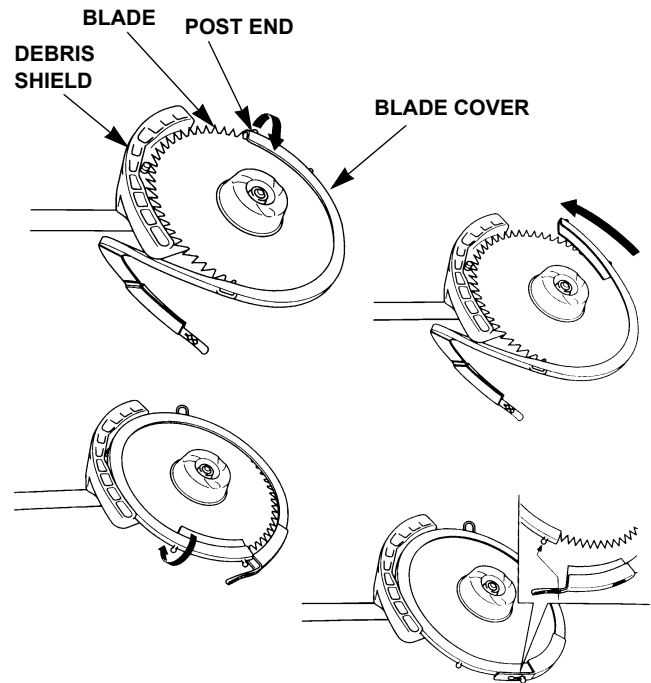

Turn the blade cover slowly until the post end clears the debris shield.

2. Reposition the post end over the blade.
3. With the blade cover fully seated on the blade, latch the tab over the post.

Remove the blade cover in the reverse order of installation.

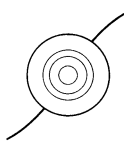
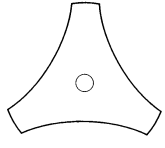
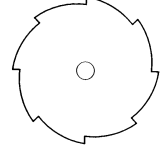
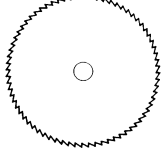

CUTTING ATTACHMENT APPLICATIONS

	Line Size	Blade Diameter		
HHT25S	0.095"	9"		
HHT31S	0.095" or 0.105"	9" or 10"		
				
GRASS AND LIGHT WEEDS 	OK	OK	OK	NO
THICK WEEDS AND LIGHT BRUSH 	NO	NO	OK	NO
WOODY BRUSH, SHRUBS, SAPLINGS 	NO	NO	NO	OK

Your Honda trimmer servicing dealer has cutting attachments that have been designed and approved for your trimmer and are covered by warranty. Non-Honda attachments are usually designed for universal applications. Although aftermarket attachments may fit on your trimmer, they may not meet factory specifications and could make your trimmer unsafe.

CONTROLS & EQUIPMENT

COMPONENT & CONTROL LOCATIONS

CUTTING-LINE HEAD

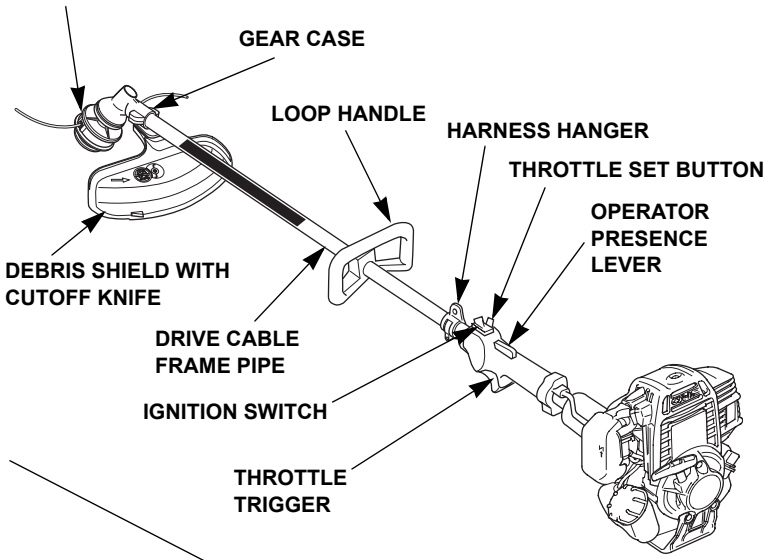

HHT25SLTA

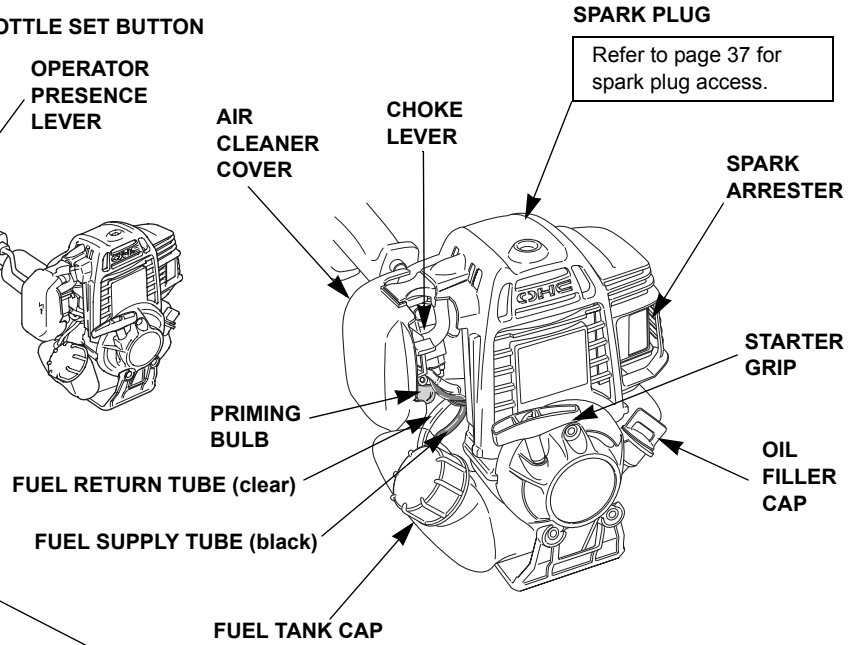

HHT31SLTA
HHT31SUNBA

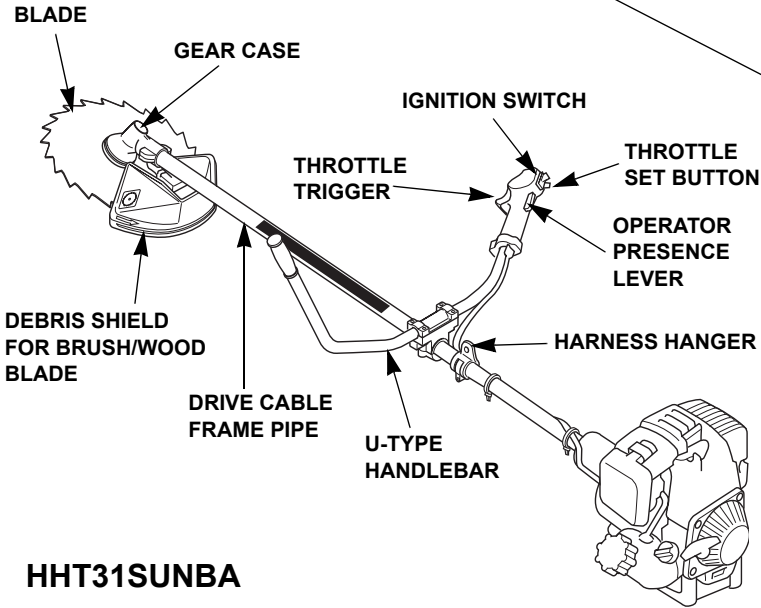

HHT31SUNBA

(supplied with a cutting-line head, a saw blade, and two debris shields)

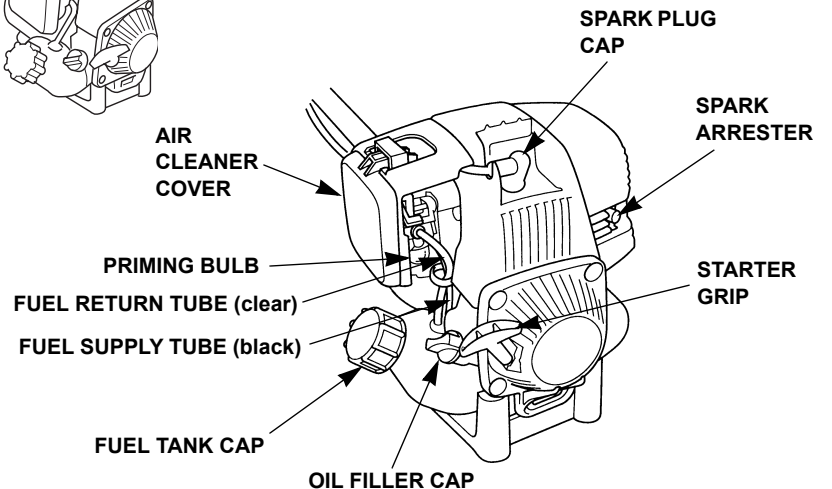
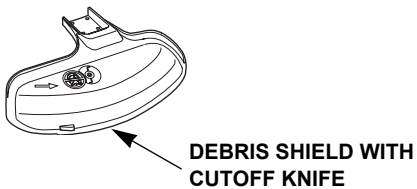
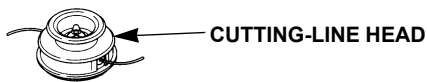

CONTROLS

The location and operation of the controls are similar on both the HHT25S and HHT31S models.

Choke Lever

The choke lever opens and closes the choke valve.

The CLOSED position enriches the fuel mixture for starting a cold engine.

The OPEN position provides the correct fuel mixture for operation after starting, and for restarting a warm engine.

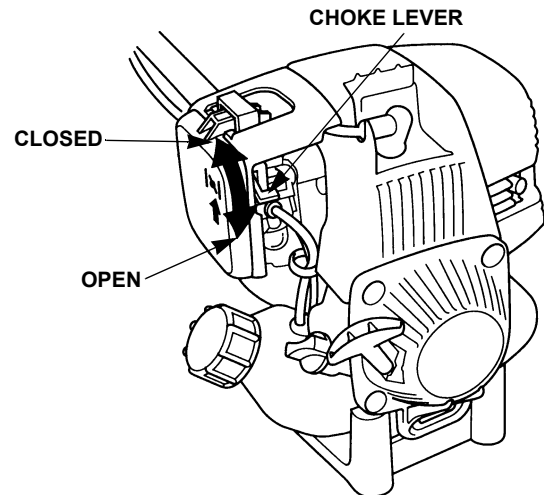

Ignition Switch

The ignition switch controls the ignition system.

The ignition switch must be in the ON (I) position for the engine to start and run.

Moving the ignition switch to the STOP (O) position stops the engine.

Operator Presence Lever

The operator presence lever blocks the throttle trigger. This safety feature prevents unintentional throttle operation if the trimmer is bumped while the operator's hand is not on the control handle.

When the operator presses the presence lever by gripping the control handle, the trigger moves freely.

Throttle Trigger

The throttle trigger controls engine speed.

Pulling the throttle trigger toward the control handle grip increases engine speed. The trimmer will have the greatest cutting force at maximum engine speed.

Releasing the throttle trigger reduces engine speed. At idle, the cutting attachment should coast to a stop.

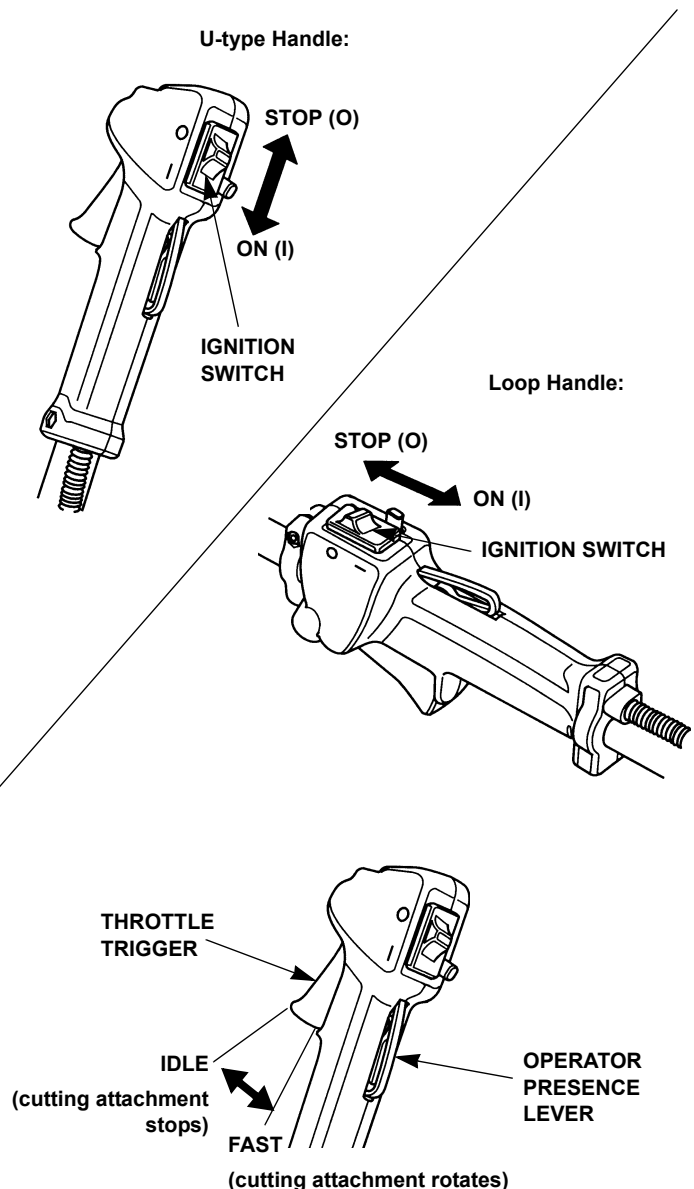

CONTROLS & EQUIPMENT

Throttle Set Button

The throttle set button is used to hold the throttle trigger at the fast idle position for starting. Do not allow the cutting line or blade to contact any obstruction when starting the engine with the throttle set button engaged.

To engage the throttle set button, press the operator presence lever by gripping the control handle, pull the throttle trigger, then press and hold the throttle set button while releasing the throttle trigger.

To disengage the throttle set button, simply pull the throttle trigger. The throttle set button automatically disengages when the throttle trigger is pulled.

Do not use the throttle set button while operating the trimmer. The trimmer will not return to idle, and the cutting-line head or blade will continue to spin until the throttle set button is disengaged and the throttle trigger is released.

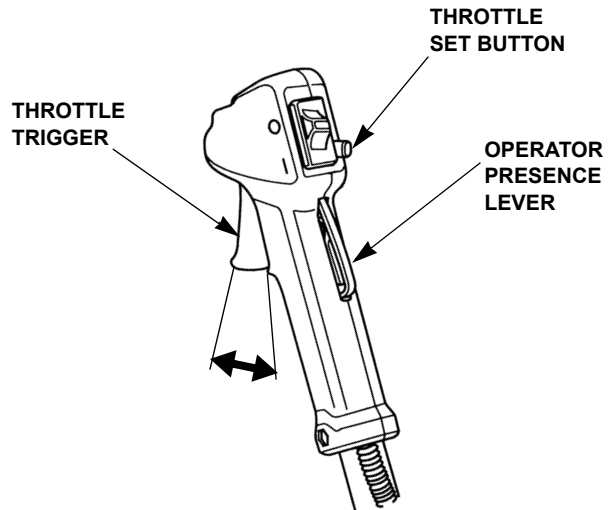

Priming Bulb

Pressing the priming bulb pumps fuel from the fuel tank to the carburetor. This procedure is necessary for starting the engine.

To ensure fuel has reached the carburetor, press the priming bulb repeatedly until fuel can be seen in the clear plastic fuel return tube.

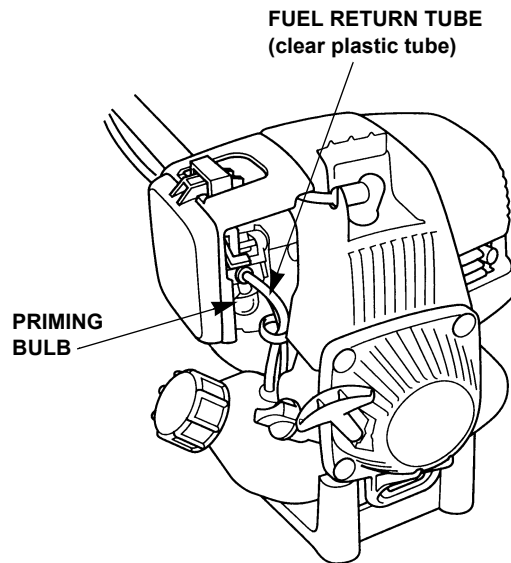

Recoil Starter Grip

Pulling the starter grip operates the recoil starter to turn the engine for starting.

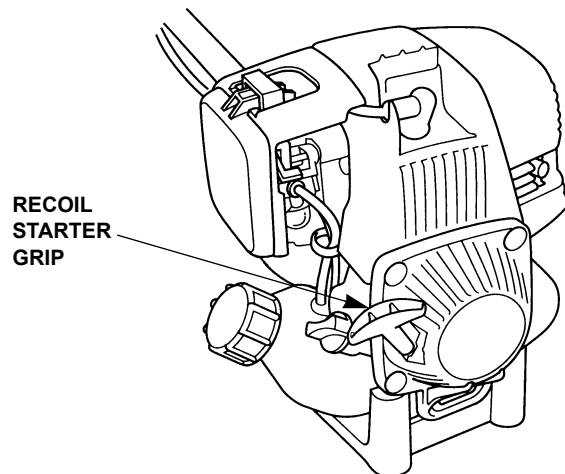

EQUIPMENT

The Honda HHT25S and HHT31S trimmer/brush cutters are supplied with a shoulder harness and safety glasses. Refer to page 14 for a description of other equipment and protective clothing you will need.

Shoulder Harness

A full shoulder harness must be worn by the operator of these Honda trimmers/brush cutters when equipped with a blade and debris shield. If the trimmer is equipped with a cutting-line head and shield with cutoff knife, the operator may wear a single-strap harness

A suitable shoulder harness is supplied with each new Honda HHT25S and HHT31S trimmer/brush cutter. Replacement shoulder harnesses may be purchased through any authorized Honda trimmer/brush cutter servicing dealer.

Before operation, adjust your shoulder harness as described on page 16.

Quick-Release Latch

The shoulder harnesses supplied with these trimmers are equipped with a quick-release latch.

Pull the latch tab upward to detach the trimmer from the harness.

Insert the latch tongue in the slot of the quick-release latch to reattach the trimmer to the harness.

Safety Glasses

Safety glasses or goggles that comply with ANSI (American National Standards Institute) standard Z87.1 must be worn by the operator of any Honda trimmer/brush cutter. The safety glasses supplied with each new Honda HHT25S and HHT31S trimmer/brush cutter complies with this ANSI standard.

FULL SHOULDER HARNESS (UNBA only)

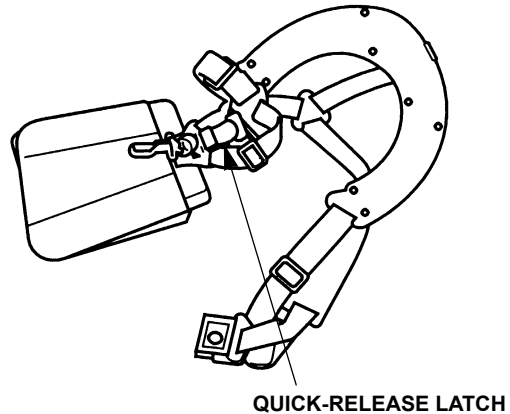

QUICK-RELEASE LATCH

SINGLE-STRAP SHOULDER HARNESS (LTA only)

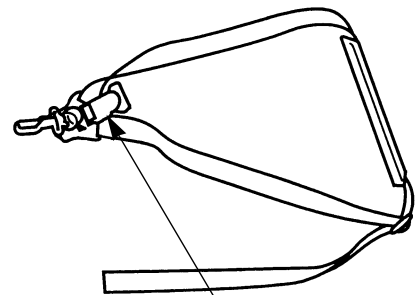

QUICK-RELEASE LATCH

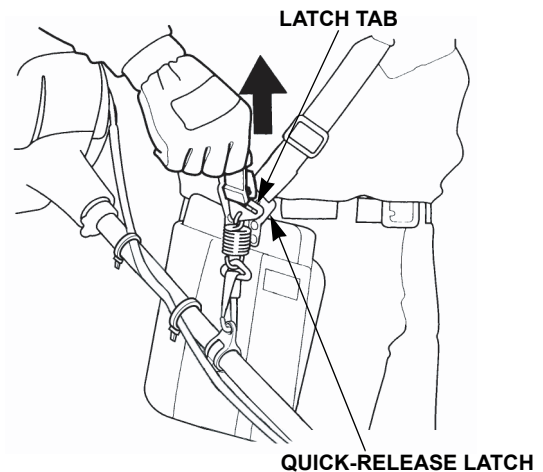

SAFETY GLASSES (ANSI Z87.1)

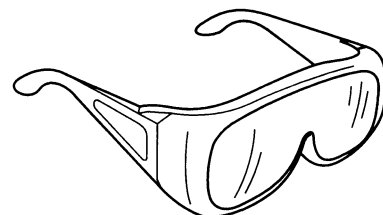

BEFORE OPERATION

ARE YOU READY TO OPERATE THE TRIMMER?

Your safety is your responsibility. A little time spent in preparation will significantly reduce your risk of injury.

Knowledge

Read and understand this manual. Know what the controls do and how to operate them.

Familiarize yourself with the trimmer and its operation before you begin to use it. Know what to do in case of emergencies.

Physical and Mental Readiness

You must be alert and in good physical condition to operate the trimmer. Do not operate the trimmer if you are tired, ill, or under the influence of alcohol, medication, or any substance that might impair your vision, dexterity, or judgment.

If you have any physical problem that may be aggravated by strenuous work, consult your physician before operating the trimmer.

Protective Clothing

Wearing protective clothing will reduce your risk of injury. Do not wear loose clothing, jewelry, short pants, sandals, or go barefoot. Secure hair so it is above shoulder level.

Eye, Face, and Head Protection

Always wear safety glasses or goggles that comply with ANSI standard Z87.1 to protect your eyes from thrown objects. Prescription glasses may be worn under the safety glasses or goggles.

A helmet with a face shield is recommended for further protection. However, safety glasses or goggles should always be worn under the face shield. Do not rely on a face shield alone to protect your eyes.

Wearing a dust mask will help to reduce the amount of pollens and dust inhaled.

Hearing Protection

Hearing protectors will help to protect your ears from noise. Earmuff-style hearing protectors can also protect your ears from thrown objects.

Hand and Body Protection

Wear gloves, a long-sleeved shirt, and long pants made of heavy material. Clothing should fit closely but allow freedom of movement, and should have no strings, straps, etc. that could catch on brush or the trimmer. Keep clothing fastened.

Foot Protection

Wear sturdy work boots with good toe protection and nonslip soles.

IS YOUR WORKING AREA READY?

Objects thrown by the trimmer can cause serious injury. Before operating the trimmer, carefully inspect the area and remove all objects that could be thrown by, or entangled in, the cutting attachment, such as rocks, broken glass, nails, wire, or string.

Clear the area of children, bystanders, and pets. Keep all children, bystanders, and pets at least 50 feet (15 meters) away from where the trimmer is being operated.

Even outside a 50-foot (15-meter) radius of the trimmer, there may be a risk of injury from thrown objects, so bystanders should be encouraged to wear eye protection.

If anyone approaches you while you are operating the trimmer, release the throttle trigger and stop the engine.

IS YOUR TRIMMER READY TO GO?

For your safety, and to maximize the service life of your equipment, it is very important to take a few moments before you operate the trimmer to check its condition. Be sure to take care of any problem you find, or have your servicing dealer correct it, before you operate the trimmer.

⚠ WARNING

Improperly maintaining this trimmer, or failing to correct a problem before operation, could cause a malfunction in which you could be seriously injured.

Always perform a preoperation inspection before each operation, and correct any problem.

Safety Inspection

- Look around the engine for signs of oil or gasoline leaks. Wipe up any spills before starting the engine.
- Replace any damaged parts.
- Check that all fasteners are in place and secure. Tighten as necessary.

Cutting Attachment Inspection

- Look for signs of damage to the cutting attachment (see pages 29 and 35). Replace any cutting attachment and parts that are worn out, bent, cracked, chipped, or damaged in any way.
- If using a metal blade, be sure it is sharp. A dull blade is more likely to snag and thrust.
- If using a metal blade on a trimmer equipped with a loop handle, be sure the barrier bar (optional part) is installed beneath the loop handle.
- Make sure the cutting attachment is properly installed and securely fastened (see pages 34 and 36).
- Check that the debris shield is the correct shield for the cutting attachment (see page 36), and that it is securely installed and in good condition.

Maintenance Inspection

- Check the oil level (see page 26). Running the engine with a low oil level can cause engine damage.
- Check the air filter (see page 27). A dirty air filter will restrict air flow to the carburetor, reducing engine and trimmer performance.
- Check throttle cable free play (see page 28). The cable must be correctly adjusted and operate smoothly for good throttle control.
- Check the fuel level (see page 40). Starting with a full tank will help to eliminate or reduce operating interruptions for refueling.

BEFORE OPERATION

ARE YOUR SHOULDER HARNESS AND TRIMMER CORRECTLY ADJUSTED?

Adjusting the Harness

Adjust the harness so the quick-release latch is at your right hip, as shown.

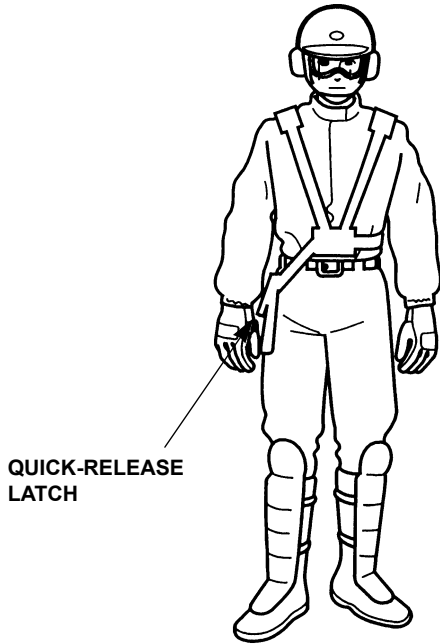

FULL SHOULDER HARNESS

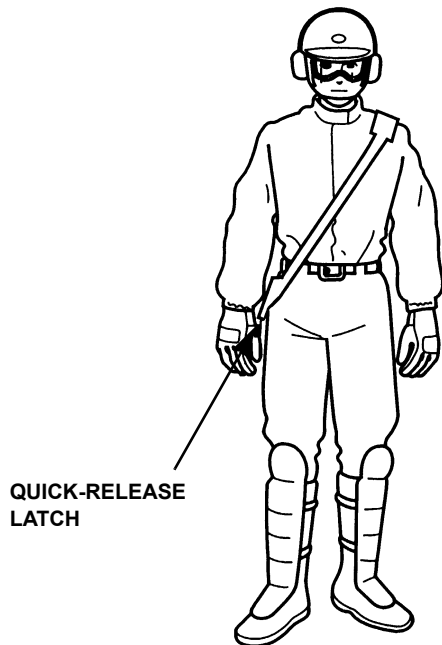

SINGLE-STRAP SHOULDER HARNESS

Balancing the Trimmer on the Shoulder Harness

Hang the trimmer on the harness hook, and see how it balances.

Adjust the shoulder harness, the harness hanger on the frame pipe, and the loop handle or U-type handlebar, so the handle or handlebars are in a comfortable operating position, and the trimmer hangs with its cutting attachment a few inches above the ground (see page 19).

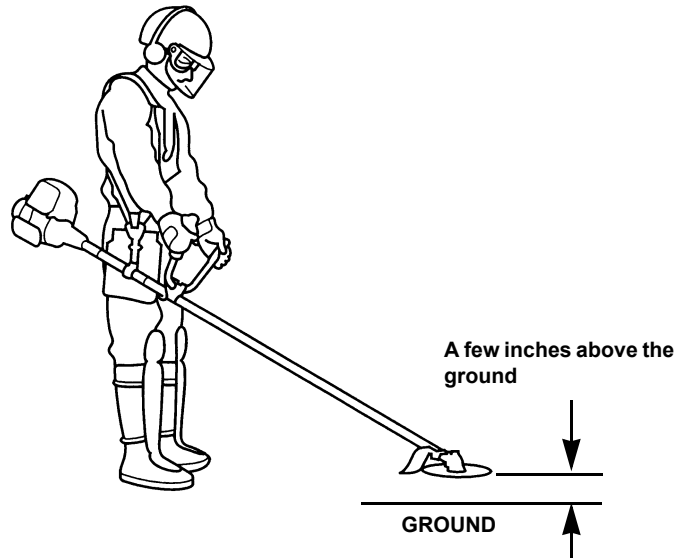

OPERATION

SAFE OPERATING PRECAUTIONS

Before operating the trimmer for the first time, please review the *IMPORTANT SAFETY INFORMATION* chapter on page 4 and *BEFORE OPERATION* chapter starting on page 14.

Even if you have operated other trimmers, take time to become familiar with the operation of this trimmer's controls and handling.

For your safety, avoid starting or operating the engine in an enclosed area, such as a garage. Your engine's exhaust contains poisonous carbon monoxide gas which can collect rapidly in an enclosed area and cause illness or death.

If the trimmer starts to shake or vibrate, stop the engine immediately. After the cutting head has completely stopped, inspect it to determine the cause of the vibration. Sudden vibration is a sign of a hazardous problem, such as a loose or damaged blade. Do not operate the trimmer until the problem is corrected.

Prolonged exposure to vibration may cause vibration syndrome (Raynaud's disease). Symptoms include loss of skin color in the hands and numbness or a painful tingling sensation in the fingers, hands, and arms. Regular users of any power equipment may feel the numbness or pain spontaneously, at any time, not just after using the equipment. If any of these symptoms occur, see a physician immediately.

STARTING THE ENGINE

1. To start a cold engine, move the choke lever to the CLOSED position.

To restart a warm engine, leave the choke lever in the OPEN position.

2. To start a cold engine, or after refueling an engine that has run out of fuel, press the priming bulb repeatedly until fuel can be seen in the clear plastic fuel return tube.

To restart a warm engine, it is not necessary to press the priming bulb.

3. Set the throttle trigger in the starting position, using the throttle set button.

To set the throttle trigger for starting, press the operator presence lever by gripping the control handle, pull the throttle trigger, then press and hold the throttle set button while releasing the throttle trigger.

4. Move the ignition switch to the ON (I) position.

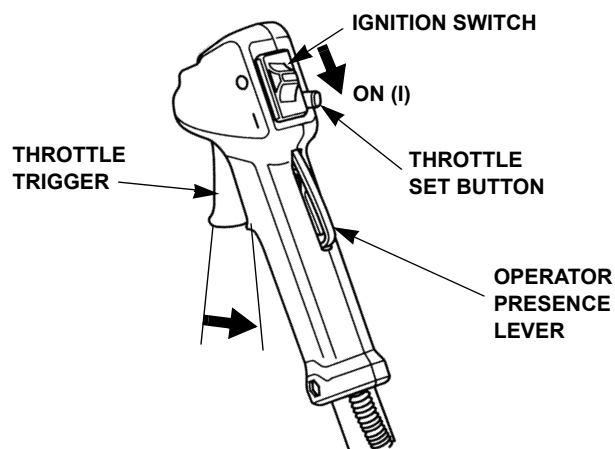
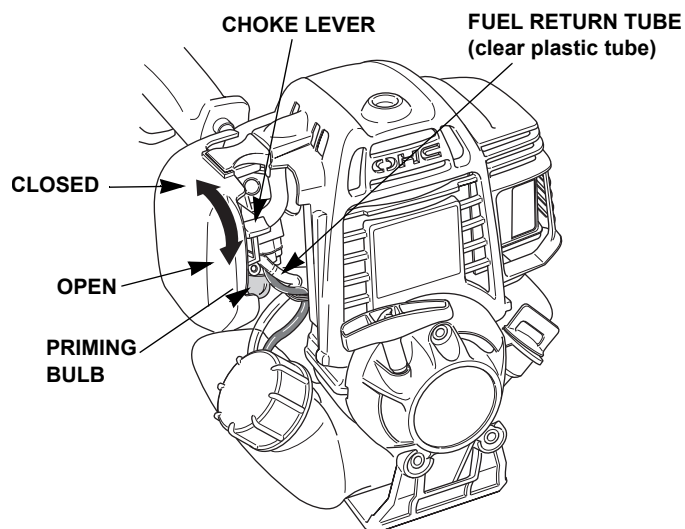

OPERATION

5. Set the trimmer on the ground, resting on the debris shield and the fuel tank guard. Do not allow the cutting-line or blade to contact any obstruction.

Always rest the trimmer on the ground for starting, rather than holding it in the operating position. This prevents the end of the trimmer from swinging into something as you start the engine.

6. With your left hand, hold the frame pipe just ahead of the engine. With your right hand, pull the starter grip lightly until you feel resistance, then pull briskly. Return the starter grip gently.



7. If the choke lever was moved to the CLOSED position to start the engine, gradually move it to the OPEN position as the engine warms up.

Allow the engine to warm up for a few minutes after a cold start. When the engine is warm enough to idle well, pull and release the throttle trigger to disengage the throttle set button.

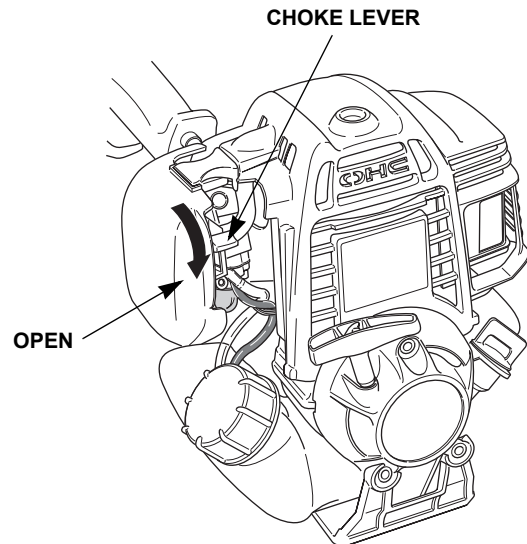

8. With the engine idling, hook the trimmer to your shoulder harness. Be careful to avoid contact with the cutting-line head or blade while handling the trimmer with the engine running.

The cutting-line head or blade should not rotate with the engine idling. If there is rotation at idle, adjust the idle speed correctly before using the trimmer. For idle adjustment, consult your authorized Honda servicing dealer.

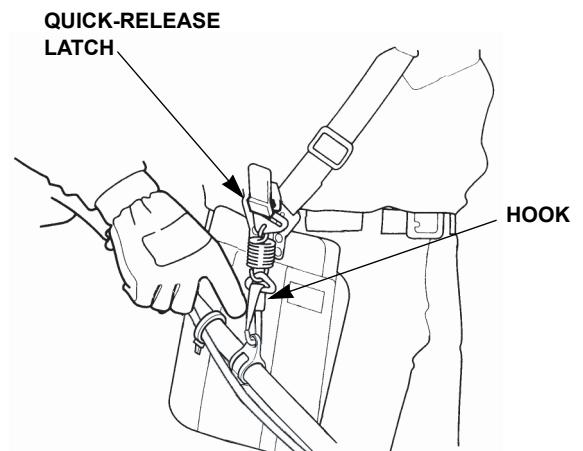

STOPPING THE ENGINE

1. Release the throttle trigger.
2. Move the ignition switch to the STOP (O) position.

Wait for the cutting line head or blade to stop before allowing the end of the trimmer to contact anything.

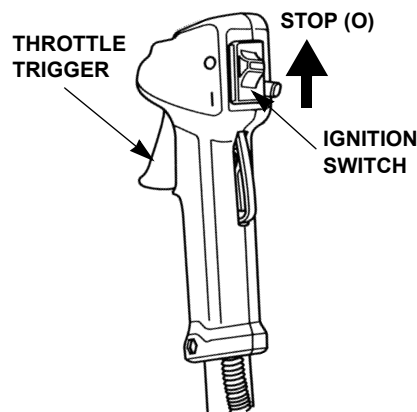

⚠ WARNING

The blade will continue to spin briefly after the engine has stopped or the throttle trigger is released.

A coasting blade can cause injury.

Maintain proper control of the trimmer until the blade has completely stopped rotating.

TRIMMER/HARNESS QUICK DISCONNECTION

To quickly detach the trimmer from the harness, pull the quick-release latch tab upward.

Insert the latch tongue in the slot of the quick-release latch to reattach the trimmer to the harness.

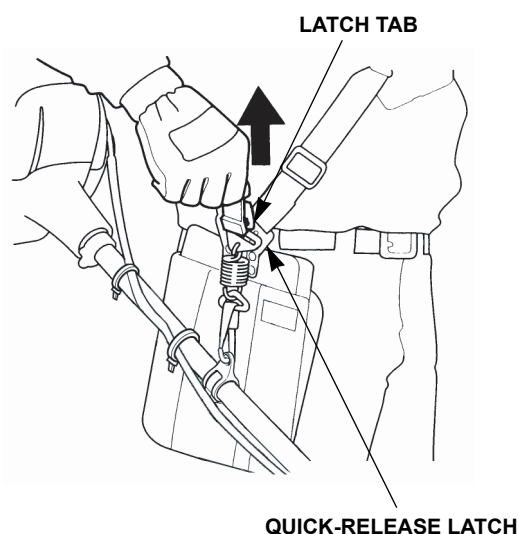

TRIMMER OPERATION

Operating Position

Hold the trimmer firmly with both hands, with your fingers and thumbs encircling the handles as shown. This will help you to keep the trimmer under control at all times.

- Keep firm footing and balance.
- Do not overreach.
- Keep the cutting attachment below waist level.
- Keep all parts of your body away from the rotating cutting attachment and hot surfaces.



OPERATION

Throttle Operation

Pull the throttle trigger toward the grip to increase engine speed and start cutting attachment rotation.

The trimmer has the greatest cutting force at maximum engine speed.

Release the throttle trigger to reduce engine speed. At idle, the cutting attachment should coast to a stop.

Using a Nylon Cutting-Line Head

As the ends of the line wear away, more line must be released from the cutting-line head. Your trimmer is factory-equipped with either a manual-feed or a semi-matic (bump feed) cutting-line head, which have different procedures for releasing line.

The debris shield is equipped with a cutoff knife which automatically removes any excess line that is released.

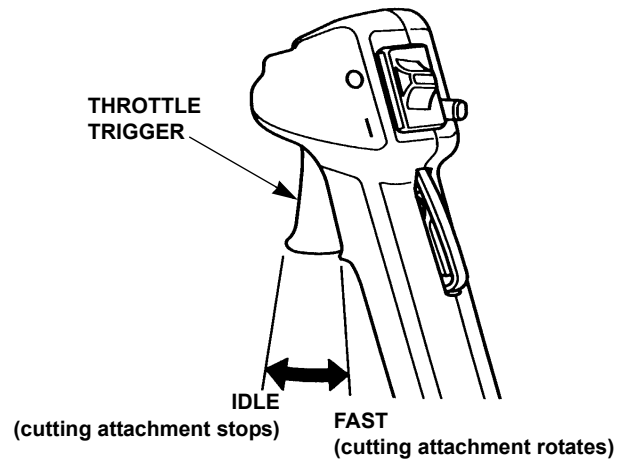

Manual-Feed Cutting-Line Head

Line must be released with the cutting-line head stopped.

1. Stop the engine, and wait for the cutting-line head to coast to a complete stop.
2. Hold the housing, pull the spool out about a quarter of an inch, then turn the spool counterclockwise until it snaps into the housing again.

The spool will snap into the housing every sixth of a turn, which releases 1 to 1-1/2 inches of line.

MANUAL-FEED CUTTING-LINE HEAD

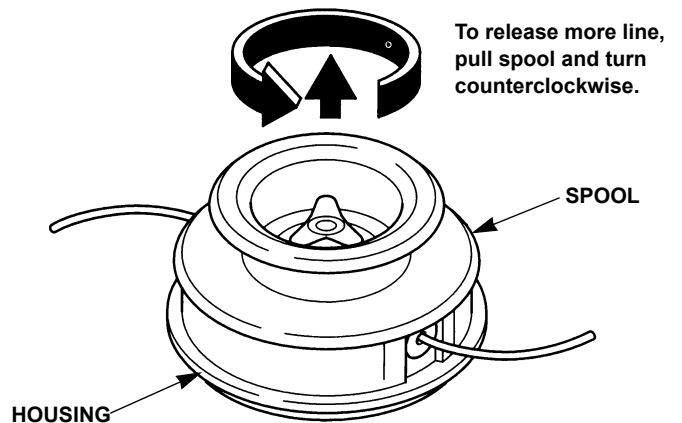

Semi-Matic (bump-feed) Cutting-Line Head

Line must be released with the cutting-line head spinning rapidly.

With the engine running at full speed, tap the cutting-line head on hard, bare ground. Do not tap the cutting-line head on pavement or concrete.

Each tap releases about 2 inches of line.

SEMI-MATIC (bump-feed) CUTTING-LINE HEAD

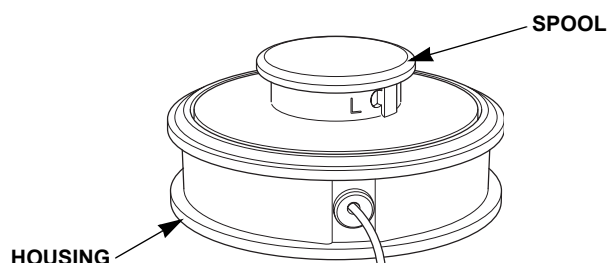

Using Blades

Refer to the chart on page 9 for appropriate blade applications.

If using a blade on a Honda trimmer equipped with a loop handle, also install the optional Honda conversion kit that includes a full shoulder harness, a barrier bar, and a debris shield for blades. Follow the installation instructions and safety information that come with the kit.

Metal blades supplied with UNBA models are supplied with a cover surrounding the edge of the blade. For your safety, and to protect the blade, the cover should be installed whenever the trimmer is not in use.

Be sure to remove the blade cover before starting the engine. Otherwise, the blade cover may fly off at high speed.

If the trimmer starts to vibrate after the blade strikes an object, stop the engine immediately and check the blade for damage. A damaged blade may break, and pieces of broken blade can become dangerous projectiles. Replace the blade if it is broken, cracked, bent, or damaged in any way.

SAFE OPERATING PRACTICES

Be very careful when operating the trimmer over uneven or rough ground, and when the ground is wet and slippery. Watch out for hidden obstacles that could cause you to stumble. Operate the trimmer only under conditions with good visibility. Do not operate the trimmer where you cannot see what it is cutting.

⚠ WARNING

Rotating cutting lines can cause serious abrasions and cuts, and blades can cut deeply.

- Keep away from the cutting lines or blade whenever the engine is running.
- Always stop the engine, and be sure the cutting line head has stopped turning, before inspecting or handling the cutting lines or blade.

Thrown Debris

The trimmer will throw debris in the direction of blade movement at the point of contact.

The cutting line head or blade on Honda HHT25S and HHT31S trimmers rotate counterclockwise, as viewed from the operator's position, so tilting the cutting line head to the right will throw debris away from you, and tilting to the left will throw debris toward you.

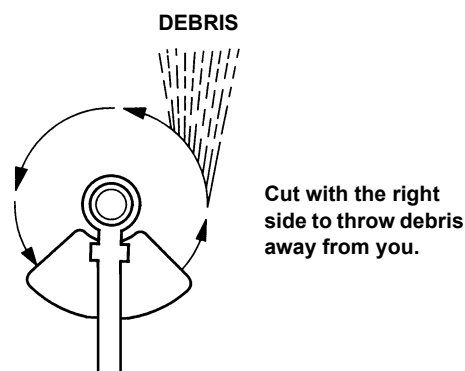

If the cutting line head or blade is held parallel to the ground, debris will scatter in all directions, and there will be greater friction which will wear out the cutting line or blade sooner.

When operating the trimmer near a hard surface such as a wall, work from an angle where debris that strikes the hard surface will ricochet away from you.

Gravel, loose stones, etc. can be picked up by the nylon cutting lines or blade and thrown many feet with enough force to cause serious personal injury and/or property damage. Before crossing graveled areas, release the throttle trigger to stop the cutting line head or blade.

OPERATION

Blade Thrust (Kickback)

Blade thrust (kickback) is the sudden, forceful, and uncontrolled movement of a blade-equipped trimmer that may occur if the blade binds in the cut or strikes a solid object.

Blade thrust (kickback) throws the trimmer in the direction opposite blade rotation at the point of contact, and the jolt received by the operator can result in further loss of control.

To reduce the risk of loss of control, use metal blades on trimmers equipped with a U-type handlebar, or install the barrier bar (optional part) on trimmers equipped with a loop handle.

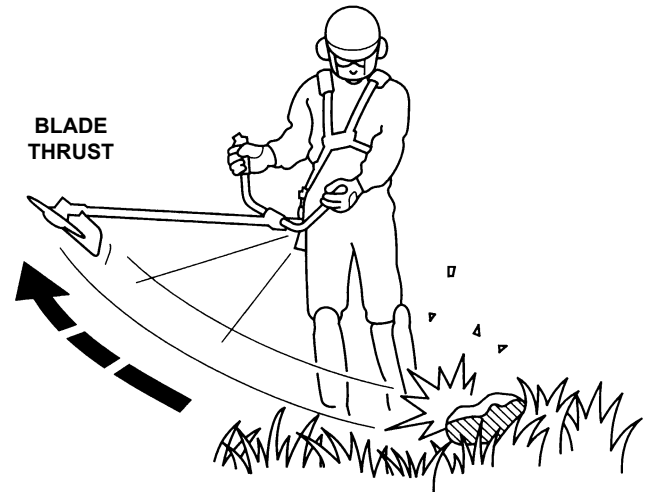

Replace or resharpen dull blades. Dull blades are more likely to bind in the cut and cause blade thrust.

Watch out for hidden obstacles, such as rocks, stumps, roots, etc., that could cause the blade to kick back if struck. Blade thrust is more likely to occur in areas where it is difficult to see what is being cut.

Understand the reaction forces of the blade. When using a brush blade to saw through heavy brush and small saplings, saw with the side of the brush blade that is moving toward you and tends to pull the trimmer away from you.

Blades on Honda HHT25S and HHT31S trimmers rotate counterclockwise, as viewed from the operator's position. Therefore, the left side of the blade is moving toward you. With these trimmers, sawing with the left side of a brush blade will give you better control and less risk of kickback, though it will throw the sawdust toward you.

Cut from the side of saplings that will cause them to fall away from the trimmer. This will help prevent the blade from binding in the cut and kicking back.

Accelerate the engine to maximum speed before starting the cut, and saw through with uniform pressure.

OPERATING TIPS

Scything

Swing the trimmer in a level arc by rotating your body with a smooth, easy motion, rather than moving the trimmer with your arms. Do not chop at tough weeds and brush; let the cutting line or blade work through tough growths gradually.

To direct thrown debris away from you, tilt the cutting attachment to the right side, scythe from left to right, then return without cutting.



Trimming and Edging

Use nylon line for cutting against a hard surface. Work from an angle where debris that strikes the hard surface will ricochet away from you.

Avoid contact with wires, wire fences, metal rods, etc. Overlapping a wire will cause the nylon line to wrap around the wire and break off.

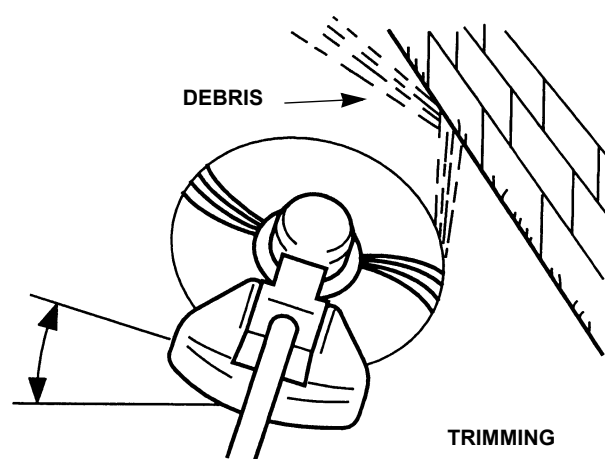

Brush Clearing

Clearing brush with a brush blade may require both scything and sawing.

Scything with the right side of the blade will direct thrown debris away from you.

Be especially careful to direct debris away from you if recutting an area to shorten stumps. Short lengths of shrub and sapling stumps may tear off and be thrown at high speed.

Sawing heavy brush and saplings with the left side of the blade will reduce the risk of kickback.

Accelerate the engine to maximum speed before starting the cut, and saw through with uniform pressure.

If shrubs or saplings bind the blade, stop the engine, and while supporting the weight of the trimmer, push the shrub or sapling away to free the blade. Do not use the blade as a lever.



Operation on Slopes

Start on the low side of a slope, and work upward. This will reduce your risk of slipping and falling, and it will give you a cutting angle that will better enable you to direct debris away from you.

Do not let the cutting line or blade dig into the slope, because that can cause stones and dirt to be thrown at you.

Do not raise the cutting attachment above waist level during operation, because that would increase the risk of thrown objects striking your face.

Avoid steep slopes that would require holding the cutting attachment above waist level. Avoid slippery slopes that might cause you to lose your balance.

SERVICING YOUR HONDA TRIMMER

THE IMPORTANCE OF MAINTENANCE

Good maintenance is essential for safe, economical, and trouble-free operation. It will also help reduce air pollution.

WARNING

Improperly maintaining this trimmer, or failure to correct a problem before operation, can cause a malfunction in which you can be seriously hurt or killed.

Always follow the inspection and maintenance recommendations and schedules in this owner's manual.

To help you properly care for your trimmer, the following pages include a maintenance schedule, routine inspection procedures, and simple maintenance procedures using basic hand tools. Other service tasks that are more difficult, or require special tools, are best handled by professionals and are normally performed by a Honda technician or other qualified mechanic.

The maintenance schedule applies to normal operating conditions. If you operate your trimmer under severe conditions, such as sustained high-load or high-temperature operation, or use it in unusually wet or dusty conditions, consult your authorized Honda servicing dealer for recommendations applicable to your individual needs and use.

Remember that your authorized Honda servicing dealer knows your trimmer best and is fully equipped to maintain and repair it.

To ensure the best quality and reliability, use only new, genuine Honda parts or their equivalents for repair and replacement.

Maintenance, replacement, or repair of the emission control devices and systems may be performed by any engine repair establishment or individual, using parts that are “certified” to EPA standards.

MAINTENANCE SAFETY

Some of the most important safety precautions follow. However, we cannot warn you of every conceivable hazard that can arise in performing maintenance. Only you can decide whether or not you should perform a given task.

WARNING

Failure to properly follow maintenance instructions and precautions can cause you to be seriously hurt or killed.

Always follow the procedures and precautions in the owner's manual.

Safety Precautions

- Make sure the engine is off before you begin any maintenance or repairs. This will eliminate several potential hazards:
 - **Carbon monoxide poisoning from engine exhaust.**
Be sure there is adequate ventilation whenever you operate the engine.
 - **Burns from hot parts.**
Let the engine and exhaust system cool before touching.
 - **Injury from moving parts.**
Do not run the engine unless instructed to do so.
- Read the instructions before you begin, and make sure you have the tools and skills required.
- To reduce the possibility of fire or explosion, be careful when working around gasoline. Use only a nonflammable solvent, not gasoline, to clean parts. Keep cigarettes, sparks, and flames away from all fuel-related parts.

SERVICING YOUR HONDA TRIMMER

MAINTENANCE SCHEDULE

REGULAR SERVICE PERIOD (3)		Before each use	First month or 10 Hrs	Every 3 months or 25 Hrs	Every 6 months or 50 Hrs	Every year or 100 Hrs	Every 2 years or after each 300 Hrs	Refer to page
ITEM	Perform at every indicated month or operating hour interval, whichever comes first.							
Engine oil	Check	O						26
	Change		O		O			
Air filter	Check	O						27
	Clean			O(1)				
Throttle cable	Check	O						28
Cutting attachment	Check	O						29 ~ 36
Debris shield	Check	O						29 ~ 36
Nuts, bolts, fasteners	Check (Retighten if necessary)	O						—
Shoulder harness quick-release	Check	O						19
Drive cable	Check-Lubricate				O(2)			—
Idle speed	Check-Adjust					O(2)		—
Valve clearance	HHT25S Check-Adjust					O(2)		—
	HHT31S Check-Adjust						O(2)	
Spark plug	Check-Clean					O		37
	Replace						O	
Spark arrester	Check					O		38
Combustion chamber	Clean						O(2)	—
Gear case	Lubricate				O(2)			—
Clutch shoes and drum	Check				O(2)			—
Fuel filter	Check					O		41
Fuel tank	Clean					O		41
Fuel tubes	Check	Every two years [replace if necessary (2)]						—
Oil tube (HHT25S only)	Check	Every two years [replace if necessary (2)]						—
Engine cooling fins	Check				O			41

(1) Service more frequently when used in dusty areas.

(2) These items should be serviced by your servicing dealer, unless you have the proper tools and are mechanically proficient. Refer to the Honda shop manual for service procedures.

(3) Log hours of operation to determine proper maintenance intervals.

SERVICING YOUR HONDA TRIMMER

ENGINE

Engine Oil Level Check

Check the engine oil level before each use, or every 10 hours if operated continuously. Rest the trimmer on a level surface, with the engine stopped and in an upright position.

1. Remove the filler cap/dipstick and wipe it clean.
2. Insert and remove the dipstick without screwing it into the filler opening. Check the oil level shown on the dipstick.
3. If the oil level is low, fill to the edge of the oil filler hole with the recommended oil (see page 27). To avoid overfilling or underfilling, be sure the engine is in a level position, as shown.

NOTICE

Running the engine with too little or too much oil can cause engine damage.

4. Screw in the oil filler cap/dipstick securely.

Engine Oil Change

Drain the used oil while the engine is warm. Warm oil drains quickly and completely.

1. Place a suitable container below the engine to catch the used oil, then remove the filler cap/dipstick and drain the used oil through the filler opening. Allow the used oil to drain completely.

NOTICE

Improper disposal of engine oil can be harmful to the environment. If you change your own oil, please dispose of the used oil properly. Put it in a sealed container, and take it to a recycling center. Do not discard it in a trash bin or dump it on the ground.

2. With the engine in an upright position, fill to the edge of the oil filler hole with the recommended oil (see page 27).

Engine oil capacity: HHT25S 2.7 fl oz (80 cc)
HHT31S 3.4 fl oz (100 cc)

3. Screw in the filler cap/dipstick securely.

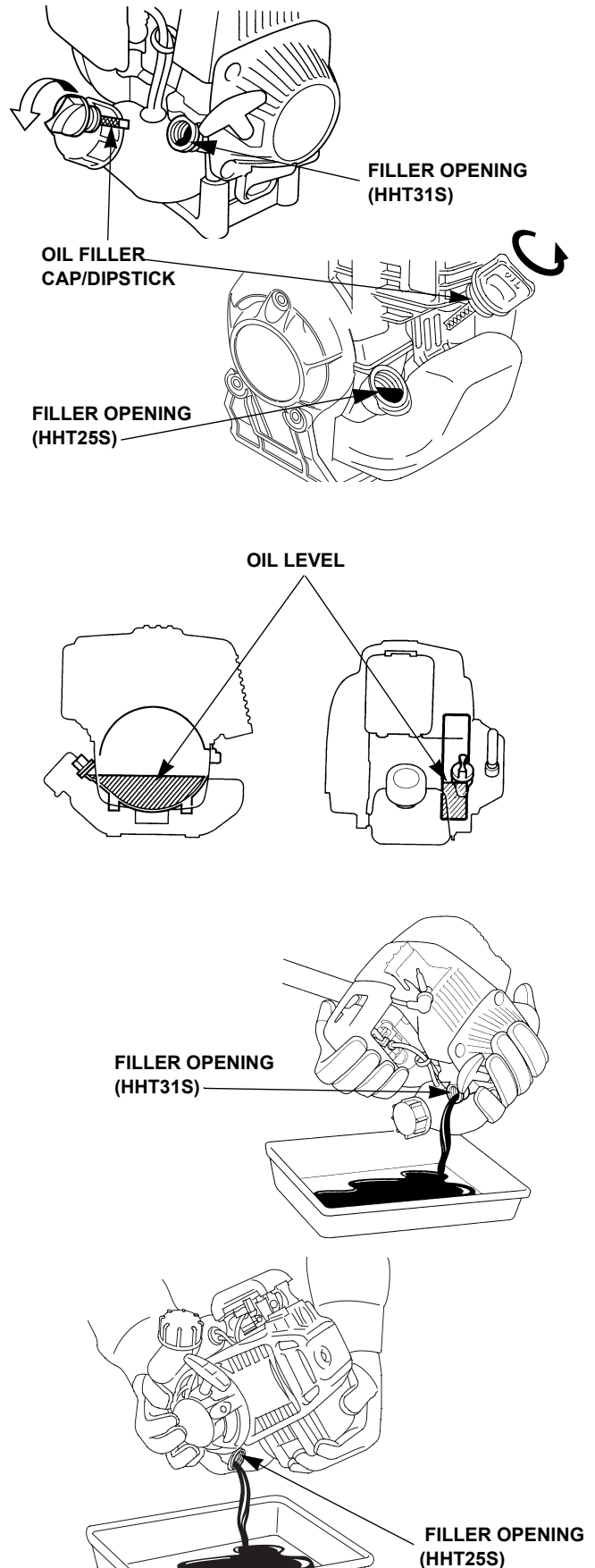

SERVICING YOUR HONDA TRIMMER

Engine Oil Recommendations

Oil is a major factor affecting performance and service life. Use 4-stroke automotive detergent oil.

SAE 10W-30 is recommended for all temperatures within the recommended operating range for these trimmers. The recommended operating range extends from 23°F (-5°C) to 104°F (40°C).

The SAE oil viscosity and service classification are on the API label on the oil container. Honda recommends that you use API SERVICE category SJ or SL oil.

Air Filter Check

Press the air cleaner latch tab, and remove the air cleaner cover. Check the filter to be sure it is clean and in good condition.

If the filter is dirty, clean it as described under *Air Filter Cleaning*. Replace the filter if it is damaged. Reinstall the filter and air cleaner cover.

NOTICE

Operating the engine without an air filter, or with a damaged air filter, will allow dirt to enter the engine, causing rapid engine wear. This type of damage is not covered by the Distributor's Limited Warranty.

Air Filter Cleaning

A dirty air filter will restrict air flow to the carburetor, reducing engine performance. If you operate the engine in very dusty areas, clean the air filter more often than specified in the MAINTENANCE SCHEDULE.

1. Clean the air filter in warm soapy water, rinse, and allow to dry thoroughly. Or clean in non-flammable solvent and allow to dry.
2. Dip the air filter in clean engine oil, then squeeze out all excess oil. The engine will smoke when started if too much oil is left in the filter.
3. Wipe dirt from the air cleaner base and cover using a moist rag. Be careful to prevent dirt from entering the carburetor.

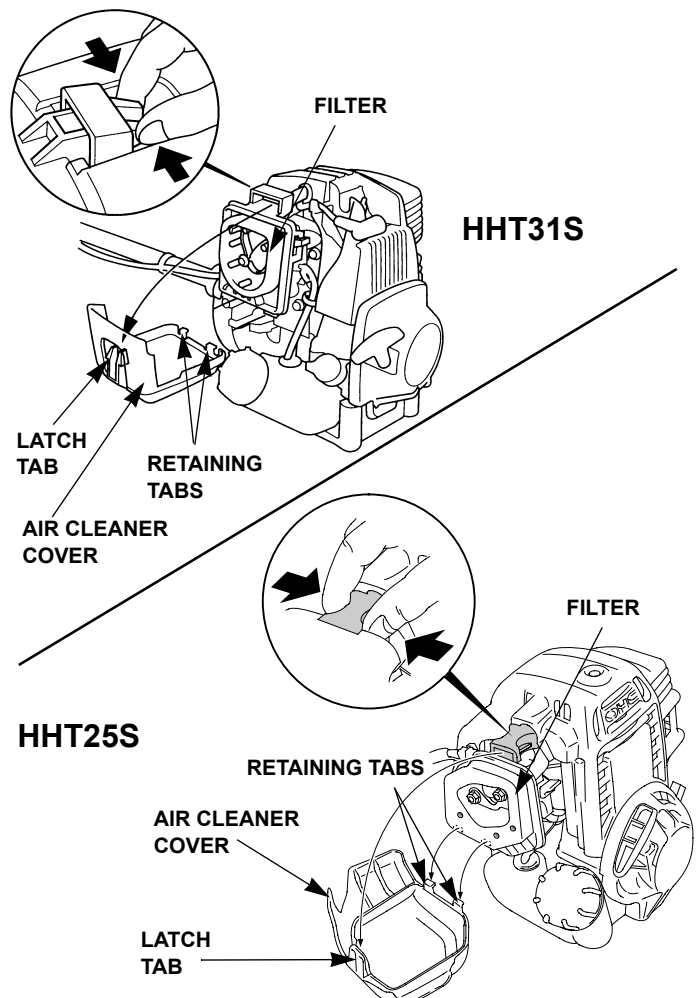

SERVICING YOUR HONDA TRIMMER

Throttle Cable Inspection

Verify the throttle trigger operates smoothly and the throttle cable is undamaged. If there is visible damage, or if the throttle trigger does not operate smoothly, have your authorized Honda servicing dealer replace the throttle cable.

Check the free play at the end of the throttle cable.

Free play (all models): 1/16 ~ 1/8 in (1.0 ~ 3.0 mm)

If adjustment is needed, use the following cable adjustment procedure.

Throttle Cable Adjustment

1. Loosen the lock nut with a 10 mm wrench, and turn the adjusting nut in or out as required.
2. Tighten the lock nut and recheck cable free play.

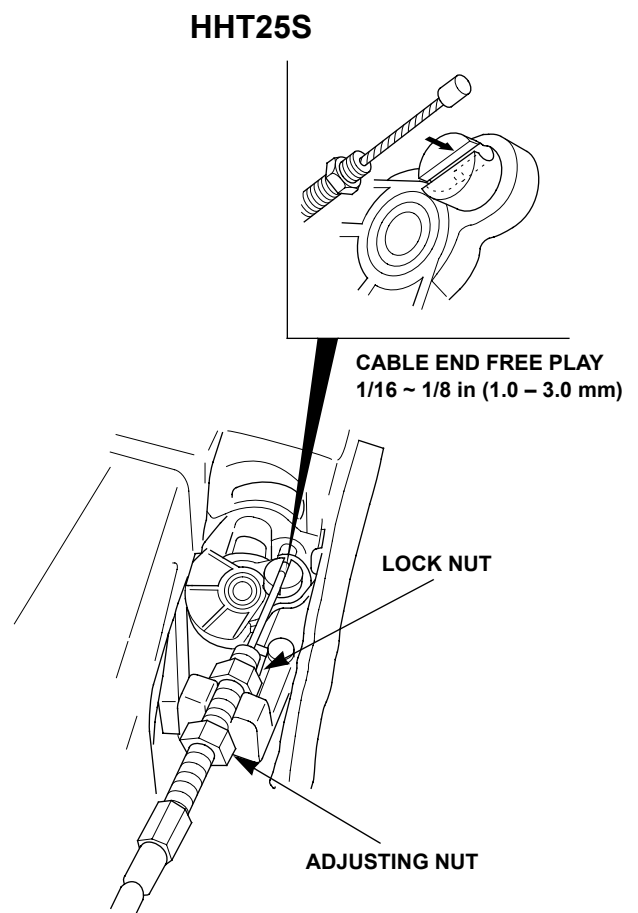
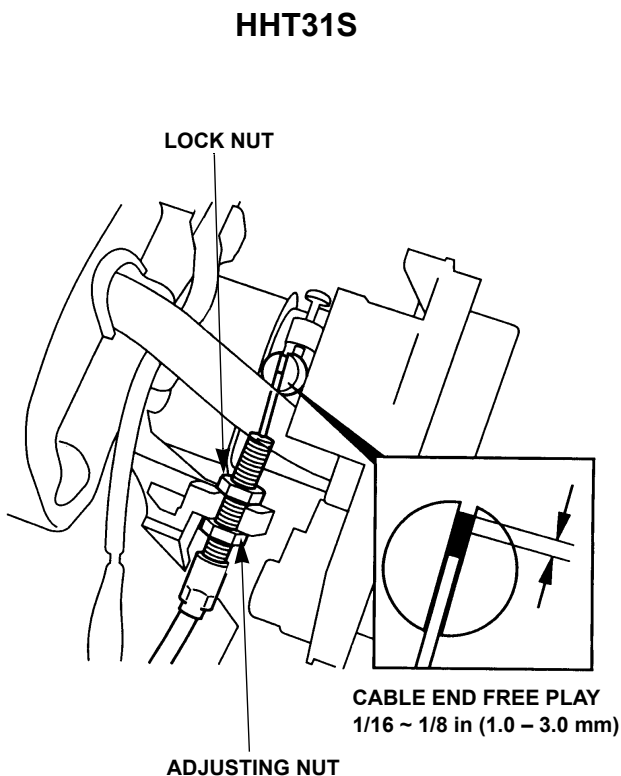

CUTTING ATTACHMENTS

There are several cutting attachments for your trimmer. Use the following section to inspect, remove, service and install a standard (factory-installed) cutting attachment.

Always move the engine switch to the STOP (O) position, and disconnect the spark plug cap before performing any inspection, adjustment or maintenance on the trimmer.

Cutting-Line Heads

All Honda trimmers come with either a manual or semi-matic cutting head. Read this section to learn how to inspect, install new line, and remove and install a cutting head from the trimmer.

Inspection

Make sure the nylon line is only sticking out of the metal eyelets on the head. If any of the line has come off the spool, follow the *Installing Replacement Nylon Line* instructions in this section to disassemble the spool and replace the line.

Examine the entire head area, including the debris shield, and clear or clean it free from dirt, debris, loose string, wire, or any other foreign materials.

For the manual feed head, make sure the three-sided knob is correctly tightened (page 31). For the semi-matic head, verify the spool is locked in place (page 33). For both head styles, check for any cracks in the plastic and replace any damaged parts.

Installing Replacement Nylon Line

First, determine which cutting-line head style is on your trimmer. A manual-feed trimmer head has a three-sided knob on the bottom of the head, while the semi-matic head has a spring-loaded round button on the bottom of the head.

Do not use any kind of metal, wire or wire rope line on the trimmer. Use only genuine Honda replacement nylon trimmer line or equivalent.

Honda trimmers come standard with low noise line. Using non-Honda line may result in increased noise levels.

For original, factory-installed Honda cutting-line heads, use only nylon monofilament line in the line sizes shown below.

	Line Size	
Model	0.095"	0.105"
HHT25S	OK	NO
HHT31S	OK	OK

SERVICING YOUR HONDA TRIMMER

Manual Cutting-Line Head

1. Clean any mud, dirt, debris, etc. from the area around the trimmer head; otherwise, it will make it more difficult to service.
2. Rotate the left-hand threaded knob in the direction of the arrow and remove the knob.

Remove the spring and spool from the housing then remove any remaining old line from the spool.

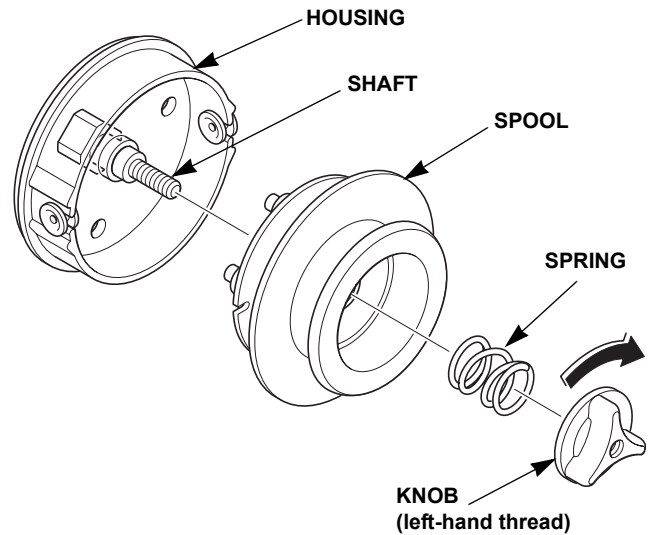

3. Measure approximately 20 feet (6 meters) of line, then thread one end through the hole in the ridge on the spool. Pull the line until the two line lengths are equal.

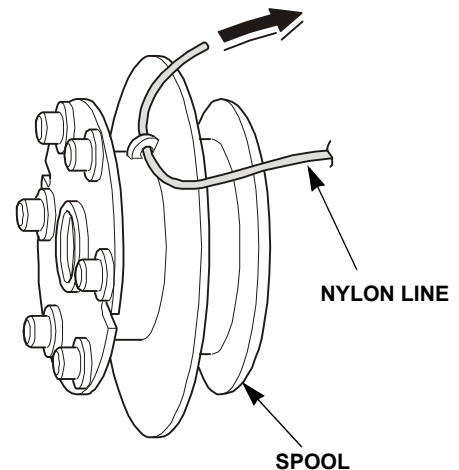

4. Wind both lines tightly and evenly from side-to-side ignoring the ridge. Feed the line while turning the spool in the direction of the arrow. Do not allow the lines to get twisted.

It is important to prevent the two lines from getting twisted over each other. Position a finger between the lines as you turn the spool to prevent the lines from twisting.

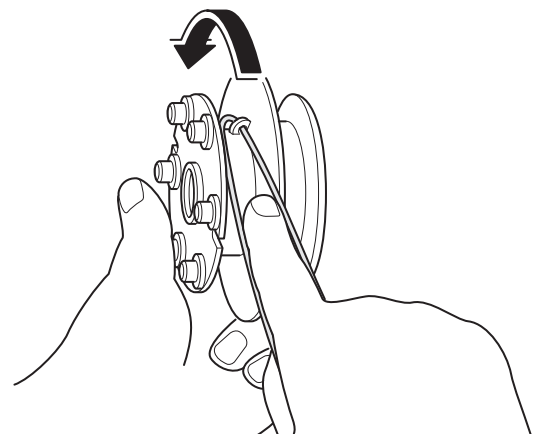

SERVICING YOUR HONDA TRIMMER

- When you have about 6 inches (150 mm) of line remaining, press the lines into the two notches on the bottom of the spool. This will hold the lines on the spool for reassembly.

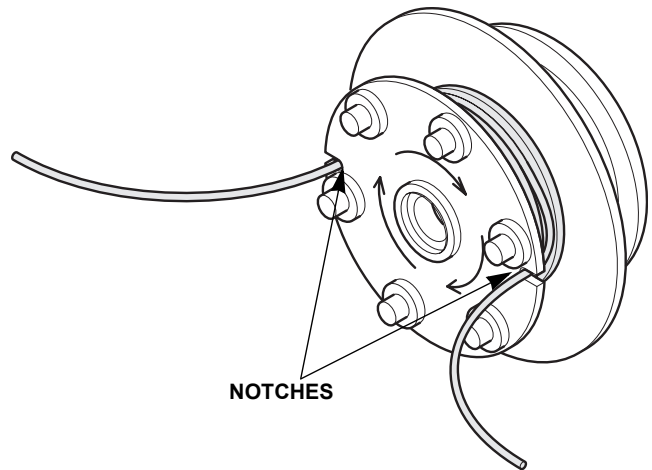

- Feed both line ends through the metal eyelets in the housing.

Be careful not to let the line slip under the spool. When the spool reaches the bottom of the housing, the lines should snap out of the spool notches.

If you are not sure the lines have snapped out of the notches, gently pull the spool away from the housing about an 1/8" to inspect lines. If necessary, gently pull each line until you hear it snap out of the notch. Trim the lines so they are equal length.

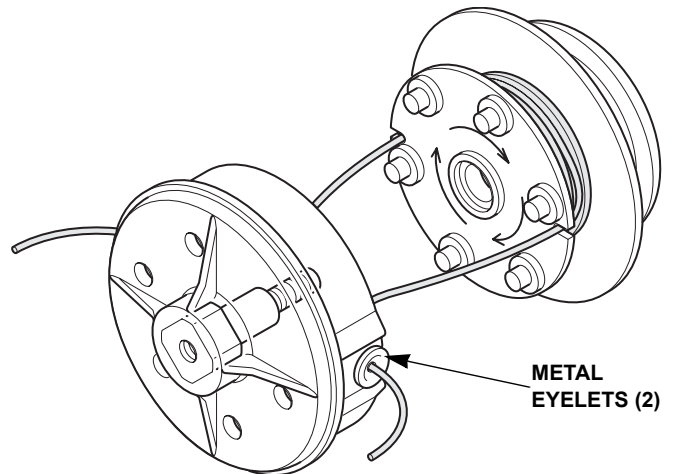

- Install the spring and knob. Rotate the knob in the direction of the arrow and hand tighten securely.

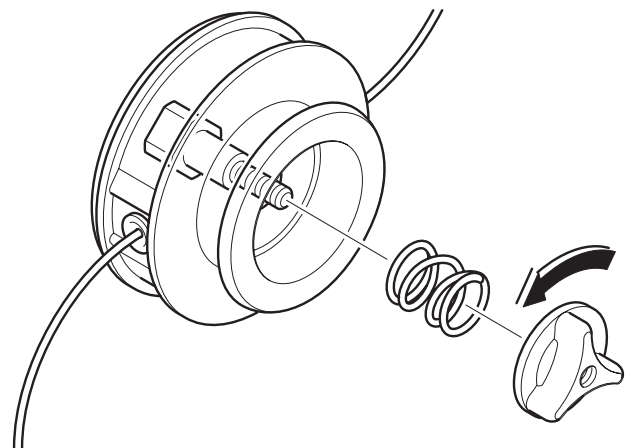

SERVICING YOUR HONDA TRIMMER

Semi-Matic (Bump-Feed) Cutting-Line Head

1. Clean any mud, dirt, debris, etc., from around the trimmer head area; otherwise, it will make it more difficult to service.
2. Locate the half-round locking hole on the spool.

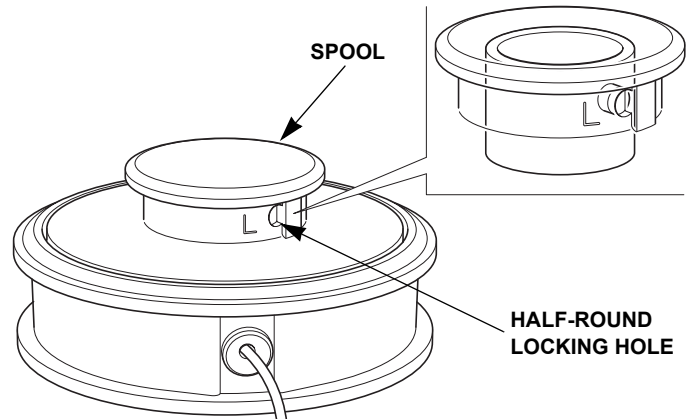

3. It may be necessary to lightly rotate the spool in the direction of the arrow about an 1/8 turn until the spool stops.

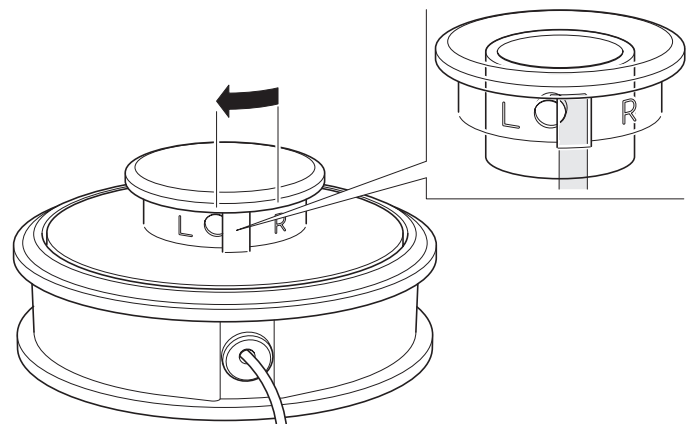

4. Hold the housing securely, then continue to rotate the spool in the direction of the arrow an additional 1/4 inch or the width of the channel to unlock the spool from the housing.

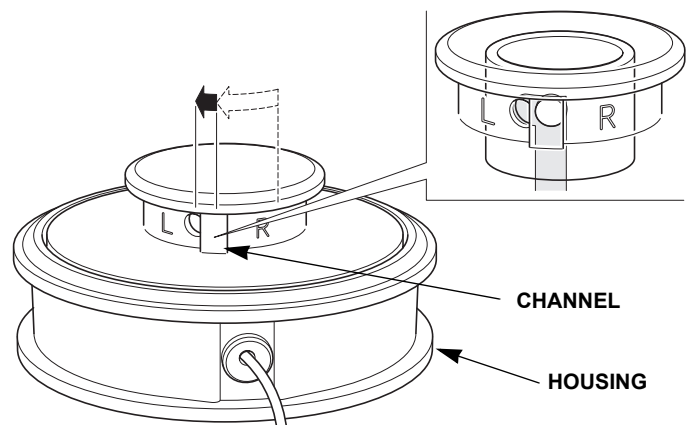

5. Lift the spool out of the housing and remove any remaining line from the spool.

6. Measure approximately 20 feet (6 meters) of new line, then thread one end through the hole in the ridge on the spool.

Pull the line until the two lengths are equal.

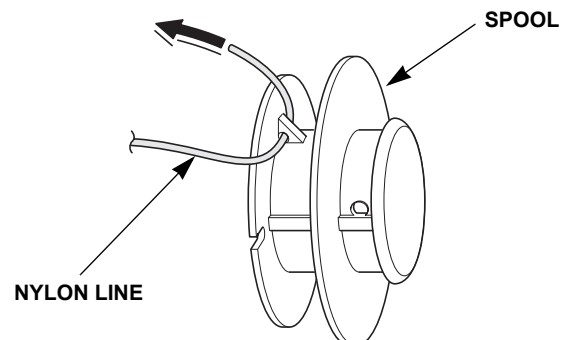

SERVICING YOUR HONDA TRIMMER

7. Wind both lines tightly and evenly from side to side ignoring the ridge. Feed the line while turning the spool in the direction of the arrow. Do not allow the line to get twisted.

It is important to prevent the two lines from getting twisting over each other. Position a finger between the lines as you turn the spool to prevent the lines from twisting.

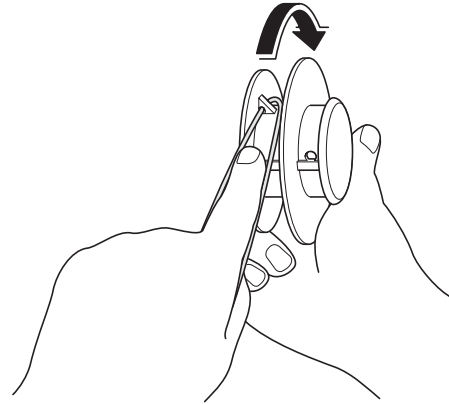

8. When you have about 6 inches (150 mm) of line remaining, press the lines into the two notches on the bottom of the spool. This will hold the lines on the spool for reassembly.

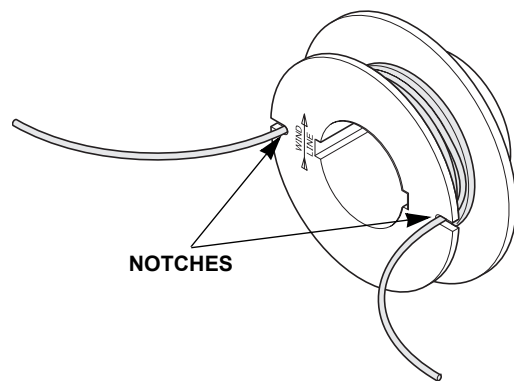

9. It may be necessary to push down and rotate the outer drive until the round lugs align with the metal eyelets.

Feed both line ends through the metal eyelets in the housing.

Align the channels in the spool with the round lugs on the outer drive. With the channels and notches aligned with the metal eyelets, slide the spool into the housing with a continuous snap-in motion. Be careful not to let the line slip under the spool. When the spool reaches the bottom of the housing, the lines should snap out of the spool notches.

If you are not sure if the lines have snapped out of the notches, gently pull the spool away from the housing about an 1/8 inch to inspect the lines. If necessary, gently pull each line until you hear it snap out of the notch.

10. Hold the housing and rotate the spool in the direction of the arrow to lock the round lug into the half-round locking hole. Trim the lines so they are equal length.

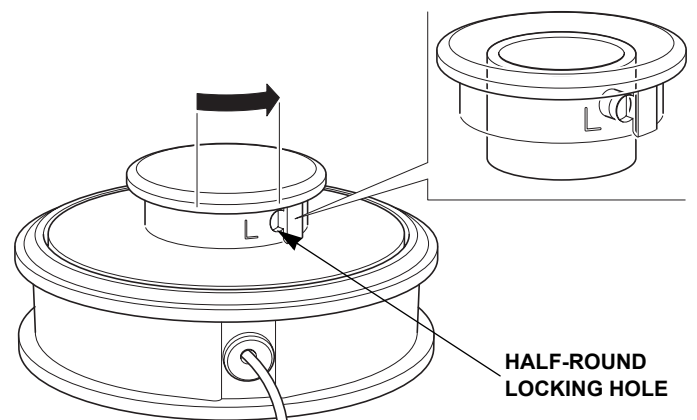
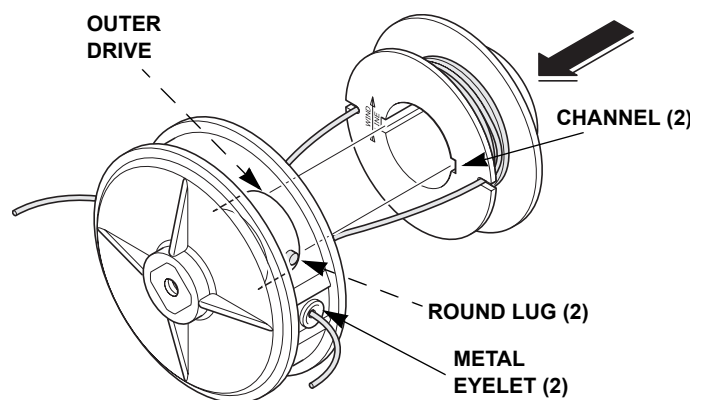

SERVICING YOUR HONDA TRIMMER

Removal & Installation

This section shows you how to remove and install either style trimmer head from your trimmer.

1. Insert the tip of a commercially available 4 mm hex wrench or equivalent fully into the gear case hole.
2. Turn the trimmer cutting-line head until you feel the tool drop into the hole in cover plate/spacer A. Verify the trimmer head does not turn.
3. All output shafts use left-hand threads. Make sure the tool remains in the hole, then grasp the trimmer head and turn in the direction of the arrow to remove.
4. Remove spacer B and cover plate/spacer A from the output shaft. Note the order and orientation of each part as you remove them.
5. Installation is the reverse of removal. Always clean debris, dirt, loose line, etc. from the trimmer head and output shaft area before installation. Tighten the trimmer head securely.

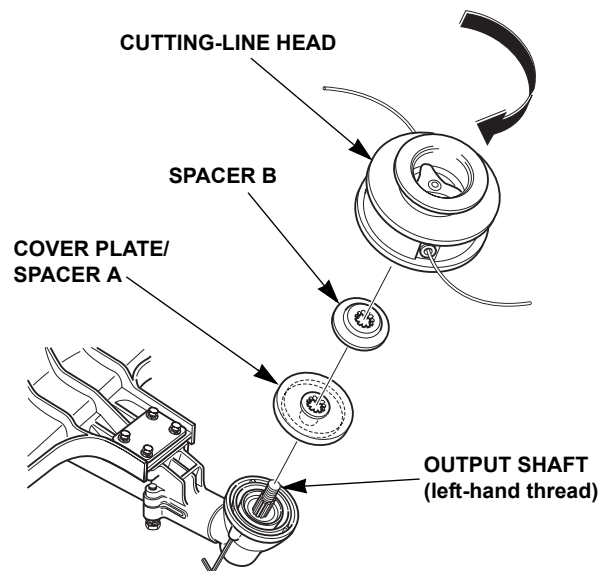
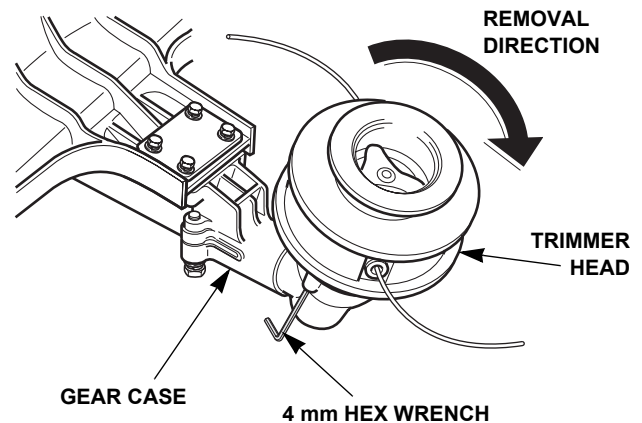

Blade

Blade Inspection

Always wear gloves when working around the blade. Before each use, check the blade for wear and damage, and check the tightness of the blade lock nut. Examine the entire head area, including the debris shield, and clear or clean it free from dirt, debris, loose string, wire, or any other foreign materials.

⚠ WARNING

A worn, damaged or cracked blade can break, and pieces of the damaged blade can become dangerous projectiles.

A dull blade is more likely to snag and thrust (kickback).

Inspect the blade regularly, and do not operate the trimmer with a dull, worn, or damaged blade.

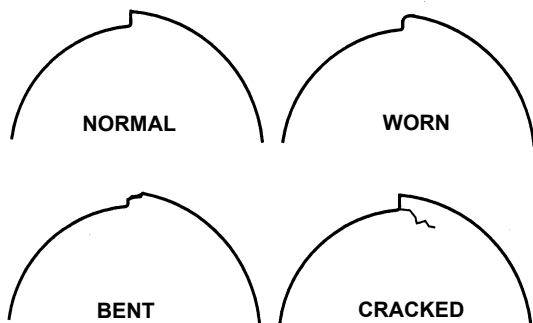

A dull blade can be sharpened, but a blade that is worn out, bent, cracked, chipped, or otherwise damaged must be replaced.

When a blade needs sharpening or replacement, take the trimmer to a Honda trimmer servicing dealer. Or, if you have a torque wrench, you can remove and install a blade yourself.

Blade Removal & Installation (HHT31SUNBA only)

For models other than the HHT31SUNBA, a special optional **Barrier Kit** must be installed before a blade can be used. Refer to the instructions provided with each kit on how to install a blade on loop handle models.

Always wear gloves and install the blade cover on the blade when working around the blade.

A torque wrench is required to install the blade. If you do not have a torque wrench, have a Honda trimmer servicing dealer tighten the blade lock nut for you before using the trimmer.

If the blade lock nut is tightened too much, the output shaft can break. If the blade lock nut is not tightened enough, the blade could come off. In either case, it would be possible for the blade to fly off while you are operating the trimmer.

The blade lock nut is specially designed for this application. When replacing the lock nut, use only a genuine HHT31SUNBA Honda replacement lock nut.

BLADE SHARPENING: To avoid weakening the blade, or causing imbalance or poor cutting, the blade should be sharpened by trained staff at a Honda trimmer servicing dealer.

BLADE REPLACEMENT: Your Honda trimmer servicing dealer has cutting attachments that have been designed and approved for your trimmer and are covered by a warranty. Non-Honda attachments are usually designed for universal applications. Although, aftermarket attachments may fit on your trimmer, they may not meet factory specifications and could make your trimmer unsafe.

SERVICING YOUR HONDA TRIMMER

1. Install the protective plastic cover, that came with the blade, back on the blade.
2. Insert a commercially available 4 mm hex tool or equivalent fully into the gear case hole.
3. Turn the blade until you feel the tool drop into the hole in cover plate/spacer A. Verify the blade does not turn. The output shaft and blade lock nut have a left-hand thread. Make sure the tool remains in the hole, then loosen the blade nut as shown. Pay attention to the order and orientation of the parts as they are removed.
4. Installation is the reverse of removal. Make sure you install the blade with the cutting edges in the direction of rotation. Be sure to align the hole in the blade with the shoulder on cover plate/spacer A. Tighten the blade nut with a torque wrench.

Blade nut torque: 14 ft-lb (20 N · m, 2.0 kg-m)

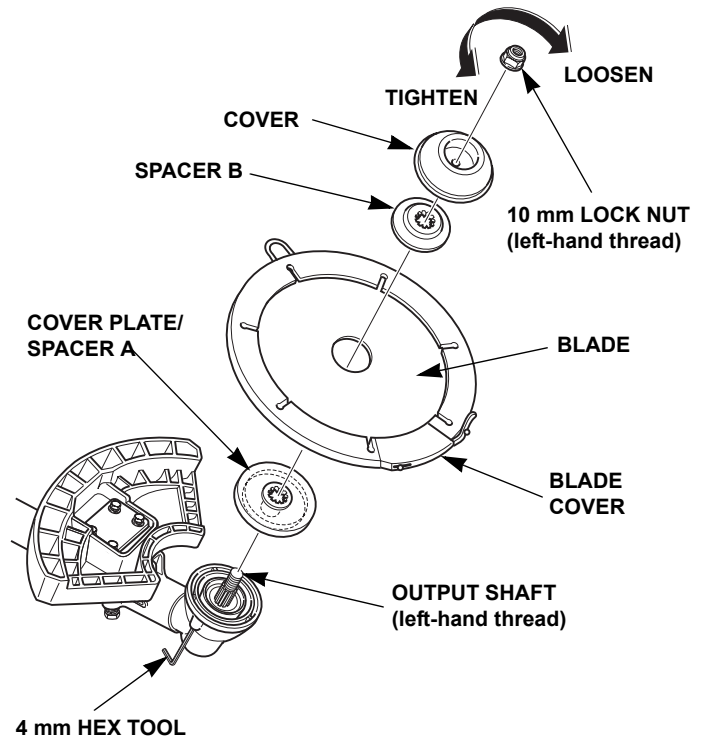

Changing the Debris Shield

Refer to the applicable illustration for removing and installing the debris shields. Tighten the bolts/washers securely with a torque wrench.

Spacer bolt/washers torque: 2.5 ft-lb (3.4 N · m, 0.34 kg-m).

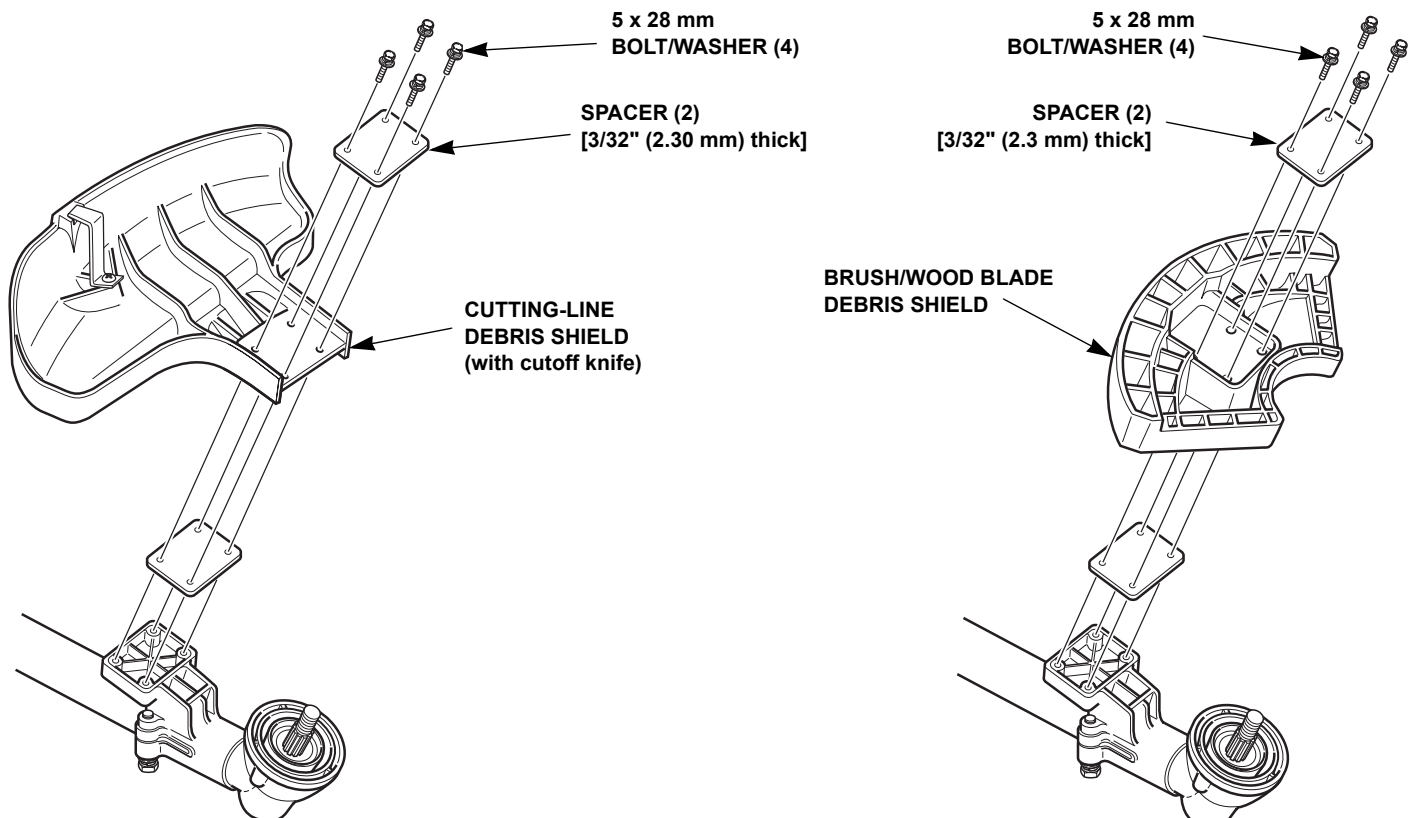

SERVICING YOUR HONDA TRIMMER

Spark Plug Service

Recommended spark plugs:

HHT25S	CMR5HSB (NGK)
HHT31S	CR5HSB (NGK)
	U16FSR-UB (DENSO)

NOTICE

Incorrect spark plugs can cause engine damage.

1. HHT25S model: Remove the 5 x 12 mm hex bolt and top cover.
2. Disconnect the spark plug cap, and remove any dirt from around the spark plug area.
3. Remove the spark plug with a 5/8-inch spark plug wrench.
4. Inspect the spark plug. Replace it if the electrodes are worn, or if the insulator is cracked or chipped.
5. Measure the spark plug electrode gap with a suitable gauge. The gap should be 0.024 ~ 0.028 in (0.60 ~ 0.70 mm). Correct the gap, if necessary, by carefully bending the side electrode.
6. Install the spark plug carefully, by hand, to avoid cross-threading.
7. After the spark plug seats, tighten with a 5/8-inch spark plug wrench to compress the washer.

If reinstalling the used spark plug, tighten 1/8 ~ 1/4 turn after the spark plug seats.

If installing a new spark plug, tighten 1/2 turn after the spark plug seats.

NOTICE

A loose spark plug can overheat and damage the engine. Overtightening the spark plug can damage the threads in the cylinder head.

8. Attach the spark plug cap.

HHT25S model: Install the top cover and 5 x 12 mm hex bolt and tighten securely.

TORQUE: 51.6 in-lb (1.09 N•m)

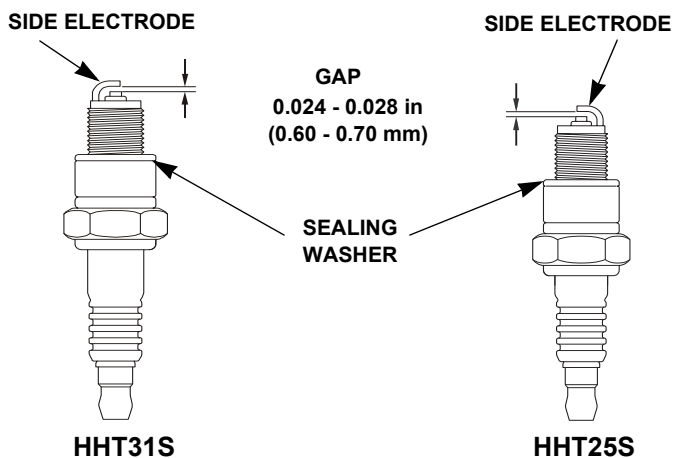
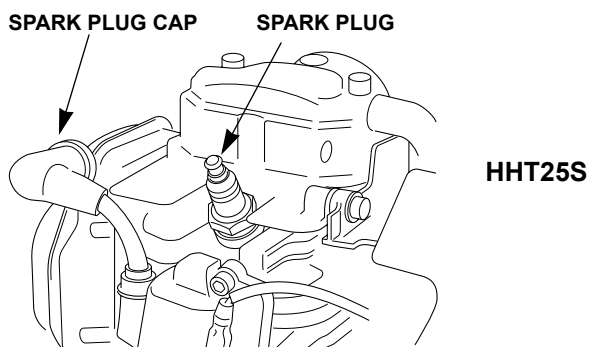
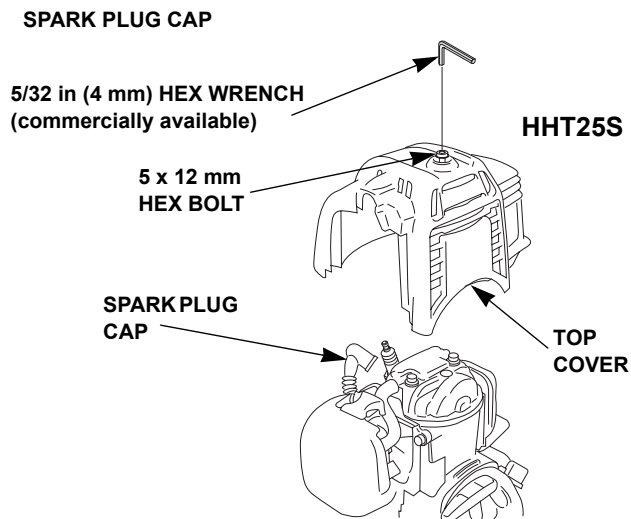
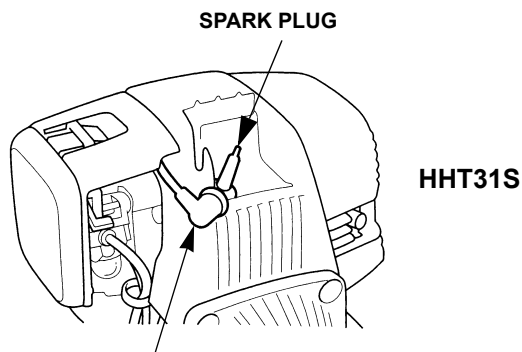

SERVICING YOUR HONDA TRIMMER

Spark Arrester Service

HHT31S

The spark arrester must be serviced every 100 hours to keep it functioning as designed.

If the engine has been running, the muffler will be very hot. Allow the muffler to cool before servicing the spark arrester.

1. Remove the four 5 x 18 mm bolts from the recoil starter, and remove the recoil starter.
 2. Disconnect the spark plug cap from the spark plug. Pull the spark plug wire and the ignition switch wire out of the retainers in the top cover.
 3. Remove the two 5 x 22 mm bolts from the top cover, and remove the top cover.
 4. Remove the three 5 mm screws from the muffler cover, and remove the muffler cover.
 5. Remove the 4 mm screw from the spark arrester, and remove the spark arrester.
 6. Use a brush to remove carbon deposits from the spark arrester screen. Be careful to avoid damaging the screen.
- The spark arrester must be free of breaks and holes. Replace the spark arrester if it is damaged.
7. Install the spark arrester, muffler cover, top cover, and recoil starter in the reverse order of disassembly.

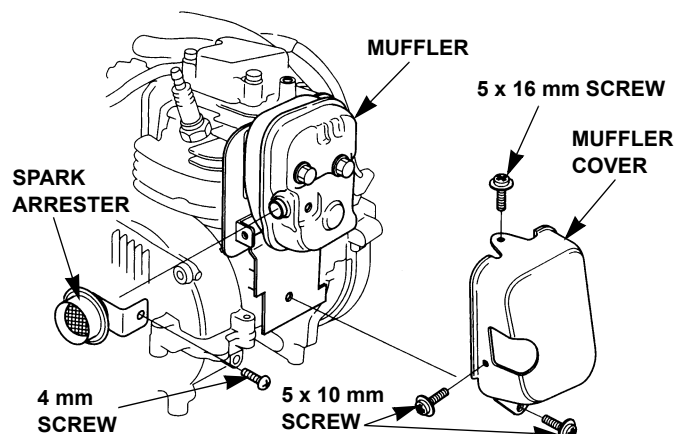
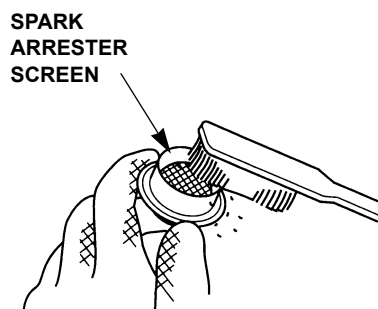
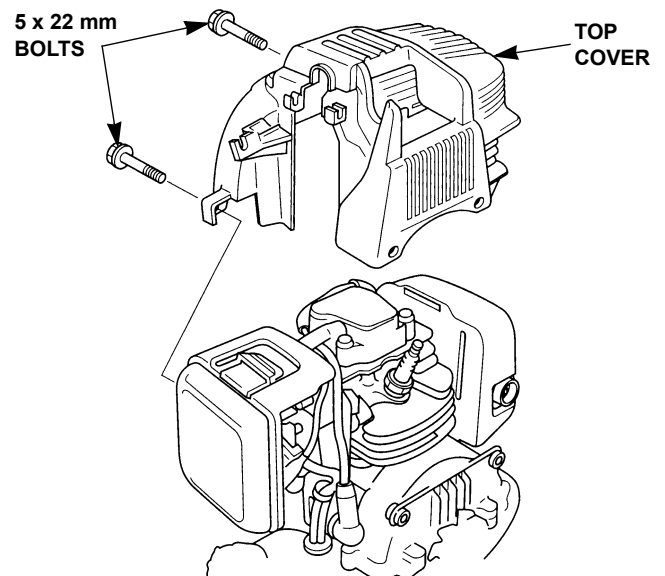
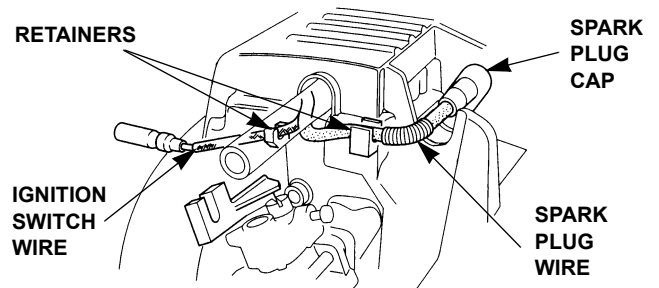
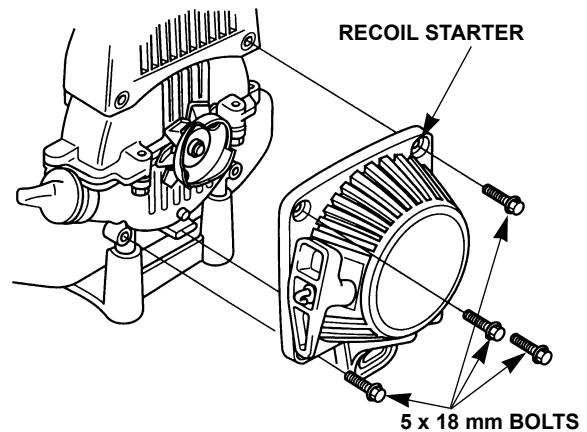

SERVICING YOUR HONDA TRIMMER

HHT25S

The spark arrester must be serviced every 100 hours to keep it functioning as designed.

If the engine has been running, the muffler will be very hot. Allow the muffler to cool before servicing the spark arrester.

1. Remove the 5 x 12 mm hex bolt and top cover
2. Remove the two 4 x 6 mm self-tapping screws from the spark arrester, and remove the spark arrester from the muffler.
3. Use a brush to remove carbon deposits from the spark arrester screen. Be careful to avoid damaging the screen.

The spark arrester must be free of breaks and holes. Replace the spark arrester if it is damaged.

4. Install the spark arrester, top cover, and 5 x 12 mm hex bolt in the reverse order of disassembly.

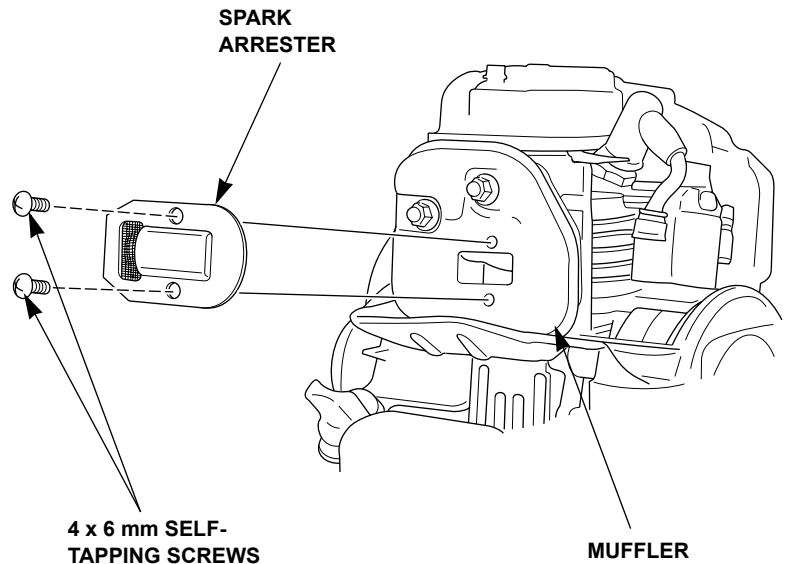
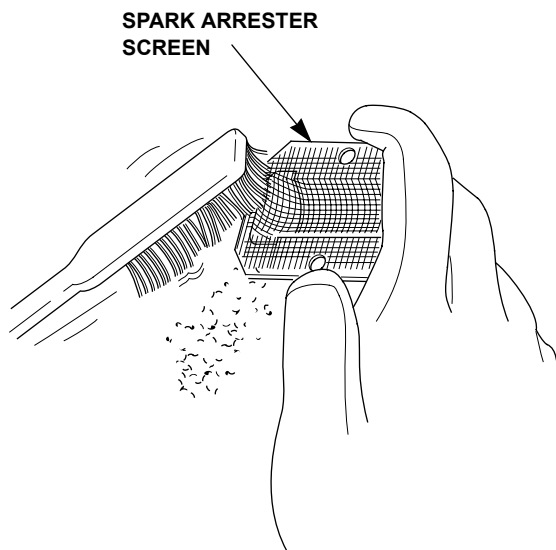
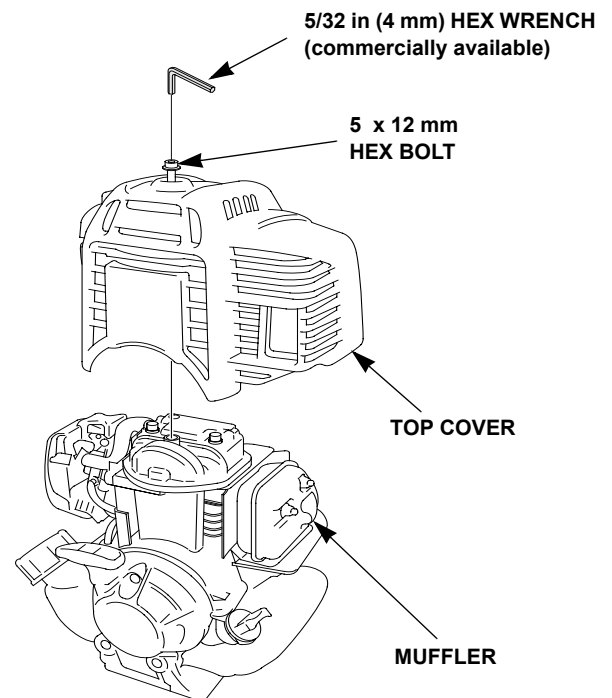

SERVICING YOUR HONDA TRIMMER

FUEL SYSTEM

Refueling

Fuel tank capacities:

HHT25S: 0.53 qt/16.9 fl oz (0.50 ℓ)

HHT31S: 0.69 qt/22.0 fl oz (0.65 ℓ)

Check the fuel level by looking through the translucent fuel tank. If the fuel level is low, refuel in a well-ventilated area with the engine stopped. If the engine has been running, allow it to cool first.

To refuel, rest the trimmer on the ground with the fuel tank cap facing up, as shown. Remove the fuel tank cap, and fill the tank with gasoline to the bottom of the filler neck. Refuel carefully to avoid spilling fuel. Do not overfill. There should be no fuel in the filler neck. After refueling, tighten the fuel tank cap securely.

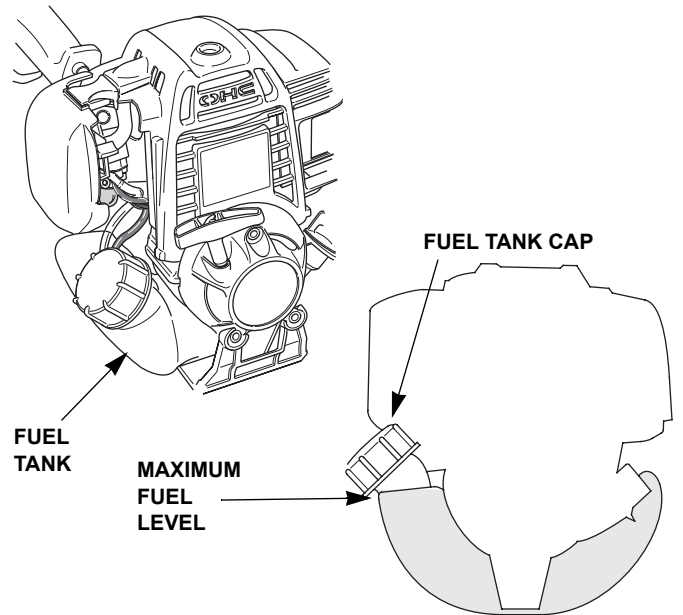

Fuel Recommendations

Use unleaded gasoline with a pump octane rating of 86 or higher.

These engines are certified to operate on unleaded gasoline. Unleaded gasoline produces fewer engine and spark plug deposits and extends exhaust system life.

Never use stale or contaminated gasoline or an oil/gasoline mixture. Avoid getting dirt or water in the fuel tank.

Occasionally you may hear a light “spark knock” or “pinging” (metallic rapping noise) while operating under heavy loads. This is no cause for concern.

If spark knock or pinging occurs at a steady engine speed, under normal load, change brands of gasoline. If spark knock or pinging persists, see an authorized Honda servicing dealer.

NOTICE

Running the engine with persistent spark knock or pinging can cause engine damage.

Running the engine with persistent spark knock or pinging is misuse, and the *Distributor's Limited Warranty* does not cover parts damaged by misuse.

⚠ WARNING

Gasoline is highly flammable and explosive.

You can be burned or seriously injured when handling fuel.

- Stop the engine and keep heat, sparks, and flame away.
- Handle fuel only outdoors.
- Wipe up spills immediately.

Never refuel the engine inside a building where gasoline fumes may reach flames or sparks. Keep gasoline away from appliance pilot lights, barbecues, electric appliances, power tools, etc.

Spilled fuel is not only a fire hazard, it causes environmental damage. Wipe up spills immediately.

Move at least 10 feet (3 meters) away from the fueling source and site before starting the engine.

NOTICE

Fuel can damage paint and plastic. Be careful not to spill fuel when filling your fuel tank. Damage caused by spilled fuel is not covered under warranty.

SERVICING YOUR HONDA TRIMMER

Fuel Filter and Fuel Tank Cleaning

1. Remove the fuel tank cap, and empty the fuel tank into an approved gasoline container. Use a funnel to avoid spilling gasoline.
2. Pull the fuel filter out through the fuel filler neck by hooking the black fuel supply tube with a piece of wire, such as a partly straightened paper clip.
3. Inspect the fuel filter. If the fuel filter is dirty, remove it and wash it with nonflammable solvent. Be careful to avoid damaging the filter.

Replace the filter if it is damaged or excessively dirty.

4. Rinse sediment from the fuel tank with nonflammable solvent.
5. Insert the fuel filter in the fuel tank, and install the fuel tank cap.

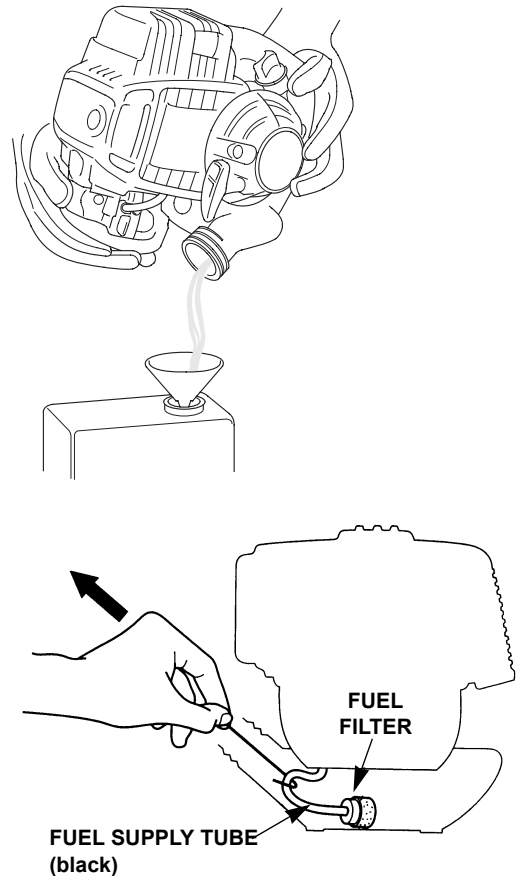

Cooling Fin Inspection

Inspect the engine cooling fins, and clean out any dirt and debris.

On both the HHT25S and HHT31S, it is necessary to remove the top cover. Removal procedures are located on page 37 for HHT25S and page 38 for the HHT31S.

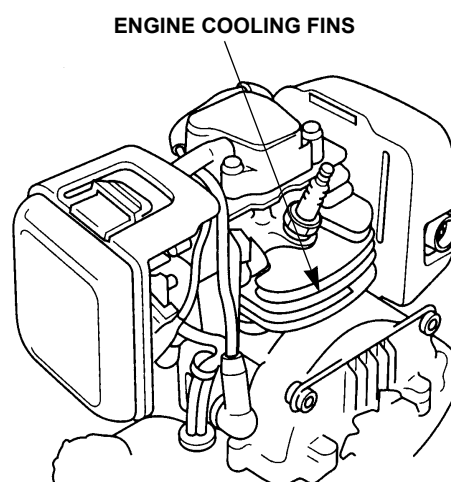
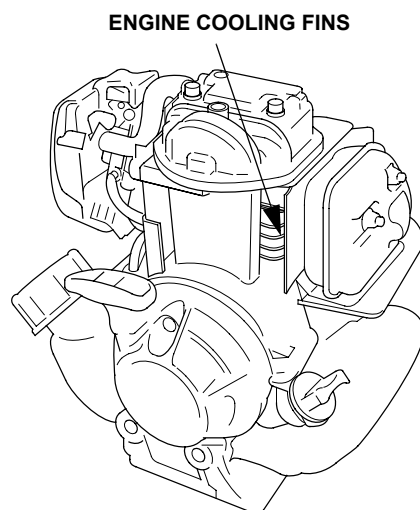

ASSEMBLY

After assembly and before operation review the Safe Operating Precautions on page 17.

IMPORTANCE OF PROPER ASSEMBLY

Proper assembly is essential to operator safety and the reliability of the machine. Any error or oversight made by the person assembling and servicing a machine can result in faulty operation, damage to the machine, or injury to the operator.

Some of the most important safety precautions are given below. However, we cannot warn you of every conceivable hazard that can arise in performing this assembly. Only you can decide whether or not you should perform a given task.

WARNING

Improper assembly can cause an unsafe condition that can lead to serious injury or death.

Follow the procedures and precautions in the assembly instructions carefully.

WARNING

Failure to properly follow instructions and precautions can cause you to be seriously hurt or killed.

Follow the procedures and precautions in this manual carefully.

IMPORTANT SAFETY PRECAUTIONS

- Make sure you have a clear understanding of all basic shop safety practices and that you are wearing appropriate clothing and safety equipment. When performing this assembly, be especially careful of the following:
 - Read the instructions before you begin and be sure you have the tools and skills required to perform the tasks safely.
- Make sure the engine is off before you begin any maintenance or repairs. This will help eliminate several potential hazards:
 - Carbon monoxide poisoning from engine exhaust. Be sure there is adequate ventilation whenever you run the engine.
 - Burns from hot parts. Let the engine and exhaust system cool before touching.
 - Injury from moving parts. Do not run the engine unless the instruction tells you to do so. Even then, keep your hands, fingers, and clothing away from moving parts. Do not run the engine when any protective guard or shield is removed.
- To reduce the possibility of a fire or explosion, be careful when working around gasoline or batteries. Use only a nonflammable solvent, not gasoline, to clean parts. Keep all cigarettes, sparks, and flames away from all fuel-related parts.

UNPACKING

Carefully remove the trimmer and loose parts from the carton and compare the loose parts with the inventory list below.

Tools Required (UNBA types only):

A 4 mm hex wrench, 8 and 17 mm sockets, 0 to 25 ft-lb torque wrench.

LOOSE PARTS

Check all loose parts against the following list. Contact your authorized Honda servicing dealer if any of the loose parts shown are not included with your trimmer.

Ref. No	Description	All	LTA types only	UNBA types only	Qty.
1	Owner's Manual	•			1
2	Goggles	•			1
3	Oil bottle	•			1
4	Single-strap shoulder harness		•		1
5	Full shoulder harness			•	1
6	Debris shield, for 30 ~ 80 tooth saw blades only			•	1
7	Cover			•	1
8	Left-hand thread lock nut, 10 mm			•	1
9	Saw blade, 50 tooth/10 in			•	1
10	Blade cover			•	1

ASSEMBLY

TRIMMER ASSEMBLY (UNBA types only)

U-Shaped Handlebar Installation

1. Remove the four 5 x 28 mm bolt/washers and handlebar holder A.
2. Set the U-shaped handle into handlebar holder B with the throttle trigger facing to the right.

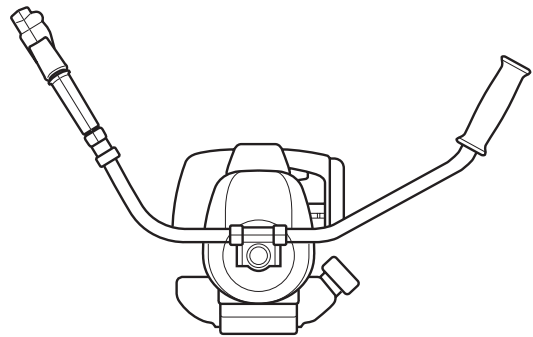
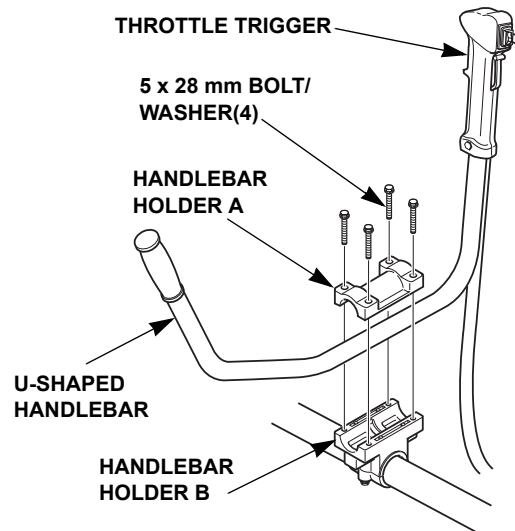

3. Adjust the handlebar position as shown.

4. Tighten the four 5 x 28 mm bolt/washers.
TORQUE: 3.6 ft lb (5 N · m, 0.5 kg-m)

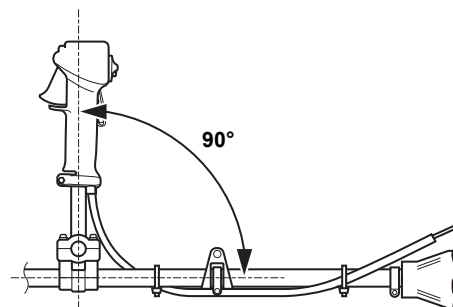

5. Make sure the tie straps are positioned as shown.

6. Operate the throttle trigger and make sure the throttle operates smoothly.

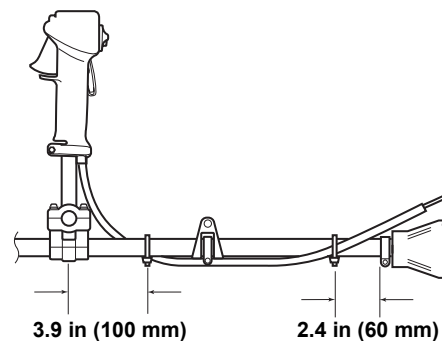

Saw Blade

The UNBA types are shipped with a manual nylon cutting-line head installed on the trimmer. If the saw blade is needed, move the ignition switch to the STOP (O) position and disconnect the spark plug cap from the spark plug. Wear protective gloves when working around the cutting-line head and saw blade.

Cutting-Line Head Removal

1. Align the gear case hole with the groove in cover plate/spacer A. Insert a 4 mm hex wrench or equivalent into the gear case hole to prevent the left-hand threaded output shaft from turning.
2. Hold the wrench and rotate the cutting-line head in the direction of the arrow to remove the cutting-line head.

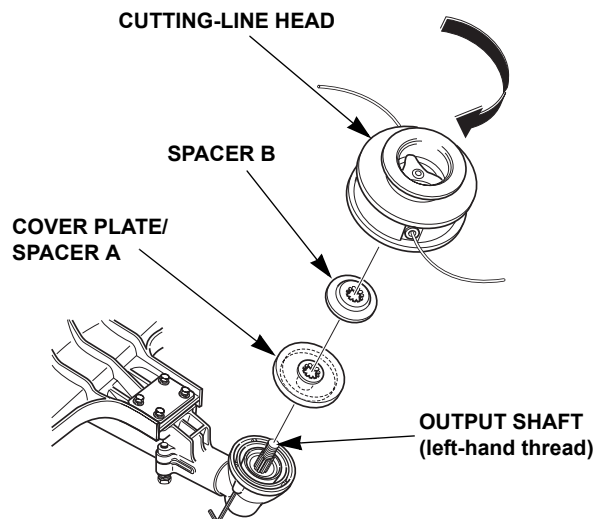

Debris Shield Removal/Installation

Remove the cutting-line debris shield and install the brush/wood blade debris shield.

Tighten the bolt/washers:

TORQUE: 2.5 ft-lb (3.4 N · m, 0.34 kg-m)

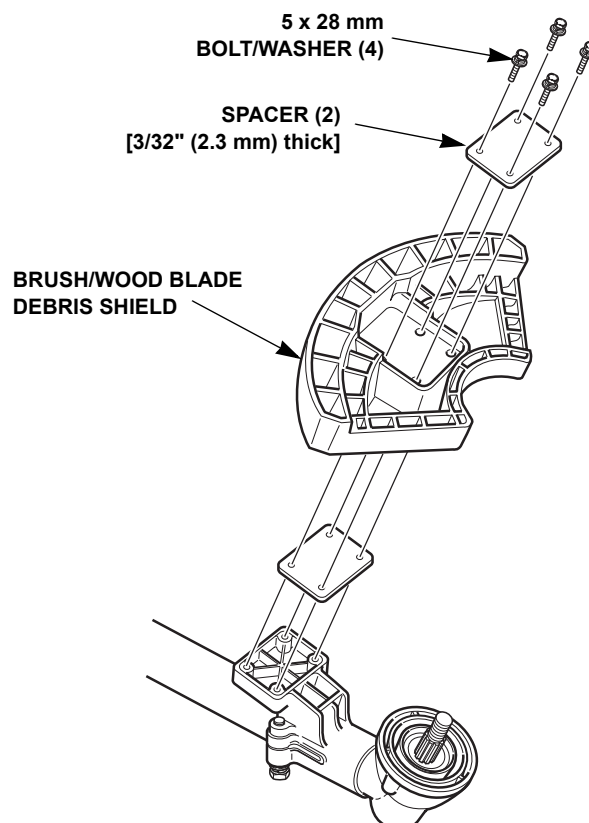
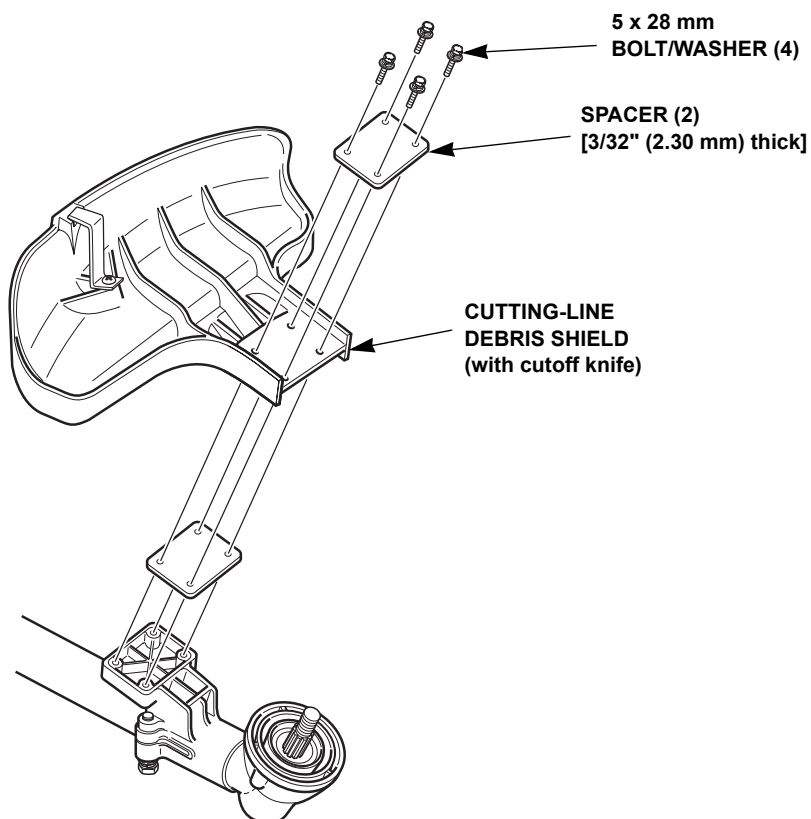

ASSEMBLY

Saw Blade Installation

1. Insert a 4 mm hex wrench or equivalent into the gear case hole to prevent the output shaft from turning.
2. Install cover plate/spacer A onto the output shaft as shown.
3. With the blade cover installed on the blade, install the blade, by aligning the center of the blade with the shoulder on cover plate/spacer A.
4. Install spacer B, the cover, and the 10 mm lock nut as shown.

Be sure to install the blade with the cutting edges of the saw teeth in the direction of rotation; the side with the white markings must face the debris shield.

The output shaft has left-hand threads. Tighten the 10 mm lock nut counterclockwise.

TORQUE: 14 ft-lb (20 N•m, 2.0 kg-m)

5. Remove the 4 mm hex wrench or equivalent from the gear case.

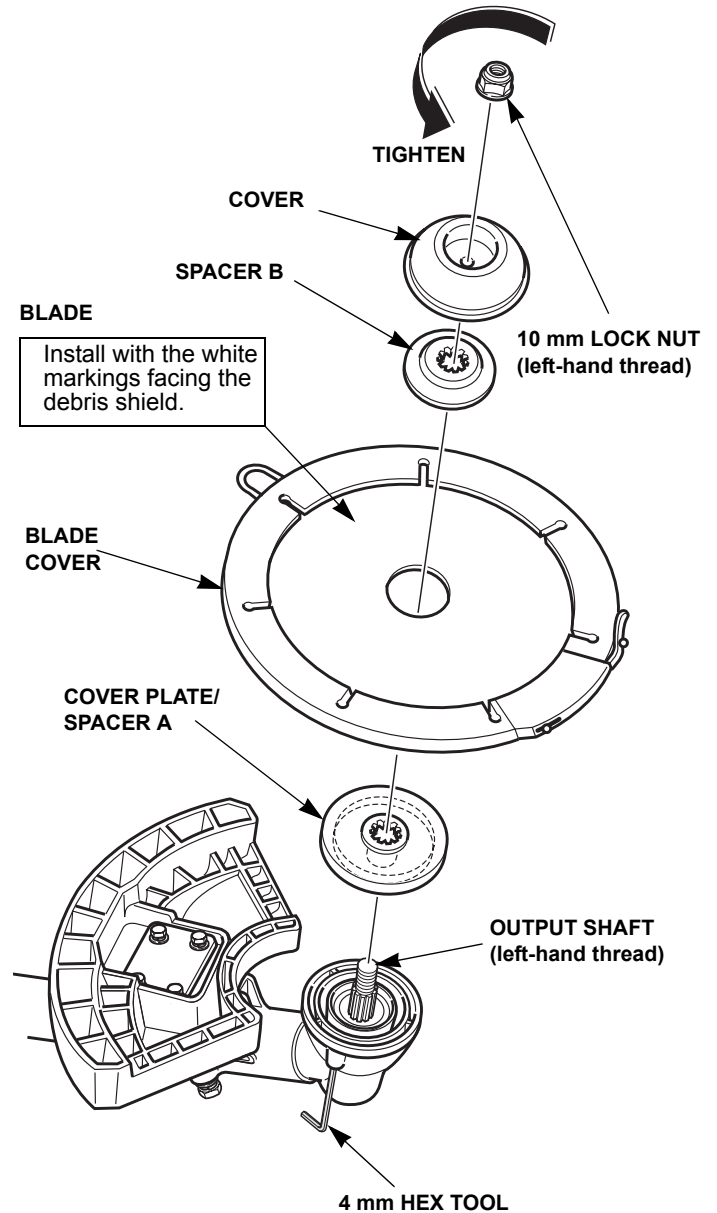

BLADE COVER REMOVAL

1. Turn the blade cover slowly until the cover latch is clear of the debris shield.

Unfasten the latch by lifting the tab off the post.

2. Pull the post end away from the blade and set it on top of the blade as shown.

3. Turn the blade cover slowly until the post end is clear of the debris shield, then remove the blade cover from the blade.

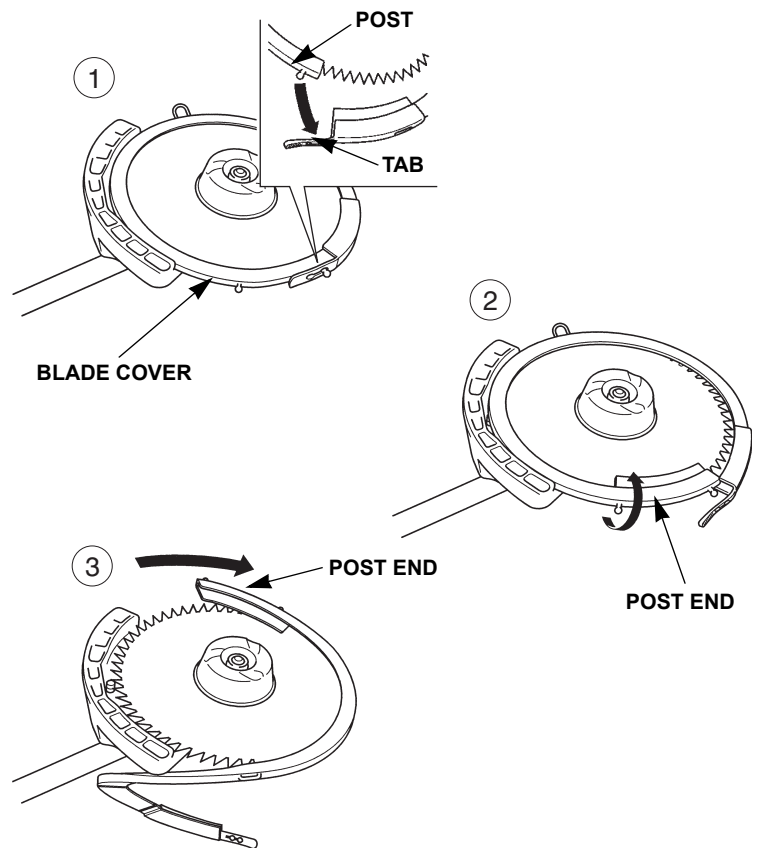

BLADE COVER INSTALLATION

1. Install the blade cover over the blade so half of the blade is covered.

To prevent the post end from interfering with the debris shield, pull the post end away from the blade and set it on top of the blade as shown.

Turn the blade cover slowly until the post end clears the debris shield.

2. Reposition the post end over the blade.

3. With the blade cover fully seated on the blade, latch the tab over the post.

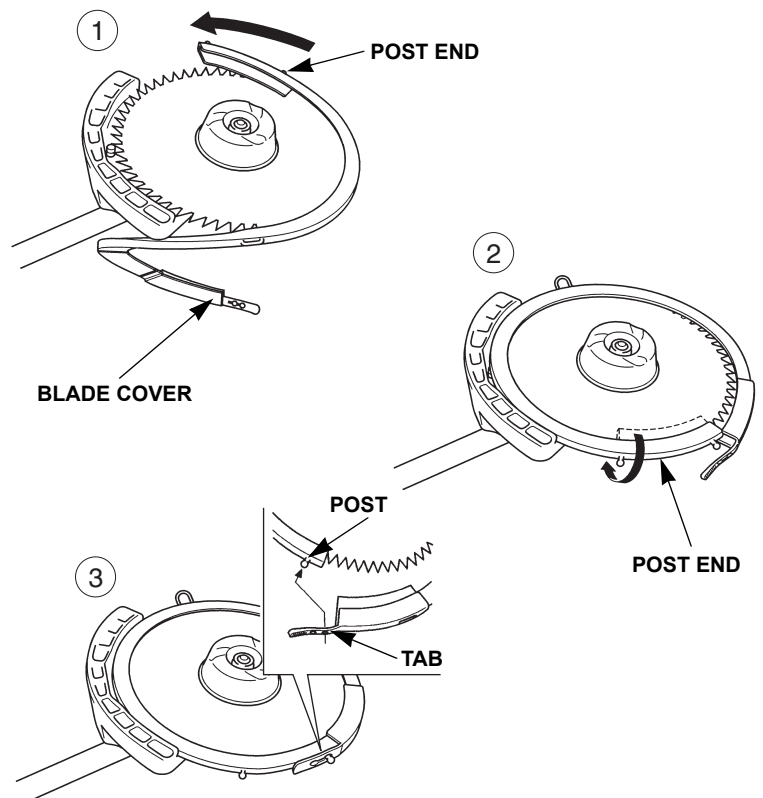

ASSEMBLY

ENGINE OIL

1. Working on a level surface, remove the oil filler cap/dipstick.

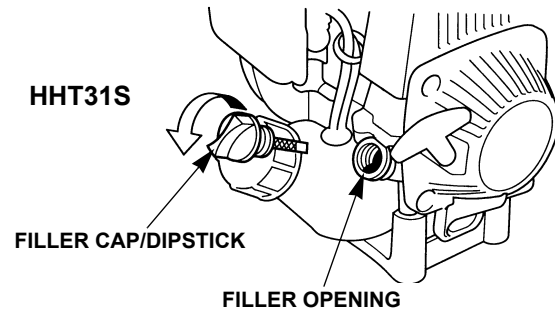

2. Slowly add the recommended oil (included in the box) to the bottom edge of the oil fill hole. Do not overfill, as the engine oil tank capacity is small.

Engine oil capacity:

HHT25S 2.7 fl oz (80 cc)

HHT31S 3.4 fl oz (100 cc)

NOTICE

Running the engine with too little or too much oil can cause engine damage.

3. Screw in the oil filler cap/dipstick securely.

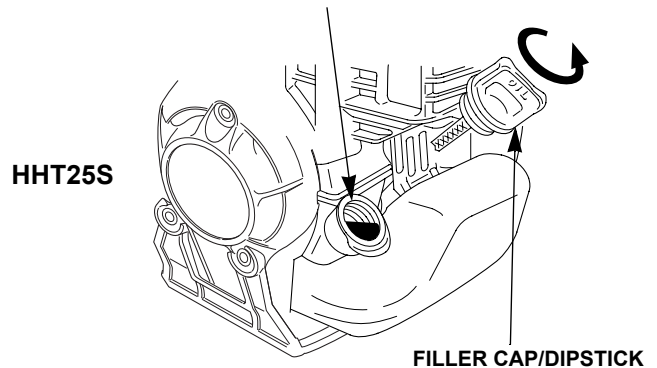

FUEL

Refer to Refueling section of the **SERVICING YOUR HONDA TRIMMER** chapter (page 40).

BEFORE OPERATION

On blade equipped UNBA types, always remove the blade cover before starting the engine. If the cover is not removed, the blade cover may fly off at high speed during test operation. Reinstall the blade cover when the trimmer is not being used.

Before using the trimmer, all trimmer operator's must read the following chapters.

- **TRIMMER SAFETY** (page 4)
- **CONTROLS & EQUIPMENT** (page 11)
- **BEFORE OPERATION** (page 14)
- **OPERATION** (page 17)

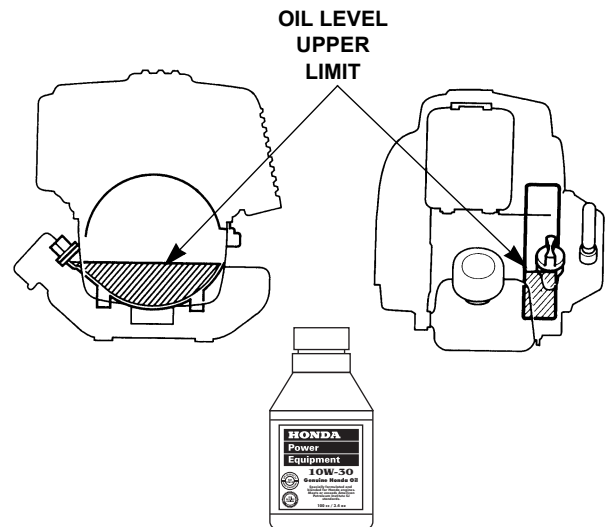

STORAGE

STORAGE PREPARATION

Proper storage preparation is essential to keep your trimmer trouble free and looking good. The following steps will help to keep rust and corrosion from impairing your trimmer's function and appearance, and will make the engine easier to start when you use the trimmer again.

Cleaning

Wash the trimmer, including the area around the trimmer head.

Wash the engine by hand, and be careful to prevent water from entering the air cleaner.

NOTICE

Using a garden hose or pressure washing equipment can force water into the air cleaner. Water in the air cleaner will soak the filter and can enter the carburetor or engine, causing damage.

Water on a hot engine can cause damage. If the engine has been running, allow it to cool for at least 1/2 hour before washing.

If using a garden hose or pressure washing equipment to clean the trimmer, be careful to avoid getting water into controls and cable, or anywhere near the engine air cleaner or muffler opening.

Before washing the trimmer head area, disconnect the spark plug cap from the spark plug.

After washing the trimmer, wipe dry all accessible surfaces.

Start the engine outdoors, and let it run until it reaches normal operating temperature to evaporate any water remaining on the engine.

Stop the engine and allow it to cool.

After the trimmer is clean and dry, coat areas that may rust with a light film of oil. Lubricate the control cable cores with a silicone spray lubricant.

Fuel

Gasoline will oxidize and deteriorate in storage. Old gasoline will cause hard starting, and it leaves gum deposits that clog the fuel system. If the gasoline in your trimmer deteriorates during storage, you may need to have the carburetor and other fuel system components, serviced or replaced.

The length of time that gasoline can be left in your fuel tank and carburetor without causing functional problems will vary with such factors as gasoline blend, your storage temperatures, and whether the fuel tank is partially or completely filled. The air in a partially filled fuel tank promotes fuel deterioration. Very warm storage temperatures accelerate fuel deterioration. Fuel deterioration problems may occur within a few months, or even less if the gasoline was not fresh when you filled the fuel tank.

The *Distributors Limited Warranty* does not cover fuel system damage or engine performance problems resulting from neglected storage preparation.

You can extend fuel storage life by adding a gasoline stabilizer that is formulated for that purpose, or you can avoid fuel deterioration problems by draining the fuel tank and carburetor.

STORAGE

Adding Fuel Stabilizer to Extend Fuel Storage Life

When adding a fuel stabilizer, fill the fuel tank with fresh gasoline. If only partially filled, air in the tank will promote fuel deterioration during storage. If you keep a container of gasoline for refueling, be sure that it contains only fresh gasoline.

Add fuel stabilizer following the manufacturer's instructions.

After adding a fuel stabilizer, run the engine outdoors for 10 minutes to be sure that treated gasoline has replaced the untreated gasoline in the carburetor.

Draining the Fuel Tank and Carburetor

Disconnect the spark plug cap. Make sure the ignition switch is in the STOP (O) position.

Drain the fuel from the fuel tank to a suitable container. Press the primer bulb a few times to draw any remaining fuel out of the carburetor, then drain this fuel from the tank.

Engine Oil

Change the engine oil (see page 26).

Carburetor & Air Cleaner

Clean the air filter (see page 27) and move the choke lever to the CLOSED position.

Blade

If a blade is installed, put the blade cover on the blade.

Engine Cylinder

Remove the spark plug (see page 37). Pour a 1/4 tablespoon (1 ~ 3 cc) of clean engine oil into the cylinder. Pull the starter rope several times to distribute the oil in the cylinder. Reinstall the spark plug. Pull the starter rope slowly until resistance is felt then return the starter grip gently. This closes the valves so moisture cannot enter.

STORAGE PRECAUTIONS

If your trimmer will be stored with gasoline in the fuel tank and carburetor, it is important to reduce the hazard of gasoline vapor ignition. Select a well-ventilated storage area away from any appliance that operates with a flame, such as a furnace, water heater, or clothes dryer. Also avoid any area with a spark-producing electric motor, or where power tools are operated.

If possible, avoid storage areas with high humidity, because that promotes rust and corrosion.

With the engine and exhaust system cool, cover the trimmer to keep out dust. A hot engine and exhaust system can ignite or melt some materials. Do not use sheet plastic as a dust cover. A non-porous cover will trap moisture, promoting rust and corrosion.

REMOVAL FROM STORAGE

Check your trimmer as described in the BEFORE OPERATION chapter of this manual.

If the fuel was drained during storage preparation, fill the tank with fresh gasoline. If you keep a container of gasoline for refueling, be sure that it contains only fresh gasoline. Gasoline oxidizes and deteriorates over time, causing hard starting.

If the cylinder was coated with oil during storage preparation, the engine will smoke briefly at startup. This is normal.

TRANSPORTING

BEFORE LOADING

If the engine has been running, allow it to cool for at least 15 minutes before loading the trimmer on the transport vehicle. A hot engine and exhaust system can burn you and can ignite some materials.

Always turn the ignition switch to the STOP (O) position. Make sure the fuel cap is securely tightened.

LOADING

The trimmer may be secured by suitable clamps, hangers or straps. Secure the trimmer by at least two points along the frame pipe. Avoid securing the trimmer by the engine, cutting head/gear case or handle area. The trimmer should be secured in a horizontal position, with the engine upright as shown.

Don't hang the trimmer by the gear case or cutting head, or they may be damaged.

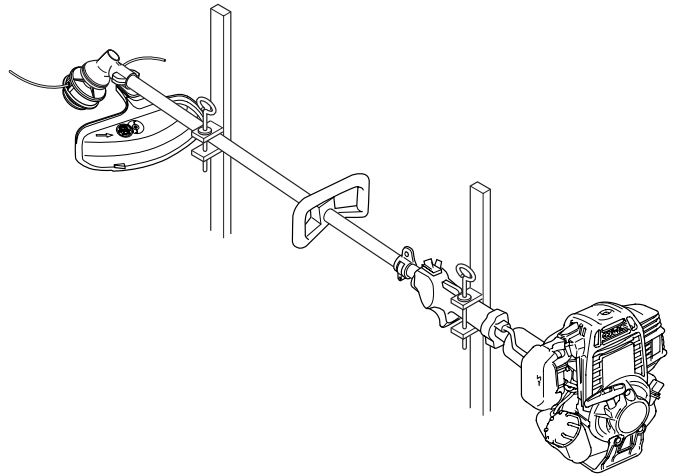

TAKING CARE OF UNEXPECTED PROBLEMS

STARTING PROBLEMS

Engine Will Not Start	Possible Cause	Correction
Check control positions.	Ignition switch STOP (O).	Turn ignition switch ON (I).
	Choke not in CLOSED (cold engine).	Move choke to the CLOSED position.
Check fuel.	Out of fuel.	Add fuel and press priming bulb to fill carburetor.
	Bad fuel, trimmer stored without treating or draining gasoline, refueled with bad gasoline.	Drain fuel tank and carburetor, refuel with fresh gasoline.
Remove spark plug.	Spark plug faulty, fouled, or has incorrect gap.	Clean, gap, or replace the spark plug.
Take trimmer to an authorized Honda servicing dealer, or refer to shop manual.	Fuel filter clogged, carburetor malfunction, ignition malfunction, valves stuck, etc.	Replace or repair faulty components as needed.

ENGINE OPERATING PROBLEMS

Low Power or Engine Speed Won't Increase	Possible Cause	Correction
Check air filter.	Filter dirty or clogged.	Check, clean or replace air filter.
Check fuel filter.	Filter dirty or clogged.	Replace fuel filter.
Check throttle cable.	Out of adjustment, broken, or bent.	Adjust cable, or replace if necessary.
Check spark arrester.	Screen clogged.	Clean screen.
Check gear case.	Grass wrapped around output shaft and/or cutting attachment.	Move the ignition switch to the STOP (O) position and disconnect the spark plug cap from the spark plug. Remove grass from the output shaft and cutting attachment area.

TAKING CARE OF UNEXPECTED PROBLEMS

CUTTING HEAD PROBLEMS

Blade or Cutting-line head Won't Stop Turning When Throttle is at SLOW Position	Possible Cause	Correction
Check throttle control and cable.	Fault in throttle control or cable; throttle cable out of adjustment or bent.	Check throttle control parts, adjust or replace cable if necessary.
	Idle speed is too fast.	Adjust idle speed.
Check clutch.	Clutch springs broken or worn, or clutch system faulty.	Replace clutch springs or replace or repair other clutch system parts.

Blade or Cutting-Line Head Won't Turn	Possible Cause	Correction
Check clutch, drive cable, and gear case.	Worn or broken clutch, broken cable, worn or broken gear case parts.	Replace or repair faulty components as needed.

Excessive Vibration	Possible Cause	Correction
Check cutting-line head or blade nut.	Cutting-line head or blade nut loose.	Tighten cutting-line head or blade nut securely.
Check blade.	Blade damaged.	Replace blade.

TECHNICAL & CONSUMER INFORMATION

TECHNICAL INFORMATION

This chapter contains important information about serial number locations, high altitude operation, oxygenated fuels, and emissions control systems.

Serial Number Locations

There are two serial numbers, one for the trimmer and one for the engine. Record these numbers in the space provided. You will need to have these numbers available when ordering parts or making technical or warranty inquiries (page 60).

Engine Serial number: _____ Frame Serial number: _____

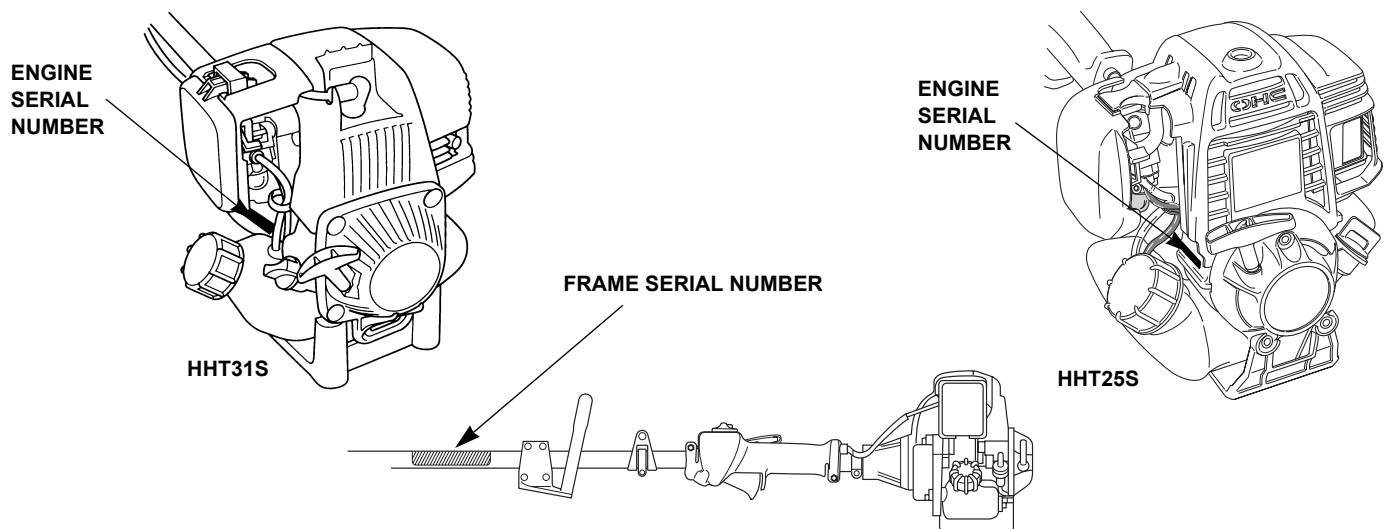

Carburetor Modifications for High Altitude Operation

At high altitude, the standard carburetor air-fuel mixture will be too rich. Performance will decrease, and fuel consumption will increase. A very rich mixture will also foul the spark plug and cause hard starting. Operation at an altitude that differs from that at which this engine was certified, for extended periods of time, may increase emissions.

High altitude performance can be improved by specific modifications to the carburetor. If you always operate your trimmer at altitudes above 5,000 feet (1,500 meters), have your servicing dealer perform this carburetor modification. This engine, when operated at high altitude with the carburetor modifications for high altitude use, will meet each emission standard throughout its useful life.

Even with carburetor modification, engine horsepower will decrease about 3.5% for each 1,000-foot (300-meter) increase in altitude. The effect of altitude on horsepower will be greater than this if no carburetor modification is made.

NOTICE

When the carburetor has been modified for high altitude operation, the air-fuel mixture will be too lean for low altitude use. Operation at altitudes below 5,000 feet (1,500 meters) with a modified carburetor may cause the engine to overheat and result in serious engine damage. For use at low altitudes, have your servicing dealer return the carburetor to original factory specifications.

Oxygenated Fuels

Some conventional gasolines are being blended with alcohol or an ether compound. These gasolines are collectively referred to as oxygenated fuels. To meet clean air standards, some areas of the USA and Canada use oxygenated fuels to help reduce emissions. If you use an oxygenated fuel, be sure it is unleaded and meets the minimum octane rating requirement. Before using an oxygenated fuel, try to confirm the fuel's contents. Some states/provinces require this information to be posted on the pump.

The following are the EPA approved percentages of oxygenates:

ETHANOL — (ethyl or grain alcohol) 10% by volume

You may use gasoline containing up to 10% ethanol by volume. Gasoline containing ethanol may be marketed under the name "Gasohol."

MTBE — (Methyl Tertiary Butyl Ether) 15% by volume

You may use gasoline containing up to 15% MTBE by volume.

METHANOL — (methyl or wood alcohol) 5% by volume

You may use gasoline containing up to 5% methanol by volume, as long as it also contains cosolvents and corrosion inhibitors to protect the fuel system. Gasoline containing more than 5% methanol by volume may cause starting and/or performance problems. It may also damage metal, rubber, and plastic parts of your fuel system.

If you notice any undesirable operating symptoms, try another service station or switch to another brand of gasoline. Fuel system damage or performance problems resulting from the use of an oxygenated fuel containing more than the percentages of oxygenates mentioned above are not covered under the *Distributor's Limited Warranty*.

TECHNICAL & CONSUMER INFORMATION

Emissions Control System Information

Source of Emissions

The combustion process produces carbon monoxide, oxides of nitrogen, and hydrocarbons. Control of hydrocarbons and oxides of nitrogen is very important because, under certain conditions, they react to form photochemical smog when subjected to sunlight. Carbon monoxide does not react in the same way, but it is toxic.

Honda utilizes lean carburetor settings and other systems to reduce the emissions of carbon monoxide, oxides of nitrogen, and hydrocarbons.

The U.S. and California Clean Air Acts

EPA and California regulations require all manufacturers to furnish written instructions describing the operation and maintenance of emissions control systems.

The following instructions and procedures must be followed in order to keep the emissions from your Honda engine within the emissions standards.

Tampering and Altering

Tampering with or altering the emissions control system may increase emissions beyond the legal limit. Among those acts that constitute tampering are:

Removal or alteration of any part of the intake, fuel, or exhaust systems.

Altering or defeating the speed-adjusting mechanism to cause the engine to operate outside its design parameters.

Problems That May Affect Emissions

If you are aware of any of the following symptoms, have your engine inspected and repaired by your servicing dealer.

- Hard starting or stalling after starting
- Rough idle
- Misfiring or backfiring under load
- Afterburning (backfiring)
- Black exhaust smoke or high fuel consumption

Replacement Parts

The emissions control systems on your new Honda engine were designed, built, and certified to conform with EPA and California emissions regulations. We recommend the use of genuine Honda parts whenever you have maintenance done. These original-design replacement parts are manufactured to the same standards as the original parts, so you can be confident of their performance. The use of replacement parts that are not of the original design and quality may impair the effectiveness of your emissions control system.

A manufacturer of an aftermarket part assumes the responsibility that the part will not adversely affect emissions performance. The manufacturer or rebuilder of the part must certify that use of the part will not result in a failure of the engine to comply with emissions regulations.

Maintenance

Follow the MAINTENANCE SCHEDULE on page 25. Remember this schedule is based on the assumption that your machine will be used for its designed purpose. Sustained high-load or high-temperature operation, or use in unusually wet or dusty conditions, will require more frequent service.

TECHNICAL & CONSUMER INFORMATION

Air Index

An Air Index Information hang tag/label is applied to engines certified to an emission durability time period in accordance with the requirements of the California Air Resources Board.

The bar graph is intended to provide you, our customer, the ability to compare the emissions performance of available engines. The lower the Air Index, the less pollution.

The durability description is intended to provide you with information relating the engine's emission durability period. The descriptive term indicates the useful life period for the engine's emission control system. See your *Emission Control System Warranty* for additional information.

Descriptive Term	Applicable to Emissions Durability Period
Moderate	50 hours (0–65 cc) 125 hours (greater than 65 cc)
Intermediate	125 hours (0–65 cc) 250 hours (greater than 65 cc)
Extended	300 hours (0–65 cc) 500 hours (greater than 65 cc)

The Air Index Information hang tag/label must remain on the trimmer/brush cutter until it is sold. Remove the hang tag before operating the trimmer/brush cutter.

TECHNICAL & CONSUMER INFORMATION

Specifications

FEATURES			
	HHT25S	HHT31S	HHT31SUNBA
GX25 1.1 hp	•		
GX31 1.5 hp		•	•
Loop handle	•	•	
U-type handle			•
Manual feed head	optional	optional	•
Semi-matic feed head	•	•	optional
Saw blade	optional (requires optional Barrier Kit)	optional (requires optional Barrier Kit)	•

DIMENSIONS				
	Handle Installed		HHT25S	HHT31S
Length	Loop	Manual feed head	—	6.15 feet (1.875 m)
		Semi-matic feed head	6.12 feet (1.867 m)	6.18 feet (1.885 m)
	U-type ¹		—	6.27 feet (1.91 m)
Width	Loop		12.8 in (324 mm)	
	U-type		—	22.8 in (581 mm)
Height	Loop		9.6 in (245 mm)	10.6 in (270 mm)
	U-type		—	14.6 in (372 mm)
Dry weight	Loop		13.0 lb. (5.89 kg)	14.7 lb. (6.67 kg)
	U-type		—	15.5 lb. (7.03 kg)

¹with saw blade installed

TECHNICAL & CONSUMER INFORMATION

ENGINE		
	HHT25S	HHT31S
Model	GX25	GX31
Engine type	4-stroke, overhead-cam, single-cylinder	
Displacement	1.5 cu in (25 cc)	1.9 cu in (31 cc)
Bore & stroke	1.4 x 1.0 in (35 x 26 mm)	1.5 x 1.0 in (39 x 26 mm)
Maximum output	1.1 hp (0.82 kW) at 7,000 rpm	1.5 hp (1.1 kW) at 7,000 rpm
Maximum torque	0.8 ft-lbs (1.09 N•m) at 5,000 rpm	1.23 ft-lbs (1.64 N•m) at 4,500 rpm
Ignition system	Transistorized magneto	
Spark plugs	NGK: CMR5H	NGK: CR5HSB or DENSO: U16FSR-UB
Starting system	Recoil	
Fuel	Unleaded gasoline (86 octane or higher)	
Fuel tank capacity	0.53 qt/16.9 fl.oz (0.50 ℓ)	0.69 qt/22.0 fl oz (0.65 ℓ)
Fuel consumption	0.61 lb/hph (370 g/kWh, 276 g/psh)	0.55 lb/hph (340 g/kWh, 250 g/psh)
Oil capacity	2.7 fl oz (80 cc)	3.4 fl oz (100 cc)
Carburetor type	Diaphragm type (overflow return) with fuel pump	
Air cleaner	Single element, semi-dry	
Idle speed	3,100 ± 200 rpm	

FRAME				
		HHT25S	HHT31S	
Ignition switch		Slide type		
Throttle control		Two-motion trigger style		
Frame pipe	OD	1.0 in (25.4 mm)		
	Thickness	0.059 in (1.5 mm)		
Drive	Type	Material	Flexible steel cable	
		OD	0.25 in (6.3 mm)	
	Bushing	Engagement	0.20 in (5 mm) square drive both ends	
		Material	Nylon	
Gear case	Length	57-1/2 inch (1460 mm)		
	Ratio	1.24 (input shaft) : 1 (output shaft)		
Clutch	Type	Ball bearings, helical cut gears, no shims required		
	Size	2-1/8 inch	3-1/16 inch	
	Engagement	4,200 ± 200 rpm		
	Drive	Square female		
	Type	Centrifugal		

Tuneup

ITEM		SPECIFICATION	MAINTENANCE
Spark plug gap		0.024 - 0.028 in (0.60 - 0.70 mm)	Refer to page 37
Valve clearance (cold)	HHT25S	Intake: 0.08 ± 0.02 mm Exhaust: 0.11 ± 0.02 mm	See your authorized servicing Honda dealer
	HHT31S	Intake: 0.12 ± 0.02 mm Exhaust: 0.15 ± 0.02 mm	

TECHNICAL & CONSUMER INFORMATION

CONSUMER INFORMATION

Dealer Locator Information

To find an Authorized Honda Servicing Dealer anywhere in the United States:

Call (800) 426-7701

or visit our website:

www.hondapowerequipment.com/dealer

Warranty Service Information

Honda Power Equipment dealership personnel are trained professionals. They should be able to answer any question you may have. If you encounter a problem that your dealer does not solve to your satisfaction, please discuss it with the dealership's management. The Service Manager or General Manager can help. Almost all problems are solved in this way.

If you are dissatisfied with the decision made by the dealership's management, contact the Honda Power Equipment Customer Service Office. You can write:

American Honda Motor Co., Inc.
Power Equipment Division
Customer Service Office
4900 Marconi Drive
Alpharetta, GA 30005-8847

Or telephone: (770) 497-6400

When you write or call, please give us this information:

- Model and serial numbers (see page 54)
- Name of the dealer who sold the trimmer to you
- Name and address of the dealer who services your trimmer
- Date of purchase
- Your name, address, and telephone number
- A detailed description of the problem

Honda Publications

Three other documents are available from your Honda dealer. There is a shop manual and shop manual supplement, which covers complete maintenance and overhaul procedures. It is intended to be used by a skilled technician. There is also a parts catalog that provides a complete, illustrated parts list.

Replacement Parts and Service Items

Contact an authorized Honda servicing dealer to purchase genuine, original Honda items for your trimmer.

INDEX

A

Air Filter	
Check	27
Cleaning	27
Air Index.....	57
Assembly	42
Loose Parts	43
Trimmer Assembly (UNBA types only).....	44
Unpacking	43

B

Before Operation	14
Blade	
Inspection	35
Removal and Installation	35
Blade Thrust	22
Brush/Wood Blade Cover	
Installation and Removal	9

C

Carburetor Modifications for High Altitude	
Operation	54
Choke Lever	11
Clothing Recommendations.....	4
Consumer Information	60
Cooling Fin Inspection	41
Cutting Attachments	
Applications	9
Blades and Shields.....	8
Inspection	29
Installing Replacement Line	29
Recommendations	7
Cutting Head	
Problems	53
Replacing Bump Feed Head	32
Replacing Manual Feed Head.....	30

D

Damage Prevention Message Definition	1
Debris Shield	
Changing	36
Description of Controls	11

E

Emission Control System.....	56
Engine	
Fuel Recommendations.....	40
Ignition Switch	11
Oil Change.....	26
Oil Level.....	26
Oil Recommendations	27
Operating Problems.....	52
Priming Bulb	12
Serial Number.....	54

F

Frame Serial Number.....	54
Fuel	
Additive to Extend Storage Life	50
Draining	50
Gasoline Recommendations	40
Refueling	40

G

Gasoline Recommendations	40
--------------------------------	----

I

Ignition Switch	11
Inspection Before Trimming/Cutting	
Shoulder Harness	16
Trimmer/Cutter	15
Trimming/Cutting Area.....	14

K

Kickback.....	22
---------------	----

L

Loop Handle	
Installing Safety Equipment	21
Metal Blade and Barrier Kit.....	8

INDEX

M

Maintenance	
Air Filter	27
Engine Oil	26
Fuel System	40
Importance	24
Safety	24
Schedule	25
Spark Arrester	38
Spark Plug	37
Throttle Cable	28

O

Oil, Engine	
Changing	26
Level Check	26
Recommendations	27
Operating the Trimmer	17
Brush Clearing	23
Scything	22
Slopes	23
Tips	22
Operator Presence Lever	11
Oxygenated Fuels	55

P

Priming Bulb	12
--------------------	----

R

Recoil Starter	12
----------------------	----

S

Safe Operating Practices	21
Safety	
Attachments and Modifications	5
Important Message to Employers	5
Important Safety Information	4
Safety Label Locations	6
Safety Precautions	17
Serial Numbers	54
Shoulder Harness	13
Adjustment	16
Quick Disconnection	19
Quick Release Latch	13
Spark Arrester Service	38
Spark Plug Service	37
Specifications	58
Starting Problems	52
Starting the Engine	17
Stopping the Engine	19
Storage	49

T

Taking Care of Unexpected Problems	52
Throttle	
Cable Inspection/Adjustment	28
Operation	11 & 20
Transporting	51
Trimmer Head	
Removing/Installing	34

W

Warranty Service Information	60
------------------------------------	----

QUICK REFERENCE INFORMATION

		HHT25S	HHT31S
Fuel	Type	Unleaded gasoline with a pump octane rating of 86 or higher (page 40)	
	Capacity	0.53 qt/16.9 fl oz (0.50ℓ)	0.69 qt/22.0 fl oz (0.65ℓ)
Engine oil	Type	SAE 10W-30, API SJ or SL (page 27)	
	Capacity	2.71 fl oz (80 cc)	3.4 fl oz (100 cc)
Spark plug	Type	NGK: CMR5H	NGK: CR5HSB DENSO: U16FSR-UB
	Electrode gap	0.024 – 0.028 in (0.60 – 0.70 mm)	
Carburetor	Idle speed	3,100 ± 200 rpm	
Maintenance	Before each use	Check engine oil (page 26) Check air filter (page 27) Check throttle cable (page 28) Check cutting attachment (pages 30 and 32) Check debris shield (pages 29 and 36) Check nuts, bolts, fasteners Check shoulder harness, quick release (page 19)	
	First 10 hours	Change engine oil (page 26)	
	Subsequent	Refer to the Maintenance Schedule (page 25)	

HONDA

The power of dreams.™

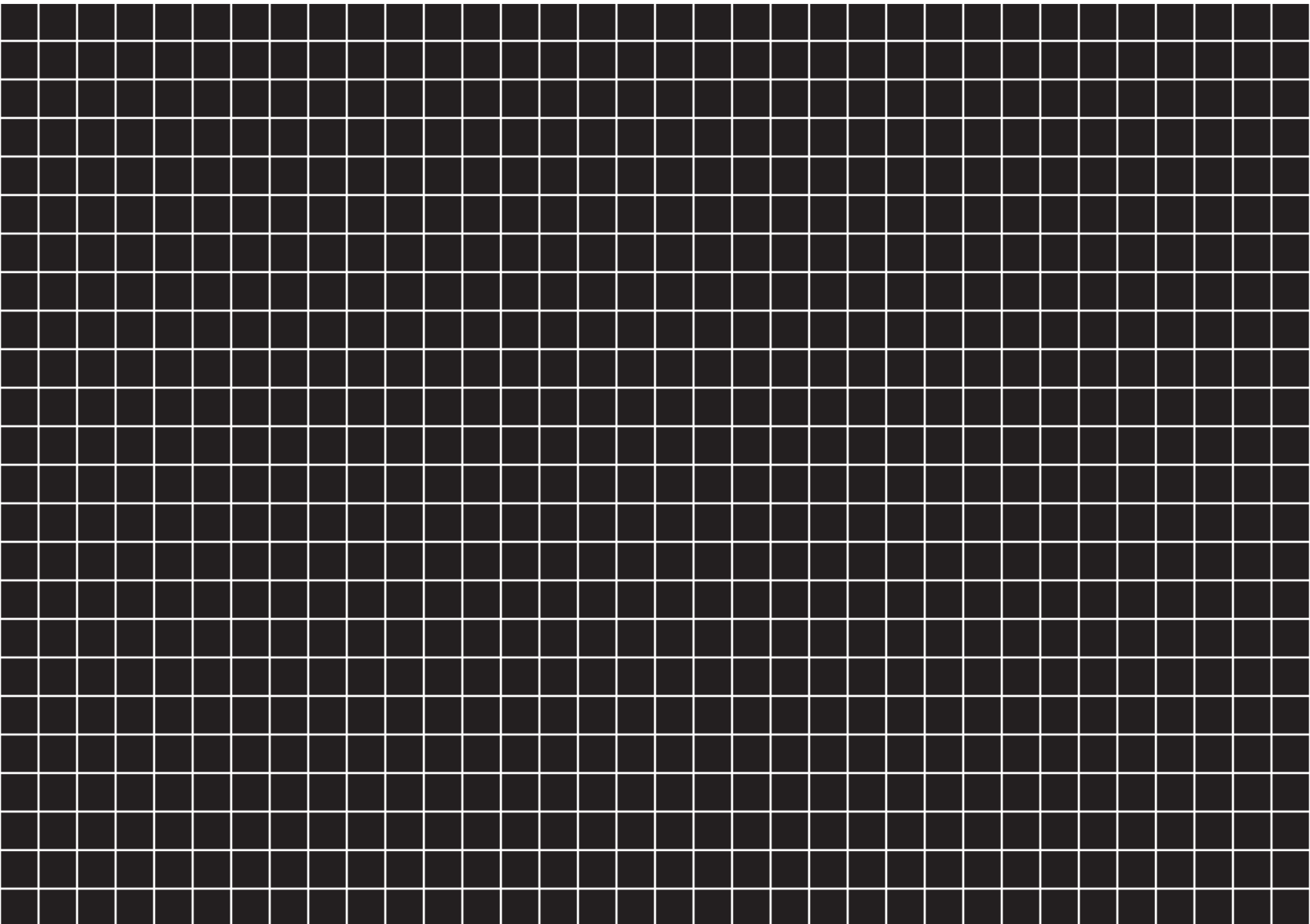

31VJ4000
00X31-VJ4-0000



Printed on
Recycled Paper



POM53509
IPC 10000.2002.10
Printed in U.S.A.