

**HONDA**

**Power**

**Equipment**

# Owner's Manual

## Trimmer/Brush Cutter

### HHT25S • HHT35S

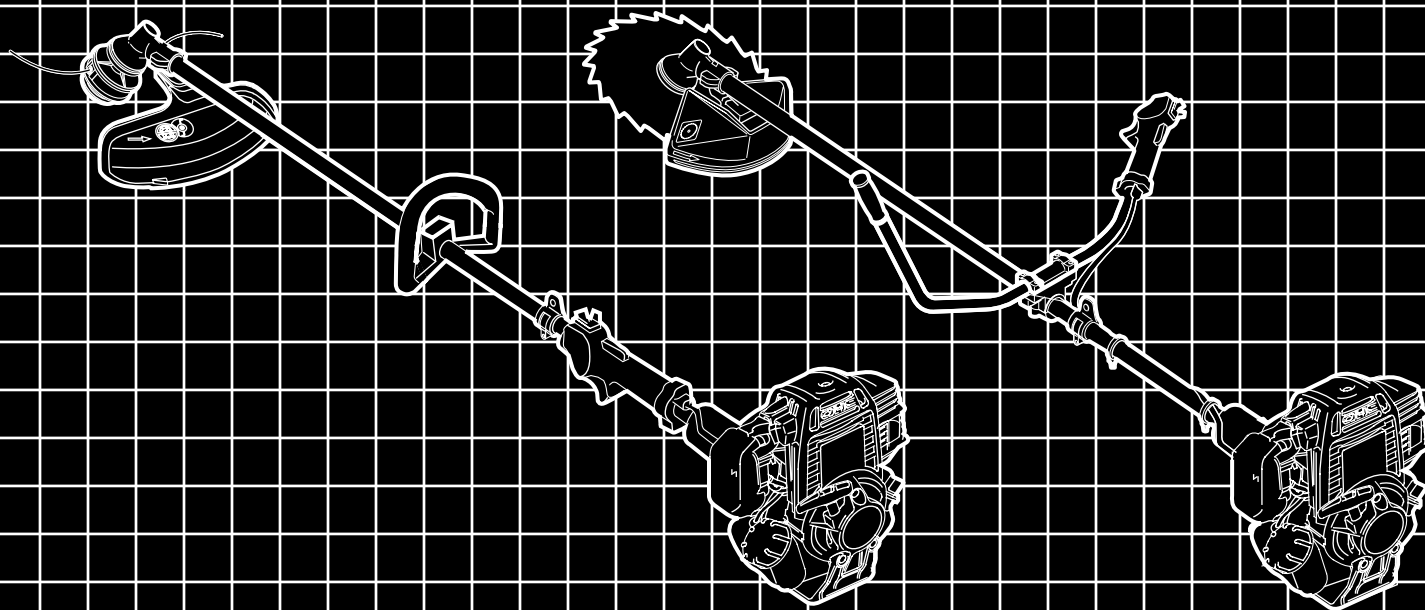

*See page 41 for instructions on  
assembling your Trimmer.*



## **WARNING:**



The engine exhaust from this product contains chemicals known to the State of California to cause cancer, birth defects or other reproductive harm.

Keep this owner's manual handy, so you can refer to it at any time. This owner's manual is considered a permanent part of the trimmer/brush cutter and should remain with the trimmer/brush cutter if resold.

The information and specifications included in this publication were in effect at the time of approval for printing. American Honda Motor Co., Inc. reserves the right, however, to discontinue or change specifications or design at any time without notice and without incurring any obligation whatever. No part of this publication may be reproduced without written permission.

# INTRODUCTION

Congratulations on your selection of a Honda trimmer/brush cutter! We are certain you will be pleased with your purchase of one of the finest trimmer/brush cutters on the market.

We want to help you get the best results from your new trimmer/brush cutter and to operate it safely. This manual contains the information on how to do that; please read it carefully.

As you read this manual, you will find information preceded by a **NOTICE** symbol. That information is intended to help you avoid damage to your trimmer/brush cutter, other property, or the environment.

We suggest you read the *Distributor's Limited Warranty* (page 60) and the *Emission Control System Warranty* (page 62) to fully understand its coverage and your responsibilities of ownership.

When your trimmer/brush cutter needs scheduled maintenance, keep in mind that your Honda servicing dealer is specially trained in servicing Honda trimmers/brush cutters. Your Honda servicing dealer is dedicated to your satisfaction, and will be pleased to answer your questions and concerns.

Best Wishes,

Power Equipment Division  
American Honda Motor Co., Inc.

# INTRODUCTION

---

## A FEW WORDS ABOUT SAFETY

Your safety and the safety of others are very important, and using this trimmer/brush cutter safely is an important responsibility.

To help you make informed decisions about safety, we have provided operating procedures and other information on labels and in this manual. This information alerts you to potential hazards that could hurt you or others.

Of course, it is not practical or possible to warn you about all the hazards associated with operating or maintaining a trimmer/brush cutter. You must use your own good judgment.

You will find important safety information in a variety of forms, including:

- **Safety Labels**—on the trimmer/brush cutter.
- **Safety Messages**—preceded by a safety alert symbol  and one of three signal words, DANGER, WARNING, or CAUTION.

These signal words mean:

 **DANGER**

You **WILL** be KILLED or SERIOUSLY HURT if you don't follow instructions.

 **WARNING**

You **CAN** be KILLED or SERIOUSLY HURT if you don't follow instructions.

 **CAUTION**

You **CAN** be HURT if you don't follow instructions.

- **Safety Headings**—such as *IMPORTANT SAFETY INFORMATION*.
- **Safety Section**—such as *TRIMMER SAFETY*.
- **Instructions**—how to use this trimmer/brush cutter correctly and safely.

This entire book is filled with important safety information—please read it carefully.

# CONTENTS

<b>TRIMMER SAFETY</b> .....	4	<b>STORAGE</b> .....	48
IMPORTANT SAFETY INFORMATION .....	4	STORAGE PREPARATION.....	48
ATTACHMENTS & MODIFICATIONS.....	5	STORAGE PRECAUTIONS .....	49
IMPORTANT MESSAGE TO EMPLOYERS .....	5	REMOVAL FROM STORAGE .....	49
SAFETY LABEL LOCATIONS.....	6	<b>TRANSPORTING</b> .....	50
<b>RECOMMENDED CUTTING ATTACHMENTS</b> .....	7	<b>TAKING CARE OF UNEXPECTED PROBLEMS</b> .....	51
CUTTING-LINE HEADS AND SHIELDS .....	7	<b>TECHNICAL &amp; CONSUMER INFORMATION</b> .....	53
BLADES AND SHIELDS .....	8	TECHNICAL INFORMATION .....	53
CUTTING ATTACHMENT APPLICATIONS.....	9	EMISSION CONTROL SYSTEM.....	55
<b>CONTROLS &amp; EQUIPMENT</b> .....	10	SPECIFICATIONS .....	57
CONTROLS.....	11	<b>INDEX</b> .....	63
EQUIPMENT .....	13	<b>QUICK REFERENCE INFORMATION</b> .....	65
<b>BEFORE OPERATION</b> .....	14		
IS YOUR WORKING AREA READY? .....	14		
<b>OPERATION</b> .....	17		
SAFE OPERATING PRECAUTIONS .....	17		
STARTING THE ENGINE .....	17		
STOPPING THE ENGINE .....	19		
TRIMMER/HARNESS QUICK DISCONNECTION.....	19		
TRIMMER OPERATION.....	19		
SAFE OPERATING PRACTICES .....	21		
OPERATING TIPS .....	22		
<b>SERVICING YOUR TRIMMER</b> .....	24		
THE IMPORTANCE OF MAINTENANCE .....	24		
MAINTENANCE SAFETY .....	24		
MAINTENANCE SCHEDULE .....	25		
ENGINE.....	26		
CUTTING ATTACHMENTS.....	29		
FUEL SYSTEM.....	39		
<b>ASSEMBLY</b> .....	41		
IMPORTANCE OF PROPER ASSEMBLY .....	41		
IMPORTANT SAFETY PRECAUTIONS .....	41		
UNPACKING .....	42		
LOOSE PARTS .....	42		
TRIMMER ASSEMBLY .....	43		
BLADE COVER REMOVAL .....	46		
BLADE COVER INSTALLATION .....	46		
ENGINE OIL.....	47		
BEFORE OPERATION.....	47		

# TRIMMER SAFETY

## IMPORTANT SAFETY INFORMATION

The Honda HHT25S and HHT35S trimmer/brush cutters are designed to cut grass, weeds, brush, and/or wood if equipped with an appropriate cutting attachment. Other uses can result in injury to the operator or damage to the trimmer and other property.

These Honda trimmers are intended for use by gardening professionals. Never allow children to operate the trimmer.

Most accidents can be prevented if you follow all instructions in this manual and on the trimmer. The most common hazards are discussed below, along with the best way to protect yourself and others.

### Always Wear Eye Protection and Protective Clothing

- The most frequent injuries associated with string trimmers are eye injuries caused by thrown debris. Always wear safety glasses or goggles that meet the ANSI Z87.1 rating whenever you use the trimmer.
- The operator must wear hearing protectors when using this trimmer. Hearing protectors will protect the operator's ears from noise damage.
- Wearing protective clothing also reduces the risk and severity of injury from thrown debris or contact with the cutting attachment. Wear the trimmer harness, gloves, a long-sleeved shirt, long pants, and sturdy boots with nonslip soles.  
See page 14 for more information.

### Keep Away From Cutting Lines and Blades

- A spinning cutting blade can cut through your clothes and skin just as easily as it cuts through grass and dirt. Keep all parts of your body away from a spinning cutting attachment.
- Even after the engine has stopped, the cutting attachment will spin for several seconds. Do not touch it until it has stopped spinning, or you may get cut.

### Turn the Engine Off When Not Trimming

If you stop trimming or cutting for any reason, even to clean off the cutting attachment, always shut off the engine.

### Keep People Away From Your Working Area

To prevent injury to others, keep people at least 50 feet (15 meters) away from the working area during operation.

### Always Wear the Harness When Trimming

The harness keeps the trimmer away from your body, lowering your chances of being cut by the trimmer's blade or cutting line.

### Read This Manual Before Using the Trimmer

Read the manual before operating the trimmer. Understand how to use all the controls and obey all warnings.

### Clear the Working Area First

Objects thrown by the trimmer can cause serious injury. Before operating the trimmer, carefully inspect the area and remove any broken glass, pieces of wire, and other loose objects.

### Keep the Trimmer Properly Maintained

- The cutting attachment should be examined for looseness, cracks, broken parts, or excessive wear. Tighten or replace as needed before operating the trimmer.
- Do not operate the trimmer without a debris shield properly installed. Make sure you have the right shield installed for your cutting attachment.  
For more information, see pages 7 and 8.

## ATTACHMENTS & MODIFICATIONS

Modifying your trimmer/brush cutter, or installing non-Honda attachments, can make your trimmer unsafe. Before you make any modifications or install any attachments, be sure to read the following information.

### Attachments

Your Honda trimmer servicing dealer has cutting attachments, debris shields, barrier kits, and shoulder harnesses that have been designed and approved for your trimmer and are covered by warranty.

Non-Honda attachments are usually designed for universal applications. Although aftermarket attachments may fit on your trimmer, they may not meet factory specifications and could make your trimmer unsafe.

### Modifications

Do not remove the debris shield or modify your trimmer in any way that would alter its design or operation. This could make your trimmer unsafe.

## IMPORTANT MESSAGE TO EMPLOYERS

As an employer, you have special responsibilities to the people who work for you.

Before you ask anyone to operate this trimmer/brush cutter, you need to determine whether the operator is old enough, large enough, and strong enough to safely handle and control the trimmer/brush cutter.

If you decide he/she is, make sure the employee(s) read and understand all instructions and warnings in this manual and on the labels before operating the trimmer/brush cutter.

Allow adequate time for hands-on training by a qualified instructor, and personally supervise practice sessions, until you feel sure the employee is ready to operate the trimmer/brush cutter.

Also be sure employees wear proper clothing, eye and hearing protection, and any other gear that may be required by local ordinances or your insurance company.



Remember, too, that you are responsible for keeping the trimmer/brush cutter properly maintained and in safe operating condition.

Your commitment to safety on the job can help prevent accidents and result in longer and more productive years of service.

# TRIMMER SAFETY

## SAFETY LABEL LOCATIONS

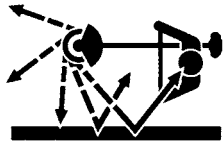
The labels shown here contain important safety information. Please read them carefully. These labels are considered permanent parts of your trimmer/brush cutter. If a label comes off or becomes hard to read, contact an authorized Honda servicing dealer for a replacement.

<b>⚠ WARNING</b>	
	<b>READ AND FOLLOW OWNER'S MANUAL.</b> Failure to do so can result in serious injury to the operator and bystanders.
<b>⚠ WARNING</b>	
	<b>OBJECTS THROWN BY CUTTING ATTACHMENTS CAN CAUSE SERIOUS INJURY.</b> <ul style="list-style-type: none"><li>■ Always wear eye protection that meets ANSI Z87.1.</li><li>■ Always wear hearing protection and protective clothing.</li><li>■ Keep bystanders at least 50 feet (15m) away.</li><li>■ Do not operate without shield.</li></ul>
<b>⚠ WARNING</b>	
	<b>CONTACT WITH ROTATING CUTTING ATTACHMENT CAN CAUSE SERIOUS INJURY.</b> <ul style="list-style-type: none"><li>■ Keep away from rotating cutting attachment.</li><li>■ Be aware of possible kickback when using blades. (See Owner's Manual for special operating precautions)</li><li>■ Install proper shield, handle, and harness for cutting attachment.</li><li>■ Use only Honda recommended cutting attachments.</li></ul>

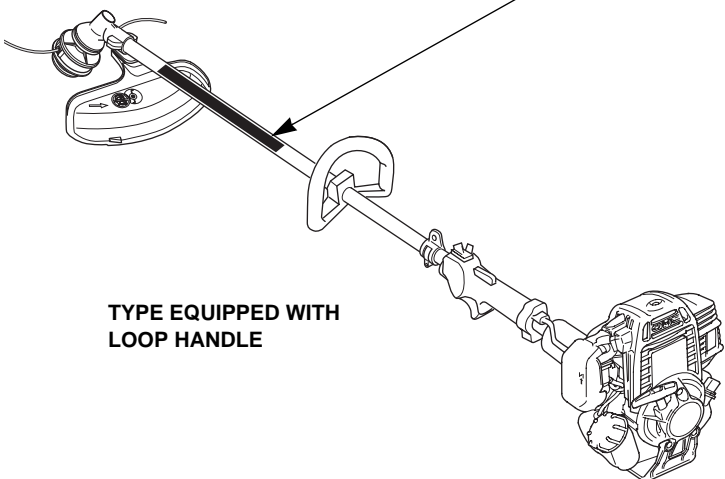

TYPE EQUIPPED WITH LOOP HANDLE

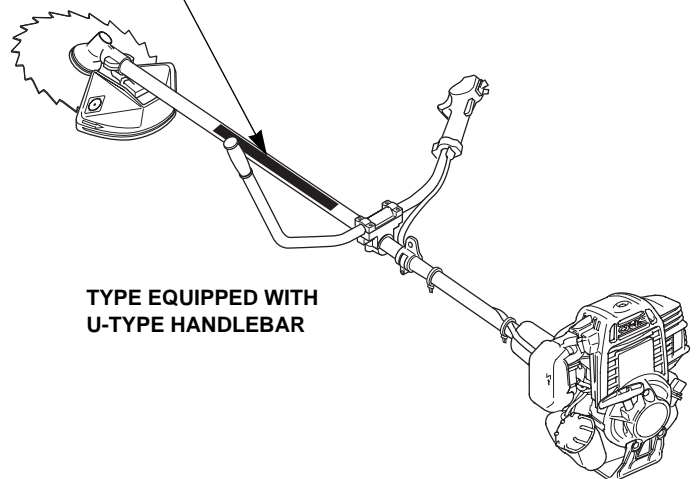

TYPE EQUIPPED WITH U-TYPE HANDLEBAR



# RECOMMENDED CUTTING ATTACHMENTS

## CUTTING-LINE HEADS AND SHIELDS

A cutting-line head containing nylon monofilament line and a debris shield with a cutoff knife is standard equipment. The shield's cutoff knife automatically removes any excess line that is released from the cutting head.

The U-type handlebar trimmers are supplied with two different debris shields. Use the debris shield with the cutoff knife when the cutting-line head is installed.

Nylon monofilament line is suitable for cutting grass and ordinary weeds, but not brush and woody growth.

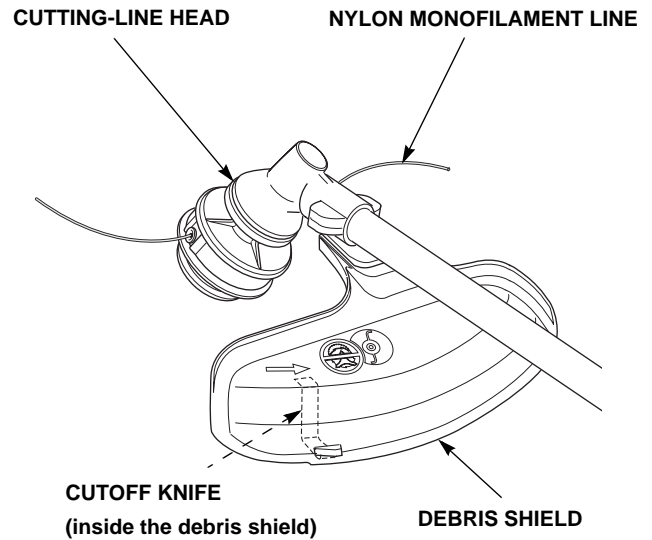

## Manual-Feed Cutting-Line Head

Line is released from the cutting head by manually pulling and turning the spool with the trimmer engine stopped.

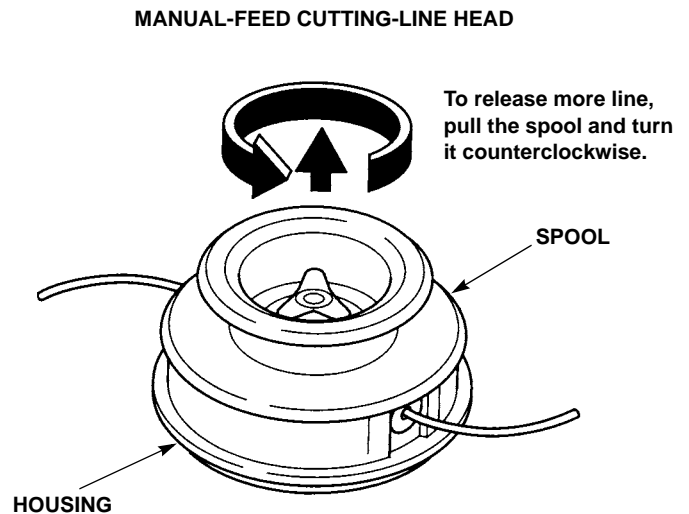

## Semi-Matic (bump-feed) Cutting-Line Head

Line is released from the cutting head by bumping the spool on hard ground while the head is spinning. Do not tap the cutting-line head on pavement or concrete.

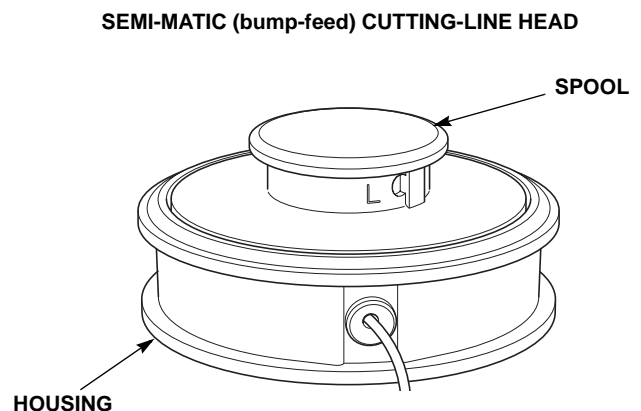

# RECOMMENDED CUTTING ATTACHMENTS

## BLADES AND SHIELDS

A variety of blades are available from your Honda trimmer servicing dealer. Always use a debris shield designed for use with a blade when attaching a blade to your trimmer. The blade type debris shield does not have a cutoff knife.

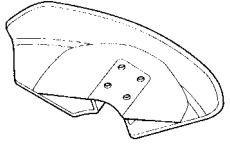
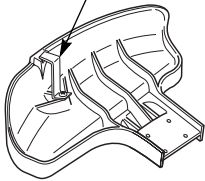
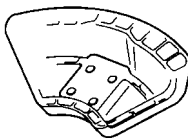
DEBRIS SHIELDS		
BLADE	CUTTING-LINE	
GRASS/WEED BLADE, WEED/BRUSH BLADE (optional part)		
BRUSH/WOOD BLADE		

Honda U-type handlebar trimmers are supplied with a blade cover surrounding the edge of the blade. For safety, and to protect the blade, the cover should be installed whenever the trimmer is not in use.

If installing a metal blade on a Honda trimmer equipped with a loop handle, also install the optional barrier kit that includes a full shoulder harness, a barrier bar, and a debris shield for metal blades. Follow the safety information and installation instructions that come with the kit.

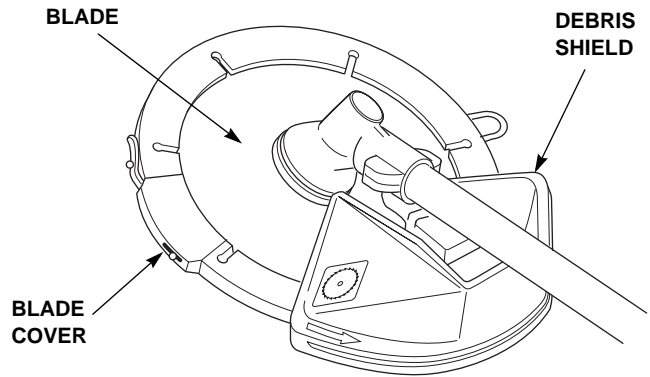

### Grass/Weed Blades

Grass/weed blades, which may be plastic or metal, are used as an alternative to nylon monofilament line for cutting grass and ordinary weeds.

However, blades should never be used for edging against solid surfaces.

### Weed/Brush Blades

These metal blades have chisel-shaped teeth that are used for cutting through field grass, thick weeds, and light brush. They are not designed for sawing woody material. The teeth must be sharp for good results.

### Brush/Wood Blades

These metal saw-tooth blades are used for sawing through saplings, shrubs and woody brush. The teeth must be sharp for good results. Brush/wood blades will also cut grass and weeds, but they are not efficient for that purpose.

GRASS/WEED BLADE

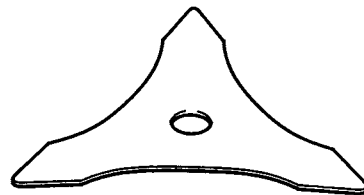

WEED/BRUSH BLADE

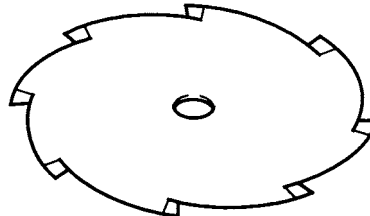

BRUSH/WOOD BLADE

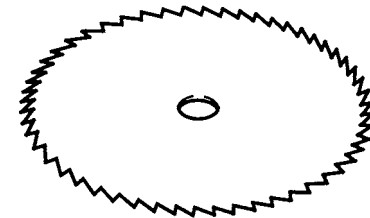

# RECOMMENDED CUTTING ATTACHMENTS

## Brush/Wood Blade Cover Installation and Removal

1. Install the blade cover over the blade so half the blade is covered.

To prevent the post end from interfering with the debris shield, pull the post end away from the blade and set it on top of the blade as shown.



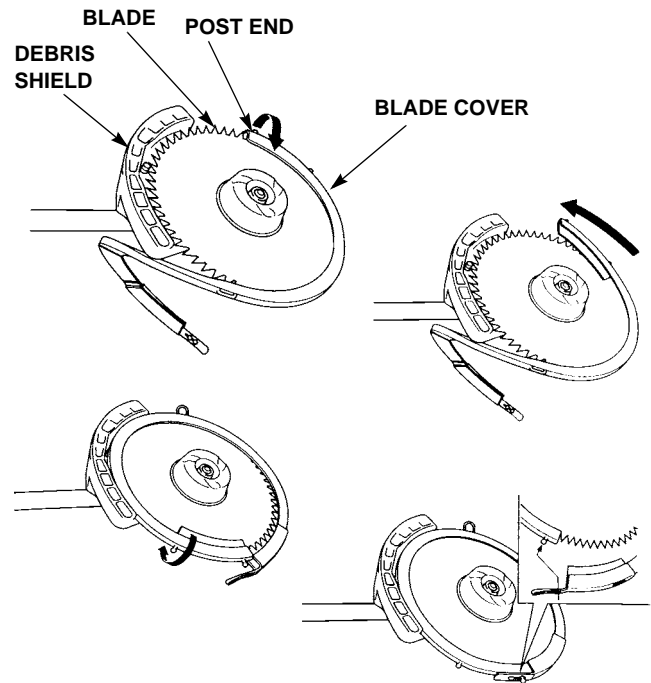

Turn the blade cover slowly until the post end clears the debris shield.

2. Reposition the post end over the blade.
3. With the blade cover fully seated on the blade, latch the tab over the post.

Remove the blade cover in the reverse order of installation.

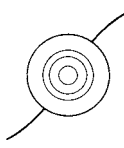
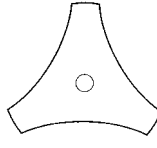
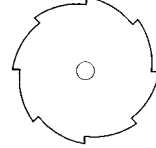
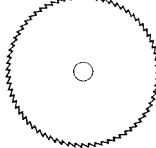

## CUTTING ATTACHMENT APPLICATIONS

	Line Size	Blade Diameter		
HHT25S	0.095"	9"		
HHT35S	0.095" or 0.105"	9" or 10"		
				
GRASS AND LIGHT WEEDS 	OK	OK	OK	NO
THICK WEEDS AND LIGHT BRUSH 	NO	NO	OK	NO
WOODY BRUSH, SHRUBS, SAPLINGS 	NO	NO	NO	OK

Your Honda trimmer servicing dealer has cutting attachments that have been designed and approved for your trimmer and are covered by warranty. Non-Honda attachments are usually designed for universal applications. Although aftermarket attachments may fit on your trimmer, they may not meet factory specifications and could make your trimmer unsafe.

# CONTROLS & EQUIPMENT

## COMPONENT & CONTROL LOCATIONS

### LOOP TYPE HANDLE

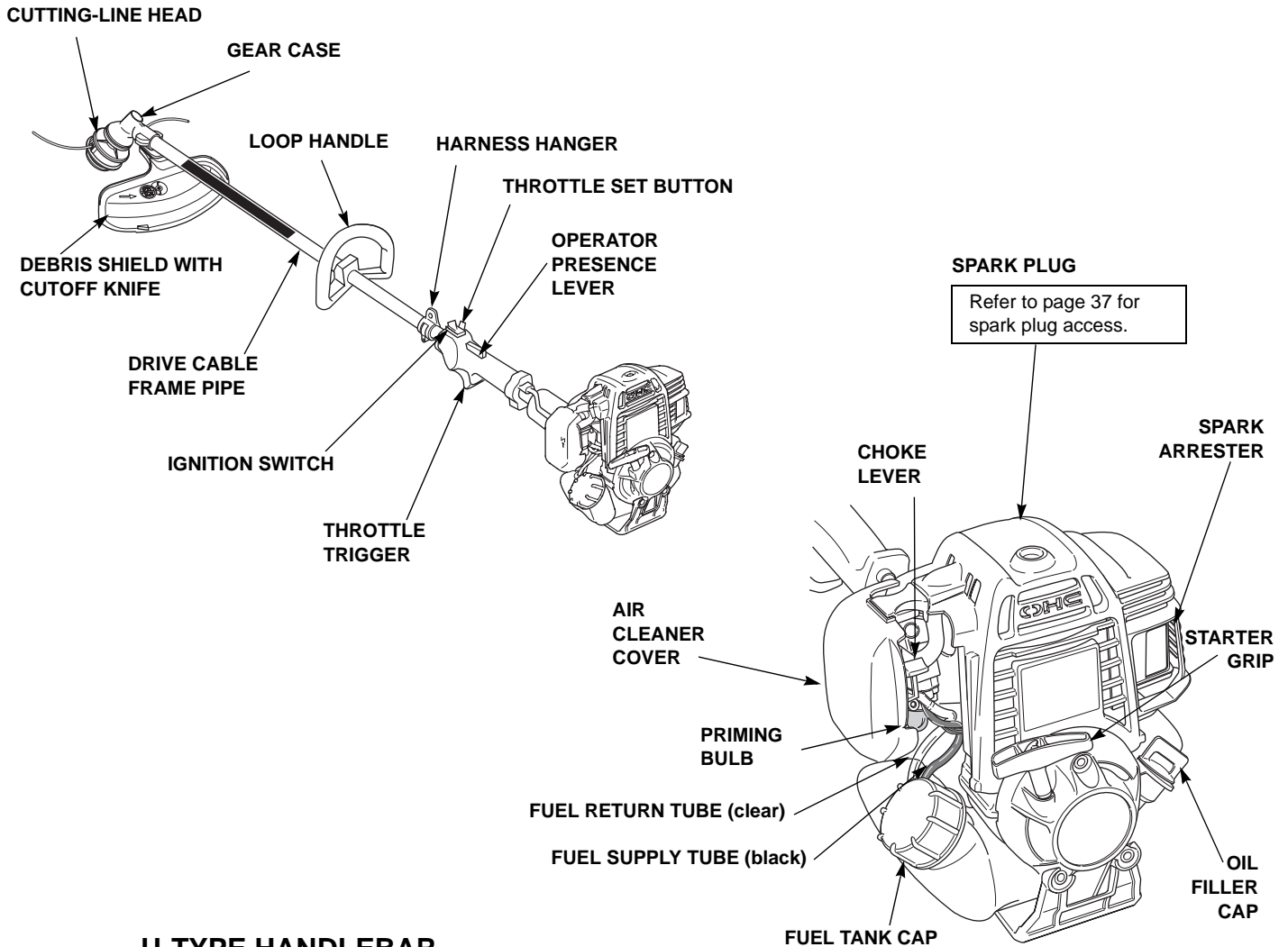

### U-TYPE HANDLEBAR

(supplied with a cutting-line head, a saw blade, and two debris shields)

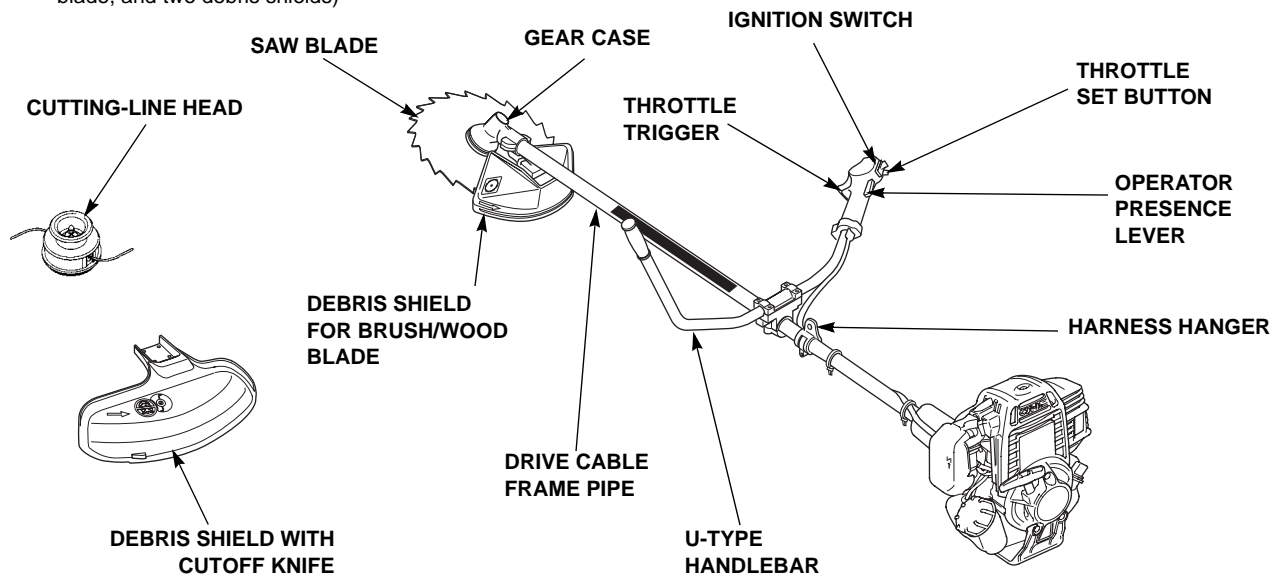

## CONTROLS

The location and operation of the controls are similar on both the HHT25S and HHT35S models.

### Choke Lever

The choke lever opens and closes the choke valve.

The CLOSED position enriches the fuel mixture for starting a cold engine.

The OPEN position provides the correct fuel mixture for operation after starting, and for restarting a warm engine.

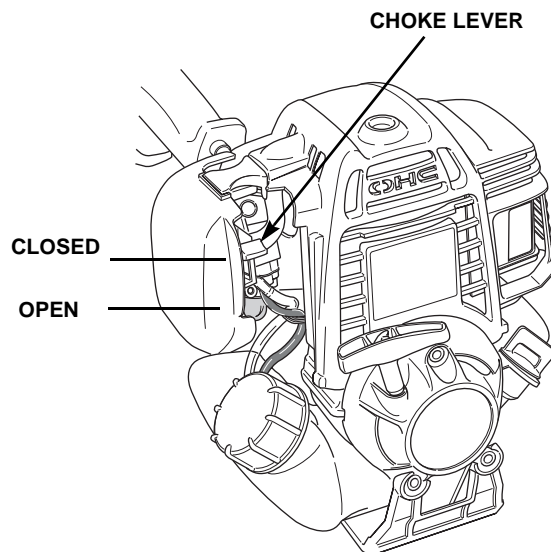

### Ignition Switch

The ignition switch controls the ignition system.

The ignition switch must be in the ON (I) position for the engine to start and run.

Moving the ignition switch to the STOP (O) position stops the engine.

### Operator Presence Lever

The operator presence lever blocks the throttle trigger. This safety feature prevents unintentional throttle operation if the trimmer is bumped while the operator's hand is not on the control handle.

When the operator presses the presence lever by gripping the control handle, the trigger moves freely.

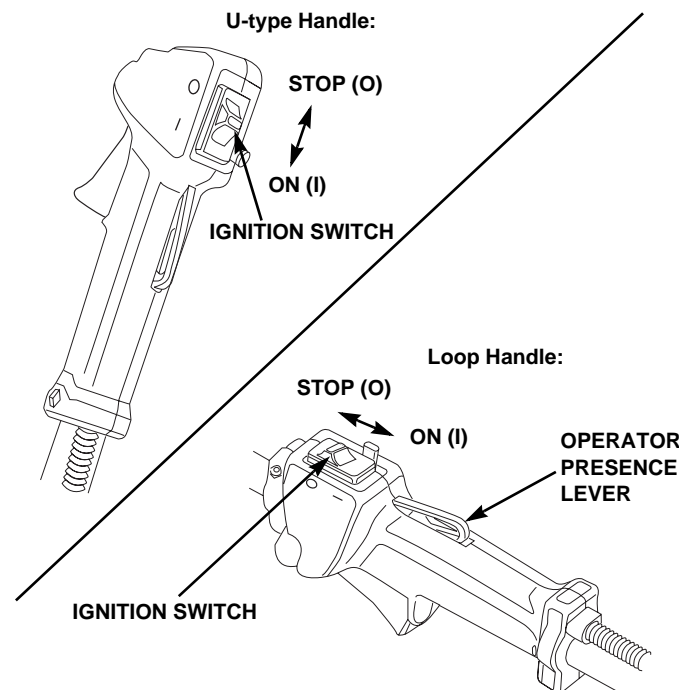

### Throttle Trigger

The throttle trigger controls engine speed.

Pulling the throttle trigger toward the control handle grip increases engine speed. The trimmer will have the greatest cutting force at maximum engine speed.

Releasing the throttle trigger reduces engine speed. At idle, the cutting attachment should coast to a stop.

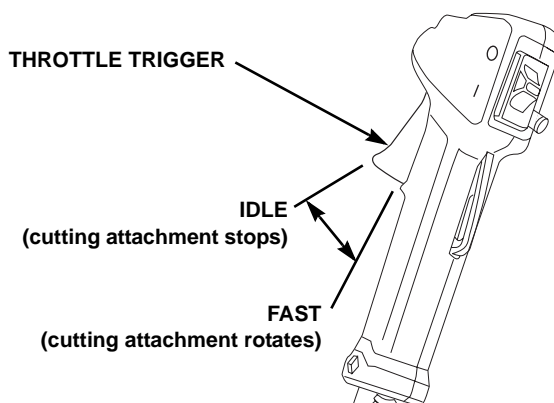

# CONTROLS & EQUIPMENT

## Throttle Set Button

The throttle set button is used to hold the throttle trigger at the fast idle position for starting. Do not allow the cutting line or blade to contact any obstruction when starting the engine with the throttle set button engaged.

To engage the throttle set button, press the operator presence lever by gripping the control handle, pull the throttle trigger, then press and hold the throttle set button while releasing the throttle trigger.

To disengage the throttle set button, simply pull the throttle trigger. The throttle set button automatically disengages when the throttle trigger is pulled.

Do not use the throttle set button while operating the trimmer. The trimmer will not return to idle, and the cutting-line head or blade will continue to spin until the throttle set button is disengaged and the throttle trigger is released.

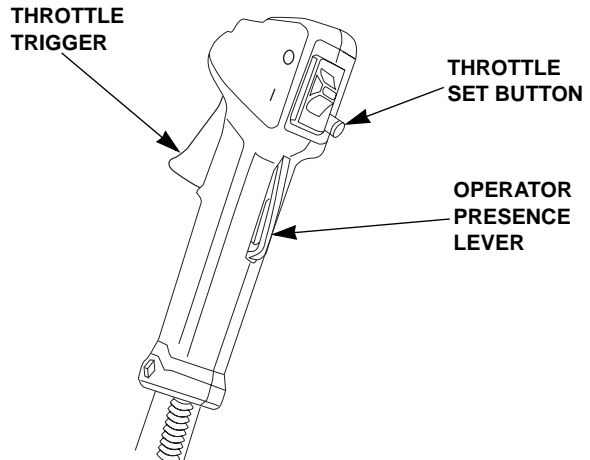

## Priming Bulb

Pressing the priming bulb pumps fuel from the fuel tank to the carburetor. This procedure is necessary for starting the engine.

To ensure fuel has reached the carburetor, press the priming bulb repeatedly until fuel can be seen in the clear plastic fuel return tube.

## Recoil Starter Grip

Pulling the starter grip operates the recoil starter to turn the engine for starting.

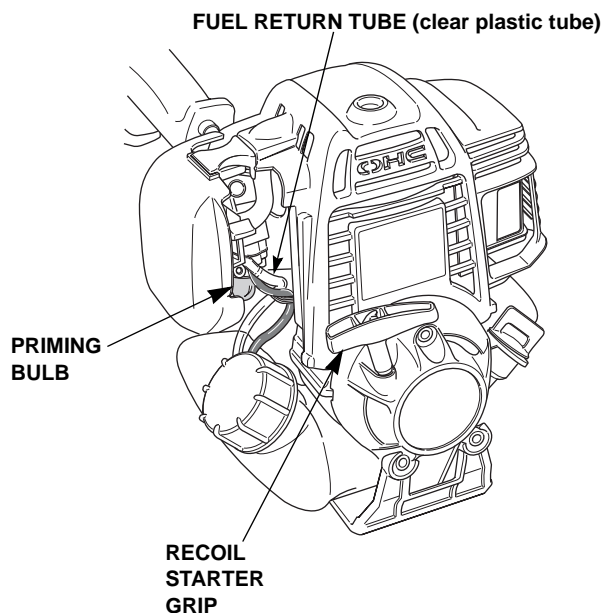

## EQUIPMENT

The Honda HHT25S and HHT35S trimmer/brush cutters are supplied with a shoulder harness and safety glasses. Refer to page 14 for a description of other equipment and protective clothing you will need.

### Shoulder Harness

A full shoulder harness must be worn by the operator of these Honda trimmers/brush cutters when equipped with a blade and debris shield. If the trimmer is equipped with a cutting-line head and shield with cutoff knife, the operator may wear a single-strap harness

A suitable shoulder harness is supplied with each new Honda HHT25S and HHT35S trimmer/brush cutter. Replacement shoulder harnesses may be purchased through any authorized Honda trimmer/brush cutter servicing dealer.

Before operation, adjust your shoulder harness as described on page 16.

### Quick-Release Latch

The shoulder harnesses supplied with these trimmers are equipped with a quick-release latch.

Pull the latch tab upward to detach the trimmer from the harness.

Insert the latch tongue in the slot of the quick-release latch to reattach the trimmer to the harness.

### Safety Glasses

Safety glasses or goggles that comply with ANSI (American National Standards Institute) standard Z87.1 must be worn by the operator of any Honda trimmer/brush cutter. The safety glasses supplied with each new Honda HHT25S and HHT35S trimmer/brush cutter comply with this ANSI standard.

FULL SHOULDER HARNESS (U-type handlebar)

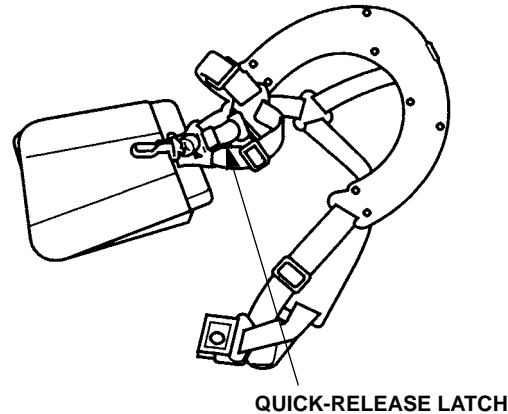

SINGLE-STRAP SHOULDER HARNESS (Loop type handle)

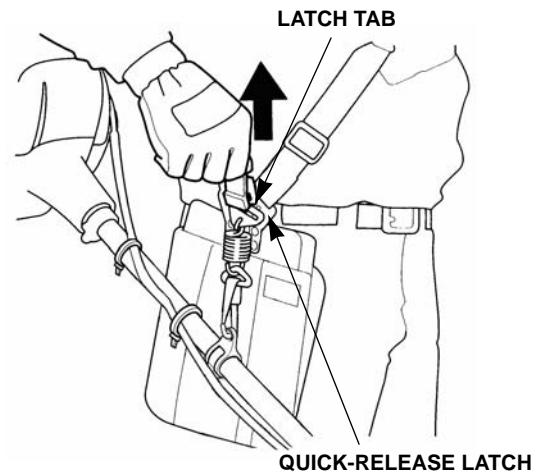
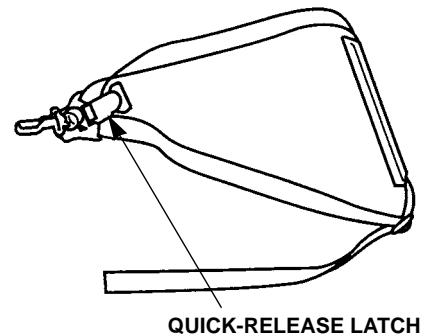

SAFETY GLASSES (ANSI Z87.1)

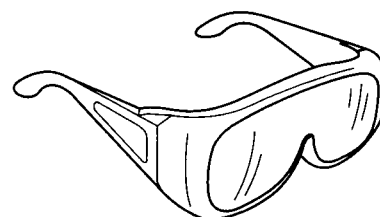

# BEFORE OPERATION

## ARE YOU READY TO OPERATE THE TRIMMER?

Your safety is your responsibility. A little time spent in preparation will significantly reduce your risk of injury.

### **Knowledge**

Read and understand this manual. Know what the controls do and how to operate them.

Familiarize yourself with the trimmer and its operation before you begin to use it. Know what to do in case of emergencies.

### **Physical and Mental Readiness**

You must be alert and in good physical condition to operate the trimmer. Do not operate the trimmer if you are tired, ill, or under the influence of alcohol, medication, or any substance that might impair your vision, dexterity, or judgment.

If you have any physical problem that may be aggravated by strenuous work, consult your physician before operating the trimmer.

### **Protective Clothing**

Wearing protective clothing will reduce your risk of injury. Do not wear loose clothing, jewelry, short pants, sandals, or go barefoot. Secure hair so it is above shoulder level.

### ***Eye, Face, and Head Protection***

Always wear safety glasses or goggles that comply with ANSI standard Z87.1 to protect your eyes from thrown objects. Prescription glasses may be worn under the safety glasses or goggles.

A helmet with a face shield is recommended for further protection. However, safety glasses or goggles should always be worn under the face shield. Do not rely on a face shield alone to protect your eyes.

Wearing a dust mask will help to reduce the amount of pollen and dust inhaled.

### ***Hearing Protection***

Hearing protectors will help to protect your ears from noise. Earmuff-style hearing protectors can also protect your ears from thrown objects.

### ***Hand and Body Protection***

Wear gloves, a long-sleeved shirt, and long pants made of heavy material. Clothing should fit closely but allow freedom of movement, and should have no strings, straps, etc. that could catch on brush or the trimmer. Keep clothing fastened.

### ***Foot Protection***

Wear sturdy work boots with good toe protection and nonslip soles.

## IS YOUR WORKING AREA READY?

Objects thrown by the trimmer can cause serious injury. Before operating the trimmer, carefully inspect the area and remove all objects that could be thrown by, or entangled in, the cutting attachment, such as rocks, broken glass, nails, wire, or string.

Clear the area of children, bystanders, and pets. Keep all children, bystanders, and pets at least 50 feet (15 meters) away from where the trimmer is being operated.

Even outside a 50-foot (15-meter) radius of the trimmer, there may be a risk of injury from thrown objects, so bystanders should be encouraged to wear eye protection.

If anyone approaches you while you are operating the trimmer, release the throttle trigger and stop the engine.



## IS YOUR TRIMMER READY TO GO?

For your safety, and to maximize the service life of your equipment, it is very important to take a few moments before you operate the trimmer to check its condition. Be sure to take care of any problem you find, or have your servicing dealer correct it, before you operate the trimmer.

### **WARNING**

Improperly maintaining this trimmer, or failing to correct a problem before operation, could cause a malfunction in which you could be seriously injured.

Always perform a preoperation inspection before each operation, and correct any problem.

### **Safety Inspection**

- Look around the engine for signs of oil or gasoline leaks. Wipe up any spills before starting the engine.
- Replace any damaged parts.
- Check that all fasteners are in place and secure. Tighten as necessary.

### **Cutting Attachment Inspection**

- Look for signs of damage to the cutting attachment (see pages 29 and 35). Replace any cutting attachment and parts that are worn out, bent, cracked, chipped, or damaged in any way.
- If using a metal blade, be sure it is sharp. A dull blade is more likely to snag and thrust.
- If using a metal blade on a trimmer equipped with a loop handle, be sure the barrier bar (optional part) is installed beneath the loop handle.
- Make sure the cutting attachment is properly installed and securely fastened (see pages 34 and 36).
- Check that the debris shield is the correct shield for the cutting attachment (see page 36), and that it is securely installed and in good condition.

### **Maintenance Inspection**

- Check the oil level (see page 26). Running the engine with a low oil level can cause engine damage.
- Check the air filter (see page 27). A dirty air filter will restrict air flow to the carburetor, reducing engine and trimmer performance.
- Check throttle cable free play (see page 28). The cable must be correctly adjusted and operate smoothly for good throttle control.
- Check the fuel level (see page 39). Starting with a full tank will help to eliminate or reduce operating interruptions for refueling.

# BEFORE OPERATION

## ARE YOUR SHOULDER HARNESS AND TRIMMER CORRECTLY ADJUSTED?

### Adjusting the Harness

Adjust the harness so the quick-release latch is at your right hip, as shown.

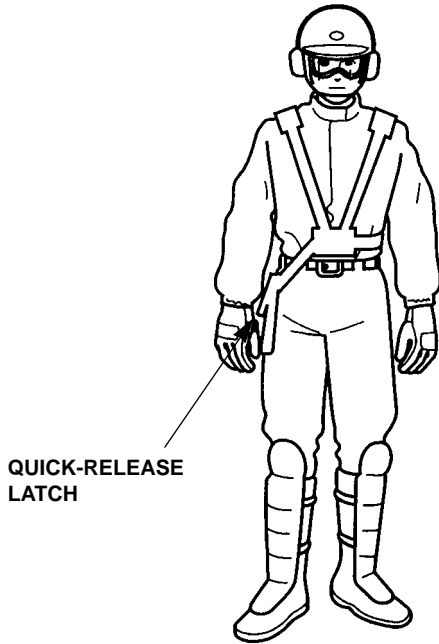

QUICK-RELEASE LATCH

FULL SHOULDER HARNESS

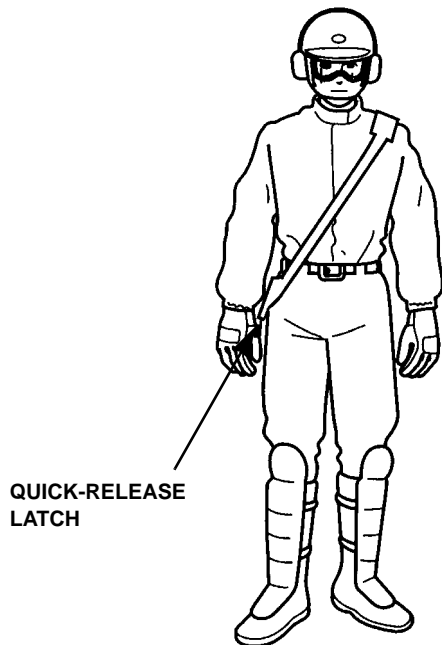

QUICK-RELEASE LATCH

SINGLE-STRAP SHOULDER HARNESS

### Balancing the Trimmer on the Shoulder Harness

Hang the trimmer on the harness hook, and see how it balances.

Adjust the shoulder harness, the harness hanger on the frame pipe, and the loop handle or U-type handlebar, so the handle or handlebars are in a comfortable operating position, and the trimmer hangs with its cutting attachment a few inches above the ground (see page 19).

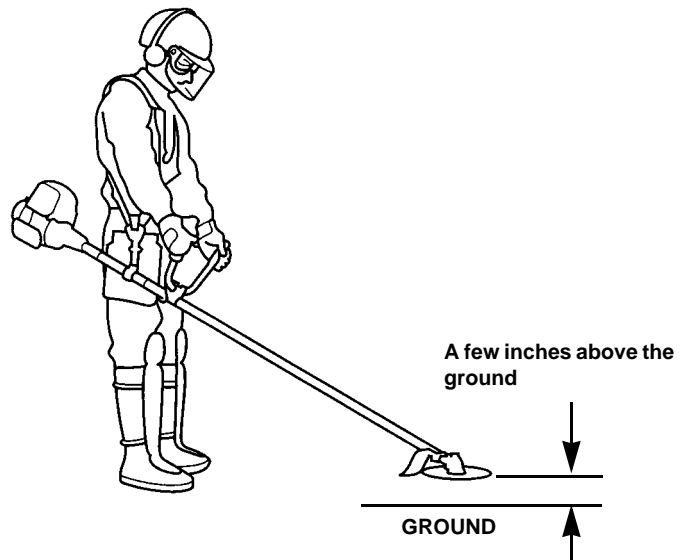

A few inches above the ground

GROUND

## SAFE OPERATING PRECAUTIONS

Before operating the trimmer for the first time, please review the *IMPORTANT SAFETY INFORMATION* chapter on page 4 and *BEFORE OPERATION* chapter starting on page 14.

Even if you have operated other trimmers, take time to become familiar with the operation of this trimmer's controls and handling.

For your safety, avoid starting or operating the engine in an enclosed area, such as a garage. Your engine's exhaust contains poisonous carbon monoxide gas which can collect rapidly in an enclosed area and cause illness or death.

If the trimmer starts to shake or vibrate, stop the engine immediately. After the cutting head has completely stopped, inspect it to determine the cause of the vibration. Sudden vibration is a sign of a hazardous problem, such as a loose or damaged blade. Do not operate the trimmer until the problem is corrected.

Prolonged exposure to vibration may cause vibration syndrome (Raynaud's disease). Symptoms include loss of skin color in the hands and numbness or a painful tingling sensation in the fingers, hands, and arms. Regular users of any power equipment may feel the numbness or pain spontaneously, at any time, not just after using the equipment. If any of these symptoms occur, see a physician immediately.

## STARTING THE ENGINE

1. To start a cold engine, move the choke lever to the CLOSED position.

To restart a warm engine, leave the choke lever in the OPEN position.

2. To start a cold engine, or after refueling an engine that has run out of fuel, press the priming bulb repeatedly until fuel can be seen in the clear plastic fuel return tube.

To restart a warm engine, it is not necessary to press the priming bulb.

3. Set the throttle trigger in the starting position, using the throttle set button.

To set the throttle trigger for starting, press the operator presence lever by gripping the control handle, pull the throttle trigger, then press and hold the throttle set button while releasing the throttle trigger.

4. Move the ignition switch to the ON (I) position.

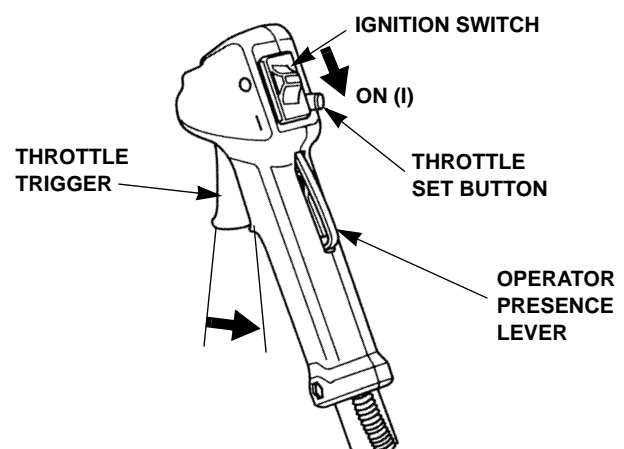
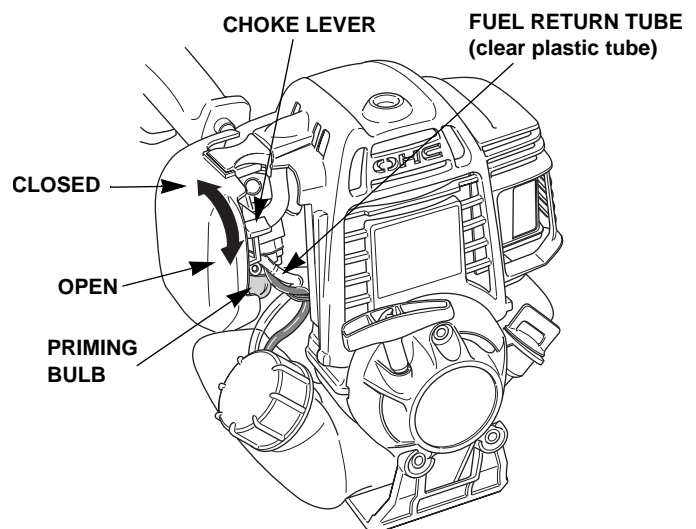

## OPERATION

---

5. Set the trimmer on the ground, resting on the debris shield and the fuel tank guard. Do not allow the cutting-line or blade to contact any obstruction.

Always rest the trimmer on the ground for starting, rather than holding it in the operating position. This prevents the end of the trimmer from swinging into something as you start the engine.

6. With your left hand, hold the frame pipe just ahead of the engine. With your right hand, pull the starter grip lightly until you feel resistance, then pull briskly. Return the starter grip gently.

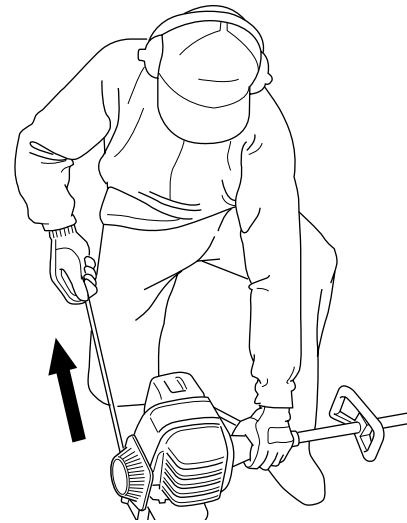

7. If the choke lever was moved to the CLOSED position to start the engine, gradually move it to the OPEN position as the engine warms up.

Allow the engine to warm up for a few minutes after a cold start. When the engine is warm enough to idle well, pull and release the throttle trigger to disengage the throttle set button.

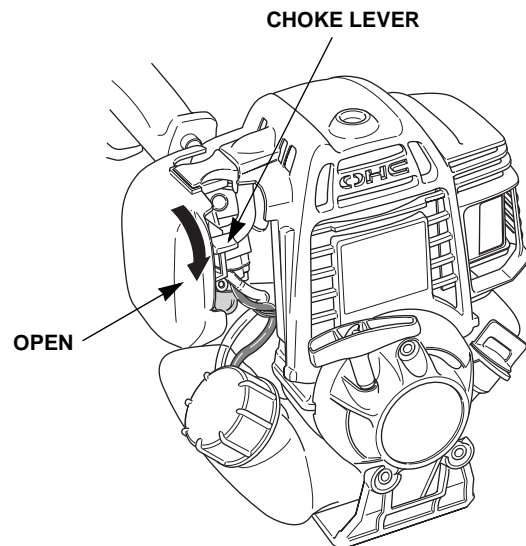

8. With the engine idling, hook the trimmer to your shoulder harness. Be careful to avoid contact with the cutting-line head or blade while handling the trimmer with the engine running.

The cutting-line head or blade should not rotate with the engine idling. If there is rotation at idle, adjust the idle speed correctly before using the trimmer. For idle adjustment, consult your authorized Honda servicing dealer.

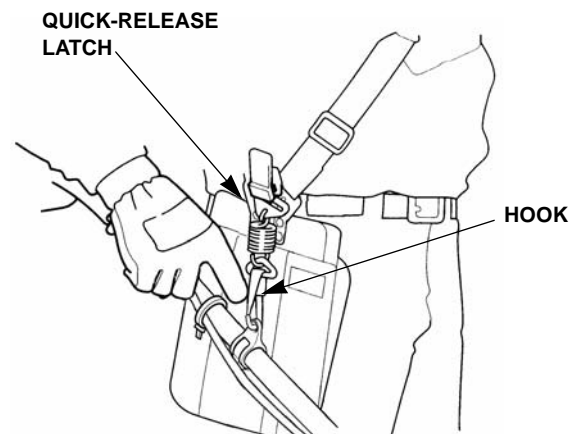

## STOPPING THE ENGINE

1. Release the throttle trigger.
2. Move the ignition switch to the STOP (O) position.

Wait for the cutting line head or blade to stop before allowing the end of the trimmer to contact anything.

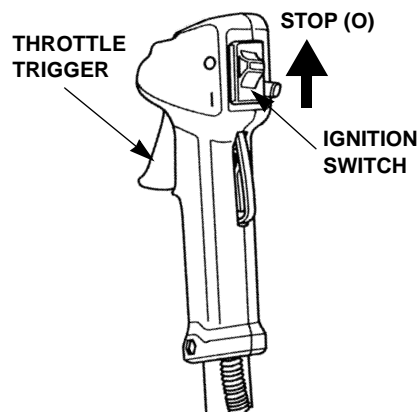

## **⚠ WARNING**

The blade will continue to spin briefly after the engine has stopped or the throttle trigger is released.

A coasting blade can cause injury.

Maintain proper control of the trimmer until the blade has completely stopped rotating.

## TRIMMER/HARNESS QUICK DISCONNECTION

To quickly detach the trimmer from the harness, pull the quick-release latch tab upward.

Insert the latch tongue in the slot of the quick-release latch to reattach the trimmer to the harness.

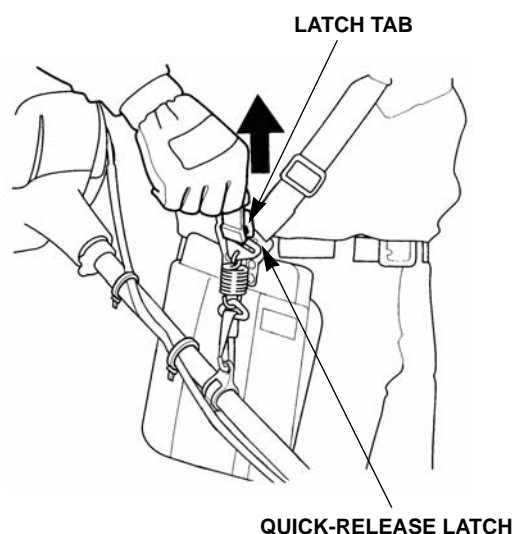

## TRIMMER OPERATION

### Operating Position

Hold the trimmer firmly with both hands, with your fingers and thumbs encircling the handles as shown. This will help you to keep the trimmer under control at all times.

- Keep firm footing and balance.
- Do not overreach.
- Keep the cutting attachment below waist level.
- Keep all parts of your body away from the rotating cutting attachment and hot surfaces.



# OPERATION

## Throttle Operation

Pull the throttle trigger toward the grip to increase engine speed and start the cutting attachment rotation.

The trimmer has the greatest cutting force at maximum engine speed.

Release the throttle trigger to reduce engine speed. At idle, the cutting attachment should coast to a stop.

## Using a Nylon Cutting-Line Head

As the ends of the line wear away, more line must be released from the cutting-line head. Your trimmer is factory-equipped with either a manual-feed or a semi-matic (bump feed) cutting-line head, which have different procedures for releasing line.

The debris shield is equipped with a cutoff knife that automatically removes any excess line that is released.

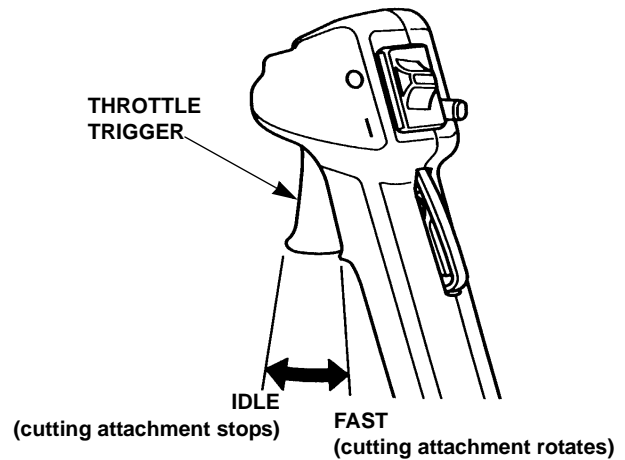

## Manual-Feed Cutting-Line Head

Line must be released with the cutting-line head stopped.

1. Stop the engine, and wait for the cutting-line head to coast to a complete stop.
2. Hold the housing, pull the spool out about a quarter of an inch, then turn the spool counterclockwise until it snaps into the housing again.

The spool will snap into the housing every sixth of a turn, which releases 1 to 1-1/2 inches of line.

MANUAL-FEED CUTTING-LINE HEAD

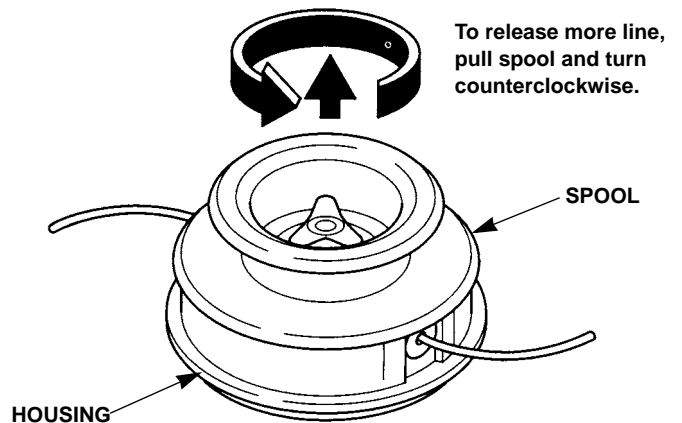

## Semi-Matic (bump-feed) Cutting-Line Head

Line must be released with the cutting-line head spinning rapidly.

With the engine running at full speed, tap the cutting-line head on hard, bare ground. Do not tap the cutting-line head on pavement or concrete.

Each tap releases about 2 inches of line.

SEMI-MATIC (bump-feed) CUTTING-LINE HEAD

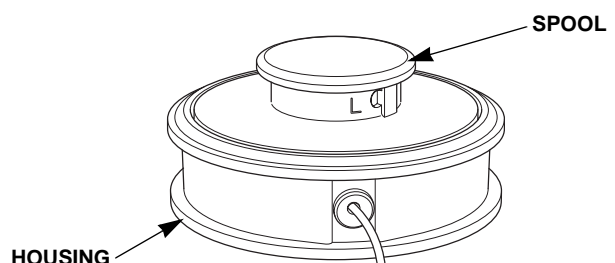

## Using Blades

Refer to the chart on page 9 for appropriate blade applications.

If using a blade on a Honda trimmer equipped with a loop handle, also install the optional Honda conversion kit that includes a full shoulder harness, a barrier bar, and a debris shield for blades. Follow the installation instructions and safety information that come with the kit.

Metal blades supplied with U-type handlebar models are supplied with a cover surrounding the edge of the blade. For your safety, and to protect the blade, the cover should be installed whenever the trimmer is not in use.

Be sure to remove the blade cover before starting the engine. Otherwise, the blade cover may fly off at high speed.

If the trimmer starts to vibrate after the blade strikes an object, stop the engine immediately and check the blade for damage. A damaged blade may break, and pieces of broken blade can become dangerous projectiles. Replace the blade if it is broken, cracked, bent, or damaged in any way.

## SAFE OPERATING PRACTICES

Be very careful when operating the trimmer over uneven or rough ground, and when the ground is wet and slippery. Watch out for hidden obstacles that could cause you to stumble. Operate the trimmer only under conditions with good visibility. Do not operate the trimmer where you cannot see what it is cutting.

### **⚠ WARNING**

Rotating cutting lines can cause serious abrasions and cuts, and blades can cut deeply.

- Keep away from the cutting lines or blade whenever the engine is running.
- Always stop the engine, and be sure the cutting line head or blade has stopped turning, before inspecting or handling the cutting lines or blade.

## Thrown Debris

The trimmer will throw debris in the direction of blade movement at the point of contact.

The cutting line head or blade rotates counterclockwise, as viewed from the operator's position. Tilting the cutting line head to the right will throw debris away from you, and tilting to the left will throw debris toward you.

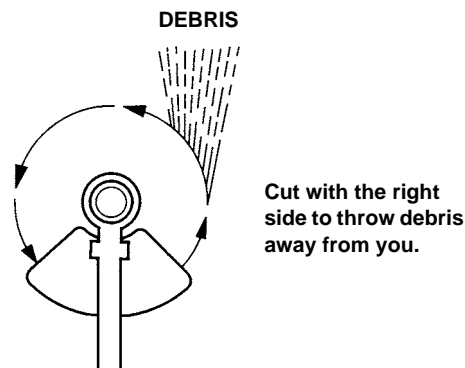

If the cutting line head or blade is held parallel to the ground, debris will scatter in all directions and there will be greater friction, which will wear out the cutting line or blade sooner.

When operating the trimmer near a hard surface such as a wall, work from an angle where debris that strikes the hard surface will ricochet away from you.

Gravel, loose stones, etc. can be picked up by the nylon cutting lines or blade and thrown many feet with enough force to cause serious personal injury and/or property damage. Before crossing graveled areas, release the throttle trigger to stop the cutting line head or blade.

# OPERATION

---

## Blade Thrust (Kickback)

Blade thrust (kickback) is the sudden, forceful, and uncontrolled movement of a blade-equipped trimmer that may occur if the blade binds while cutting or strikes a solid object.

Blade thrust (kickback) throws the trimmer in the direction opposite blade rotation at the point of contact, and the jolt received by the operator can result in further loss of control.

To reduce the risk of losing control, use metal blades on trimmers equipped with a U-type handlebar, or install the barrier bar (optional part) on trimmers equipped with a loop handle.

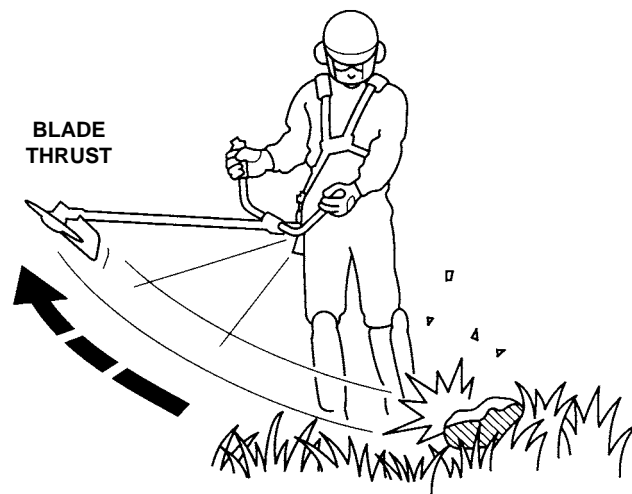

Replace or sharpen dull blades. Dull blades are more likely to bind in the cut and cause blade thrust.

Watch out for hidden obstacles such as rocks, stumps, roots, etc., that could cause the blade to kick back if struck. Blade thrust is more likely to occur in areas where it is difficult to see what is being cut.

Understand the reaction forces of the blade. When using a brush blade to saw through heavy brush and small saplings, saw with the side of the brush blade that is moving toward you and tends to pull the trimmer away from you.

Blades on Honda HHT25S and HHT35S trimmers rotate counterclockwise, as viewed from the operator's position. Therefore, the left side of the blade is moving toward you. With these trimmers, sawing with the left side of a brush blade will give you better control and less risk of kickback, though it will throw the sawdust toward you.

Cut from the side of saplings that will cause them to fall away from the trimmer. This will help prevent the blade from binding in the cut and kicking back.

Accelerate the engine to maximum speed before starting the cut, and saw through with uniform pressure.

## OPERATING TIPS

### Scything

Swing the trimmer in a level arc by rotating your body with a smooth, easy motion, rather than moving the trimmer with your arms. Do not chop at tough weeds and brush; let the cutting line or blade work through tough growths gradually.

To direct thrown debris away from you, tilt the cutting attachment to the right side, scythe from left to right, then return without cutting.

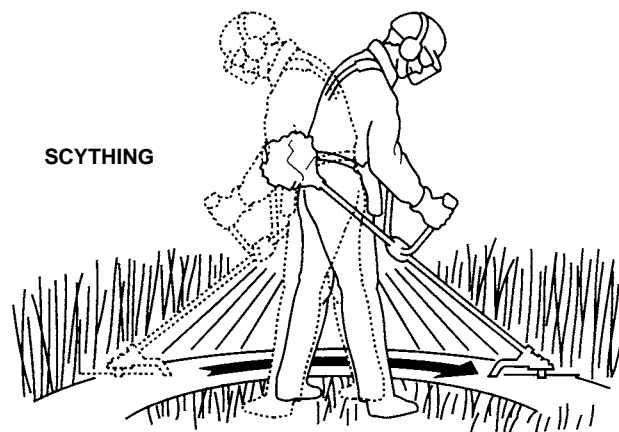



## Trimming and Edging

Use nylon line for cutting against a hard surface. Work from an angle where debris that strikes the hard surface will ricochet away from you.

Avoid contact with wires, wire fences, metal rods, etc. Overlapping a wire will cause the nylon line to wrap around the wire and break off.

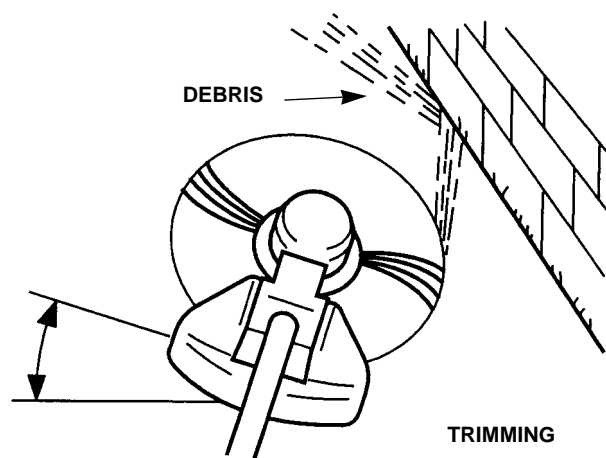

## Brush Clearing

Clearing brush with a brush blade may require both scything and sawing.

Scything with the right side of the blade will direct thrown debris away from you.

Be especially careful to direct debris away from you if recutting an area to shorten stumps. Short lengths of shrub and sapling stumps may tear off and be thrown at high speed.

Sawing heavy brush and saplings with the left side of the blade will reduce the risk of kickback.

Accelerate the engine to maximum speed before starting the cut, and saw through with uniform pressure.

If shrubs or saplings bind the blade, stop the engine, and while supporting the weight of the trimmer, push the shrub or sapling away to free the blade. Do not use the blade as a lever.



## Operation on Slopes

Start on the low side of a slope, and work upward. This will reduce your risk of slipping and falling, and it will give you a cutting angle that will better enable you to direct debris away from you.

Do not let the cutting line or blade dig into the slope, because that can cause stones and dirt to be thrown at you.

Do not raise the cutting attachment above waist level during operation, because that would increase the risk of thrown objects striking your face.

Avoid steep slopes that would require holding the cutting attachment above waist level. Avoid slippery slopes that might cause you to lose your balance.

# SERVICING YOUR TRIMMER

## THE IMPORTANCE OF MAINTENANCE

Good maintenance is essential for safe, economical, and trouble-free operation. It will also help reduce air pollution.

### **WARNING**

Improperly maintaining this trimmer, or failure to correct a problem before operation, can cause a malfunction in which you can be seriously hurt or killed.

Always follow the inspection and maintenance recommendations and schedules in this owner's manual.

To help you properly care for your trimmer, the following pages include a maintenance schedule, routine inspection procedures, and simple maintenance procedures using basic hand tools. Other service tasks that are more difficult, or require special tools, are best handled by professionals and are normally performed by a Honda technician or other qualified mechanic.

The maintenance schedule applies to normal operating conditions. If you operate your trimmer under severe conditions, such as sustained high-load or high-temperature operation, or use it in unusually wet or dusty conditions, consult your authorized Honda servicing dealer for recommendations applicable to your individual needs and use.

Remember that your authorized Honda servicing dealer knows your trimmer best and is fully equipped to maintain and repair it.

To ensure the best quality and reliability, use only new, genuine Honda parts or their equivalents for repair and replacement.

**Maintenance, replacement, or repair of the emission control devices and systems may be performed by any engine repair establishment or individual, using parts that are “certified” to EPA standards.**

## MAINTENANCE SAFETY

Some of the most important safety precautions follow. However, we cannot warn you of every conceivable hazard that can arise in performing maintenance. Only you can decide whether or not you should perform a given task.

### **WARNING**

Failure to properly follow maintenance instructions and precautions can cause you to be seriously hurt or killed.

Always follow the procedures and precautions in the owner's manual.

## Safety Precautions

- Make sure the engine is off before you begin any maintenance or repairs. This will eliminate several potential hazards:
  - **Carbon monoxide poisoning from engine exhaust.**  
Be sure there is adequate ventilation whenever you operate the engine.
  - **Burns from hot parts.**  
Let the engine and exhaust system cool before touching.
  - **Injury from moving parts.**  
Do not run the engine unless instructed to do so.
- Read the instructions before you begin, and make sure you have the tools and skills required.
- To reduce the possibility of fire or explosion, be careful when working around gasoline. Use only a nonflammable solvent, not gasoline, to clean parts. Keep cigarettes, sparks, and flames away from all fuel-related parts.

# SERVICING YOUR TRIMMER

## MAINTENANCE SCHEDULE

ITEM	Perform at every indicated interval.	REGULAR SERVICE PERIOD (1)						Refer to page
		Before each use	First month or 10 hrs	Every 3 months or 25 hrs	Every 6 months or 50 hrs	Every year or 100 hrs	Every 2 years or after each 300 hrs	
Engine oil	Check	O						26
	Change		O		O			
Air filter	Check	O						27
	Clean			O(2)				
Throttle cable	Check	O						28
Cutting attachment	Check	O						29 ~ 36
Debris shield	Check	O						29 ~ 36
Nuts, bolts, fasteners	Check (Retighten if necessary)	O						—
Shoulder harness quick-release	Check	O						19
Drive cable	Check-Lubricate				O(3)			—
Idle speed	Check-Adjust					O(3)		—
Valve clearance	Check-Adjust					O(3)		—
Spark plug	Check-Clean					O		37
	Replace						O	
Spark arrester	Check					O		38
Combustion chamber	Clean						O(3)	—
Gear case	Lubricate				O(3)			—
Clutch shoes and drum	Check				O(3)			—
Fuel filter	Check					O		40
Fuel tank	Clean					O		40
Fuel tubes	Check	Every two years [replace if necessary (3)]						—
Oil tube	Check	Every two years [replace if necessary (3)]						—
Engine cooling fins	Check				O			40

(1) Log hours of operation to determine proper maintenance intervals.

(2) Service more frequently when used in dusty areas.

(3) These items should be serviced by your servicing dealer, unless you have the proper tools and are mechanically proficient. Refer to the Honda shop manual for service procedures.

Failure to follow this maintenance schedule could result in non-warrantable failures.

# SERVICING YOUR TRIMMER

## ENGINE

### Engine Oil Level Check

Check the engine oil level before each use, or every 10 hours if operated continuously. Rest the trimmer on a level surface, with the engine stopped and in an upright position.

1. Remove the filler cap/dipstick and wipe it clean.
2. Insert and remove the dipstick without screwing it into the filler opening. Check the oil level shown on the dipstick.
3. If the oil level is low, fill to the edge of the oil filler hole with the recommended oil (see page 27). To avoid overfilling or underfilling, be sure the engine is in a level position, as shown.

#### **NOTICE**

*Running the engine with too little or too much oil can cause engine damage.*

4. Screw in the oil filler cap/dipstick securely.

### Engine Oil Change

Drain the used oil while the engine is warm. Warm oil drains quickly and completely.

1. Place a suitable container below the engine to catch the used oil, then remove the filler cap/dipstick and drain the used oil through the filler opening. Allow the used oil to drain completely.  
Please dispose of used motor oil in a manner that is compatible with the environment. We suggest you take used oil in a sealed container to your local recycling center or service station for reclamation. Do not throw it in the trash or pour it on the ground or down a drain.
2. With the engine in an upright position, fill to the edge of the oil filler hole with the recommended oil (see page 27).
3. Screw in the filler cap/dipstick securely.

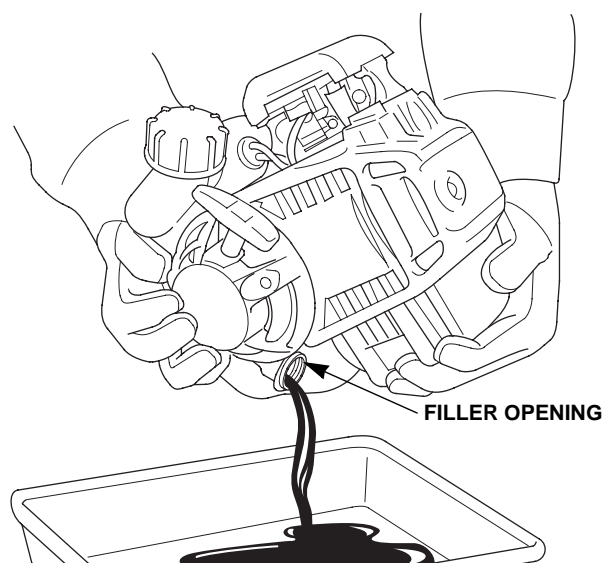
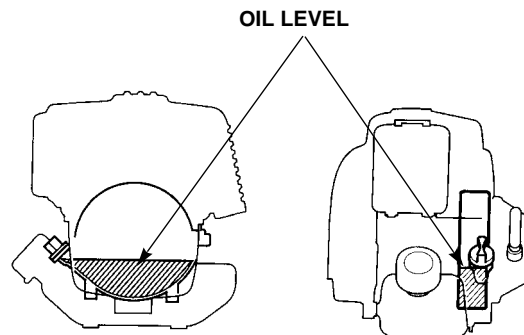
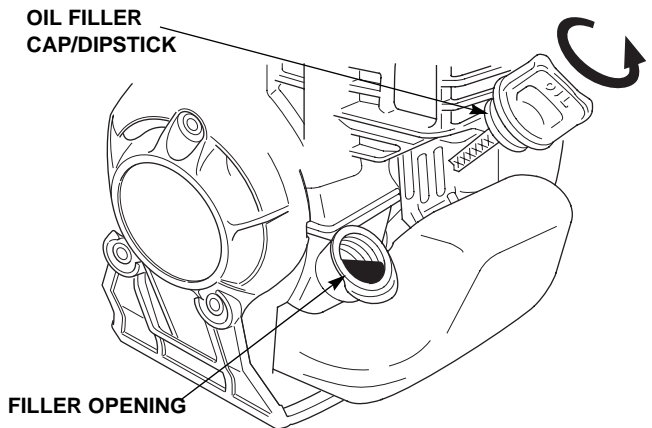

## Engine Oil Recommendations

Oil is a major factor affecting performance and service life. Use 4-stroke automotive detergent oil.

SAE 10W-30 is recommended for all temperatures within the recommended operating range for these trimmers. The recommended operating range extends from 23°F (-5°C) to 104°F (40°C).

The SAE oil viscosity and service classification are on the API label on the oil container. Honda recommends that you use API SERVICE category SJ or later.

## Air Filter Check

Squeeze the air cleaner latch tabs, and remove the air cleaner cover. Check the filter to be sure it is clean and in good condition.

If the filter is dirty, clean it as described under *Air Filter Cleaning*. Replace the filter if it is damaged. Reinstall the filter and air cleaner cover.

### **NOTICE**

*Operating the engine without an air filter, or with a damaged air filter, will allow dirt to enter the engine, causing rapid engine wear. This type of damage is not covered by the Distributor's Limited Warranty.*

## Air Filter Cleaning

A dirty air filter will restrict air flow to the carburetor, reducing engine performance. If you operate the engine in very dusty areas, clean the air filter more often than specified in the *MAINTENANCE SCHEDULE*.

1. Clean the air filter in warm soapy water, rinse, and allow to dry thoroughly. Or clean in non-flammable solvent and allow to dry.
2. Dip the air filter in clean engine oil, then squeeze out all excess oil. The engine will smoke when started if too much oil is left in the filter.
3. Wipe dirt from the air cleaner base and cover using a moist rag. Be careful to prevent dirt from entering the carburetor.

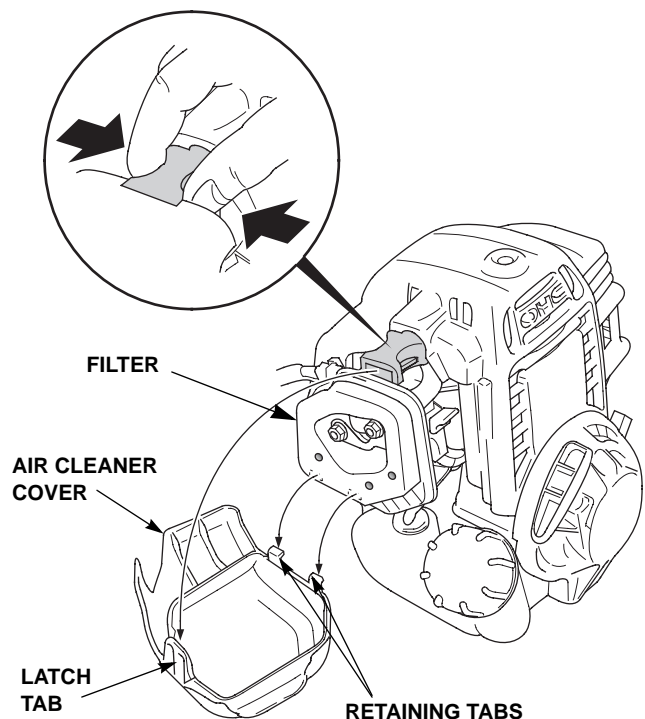

# SERVICING YOUR TRIMMER

## Throttle Cable Inspection

Verify the throttle trigger operates smoothly and the throttle cable is undamaged. If there is visible damage, or if the throttle trigger does not operate smoothly, have your authorized Honda servicing dealer replace the throttle cable.

Check the free play at the end of the throttle cable.

**Free play:** 1/16 ~ 1/8 in (1.0 ~ 3.0 mm)

If adjustment is needed, use the following cable adjustment procedure.

## Throttle Cable Adjustment

1. Loosen the lock nut with a 10 mm wrench, and turn the adjusting nut as required.
  - Turn the adjusting nut left for more free play.
  - Turn the adjusting nut right for less free play.
2. Tighten the lock nut and recheck cable free play.

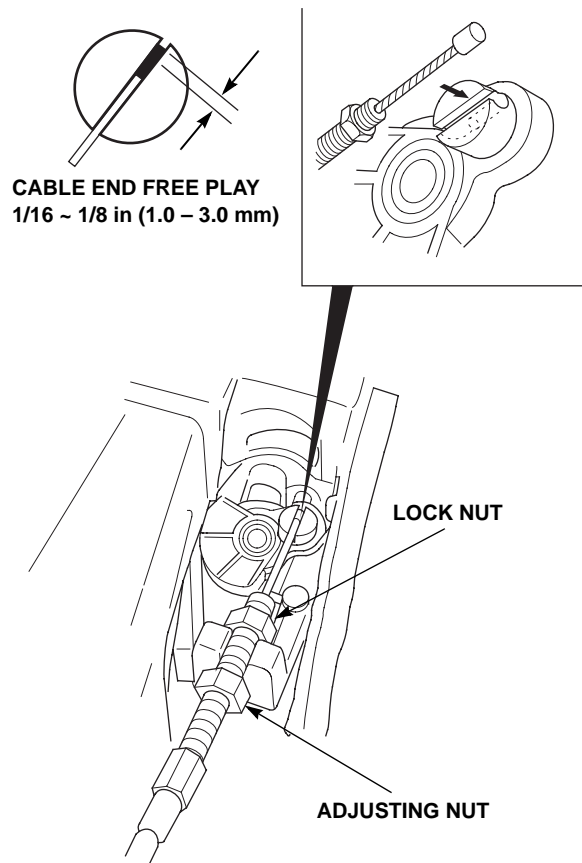

## CUTTING ATTACHMENTS

There are several cutting attachments for your trimmer. Use the following section to inspect, remove, service and install a standard (factory-installed) cutting attachment.

Always move the engine switch to the STOP (O) position and disconnect the spark plug cap before performing any inspection, adjustment, or maintenance on the trimmer.

### Cutting-Line Heads

All Honda trimmers come with either a manual or semi-matic cutting head. Read this section to learn how to inspect, install new line, and remove and install a cutting head from the trimmer.

#### Inspection

Make sure the nylon line is only sticking out of the metal eyelets on the head. If any of the line has come off the spool, follow the *Installing Replacement Nylon Line* instructions in this section to disassemble the spool and replace the line.

Examine the entire head area, including the debris shield, and clear or clean it free from dirt, debris, loose string, wire, or any other foreign materials.

For the manual feed head, make sure the three-sided knob is correctly tightened (page 31). For the semi-matic head, verify the spool is locked in place (page 33). For both head styles, check for any cracks in the plastic and replace any damaged parts.

### Installing Replacement Nylon Line

First, determine which cutting-line head style is on your trimmer. A manual-feed trimmer head has a three-sided knob on the bottom of the head, while the semi-matic head has a spring-loaded round button on the bottom of the head.

Do not use any kind of metal, wire, or wire rope line on the trimmer. Use only genuine Honda replacement nylon trimmer line or equivalent.

Honda trimmers come standard with low noise line. Using non-Honda line may result in increased noise levels.

For original, factory-installed Honda cutting-line heads, use only nylon monofilament line in the line sizes shown below.

	Line Size	
Model	0.095"	0.105"
HHT25S	OK	NO
HHT35S	OK	OK

See page 59 for replacement parts information.

# SERVICING YOUR TRIMMER

## Manual Cutting-Line Head

1. Clean any mud, dirt, debris, etc. from the area around the trimmer head; otherwise, it will be more difficult to service.
2. Rotate the left-hand threaded knob in the direction of the arrow and remove the knob.

Remove the spring and spool from the housing then remove any remaining old line from the spool.

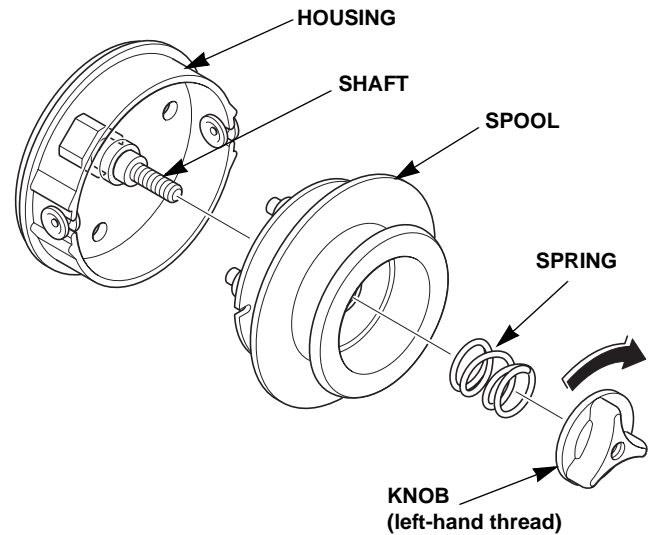

3. Measure approximately 20 feet (6 meters) of line, then thread one end through the hole in the ridge on the spool. Pull the line until the two line lengths are equal.

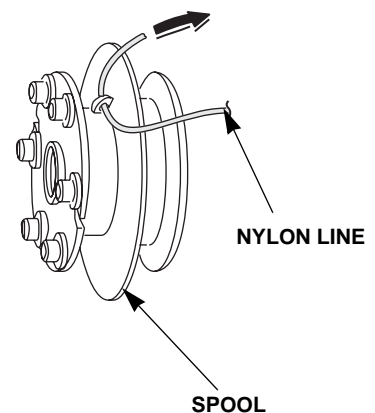

4. Wind both lines tightly and evenly from side-to-side ignoring the ridge. Feed the line while turning the spool in the direction of the arrow. Do not allow the lines to get twisted.

It is important to prevent the two lines from getting twisted over each other. Position a finger between the lines as you turn the spool to prevent the lines from twisting.

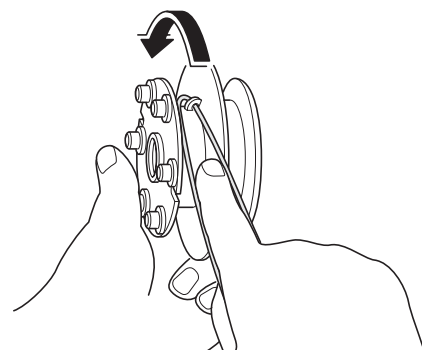



## SERVICING YOUR TRIMMER

5. When you have about 6 inches (150 mm) of line remaining, press the lines into the two notches on the bottom of the spool. This will hold the lines on the spool for reassembly.

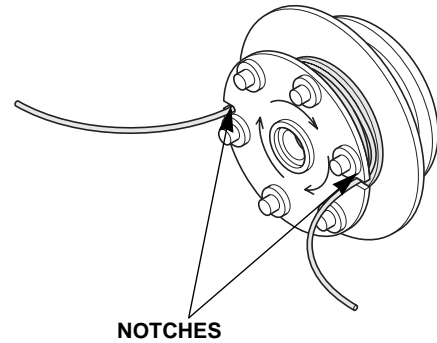

6. Feed both line ends through the metal eyelets in the housing.

Be careful not to let the line slip under the spool. When the spool reaches the bottom of the housing, the lines should snap out of the spool notches.

If you are not sure the lines have snapped out of the notches, gently pull the spool away from the housing about an 1/8 inch to inspect the lines. If necessary, gently pull each line until you hear it snap out of the notch. Trim the lines so they are equal length.

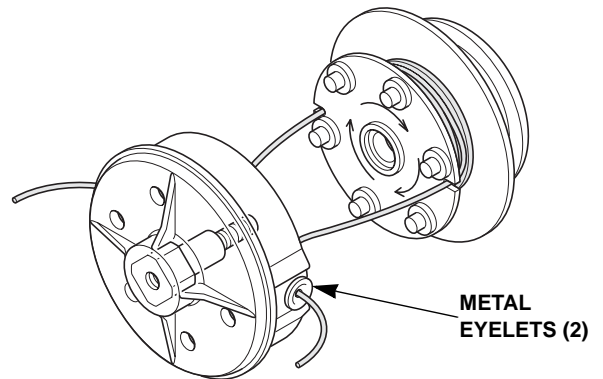

7. Install the spring and knob. Rotate the knob in the direction of the arrow and hand tighten securely.

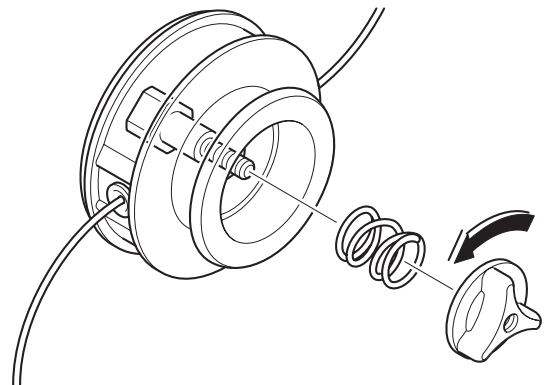

# SERVICING YOUR TRIMMER

## Semi-Matic (Bump-Feed) Cutting-Line Head

1. Clean any mud, dirt, debris, etc., from around the trimmer head area; otherwise, it will be more difficult to service.
2. Locate the half-round locking hole on the spool.

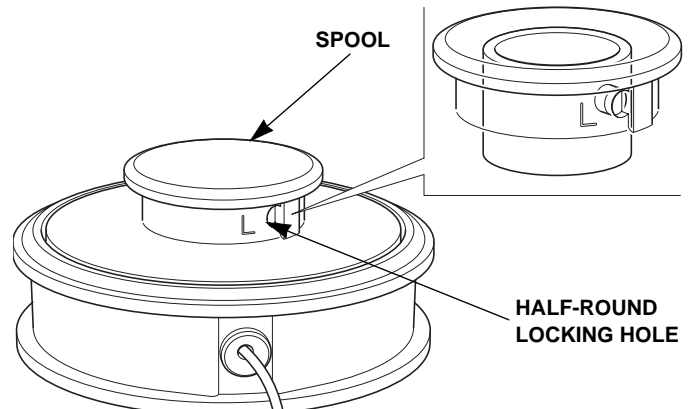

3. It may be necessary to lightly rotate the spool in the direction of the arrow about an 1/8 turn until the spool stops.

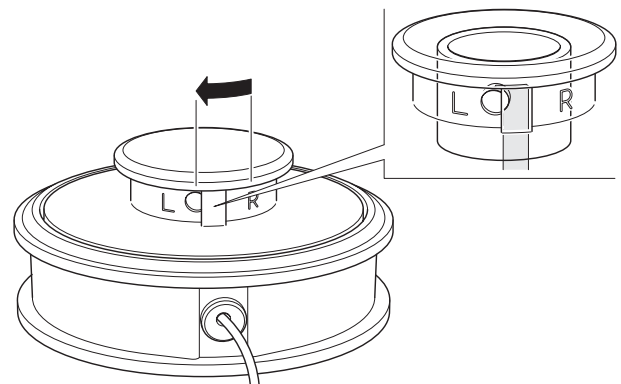

4. Hold the housing securely, then continue to rotate the spool in the direction of the arrow an additional 1/4 inch or the width of the channel to unlock the spool from the housing.

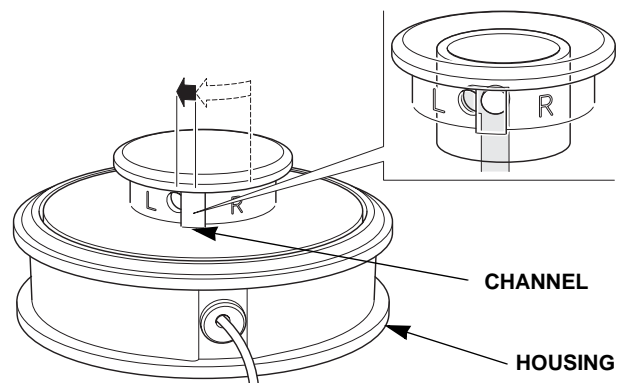

5. Lift the spool out of the housing and remove any remaining line from the spool.

6. Measure approximately 20 feet (6 meters) of new line, then thread one end through the hole in the ridge on the spool.

Pull the line until the two lengths are equal.

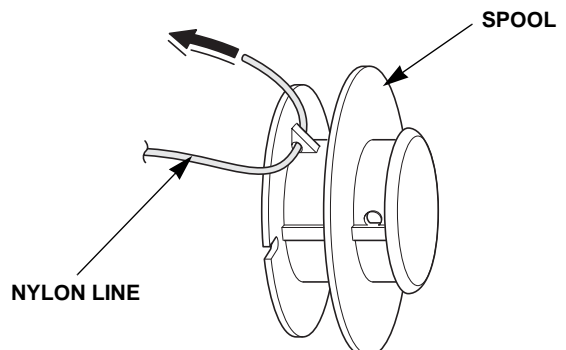

7. Wind both lines tightly and evenly from side to side ignoring the ridge. Feed the line while turning the spool in the direction of the arrow. Do not allow the line to get twisted.

It is important to prevent the two lines from getting twisting over each other. Position a finger between the lines as you turn the spool to prevent the lines from twisting.

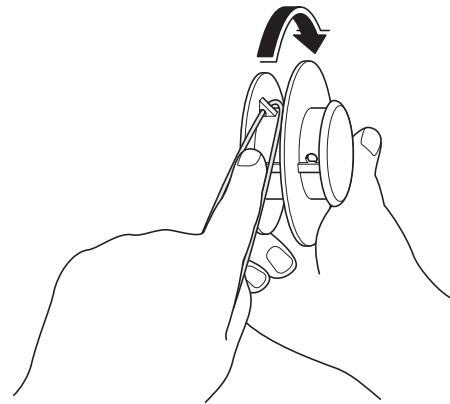

8. When you have about 6 inches (150 mm) of line remaining, press the lines into the two notches on the bottom of the spool. This will hold the lines on the spool for reassembly.

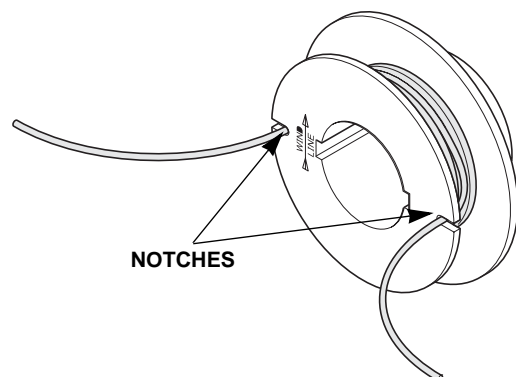

9. It may be necessary to push down and rotate the outer drive until the round lugs align with the metal eyelets.

Feed both line ends through the metal eyelets in the housing.

Align the channels in the spool with the round lugs on the outer drive. With the channels and notches aligned with the metal eyelets, slide the spool into the housing with a continuous snap-in motion. Be careful not to let the line slip under the spool. When the spool reaches the bottom of the housing, the lines should snap out of the spool notches.

If you are not sure if the lines have snapped out of the notches, gently pull the spool away from the housing about an 1/8 inch to inspect the lines. If necessary, gently pull each line until you hear it snap out of the notch.

10. Hold the housing and rotate the spool in the direction of the arrow to lock the round lug into the half-round locking hole. Trim the lines so they are equal length.

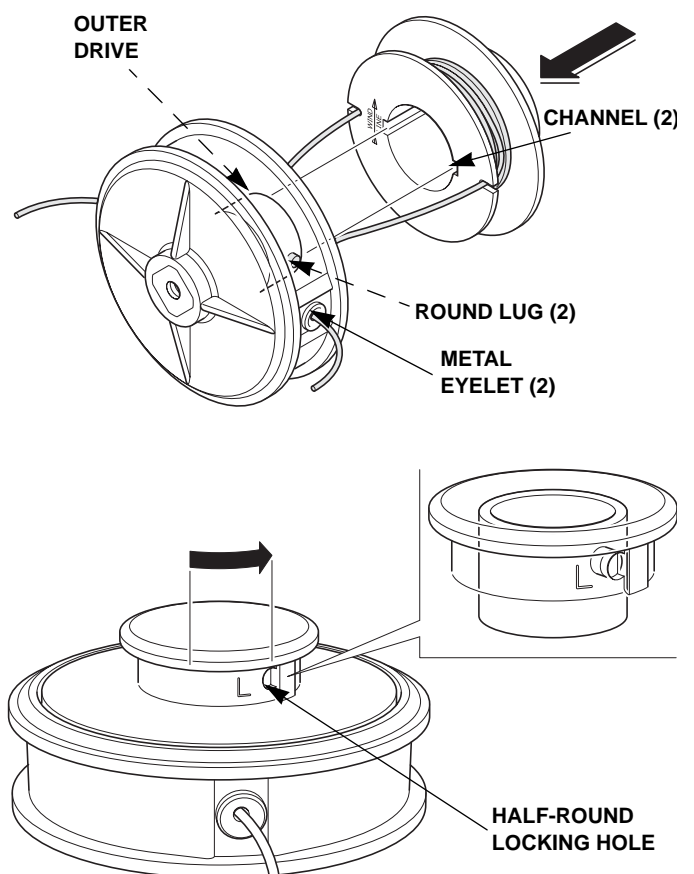

# SERVICING YOUR TRIMMER

## Removal and Installation

This section shows you how to remove and install either style trimmer head from your trimmer.

1. Insert the tip of a 4 mm hex wrench, or equivalent, fully into the gear case hole.
2. Turn the trimmer cutting-line head until you feel the tool drop into the hole in the cover plate/spacer A. Verify the trimmer head does not turn.
3. All output shafts use left-hand threads. Make sure the tool remains in the hole, then grasp the trimmer head and turn in the direction of the arrow to remove.
4. Remove spacer B and cover plate/spacer A from the output shaft. Note the order and orientation of each part as you remove them.
5. Installation is the reverse of removal. Always clean debris, dirt, loose line, etc. from the trimmer head and output shaft area before installation. Tighten the trimmer head securely.

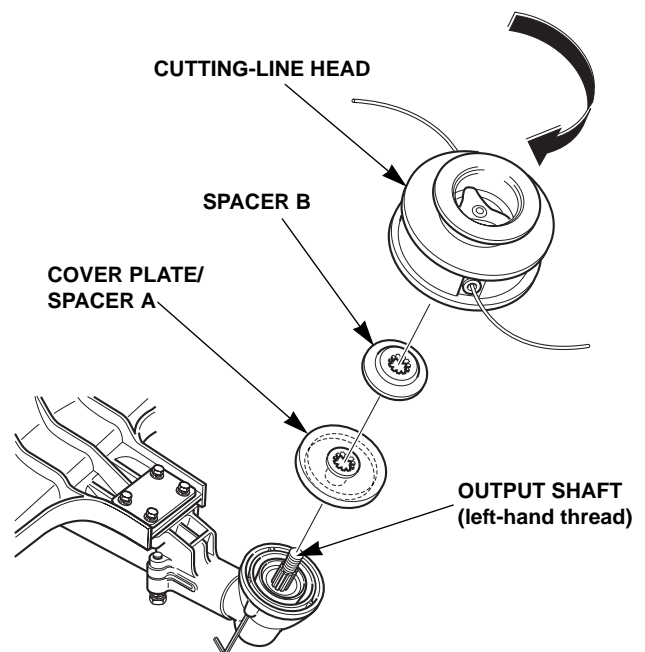
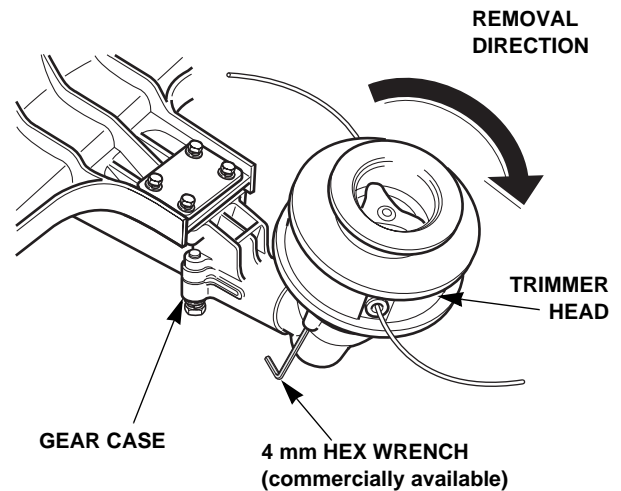

## Blade

### Blade Inspection

Always wear gloves when working around the blade. Before each use, check the blade for wear and damage, and check the tightness of the blade lock nut. Examine the entire head area, including the debris shield, and clear or clean it free from dirt, debris, loose string, wire, or any other foreign materials.

### ⚠ WARNING

A worn, damaged or cracked blade can break, and pieces of the damaged blade can become dangerous projectiles.

A dull blade is more likely to snag and thrust (kickback).

Inspect the blade regularly, and do not operate the trimmer with a dull, worn, or damaged blade.

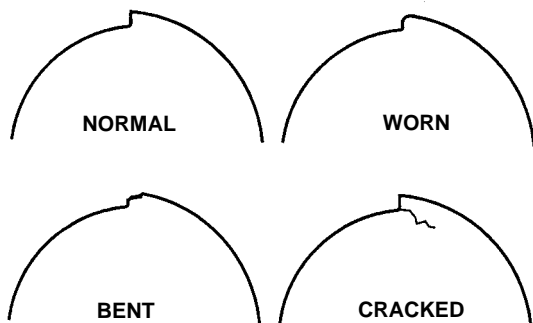

A dull blade can be sharpened, but a blade that is worn out, bent, cracked, chipped, or otherwise damaged must be replaced.

When a blade needs sharpening or replacement, take the trimmer to a Honda trimmer servicing dealer. Or, if you have a torque wrench, you can remove and install a blade yourself.

### Blade Removal and Installation

For loop handle models, a special optional **Barrier Kit** must be installed before a blade can be used. Refer to the instructions provided with each kit on how to install a blade on loop handle models.

Always wear gloves and install the blade cover on the blade when working around the blade.

A torque wrench is required to install the blade. If you do not have a torque wrench, have a Honda trimmer servicing dealer tighten the blade lock nut for you before using the trimmer.

If the blade lock nut is tightened too much, the output shaft can break. If the blade lock nut is not tightened enough, the blade could come off. In either case, it would be possible for the blade to fly off while you are operating the trimmer.

The blade lock nut is specially designed for this application. When replacing the lock nut, use only a genuine Honda replacement lock nut.

**BLADE SHARPENING:** To avoid weakening the blade or causing imbalance or poor cutting, the blade should be sharpened by trained staff at a Honda trimmer servicing dealer.

**BLADE REPLACEMENT:** Your Honda trimmer servicing dealer has cutting attachments that have been designed and approved for your trimmer and are covered by a warranty. Non-Honda attachments are usually designed for universal applications. Although aftermarket attachments may fit on your trimmer, they may not meet factory specifications and could make your trimmer unsafe.

# SERVICING YOUR TRIMMER

1. Install the protective plastic cover that came with the blade.
2. Insert a commercially available 4 mm hex tool or equivalent fully into the gear case hole.
3. Turn the blade until you feel the tool drop into the hole in cover plate/spacer A. Verify the blade does not turn. The output shaft and blade lock nut have a left-hand thread. Make sure the tool remains in the hole, then loosen the blade nut as shown. Pay attention to the order and orientation of the parts as they are removed.
4. Installation is the reverse of removal. Make sure you install the blade with the cutting edges in the direction of rotation. Be sure to align the hole in the blade with the shoulder on cover plate/spacer A. Tighten the blade nut to the specified torque.

**TORQUE:** 14 ft-lb (20 N · m, 2.0 kg-m)

## Changing the Debris Shield

Refer to the applicable illustration for removing and installing the debris shields. Tighten the spacer bolts/washers to the specified torque.

**TORQUE:** 2.5 ft-lb (3.4 N · m, 0.34 kg-m).

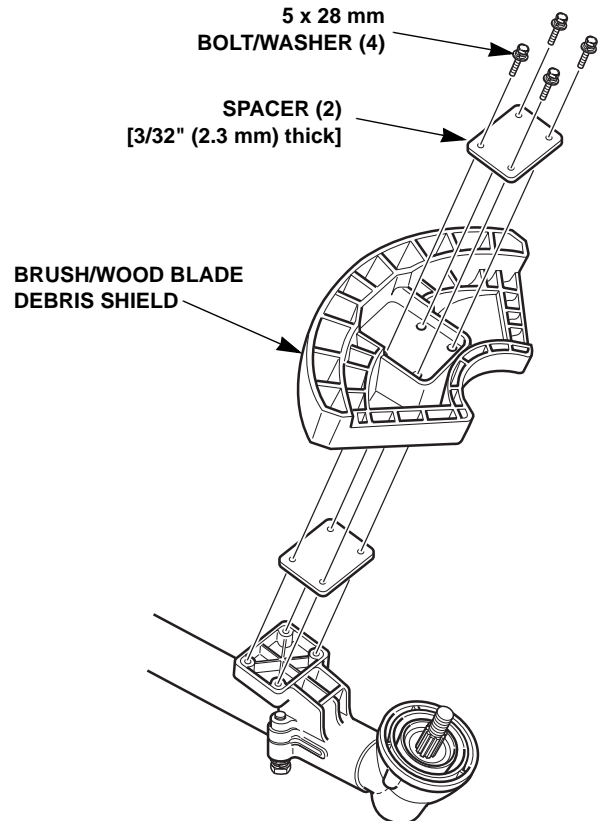
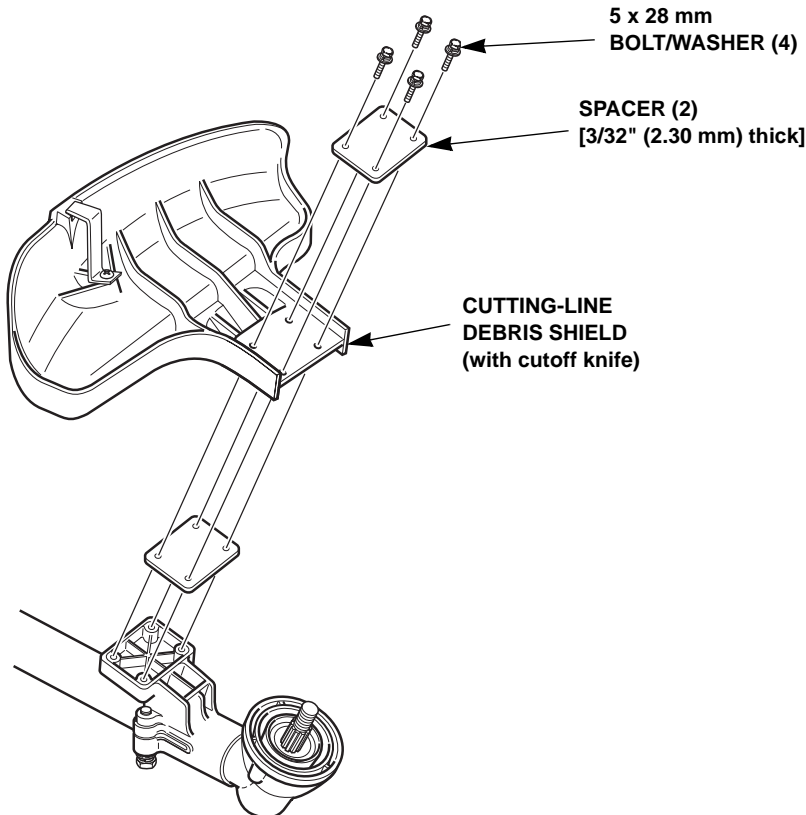
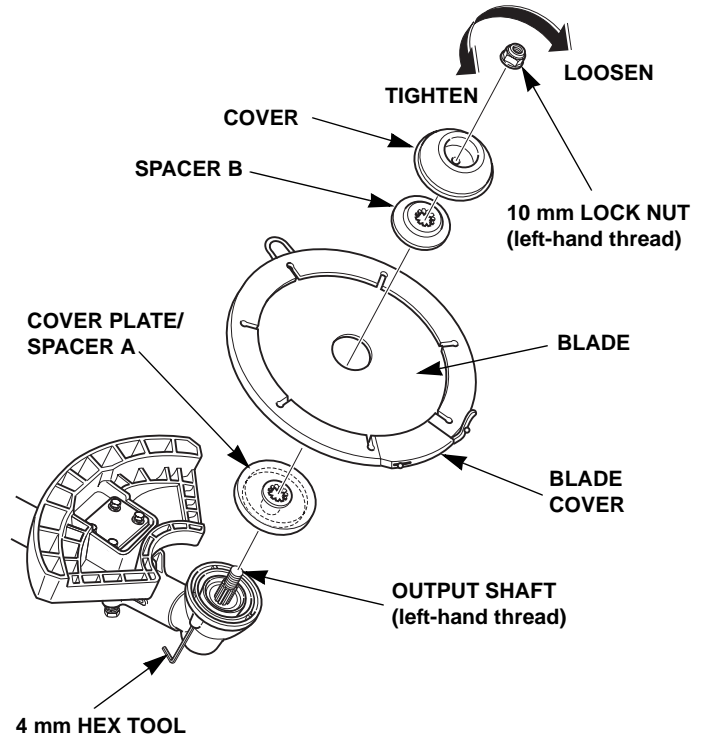

## Spark Plug Service

Recommended spark plug:  
CMR5HSB (NGK)

### NOTICE

*Incorrect spark plugs can cause engine damage.*

1. Remove the 5 x 12 mm hex bolt and top cover.
2. Disconnect the spark plug cap, and remove any dirt from around the spark plug area.
3. Remove the spark plug with a 5/8-inch spark plug wrench.
4. Inspect the spark plug. Replace it if the electrodes are worn, or if the insulator is cracked or chipped.
5. Measure the spark plug electrode gap with a suitable gauge. The gap should be 0.024 ~ 0.028 in (0.60 ~ 0.70 mm). Correct the gap, if necessary, by carefully bending the side electrode.
6. Install the spark plug carefully, by hand, to avoid cross-threading.
7. After the spark plug seats, tighten with a 5/8-inch spark plug wrench to compress the washer.

If reinstalling the used spark plug, tighten 1/8 ~ 1/4 turn after the spark plug seats.

If installing a new spark plug, tighten 1/2 turn after the spark plug seats.

### NOTICE

*A loose spark plug can overheat and damage the engine. Overtightening the spark plug can damage the threads in the cylinder head.*

8. Attach the spark plug cap.
9. Install the top cover and 5 x 12 mm hex bolt and tighten securely.

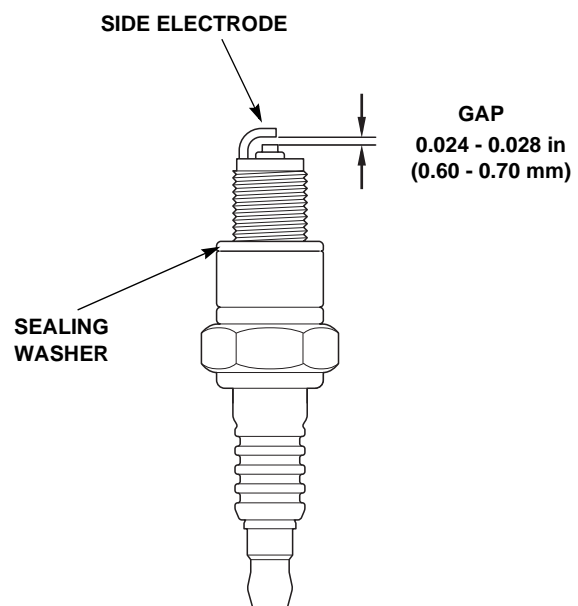
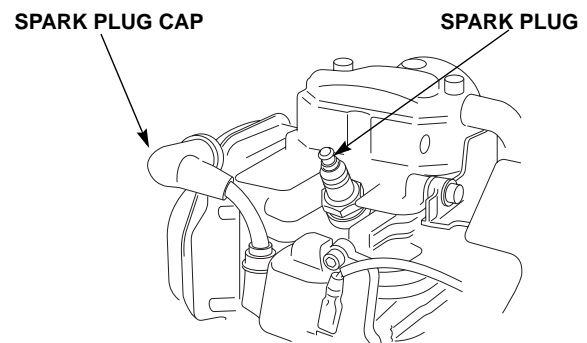
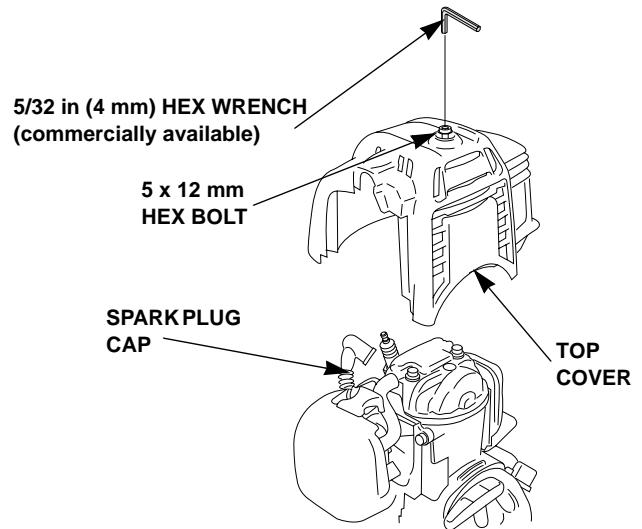

# SERVICING YOUR TRIMMER

## Spark Arrester Service

The spark arrester must be serviced every 100 hours to keep it functioning as designed.

If the engine has been running, the muffler will be very hot. Allow the muffler to cool before servicing the spark arrester.

1. Remove the 5 x 12 mm hex bolt and top cover
2. Remove the two 4 x 6 mm self-tapping screws from the spark arrester, and remove the spark arrester from the muffler.
3. Use a brush to remove carbon deposits from the spark arrester screen. Be careful to avoid damaging the screen.

The spark arrester must be free of breaks and holes. Replace the spark arrester if it is damaged.

4. Install the spark arrester, top cover, and 5 x 12 mm hex bolt and tighten securely.

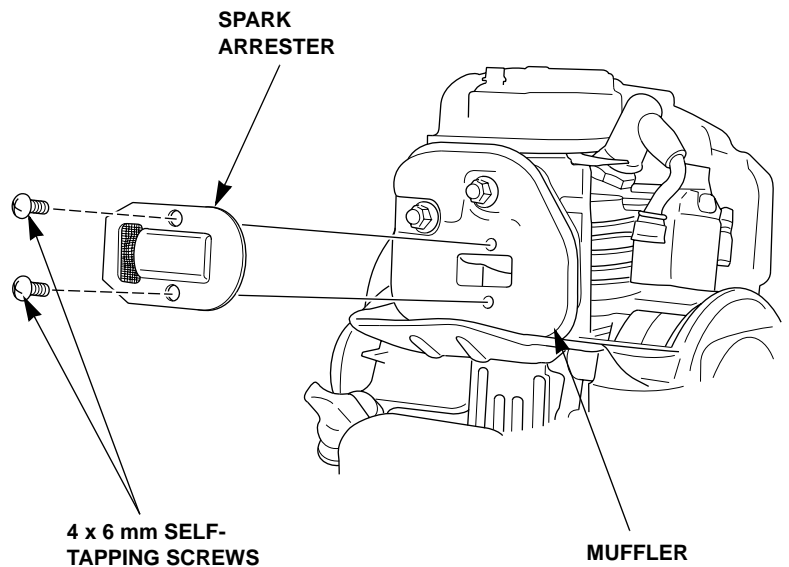
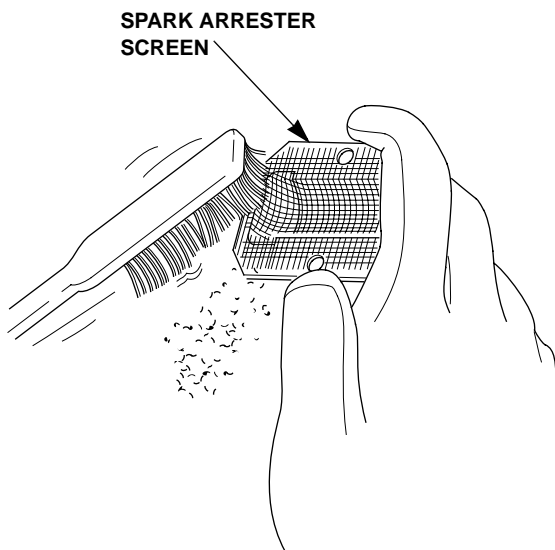
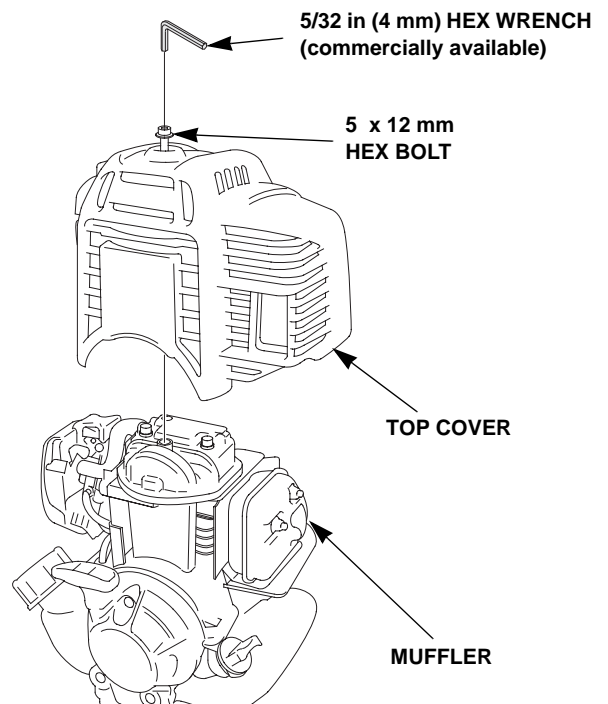



## FUEL SYSTEM

### Refueling

#### Fuel tank capacities:

**HHT25S:** 0.13 US gal/16.9 fl oz (0.50 ℓ)

**HHT35S:** 0.17 US gal/22.0 fl oz (0.65 ℓ)

Check the fuel level by looking through the translucent fuel tank. If the fuel level is low, refuel in a well-ventilated area with the engine stopped. If the engine has been running, allow it to cool first.

To refuel, rest the trimmer on the ground with the fuel tank cap facing up, as shown. Remove the fuel tank cap and fill the tank with gasoline to the bottom of the filler neck. Refuel carefully to avoid spilling fuel. Do not overfill. There should be no fuel in the filler neck. After refueling, tighten the fuel tank cap securely.

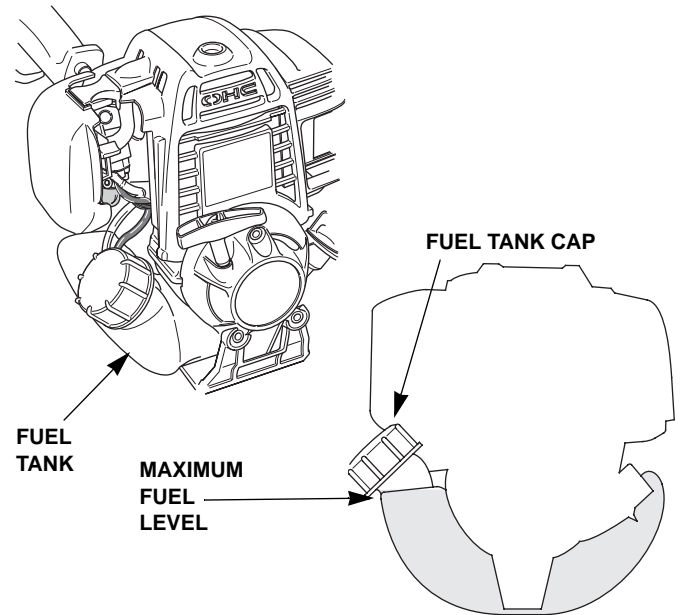

### Fuel Recommendations

**Use unleaded gasoline with a pump octane rating of 86 or higher.**

These engines are certified to operate on unleaded gasoline. Unleaded gasoline produces fewer engine and spark plug deposits and extends exhaust system life.

Never use stale or contaminated gasoline or an oil/gasoline mixture. Avoid getting dirt or water in the fuel tank.

You may occasionally hear a light “spark knock” or “pinging” (metallic rapping noise) while operating under heavy loads. This is no cause for concern.

If spark knock or pinging occurs at a steady engine speed, under normal load, change brands of gasoline. If spark knock or pinging persists, see an authorized Honda servicing dealer.

### **NOTICE**

*Running the engine with persistent spark knock or pinging can cause engine damage.*

Running the engine with persistent spark knock or pinging is misuse, and the *Distributor's Limited Warranty* does not cover parts damaged by misuse.

### **⚠ WARNING**

Gasoline is highly flammable and explosive.

You can be burned or seriously injured when handling fuel.

- Stop the engine and keep heat, sparks, and flame away.
- Handle fuel only outdoors.
- Wipe up spills immediately.

Never refuel the engine inside a building where gasoline fumes may reach flames or sparks. Keep gasoline away from appliance pilot lights, barbecues, electric appliances, power tools, etc.

Spilled fuel is not only a fire hazard, it causes environmental damage. Wipe up spills immediately.

Move at least 10 feet (3 meters) away from the fueling source and site before starting the engine.

### **NOTICE**

*Fuel can damage paint and plastic. Be careful not to spill fuel when filling your fuel tank. Damage caused by spilled fuel is not covered under warranty.*

# SERVICING YOUR TRIMMER

---

## Fuel Filter and Fuel Tank Cleaning

1. Remove the fuel tank cap and empty the fuel tank into an approved gasoline container. Use a funnel to avoid spilling gasoline.
2. Pull the fuel filter out through the fuel filler neck by hooking the black fuel supply tube with a piece of wire, such as a partly straightened paper clip.
3. Inspect the fuel filter. If the fuel filter is dirty, remove it and wash it with nonflammable solvent. Be careful to avoid damaging the filter.

Replace the filter if it is damaged or excessively dirty.

4. Rinse sediment from the fuel tank with nonflammable solvent.
5. Insert the fuel filter in the fuel tank and install the fuel tank cap.

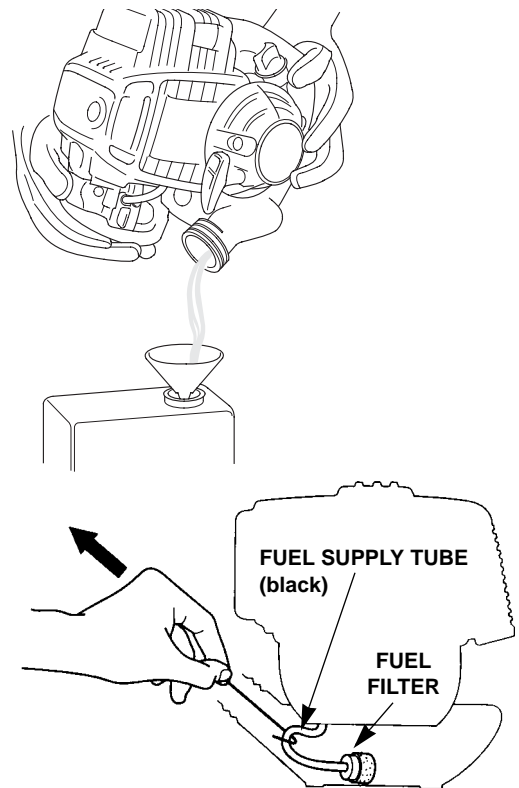

## Cooling Fin Inspection

Remove the 5 x 12 mm hex bolt and top cover. Inspect the engine cooling fins and clean out any dirt and debris.

Install the top cover and 5 x 12 mm hex bolt, then tighten securely.

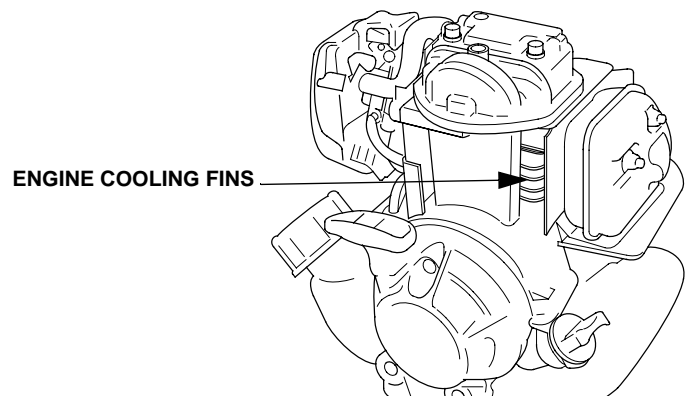

After assembly and before operation, review the Safe Operating Precautions on page 17.

## IMPORTANCE OF PROPER ASSEMBLY

Proper assembly is essential to operator safety and the reliability of the machine. Any error or oversight made by the person assembling and servicing a machine can result in faulty operation, damage to the machine, or injury to the operator.

Some of the most important safety precautions are given below. However, we cannot warn you of every conceivable hazard that can arise in performing this assembly. Only you can decide whether or not you should perform a given task.

### **WARNING**

Improper assembly can cause an unsafe condition that can lead to serious injury or death.

Follow the procedures and precautions in the assembly instructions carefully.

### **WARNING**

Failure to properly follow instructions and precautions can cause you to be seriously hurt or killed.

Follow the procedures and precautions in this manual carefully.

## IMPORTANT SAFETY PRECAUTIONS

- Make sure you have a clear understanding of all basic shop safety practices and that you are wearing appropriate clothing and safety equipment.
- Read the instructions before you begin and be sure you have the tools and skills required to perform the tasks safely.
- Make sure the engine is off before you begin any maintenance or repairs. This will help eliminate several potential hazards:
  - Carbon monoxide poisoning from engine exhaust. Be sure there is adequate ventilation whenever you run the engine.
  - Burns from hot parts. Let the engine and exhaust system cool before touching.
  - Injury from moving parts. Do not run the engine unless the instruction tells you to do so. Even then, keep your hands, fingers, and clothing away from moving parts. Do not run the engine when any protective guard or shield is removed.
- To reduce the possibility of a fire or explosion, be careful when working around gasoline or batteries. Use only a nonflammable solvent, not gasoline, to clean parts. Keep all cigarettes, sparks, and flames away from all fuel-related parts.

# ASSEMBLY

## UNPACKING

Carefully remove the trimmer and loose parts from the carton and compare the loose parts with the inventory list below.

### Tools Required (U-type handlebar only):

A 4 mm hex wrench, 8 and 17 mm sockets, 0 to 25 ft-lb torque wrench.

## LOOSE PARTS

Check all loose parts against the following list. Contact your authorized Honda servicing dealer if any of the loose parts shown are not included with your trimmer.

Ref. No	Description	All	Loop handle	U-type handlebar	Qty.
1	Owner's Manual	•			1
2	Goggles	•			1
3	Oil bottle	•			1
4	Single-strap shoulder harness		•		1
5	Full shoulder harness			•	1
6	Debris shield, for 30 ~ 80 tooth saw blades only			•	1
7	Cover			•	1
8	Left-hand thread lock nut, 10 mm			•	1
9	Saw blade, 50 tooth/10 in			•	1
10	Blade cover			•	1

1

2

3

4

**U-TYPE HANDLEBAR**

5

6

7

8

9

10

## TRIMMER ASSEMBLY

### U-Shaped Handlebar Installation

1. Remove the four 5 x 28 mm bolt/washers and handlebar holder A.
2. Set the U-shaped handle into handlebar holder B with the throttle trigger facing to the right.

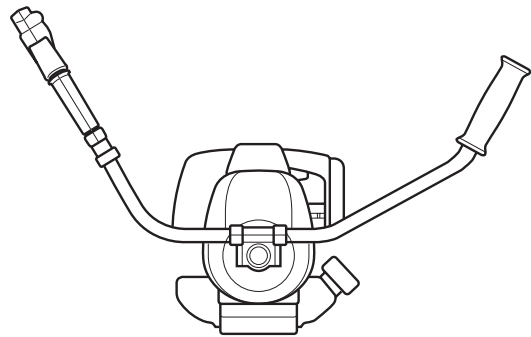
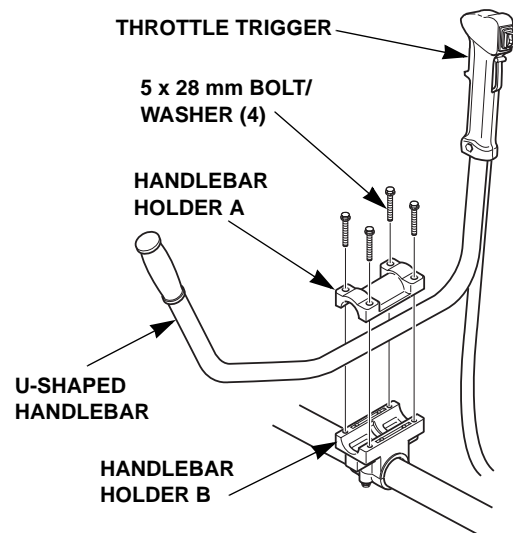

3. Adjust the handlebar position as shown.

4. Tighten the four 5 x 28 mm bolt/washers.  
**TORQUE:** 3.6 ft-lb (5 N·m, 0.5 kg-m)

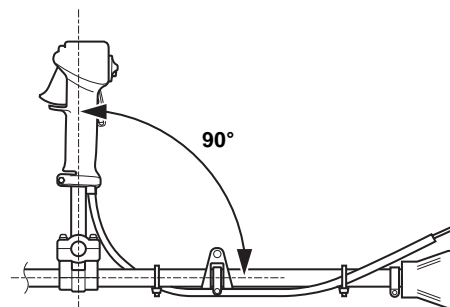

5. Make sure the tie straps are positioned as shown.

6. Operate the throttle trigger and make sure the throttle operates smoothly.

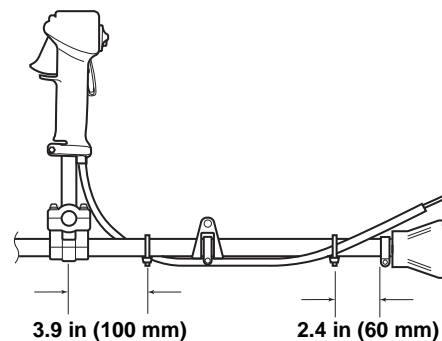

# ASSEMBLY

## Saw Blade

The U-type handlebar models are shipped with a manual nylon cutting-line head installed on the trimmer. If the saw blade is needed, move the ignition switch to the STOP (O) position and disconnect the spark plug cap from the spark plug. Wear protective gloves when working around the cutting-line head and saw blade.

### Cutting-Line Head Removal

1. Align the gear case hole with the groove in cover plate/spacer A. Insert a 4 mm hex wrench or equivalent into the gear case hole to prevent the left-hand threaded output shaft from turning.
2. Hold the wrench and rotate the cutting-line head in the direction of the arrow and remove the cutting-line head assembly.

Remove the cutting-line head as an assembly. Do not remove the knob. Refer to page 31 for a cutting-line head assembly drawing.

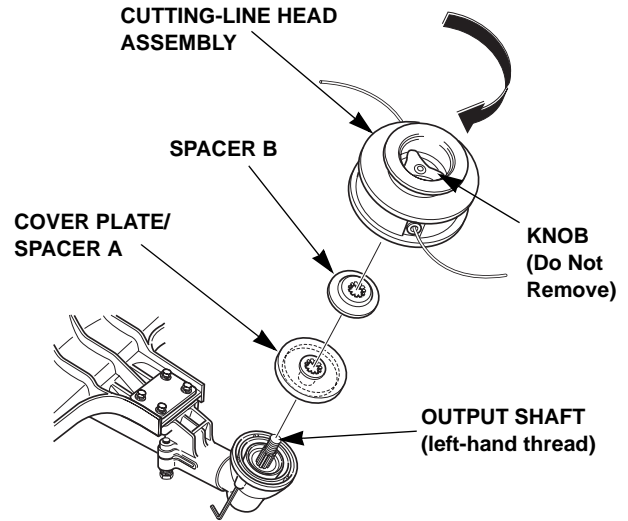

### Debris Shield Removal/Installation

Remove the cutting-line debris shield and install the brush/wood blade debris shield.

Tighten the bolt/washers:

**TORQUE:** 2.5 ft-lb (3.4 N·m, 0.34 kg-m)

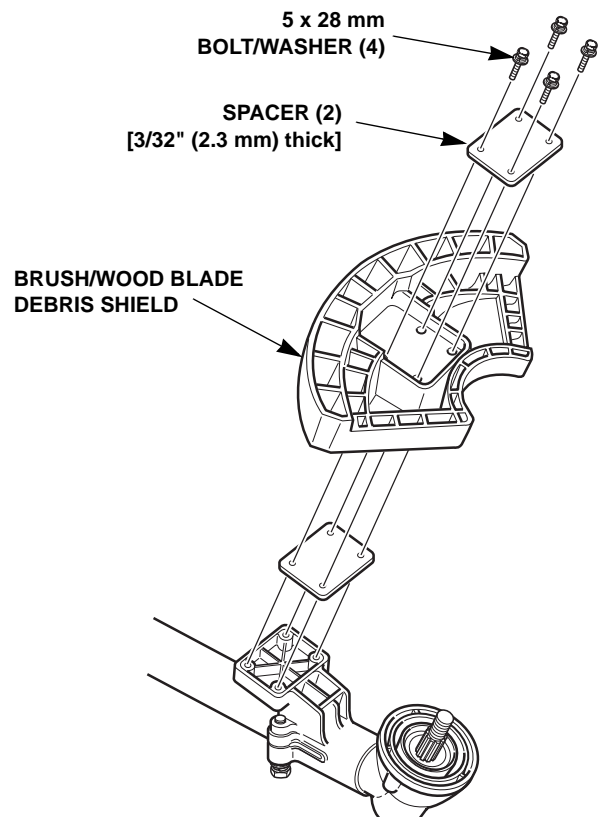
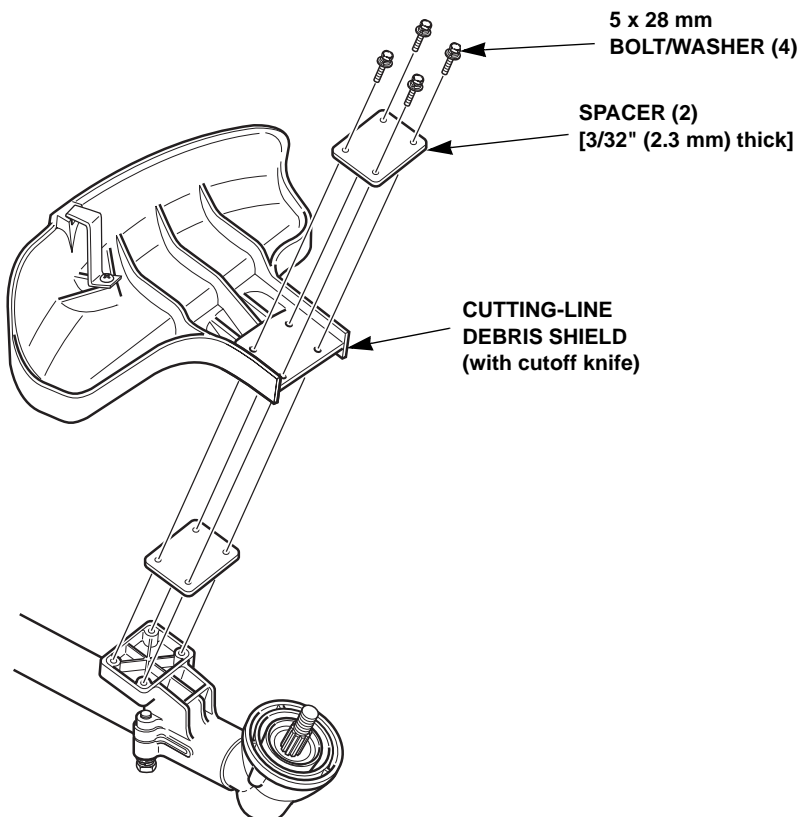

## Saw Blade Installation

1. Insert a 4 mm hex wrench or equivalent into the gear case hole to prevent the output shaft from turning.
2. Install cover plate/spacer A onto the output shaft as shown.
3. With the blade cover installed on the blade, install the blade by aligning the center of the blade with the shoulder on cover plate/ spacer A.
4. Install spacer B, the cover, and the 10 mm lock nut as shown.

Be sure to install the blade with the cutting edges of the saw teeth in the direction of rotation; the side with the white markings must face the debris shield.

The output shaft has left-hand threads. Tighten the 10 mm lock nut counterclockwise.

**TORQUE:** 14 ft-lb (20 N•m, 2.0 kg-m)

5. Remove the 4 mm hex wrench or equivalent from the gear case.

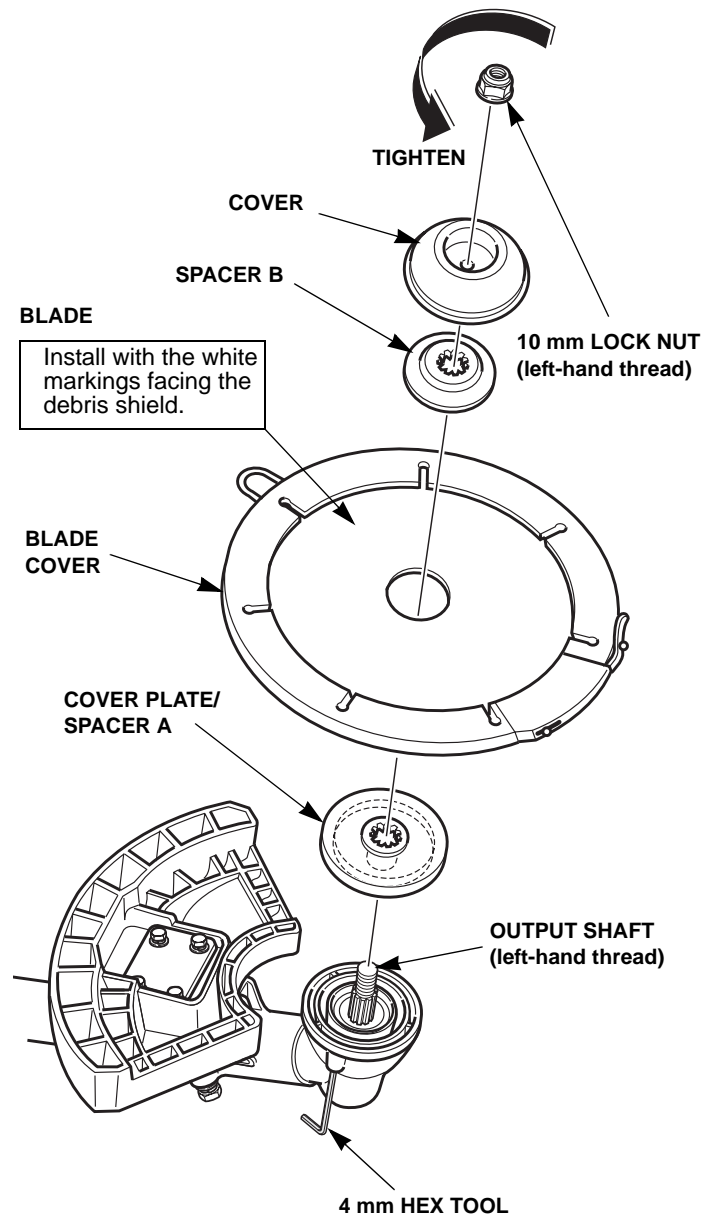

# ASSEMBLY

## BLADE COVER REMOVAL

1. Turn the blade cover slowly until the cover latch is clear of the debris shield.

Unfasten the latch by lifting the tab off the post.

2. Pull the post end away from the blade and set it on top of the blade as shown.

3. Turn the blade cover slowly until the post end is clear of the debris shield, then remove the blade cover from the blade.

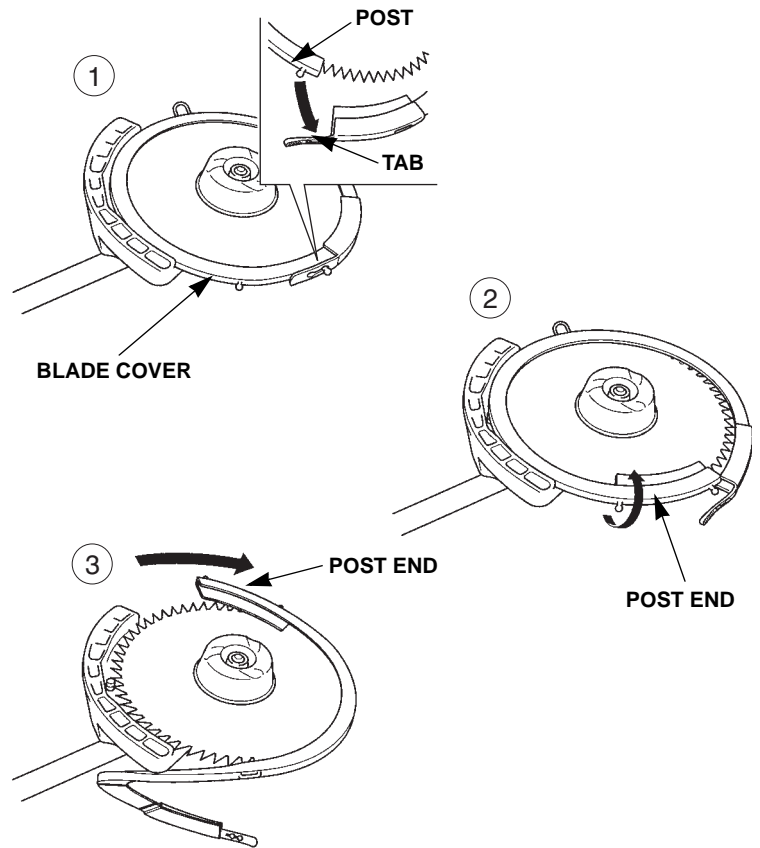

## BLADE COVER INSTALLATION

1. Install the blade cover over the blade so half of the blade is covered.

To prevent the post end from interfering with the debris shield, pull the post end away from the blade and set it on top of the blade as shown.

Turn the blade cover slowly until the post end clears the debris shield.

2. Reposition the post end over the blade.

3. With the blade cover fully seated on the blade, latch the tab over the post.

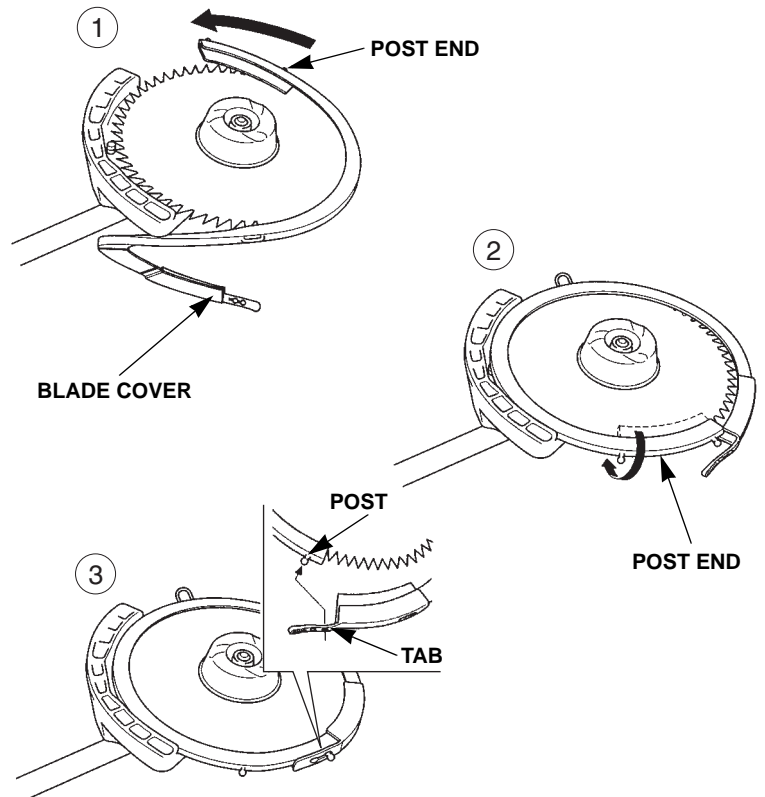



## ENGINE OIL

The trimmer is shipped **WITHOUT OIL** in the engine.

1. Place the trimmer on a level surface then remove the oil filler cap/dipstick.
2. Slowly add the recommended oil (included in the box) to the bottom edge of the oil filler opening. Do not overfill, as the engine oil tank capacity is small.
3. If the supplied oil is not used, add enough SAE 10W-30 API service category SJ or later oil. Add oil until the oil level is to the bottom edge of the oil filler opening.

### NOTICE

*Running the engine with too little or too much oil can cause engine damage.*

4. Screw in the oil filler cap/dipstick securely.

OIL FILLER OPENING

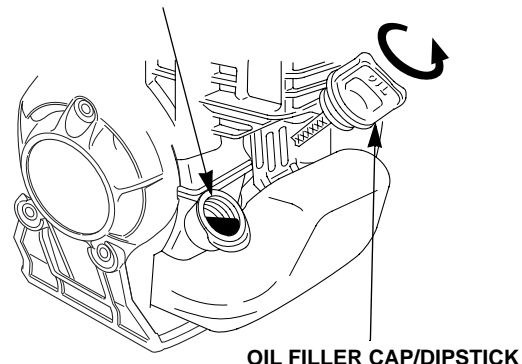

OIL LEVEL  
UPPER  
LIMIT

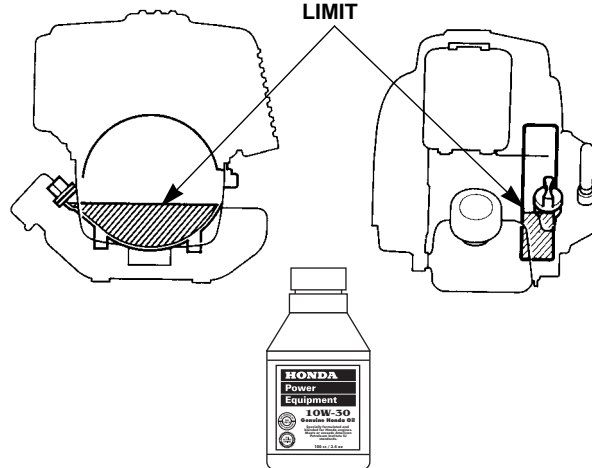

## FUEL

Refer to Refueling section of the *SERVICING YOUR TRIMMER* chapter (page 39).

## BEFORE OPERATION

On blade equipped models, always remove the blade cover before starting the engine. If the cover is not removed, the blade cover may fly off at high speed during test operation. Reinstall the blade cover when the trimmer is not being used.

Before using the trimmer, all trimmer operators must read the following chapters.

- **TRIMMER SAFETY** (page 4)
- **CONTROLS & EQUIPMENT** (page 11)
- **BEFORE OPERATION** (page 14)
- **OPERATION** (page 17)

# STORAGE

## STORAGE PREPARATION

Proper storage preparation is essential to keep your trimmer trouble free and looking good. The following steps will help to keep rust and corrosion from impairing your trimmer's function and appearance, and will make the engine easier to start when you use the trimmer again.

### Cleaning

Wash the trimmer, including the area around the trimmer head.

Wash the engine by hand and be careful to prevent water from entering the air cleaner.

### **NOTICE**

*Using a garden hose or pressure washing equipment can force water into the air cleaner. Water in the air cleaner will soak the filter and can enter the carburetor or engine, causing damage.*

Water on a hot engine can cause damage. If the engine has been running, allow it to cool for at least 1/2 hour before washing.

If using a garden hose or pressure washing equipment to clean the trimmer, be careful to avoid getting water into controls and cable, or anywhere near the engine air cleaner or muffler opening.

Before washing the trimmer head area, disconnect the spark plug cap from the spark plug.

After washing the trimmer, wipe dry all accessible surfaces.

Start the engine outdoors and let it run until it reaches normal operating temperature to evaporate any water remaining on the engine.

Stop the engine and allow it to cool.

After the trimmer is clean and dry, coat areas that may rust with a light film of oil. Lubricate the control cable cores with a silicone spray lubricant.

## Fuel

Gasoline will oxidize and deteriorate in storage. Old gasoline will cause hard starting, and it leaves gum deposits that clog the fuel system. If the gasoline in your trimmer deteriorates during storage, you may need to have the carburetor and other fuel system components serviced or replaced.

The length of time that gasoline can be left in your fuel tank and carburetor without causing functional problems will vary with such factors as gasoline blend, your storage temperatures, and whether the fuel tank is partially or completely filled. The air in a partially filled fuel tank promotes fuel deterioration. Very warm storage temperatures accelerate fuel deterioration. Fuel deterioration problems may occur within a few months, or even less if the gasoline was not fresh when you filled the fuel tank.

The *Distributors Limited Warranty* does not cover fuel system damage or engine performance problems resulting from neglected storage preparation.

You can extend fuel storage life by adding a gasoline stabilizer that is formulated for that purpose, or you can avoid fuel deterioration problems by draining the fuel tank and carburetor.

## ***Adding Fuel Stabilizer to Extend Fuel Storage Life***

When adding a fuel stabilizer, fill the fuel tank with fresh gasoline. If only partially filled, air in the tank will promote fuel deterioration during storage. If you keep a container of gasoline for refueling, be sure that it contains only fresh gasoline.

Add fuel stabilizer following the manufacturer's instructions.

After adding a fuel stabilizer, run the engine outdoors for 10 minutes to be sure that treated gasoline has replaced the untreated gasoline in the carburetor.

## ***Draining the Fuel Tank and Carburetor***

Disconnect the spark plug cap. Make sure the ignition switch is in the STOP (O) position.

Drain the fuel from the fuel tank into a suitable container. Press the primer bulb a few times to draw any remaining fuel out of the carburetor, then drain this fuel from the tank.

## **Engine Oil**

Change the engine oil (see page 26).

## **Carburetor & Air Cleaner**

Clean the air filter (see page 27) and move the choke lever to the CLOSED position.

## **Blade**

If a blade is installed, put the blade cover on the blade.

## **Engine Cylinder**

Remove the spark plug (see page 37). Pour a 1/4 tablespoon (1 ~ 3 cc) of clean engine oil into the cylinder. Pull the starter rope several times to distribute the oil in the cylinder. Reinstall the spark plug. Pull the starter rope slowly until resistance is felt, then return the starter grip gently. This closes the valves so moisture cannot enter.

## **STORAGE PRECAUTIONS**

If your trimmer will be stored with gasoline in the fuel tank and carburetor, it is important to reduce the hazard of gasoline vapor ignition. Select a well-ventilated storage area away from any appliance that operates with a flame, such as a furnace, water heater, or clothes dryer. Also avoid any area with a spark-producing electric motor, or where power tools are operated.

If possible, avoid storage areas with high humidity, because that promotes rust and corrosion.

With the engine and exhaust system cool, cover the trimmer to keep out dust. A hot engine and exhaust system can ignite or melt some materials. Do not use sheet plastic as a dust cover. A non-porous cover will trap moisture, promoting rust and corrosion.

## **REMOVAL FROM STORAGE**

Check your trimmer as described in the *BEFORE OPERATION* chapter of this manual.

If the fuel was drained during storage preparation, fill the tank with fresh gasoline. If you keep a container of gasoline for refueling, be sure that it contains only fresh gasoline. Gasoline oxidizes and deteriorates over time, causing hard starting.

If the cylinder was coated with oil during storage preparation, the engine will smoke briefly at startup. This is normal.

# TRANSPORTING

## BEFORE LOADING

If the engine has been running, allow it to cool for at least 15 minutes before loading the trimmer on the transport vehicle. A hot engine and exhaust system can burn you and can ignite some materials.

Always turn the ignition switch to the STOP (O) position. Make sure the fuel cap is securely tightened.

## LOADING

The trimmer may be secured by suitable clamps, hangers or straps. Secure the trimmer by at least two points along the frame pipe. Avoid securing the trimmer by the engine, cutting head/gear case or handle area. The trimmer should be secured in a horizontal position, with the engine upright as shown.

Don't hang the trimmer by the gear case or cutting head, or they may be damaged.

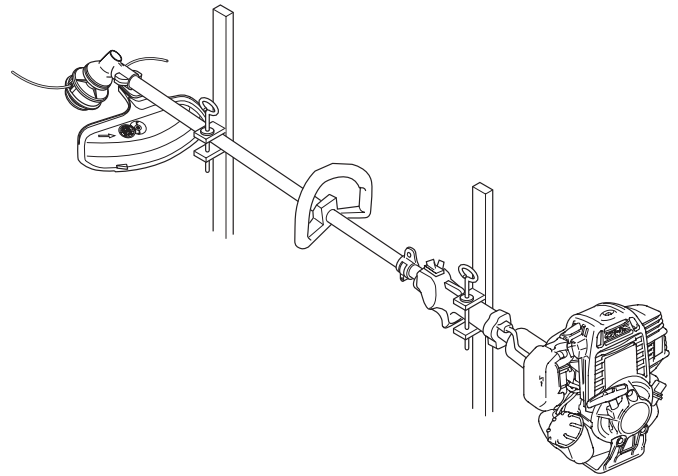

# TAKING CARE OF UNEXPECTED PROBLEMS

## Engine Will Not Start

Possible Cause	Correction
Ignition switch is in the STOP (O) position.	Turn the ignition switch ON (I).
Choke is not in the CLOSED position (cold engine).	Move the choke to the CLOSED position.
Out of fuel.	Add fuel and press the priming bulb to fill the carburetor.
Bad fuel, trimmer stored without treating or draining gasoline, refueled with bad gasoline.	Drain the fuel tank and carburetor, refuel with fresh gasoline.
Spark plug is faulty, fouled, or has incorrect gap.	Clean, gap, or replace the spark plug.
Fuel filter clogged, carburetor malfunction, ignition malfunction, valves stuck, etc.	Replace or repair faulty components as needed.

## Low Power or Engine Speed Won't Increase

Possible Cause	Correction
Air filter is dirty or clogged.	Clean or replace the air filter.
Fuel filter is dirty or clogged.	Replace the fuel filter.
Throttle cable is out of adjustment, broken, or bent.	Adjust the cable or replace it if necessary.
Spark arrester screen clogged.	Clean the screen.
Grass is wrapped around the output shaft and/or cutting attachment.	Move the ignition switch to the STOP (O) position and disconnect the spark plug cap from the spark plug. Remove grass from the output shaft and cutting attachment area.

## Blade or Cutting-line Head Won't Stop Turning When the Throttle is at Slow Position

Possible Cause	Correction
Fault in the throttle control or cable; throttle cable out of adjustment or bent.	Check the throttle control parts; adjust or replace the cable if necessary.
Idle speed is too fast.	Adjust the idle speed.
Broken or worn clutch springs, or faulty clutch system.	Replace the clutch springs or replace or repair other clutch system parts.

## TAKING CARE OF UNEXPECTED PROBLEMS

---

### Blade or Cutting-line Head Won't Turn

Possible Cause	Correction
Worn or broken clutch, broken drive cable, worn or broken gear case parts.	Replace or repair faulty components as needed.

### Excessive Vibration

Possible Cause	Correction
Loose cutting-line head or blade nut.	Tighten the cutting-line head or blade nut securely.
Cutting-line is not wound properly or has unequal line lengths.	Rewind the cutting-line and cut to equal lengths.
Damaged blade.	Replace the blade.

# TECHNICAL & CONSUMER INFORMATION

## TECHNICAL INFORMATION

This chapter contains important information about serial number locations, high altitude operation, oxygenated fuels, and emissions control systems.

### Serial Number Locations

There are two serial numbers, one for the trimmer and one for the engine. Record these numbers in the space provided. You will need to have these numbers available when ordering parts or making technical or warranty inquiries (page 59).

Engine serial number: \_\_\_\_\_

Frame serial number: \_\_\_\_\_

Date of purchase: \_\_\_\_\_

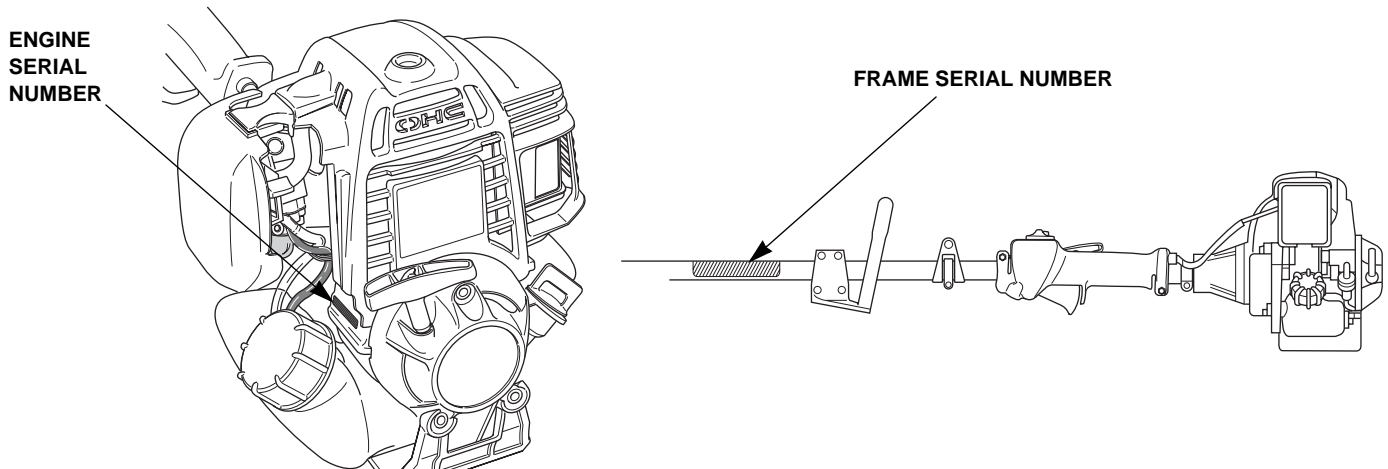

### Carburetor Modifications for High Altitude Operation

At high altitude, the standard carburetor air-fuel mixture will be too rich. Performance will decrease, and fuel consumption will increase. A very rich mixture will also foul the spark plug and cause hard starting. Operation at an altitude that differs from that at which this engine was certified, for extended periods of time, may increase emissions.

High altitude performance can be improved by specific modifications to the carburetor. If you always operate your trimmer at altitudes above 5,000 feet (1,500 meters), have your servicing dealer perform this carburetor modification. This engine, when operated at high altitude with the carburetor modifications for high altitude use, will meet each emission standard throughout its useful life.

Even with carburetor modification, engine horsepower will decrease about 3.5% for each 1,000-foot (300-meter) increase in altitude. The effect of altitude on horsepower will be greater than this if no carburetor modification is made.

#### **NOTICE**

*When the carburetor has been modified for high altitude operation, the air-fuel mixture will be too lean for low altitude use. Operation at altitudes below 5,000 feet (1,500 meters) with a modified carburetor may cause the engine to overheat and result in serious engine damage. For use at low altitudes, have your servicing dealer return the carburetor to original factory specifications.*

## TECHNICAL & CONSUMER INFORMATION

---

### Oxygenated Fuels

Some conventional gasolines are being blended with alcohol or an ether compound. These gasolines are collectively referred to as oxygenated fuels. To meet clean air standards, some areas of the USA and Canada use oxygenated fuels to help reduce emissions. If you use an oxygenated fuel, be sure it is unleaded and meets the minimum octane rating requirement. Before using an oxygenated fuel, try to confirm the fuel's contents. Some states/provinces require this information to be posted on the pump.

The following are the EPA approved percentages of oxygenates:

**ETHANOL** — (ethyl or grain alcohol) 10% by volume

You may use gasoline containing up to 10% ethanol by volume. Gasoline containing ethanol may be marketed under the name "Gasohol."

**MTBE** — (Methyl Tertiary Butyl Ether) 15% by volume

You may use gasoline containing up to 15% MTBE by volume.

**METHANOL** — (methyl or wood alcohol) 5% by volume

You may use gasoline containing up to 5% methanol by volume, as long as it also contains cosolvents and corrosion inhibitors to protect the fuel system. Gasoline containing more than 5% methanol by volume may cause starting and/or performance problems. It may also damage metal, rubber, and plastic parts of your fuel system.

If you notice any undesirable operating symptoms, try another service station or switch to another brand of gasoline. Fuel system damage or performance problems resulting from the use of an oxygenated fuel containing more than the percentages of oxygenates mentioned above are not covered under the *Distributor's Limited Warranty*.



## EMISSION CONTROL SYSTEM

### Source of Emissions

The combustion process produces carbon monoxide, oxides of nitrogen, and hydrocarbons. Control of hydrocarbons and oxides of nitrogen is very important because, under certain conditions, they react to form photochemical smog when subjected to sunlight. Carbon monoxide does not react in the same way, but it is toxic.

Honda utilizes lean carburetor settings and other systems to reduce the emissions of carbon monoxide, oxides of nitrogen, and hydrocarbons.

### The U.S., California Clean Air Act and Environment Canada

EPA, California and Canadian regulations require all manufacturers to furnish written instructions describing the operation and maintenance of emissions control systems.

The following instructions and procedures must be followed in order to keep the emissions from your Honda engine within the emissions standards.

### Tampering and Altering

Tampering with or altering the emissions control system may increase emissions beyond the legal limit. Among those acts that constitute tampering are:

- Removal or alteration of any part of the intake, fuel, or exhaust systems.
- Altering or defeating the speed-adjusting mechanism to cause the engine to operate outside its design parameters.

### Problems That May Affect Emissions

If you are aware of any of the following symptoms, have your engine inspected and repaired by your servicing dealer.

- Hard starting or stalling after starting
- Rough idle
- Misfiring or backfiring under load
- Afterburning (backfiring)
- Black exhaust smoke or high fuel consumption

### Replacement Parts

The emissions control systems on your new Honda engine were designed, built, and certified to conform with EPA, California and Canadian emissions regulations. We recommend the use of genuine Honda parts whenever you have maintenance done. These original-design replacement parts are manufactured to the same standards as the original parts, so you can be confident of their performance. The use of replacement parts that are not of the original design and quality may impair the effectiveness of your emissions control system.

A manufacturer of an aftermarket part assumes the responsibility that the part will not adversely affect emissions performance. The manufacturer or rebuilder of the part must certify that use of the part will not result in a failure of the engine to comply with emissions regulations.

### Maintenance

Follow the *Maintenance Schedule* on page 25. Remember this schedule is based on the assumption that your machine will be used for its designed purpose. Sustained high-load or high-temperature operation, or use in unusually wet or dusty conditions, will require more frequent service.

## TECHNICAL & CONSUMER INFORMATION

---

### Air Index

An Air Index Information hang tag/label is applied to engines certified to an emission durability time period in accordance with the requirements of the California Air Resources Board.

The bar graph is intended to provide you, our customer, the ability to compare the emissions performance of available engines. The lower the Air Index, the less pollution.

The durability description is intended to provide you with information relating the engine's emission durability period. The descriptive term indicates the useful life period for the engine's emission control system. See your *Emission Control System Warranty* for additional information.

<b>Descriptive Term</b>	<b>Applicable to Emissions Durability Period</b>
Moderate	50 hours (0–65 cc) 125 hours (greater than 65 cc)
Intermediate	125 hours (0–65 cc) 250 hours (greater than 65 cc)
Extended	300 hours (0–65 cc) 500 hours (greater than 65 cc)

The Air Index Information hang tag/label must remain on the trimmer/brush cutter until it is sold. Remove the hang tag before operating the trimmer/brush cutter.

# TECHNICAL & CONSUMER INFORMATION

## SPECIFICATIONS

FEATURES			
	HHT25SLTAT	HHT35SLTAT	HHT35SUKAT
GX25 1.1 hp	•		
GX35 1.6 hp		•	•
Loop handle	•	•	
U-type handlebar			•
Manual feed head	optional	optional	•
Semi-matic feed head	•	•	optional
Saw blade	optional (requires optional Barrier Kit)	optional (requires optional Barrier Kit)	•

DIMENSIONS				
	Handle Installed		HHT25S	HHT35S
Length	Loop	Manual feed head	73.4 in (1865 mm)	73.8 in (1875 mm)
		Semi-matic feed head	73.4 in (1865 mm)	73.8 in (1875 mm)
	U-type <sup>1</sup>		74.4 in (1890 mm)	75.0 in (1905 mm)
Width	Loop		12.8 in (325 mm)	
	U-type		23.6 in (600 mm)	
Height	Loop		9.6 in (245 mm)	10.2 in (260 mm)
	U-type		15.9 in (405 mm)	
Dry weight	Loop		12.1 lb (5.5 kg)	14.8 lb. (6.7 kg)
	U-type		12.8 lb (5.8 kg)	15.4 lb. (7.0 kg)

<sup>1</sup>with saw blade installed

## Tuneup

ITEM	SPECIFICATION	MAINTENANCE
Spark plug gap	0.024 - 0.028 in (0.60 - 0.70 mm)	Refer to page 37
Valve clearance (cold)	Intake: 0.08 ± 0.02 mm Exhaust: 0.11 ± 0.02 mm	See your authorized servicing Honda dealer

## TECHNICAL & CONSUMER INFORMATION

ENGINE		
	HHT25S	HHT35S
Model	GX25	GX35
Engine type	4-stroke, overhead-cam, single-cylinder	
Displacement	1.5 cu in (25.0 cc)	2.2 cu in (35.8 cc)
Bore & stroke	1.4 x 1.0 in (35 x 26 mm)	1.5 x 1.2 in (39 x 30 mm)
Maximum output*	1.1 hp (0.81 kW) at 7,000 rpm	1.6 hp (1.2 kW) at 7,000 rpm
Maximum torque	0.92 ft-lbs (1.25 N•m) at 5,000 rpm	1.4 ft-lbs (1.9 N•m) at 5,500 rpm
Ignition system	Transistorized magneto	
Spark plug	NGK: CMR5H	
Starting system	Recoil	
Fuel	Unleaded gasoline (86 octane or higher)	
Fuel tank capacity	0.13 US gal, 16.9 fl.oz. (0.50 ℓ)	0.17 US gal, 22.0 fl oz (0.65ℓ)
Fuel consumption	0.55 lb/hph (340 g/kWh, 250 g/psh)	0.59 lb/hph (360 g/kWh, 265 g/psh)
Oil capacity	2.7 fl oz (80 cc)	3.4 fl oz (100 cc)
Carburetor type	Diaphragm type (overflow return) with fuel pump	
Air cleaner	Single element, semi-dry	
Idle speed	3,100 ± 200 rpm	

\* Horsepower rating (shown as maximum power output at 7,000 rpm) is in accordance with SAE J1995. Actual engine power will be lower. Engine power depends on accessories, operating speeds, operating conditions, and other variables.

FRAME			
		HHT25S	HHT35S
Ignition switch		Slide type	
Throttle control		Two-motion trigger style	
Frame pipe	OD	1.0 in (25.4 mm)	
	Thickness	0.059 in (1.5 mm)	
Drive	Type	Material	Flexible steel cable
		OD	0.25 in (6.3 mm)
	Engagement	0.20 in (5 mm) square drive both ends	
	Bushing	Material	Nylon
Length		57.5 in (1460 mm)	
Gear case	Ratio	1.24 (input shaft) : 1 (output shaft)	
	Type	Ball bearings, helical cut gears, no shims required	
Clutch	Size	2.18 in (55.2 mm)	3.09 in (78.4 mm)
	Engagement	4,200 ± 200 rpm	
	Drive	Square female	
	Type	Centrifugal	

# TECHNICAL & CONSUMER INFORMATION

## CONSUMER INFORMATION

### Dealer Locator Information

To find an Authorized Honda Servicing Dealer anywhere in the United States:

Call (800) 426-7701

or visit our website:

[www.hondapowerequipment.com/dealer](http://www.hondapowerequipment.com/dealer)

### Customer Service Information

Honda Power Equipment dealership personnel are trained professionals. They should be able to answer any question you may have. If you encounter a problem that your dealer does not solve to your satisfaction, please discuss it with the dealership's management. The Service Manager or General Manager can help. Almost all problems are solved in this way.

If you are dissatisfied with the decision made by the dealership's management, contact the Honda Power Equipment Customer Relations Office. You can write:

**American Honda Motor Co., Inc.**

Power Equipment Division

Customer Relations Office

4900 Marconi Drive

Alpharetta, GA 30005-8847

Or telephone: (770) 497-6400 M-F, 8:30 a.m. - 8:00 p.m. EST

When you write or call, please give us this information:

- Model and serial numbers (page 53)
- Name of the dealer who sold the trimmer to you
- Name and address of the dealer who services your trimmer
- Date of purchase
- Your name, address, and telephone number
- A detailed description of the problem

### Honda Publications

These publications will give you additional information for maintaining and repairing your trimmer.

#### Shop Manual

This manual covers complete maintenance and overhaul procedures. It is intended to be used by a skilled technician. Available through your Honda dealer or through Helm Inc. at (888) 292-5395 or visit

[www.hondapowerequipment.com/product\\_manuals](http://www.hondapowerequipment.com/product_manuals)

#### Parts Catalog

This manual provides complete, illustrated parts lists, and is available through your Honda dealer.

## Replacement Parts, Optional Equipment, and Service Items

Contact an authorized Honda servicing dealer to purchase any of these (or other) genuine original Honda items.

### Replacement Parts

Item	Part Number	Notes
Air cleaner element	17211-Z0H-000	
Spark plug	31915-Z0H-003	NGK: CMR5H
Cutting-line manual-feed	72512-095-0855Q	.095" spool
Cutting-line semi-matic (bump-feed)	72512-095-0285Q	.095" doughnut

### Optional Equipment

Item	Part Number	Notes
Fast funnel	08C25-FST-000	Disposable and spill free
ECO gas can	06176-0020	2 gallon spill-control type (CARB)
Barrier kit	06631-VH8-740	Use with saw blade

### Service Items

Item	Part Number	Notes
SAE 10W-30 engine oil	08207-10W30	Genuine Honda recommended oil
Fuel stabilizer	08732-0001	For long term storage

# TECHNICAL & CONSUMER INFORMATION

## Distributor's Limited Warranty

This warranty is limited to the following Honda Power Equipment products when distributed by American Honda Motor Co., Inc., Power Equipment Division, 4900 Marconi Drive, Alpharetta, Georgia 30005-8847.

PRODUCTS COVERED BY THIS WARRANTY	LENGTH OF WARRANTY* (from date of original retail purchase)	
	Noncommercial/Nonrental	Commercial/Rental
Hand-Held Products (limited lifetime warranty on the HHT drive cable)	24 months	12 months/3 months
<b>Mowers/Tractors, Tillers, Snowblowers/Snowthrowers</b>		
Masters, HRX, Harmony and Harmony II	24 months	3 months
HRX and Harmony Xenoy® Mower Decks	60 months	3 months
HRC Series 21-Inch Walk Behind Mowers	24 months	24 months engine, 12 months other components
Riding Mowers	24 months	3 months
Lawn Tractors	24 months	12 months/3 months
Tillers FC600, FRC800	24 months	24 months engine, 12 months other components
Tillers (all others)	24 months	3 months
Snowblowers/Snowthrowers	24 months	24 months engine, 12 months other components
<b>Water Pumps</b>		
Engine WX10	24 months	12 months/3 months
Engine WN20, WN30	24 months	3 months
Engine (all others)	24 months	24 months
Centrifugal Pumps WB20XK2 and WB30XK2	24 months	12 months
Centrifugal Pumps (all others)	24 months	3 months
Diaphragm Pump and Frame Components	12 months	12 months
Electric Submersible Pumps	12 months	12 months
<b>Generators (Excluding Recreational Vehicle Types)</b>		
Generator EN2500	12 months	3 months
Generator (all others)	24 months	24 months engine, 12 months other components

\* Length of Warranty: Batteries supplied with applicable products as standard, original equipment are covered by this warranty for a period of 12 months (noncommercial use) or 3 months (commercial/rental use) from the date of original retail product purchase.

### To Qualify For This Warranty:

The product must be purchased in the United States, Puerto Rico, or the U.S. Virgin Islands from American Honda or a dealer authorized by American Honda to sell those products. This warranty applies to first retail purchaser and each subsequent owner during the applicable warranty time period.

### What American Honda Will Repair Or Replace Under Warranty:

American Honda will repair or replace, at its option, any part that is proven to be defective in material or workmanship under normal use during the applicable warranty time period. Warranty repairs and replacements will be made without charge for parts or labor. Anything replaced under warranty becomes the property of American Honda Motor Company, Inc. All parts replaced under warranty will be considered as part of the original product and any warranty on those parts will expire coincident with the original product warranty.

### To Obtain Warranty Service:

You must take the Honda Power Equipment product, accessory, replacement part, apparel or the power equipment on which the accessory or replacement part is installed, and proof of purchase, at your expense, to any Honda Power Equipment dealer in the United States, Puerto Rico, or the U.S. Virgin Islands who is authorized to sell that product, during the dealer's normal business hours. If you are unable to obtain warranty service, or are dissatisfied with the warranty service you receive, take the following steps: First, contact the owner of the dealership involved; normally this will resolve the problem. However, if you should require further assistance, write or call the Power Equipment Customer Relations Department of American Honda Motor Co., Inc.

American Honda Motor Co., Inc.  
Power Equipment Customer Relations Dept.  
4900 Marconi Drive  
Alpharetta, GA 30005-8847 Telephone: (770) 497-6400

### Exclusions:

This warranty does not extend to parts affected or damaged by accident and/or collision, normal wear, fuel contamination or deterioration, use in an application for which the product was not designed or any other misuse, neglect, incorporation or use of unsuitable attachments or parts, unauthorized alteration, or any causes other than defects in material or workmanship of the product.

The auger and paddle assemblies of snowthrowers, tiller tines of roto-tillers, mower blades and mower deck housings, are specifically not warranted against impact damage, including but not limited to, abrasive damage.

### Disclaimer of Consequential Damage and Limitation of Implied Warranties:

American Honda disclaims any responsibility for loss of time or use of the product, transportation, commercial loss, or any other incidental or consequential damage. Any implied warranties are limited to the duration of this written limited warranty. Some states do not allow limitations on how long an implied warranty lasts and/or do not allow the exclusion or limitation of incidental or consequential damages, so the above exclusions and limitations may not apply to you.

This warranty gives you specific legal rights, and you may also have other rights which vary from state to state.

# TECHNICAL & CONSUMER INFORMATION

## Accessories, Replacement Parts, and Apparel Warranty

This warranty is limited to Honda Power Equipment parts, accessories and apparel when distributed by American Honda Motor Co., Inc., 4900 Marconi Drive, Alpharetta, Georgia 30005-8847

PRODUCTS COVERED BY THIS WARRANTY	LENGTH OF WARRANTY (from date of original retail purchase)	
	Noncommercial/Nonrental	Commercial/Rental
Accessories	12 months	3 months
Replacement Parts	6 months	3 months
Apparel	6 months	3 months

### To Qualify for this Warranty:

1. The accessories, replacement parts, or apparel must be purchased from American Honda, or a dealer, distributor or distributor's dealer authorized by American Honda to sell those products in the United States, Puerto Rico, and the U.S. Virgin Islands.
2. You must be the first retail purchaser. This warranty is not transferable to subsequent owners.

### What American Honda will Repair or Replace Under Warranty:

American Honda will repair or replace, at its option, any power equipment accessories, replacement parts, or apparel that are proven to be defective in material or workmanship under normal use during the applicable warranty time period. Anything replaced under warranty becomes the property of American Honda Motor Company, Inc. All parts replaced under warranty will be considered as part of the original product and any warranty on those parts will expire coincident with the original product warranty.

Accessories and replacement parts, installed by a dealer who is authorized by American Honda to sell them, will be repaired or replaced under warranty without charge for parts or labor. If installed by anyone else, accessories and replacement parts will be repaired or replaced under warranty without charge for parts, but any labor charges will be the responsibility of the purchaser. Apparel will be repaired or replaced under warranty without any charge.

### To Obtain Warranty Service:

You must take the Honda Power Equipment accessory, replacement part, apparel or the power equipment on which the accessory or replacement part is installed, and proof of purchase, at your expense, to any Honda Power Equipment dealer in the United States, Puerto Rico, or the U.S. Virgin Islands who is authorized to service that product, during the dealer's normal business hours. If you are unable to obtain warranty service, or are dissatisfied with the warranty service you receive, take the following steps: First, contact the owner of the dealership involved; normally this will resolve the problem. However, if you should require further assistance, write or call the Power Equipment Customer Relations Department of American Honda Motor Co., Inc. Refer to page 59 for contact information.

### Exclusions:

This warranty does not extend to accessories, parts, or apparel affected or damaged by accident and/or collision, normal wear, use in an application for which the product was not designed, or any other misuse, neglect, incorporation or use of unsuitable attachments or parts, unauthorized alteration, improper installation, or any causes other than defects in material or workmanship of the product.

Mower blades and mower deck housings, are specifically not warranted against impact damage, including but not limited to, abrasive damage.

### Disclaimer of Consequential Damage and Limitation of Implied Warranties:

American Honda disclaims any responsibility for loss of time or use of the product, or the power equipment on which the product is installed, transportation, commercial loss, or any other incidental or consequential damage. Any implied warranties are limited to the duration of this written warranty. Some states do not allow limitations on how long an implied warranty lasts and/or do not allow the exclusion or limitation of incidental or consequential damages, so the above exclusions and limitations may not apply to you. This warranty gives you specific legal rights, and you may also have other rights which vary from state to state.

# TECHNICAL & CONSUMER INFORMATION

## Emission Control System Warranty

Your new Honda Power Equipment engine complies with the U.S. EPA, Environment Canada and State of California emission regulations. American Honda Motor Co., Inc. provides the emission warranty coverage for engines in the United States, and its territories. Honda Canada Inc. provides the emission warranty for engines in the 13 provinces and territories of Canada. In the remainder of this Emission Control System Warranty, American Honda Motor Company Inc. and Honda Canada Inc. will be referred to as Honda.

### Your Warranty Rights And Obligations:

#### California

The California Air Resources Board and Honda are pleased to explain the emission control system warranty on your Honda Power Equipment engine. In California, new utility and lawn and garden equipment engines must be designed, built and equipped to meet the State's stringent anti-smog standards.

#### Other States, U.S. territories and Canada

In other areas of the United States and in Canada, your engine must be designed, built, and equipped to meet the U.S. EPA and Environment Canada emission standards for spark-ignited engines at or below 19 kilowatts.

#### All of the United States and Canada

Honda must warrant the emission control system on your power equipment engine for the period of time listed below provided there has been no abuse, neglect or improper maintenance of your power equipment engine. Where a warrantable condition exists, Honda will repair your power equipment engine at no cost to you including diagnosis, parts and labor.

Your emission control system may include such parts as the carburetor or fuel injection system, the ignition system, and catalytic converter. Also included may be hoses, connectors and other emission-related assemblies.

#### Manufacturer's Warranty Coverage:

The 1995 and later power equipment engines are warranted for two years. If any emission-related part on your engine is defective, the part will be repaired or replaced by Honda.

#### Owner's Warranty Responsibility:

As the power equipment engine owner, you are responsible for the performance of the required maintenance listed in your owner's manual. Honda recommends that you retain all receipts covering maintenance on your power equipment engine, but Honda cannot deny warranty coverage solely for the lack of receipts or for your failure to ensure the performance of all scheduled maintenance.

As the power equipment engine owner, you should however be aware that Honda may deny you warranty coverage if your power equipment engine or a part has failed due to abuse, neglect, improper maintenance, or unapproved modifications.

You are responsible for presenting your power equipment engine to a Honda Power Equipment dealer as soon as a problem exists. The warranty repairs should be completed in a reasonable amount of time, not to exceed 30 days.

If you have any questions regarding your warranty rights and responsibilities, you should write or call the Honda office in your region.

American Honda Motor Co., Inc.  
Power Equipment Customer Relations  
4900 Marconi Drive  
Alpharetta, Georgia 30005-8847  
Telephone: (770) 497-6400

or

Honda Canada Inc.  
Power Equipment Customer Relations  
715 Milner Avenue  
Toronto, ON M1B 2K8  
Telephone: (888) 946-6329

#### Warranty Coverage:

Honda power equipment engines manufactured after January 1, 1995 and sold in the State of California, and U.S. EPA certified engines manufactured on or after September 1, 1996 and sold in all of the United States, and Canadian certified engines manufactured on or after January 1, 2005 are covered by this warranty for a period of two years from the date of delivery to the original retail purchaser. This warranty is transferable to each subsequent purchaser for the duration of the warranty period.

Warranty repairs will be made without charge for diagnosis, parts or labor. All defective parts replaced under this warranty become the property of Honda. Warranted parts are listed under *Emission Control System Warranty Parts* listed below. Normal maintenance items, such as spark plugs and filters, that are on the warranted parts list are warranted up to their required replacement interval only.

Honda is also liable for damages to other engine components caused by a failure of any warranted part during the warranty period.

Only Honda approved replacement parts may be used in the performance of any warranty repairs and must be provided without charge to the owner. The use of replacement parts not equivalent to the original parts may impair the effectiveness of your engine emission control system. If such a replacement part is used in the repair or maintenance of your engine, and an authorized Honda dealer determines it is defective or causes a failure of a warranted part, your claim for repair of your engine may be denied. If the part in question is not related to the reason your engine requires repair, your claim will not be denied.

#### To Obtain Warranty Service:

You must take your Honda Power Equipment engine or the product on which it is installed, along with your warranty registration card or other proof of original purchase date, at your expense, to any Honda Power Equipment dealer who is authorized by Honda to sell and service that Honda product during his normal business hours. Claims for repair or adjustment found to be caused solely by defects in material or workmanship will not be denied because the engine was not properly maintained and used.

If you are unable to obtain warranty service, or are dissatisfied with the warranty service you received, contact the owner of the dealership involved. Normally this should resolve your problem. However, if you require further assistance, write or call the Power Equipment Customer Relations Department of American Honda Motor Co., Inc. Refer to page 59 for contact information.

#### Exclusions:

Failures other than those resulting from defects in material or workmanship are not covered by this warranty. This warranty does not extend to emission control systems or parts which are affected or damaged by owner abuse, neglect, improper maintenance, misuse, misfueling, improper storage, accident and/or collision, the incorporation of, or any use of, any add-on or modified parts, unsuitable attachments, or the unauthorized alteration of any part.

This warranty does not cover replacement of expendable maintenance items made in connection with required maintenance services after the item's first scheduled replacement as listed in the maintenance section of the product owner's manual, such as: spark plugs and filters.

#### Disclaimer of Consequential Damage and Limitation of Implied Warranties:

American Honda Motor Co., Inc. and Honda Canada Inc. disclaim any responsibility for incidental or consequential damages such as loss of time or the use of the power equipment, or any commercial loss due to the failure of the equipment; and any implied warranties are limited to the duration of this written warranty. This warranty is applicable only where the California, U.S. EPA or Environment Canada Emission Control System Warranty regulation is in effect.

#### Emission Control System Warranty Parts:

SYSTEMS COVERED BY THIS WARRANTY:	PARTS DESCRIPTION:
Fuel Metering	Carburetor assembly, (includes starting enrichment system), Engine temperature sensor, Engine control module, Fuel regulator, Intake manifold
Evaporative	Fuel hoses
Exhaust	Catalyst, Exhaust manifold
Air Induction	Air filter housing, Air filter element*, Crankcase breather tube
Ignition	Flywheel magneto, Ignition pulse generator, Crankshaft position sensor, Power coil, Ignition coil assembly, Ignition control module, Spark plug cap, Spark plug*
Miscellaneous Parts	Tubing, fittings, seals, gaskets, and clamps associated with these listed systems.

\* Covered up to the first required replacement only.

See the *Maintenance Schedule* on page 25.



<b>A</b>	
Accessories warranty .....	61
Air filter	
Check .....	27
Cleaning .....	27
Air index .....	56
Assembly .....	41
Loose parts .....	42
Trimmer assembly .....	43
Unpacking .....	42
<b>B</b>	
Before operation .....	14
Blade	
Inspection .....	35
Removal/installation .....	35
Usage .....	21
Blade thrust .....	22
Brush/wood blade cover .....	9
<b>C</b>	
Carburetor adjustment .....	53
Choke lever .....	11
Clothing recommendations .....	4
Cooling fin inspection .....	39
Cutting attachments	
Applications .....	9
Blades and shields .....	8
Inspection .....	29
Installing replacement line .....	29
Recommendations .....	7
Cutting head	
Problems .....	51
Replacing bump feed head .....	32
Replacing manual feed .....	30
<b>D</b>	
Damage prevention message definition .....	1
Dealer locator information .....	59
Debris shield	
Changing .....	36
Usage .....	21
Description of controls .....	11
Distributor's warranty .....	60
<b>E</b>	
Emission control system .....	55
Emissions	
Warranty .....	62
Engine	
Fuel recommendations .....	39
Oil change .....	26
Oil level .....	26
Oil recommendations .....	27
Operating problems .....	51
Priming bulb .....	12
Serial number .....	53
Switch .....	11
<b>F</b>	
Frame serial number .....	53
Fuel	
Additive to extend storage life .....	49
Draining .....	49
Gasoline recommendations .....	39
Refueling .....	39
<b>G</b>	
Gasoline recommendations .....	39
<b>I</b>	
Ignition switch .....	11
Inspection before trimming/cutting	
Shoulder harness .....	16
Trimmer/cutter .....	15
Trimming/cutting area .....	14
<b>K</b>	
Kickback .....	22
<b>L</b>	
Loop handle	
Installing safety equipment .....	21
Metal blade and barrier kit .....	8

# INDEX

---

## M

Maintenance	
Air filter .....	27
Engine oil .....	26
Fuel system .....	39
Idle speed .....	25
Importance .....	24
Safety .....	24
Schedule .....	25
Spark plug .....	37
Throttle cable .....	28

## O

Oil, engine	
Changing .....	26
Level check .....	26
Recommendations .....	27
Operating the trimmer .....	19
Brush clearing .....	23
Scything .....	22
Slopes .....	23
Tips .....	22
Operator presence lever .....	11
Oxygenated fuels .....	54

## P

Parts	
Catalog .....	59
Replacement list .....	59
Priming bulb .....	12
Publications .....	59

## R

Recoil starter .....	12
Replacement parts .....	55

## S

Safe operating practices .....	21
Safety	
Attachments and modifications .....	5
Important message to employers .....	5
Important safety information .....	4
Precautions .....	17
Safety label locations .....	6
Serial numbers .....	53
Shop manual ordering .....	59

Shoulder harness .....	13
Adjustment .....	16
Quick disconnection .....	19
Quick release latch .....	13
Spark plug service .....	37
Specifications .....	57
Starting problems .....	51
Starting the engine .....	17
Stopping the engine .....	19
Storage .....	48

## T

Throttle	
Cable inspection/adjustment .....	28
Operation .....	11, 20
Transporting .....	50
Trimmer head	
Removing/installing .....	34

## V

Vibrations .....	52
------------------	----

## W

Warranty	
Accessories & parts .....	61
Distributor's .....	60
Emissions .....	62

# QUICK REFERENCE INFORMATION

Fuel	Type	Unleaded gasoline with a pump octane rating of 86 or higher (page 39)
Engine oil	Type	SAE 10W-30, API SJ or later (page 27)
Spark plug	Type	NGK: CMR5H
Maintenance	Before each use	Check engine oil (page 26) Check air filter (page 27) Check throttle cable (page 28) Check cutting attachment (pages 29 and 32) Check debris shield (pages 29) Check nuts, bolts, fasteners Check shoulder harness, quick release (page 19)
	First 10 hours	Change engine oil (page 26)
	Subsequent	Refer to the Maintenance Schedule (page 25)

# HONDA

The Power of Dreams

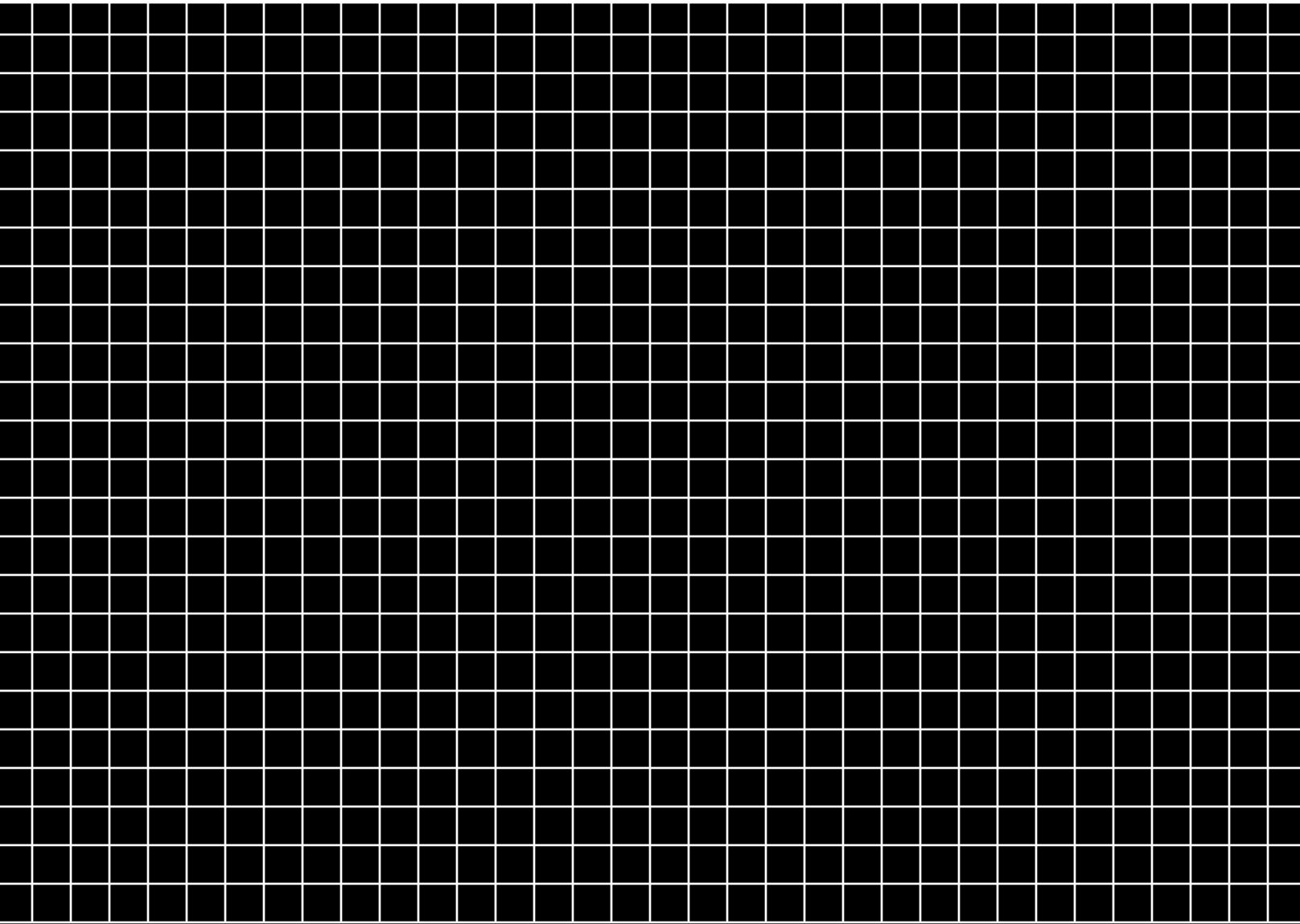

31VL3D00  
00X31-VL3-D000



Printed on  
Recycled Paper



POM53509B  
IPC XXXX.2006.01  
Printed in U.S.A.