

HONDA

Power

Equipment

Owner's Manual
Diaphragm Pump
WDP20X • WDP30X

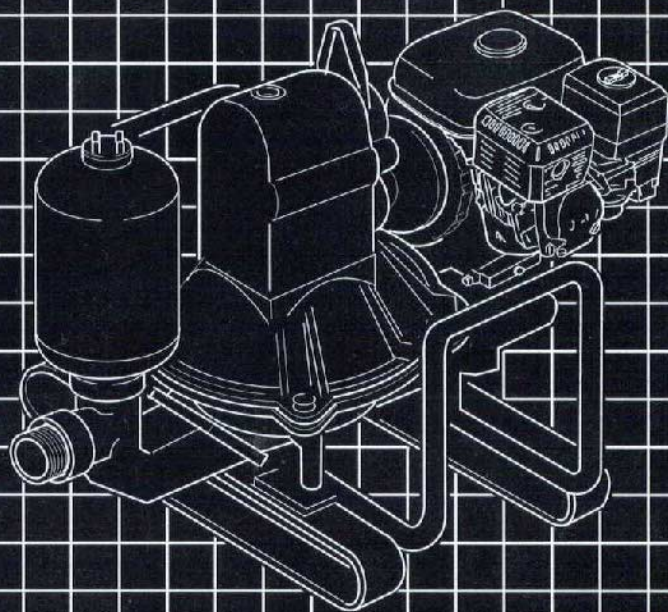



WARNING:



The engine exhaust from this product contains chemicals known to the State of California to cause cancer, birth defects or other reproductive harm.

This owner's manual is considered a permanent part of your diaphragm pump. It must be available to all operators of the pump and should remain with the pump if resold.

The information and specifications in this publication were in effect at the time of approval for printing. American Honda Motor Co., Inc. reserves the right to discontinue or change specifications or design at any time without notice and without incurring any obligation whatever. No part of this publication may be reproduced without written permission.

Congratulations on your selection of a Honda diaphragm pump. We are certain you will be pleased with your purchase of one of the finest pumps on the market.

We want to help you get the best results from your new pump and to operate it safely. This manual contains the information on how to do that; please read it carefully.

As you read this manual, you will find information preceded by a **NOTICE** symbol. That information is intended to help you avoid damage to your pump, other property, or the environment.

We suggest you read the warranty policy to fully understand its coverage and your responsibilities of ownership. The warranty policy is a separate document that should have been given to you by your dealer.

When your pump needs scheduled maintenance, keep in mind that your authorized Honda servicing dealer is specially trained in servicing Honda pumps and is supported by the parts and service divisions of American Honda. Your Honda dealer is dedicated to your satisfaction and will be pleased to answer your questions and concerns.

Best Wishes,
Power Equipment Division
American Honda Motor Co., Inc.

INTRODUCTION

A FEW WORDS ABOUT SAFETY

Your safety, and the safety of others, are very important. And using this pump safely is an important responsibility.

To help you make informed decisions about safety, we have provided operating procedures and other information on labels and in this manual. This information alerts you to potential hazards that could hurt you or others.

Of course, it is not practical or possible to warn you about all the hazards associated with operating or maintaining a pump. You must use your own good judgment.

You will find important safety information in a variety of forms, including:

- **Safety Label** – on the pump.
- **Safety Messages** – preceded by a safety alert symbol  and one of three words: DANGER, WARNING, or CAUTION.

These signal words mean:

 **DANGER**

You **WILL** be **KILLED** or **SERIOUSLY HURT** if you don't follow instructions.

 **WARNING**

You **CAN** be **KILLED** or **SERIOUSLY HURT** if you don't follow instructions.

 **CAUTION**

You **CAN** be **HURT** if you don't follow instructions.

- **Safety Headings** – such as **IMPORTANT SAFETY INFORMATION**.
- **Safety Section** – such as **PUMP SAFETY**.
- **Instructions** – how to use this pump correctly and safely.

This entire book is filled with important safety information – please read it carefully.

CONTENTS

Turn to the beginning of each chapter for a complete list of subjects.

PUMP SAFETY	5
Important information about some specific hazards, and what you can do to prevent injury.	
CONTROLS	9
Identification of components and information about how the controls work.	
BEFORE OPERATION	13
How to prepare your pump and yourself before you begin pumping.	
OPERATION	17
Starting and stopping the engine, safe pumping practices, and pumping tips.	
TRANSPORTING	27
How to load and carry your pump safely	
MAINTENANCE	29
When and how to perform routine inspection, service, and adjustments to keep your pump in good operating condition.	
TROUBLESHOOTING	53
What to check if you have a problem with your pump.	
STORAGE	55
How to protect your pump from rust and corrosion, and ensure that it will start easily when you want to use it again.	
SPECIFICATIONS	61
Specifications, dimensions, capacities, and other technical information.	
ADDITIONAL INFORMATION	65
Additional information, Honda publications available to you, and how to contact us if you have a question or a warranty repair problem.	
INDEX	71
QUICK REFERENCE INFORMATION . . .	inside back cover

PUMP SAFETY

This chapter explains what you need to know to operate your diaphragm pump safely.

IMPORTANT SAFETY INFORMATION	6
Operator Responsibility	6
Pump Operation	6
Refuel With Care	6
Hot Exhaust	7
Carbon Monoxide Hazards	7
SAFETY LABEL LOCATION	8

PUMP SAFETY

IMPORTANT SAFETY INFORMATION

Honda WDP20X and WDP30X pumps are not designed to pump drinking water. Pump only non-potable water, muddy water, and water containing solids. Other uses can result in injury to the operator or damage to the pump and other property.

Most accidents can be prevented if you follow all instructions in this manual and on the pump. The most common hazards are discussed below, along with the best way to protect yourself and others.

Operator Responsibility

It is the operator's responsibility to provide the necessary safeguards to protect people and property. Know how to stop the pump quickly in case of emergency. Understand the use of all controls and connections. For your safety and the safety of others, keep all shields in place when the engine is running.

Be sure that anyone who operates the pump receives proper instruction. Do not let children operate the pump. Keep children, pets, and bystanders away from the area of operation.

Pump Operation

Do not pump drinking water. Pumps are designed to only pump non-potable water, muddy water, and water containing solids. Pumping flammable liquids, such as gasoline or fuel oils, can result in a fire or explosion, causing serious injury. Pumping sea water, beverages, acids, chemical solutions, or any other liquid that promotes corrosion can damage the pump.

Operate pump on a level surface. If engine is tilted, fuel may spill.

Refuel With Care

Gasoline is extremely flammable, and gasoline vapor can explode. Refuel outdoors, in a well-ventilated area, with the engine stopped and the pump on a level surface. Do not overfill the fuel tank. Never smoke near gasoline, and keep other flames and sparks away. Always store gasoline in an approved container. Make sure that any spilled fuel has been wiped up before starting the engine.

Hot Exhaust

The muffler becomes very hot during operation and remains hot for a while after stopping the engine. Be careful not to touch the muffler while it is hot. Let the engine cool before transporting the pump or storing it indoors.

To prevent fire hazards, keep the pump at least 3 feet (1 meter) away from building walls and other equipment during operation. Do not place flammable objects close to the engine.

Carbon Monoxide Hazards

Exhaust gas contains poisonous carbon monoxide. Avoid inhalation of exhaust gas. Never run the engine in a closed garage or confined area.

PUMP SAFETY

SAFETY LABEL LOCATION

The label shown here contains important safety information. Please read it carefully. This label is considered a permanent part of your pump. So if the label comes off or becomes hard to read, contact your authorized Honda pump dealer for a replacement.

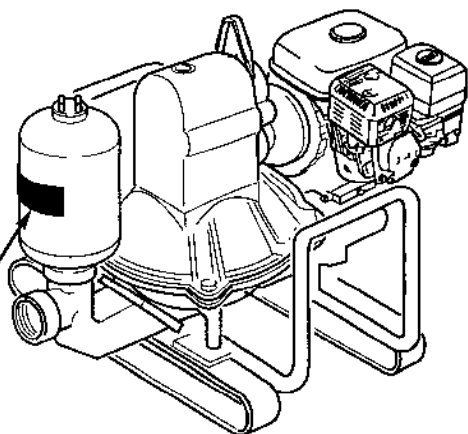

⚠ WARNING

DO NOT PUMP FLAMMABLE LIQUIDS.

Pump can explode and you can be seriously hurt or killed.

Follow the Owner's Manual instructions carefully.

CONTROLS

This chapter shows you the locations of controls and other important parts of your pump, and tells you how the controls work.

COMPONENT IDENTIFICATION	10
DESCRIPTION OF CONTROLS	11
Throttle Lever	11
Choke Lever	11
Fuel Valve Lever	11
Ignition Switch	12
Oil Alert™ System	12
Recoil Starter	12

CONTROLS

COMPONENT IDENTIFICATION

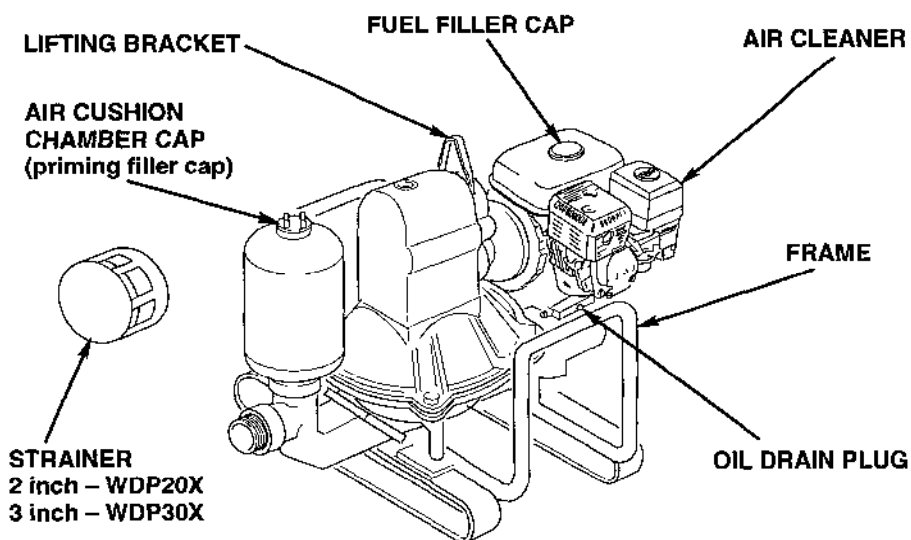
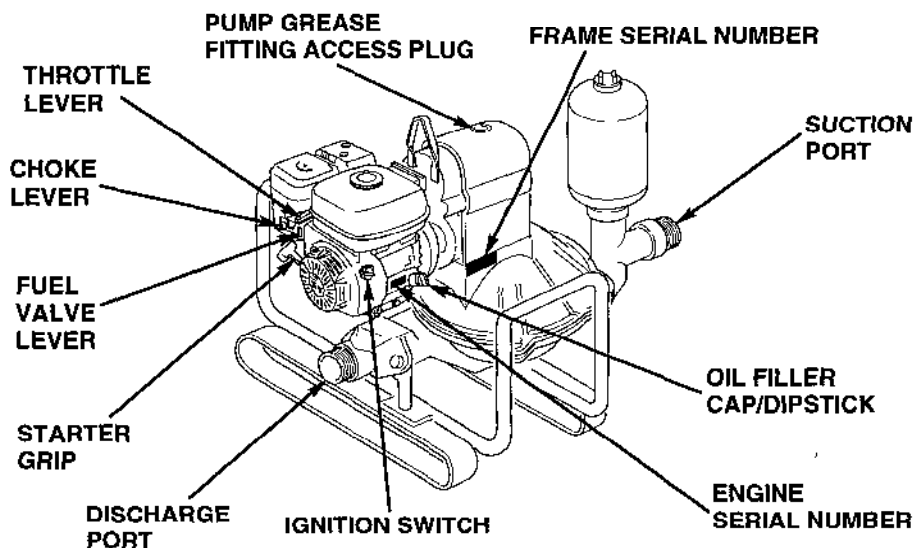

Record the frame and engine serial numbers in the space below. You will need these serial numbers when ordering parts and when making technical or warranty inquiries (see page 66).

Frame serial number: WDP20/30 - _____

Engine serial number: GX120 - _____

DESCRIPTION OF CONTROLS

You will use these controls every time you operate your diaphragm pump.

Throttle Lever

The throttle lever controls the engine speed. Moving the throttle lever fully to the left gives maximum engine speed. Moving the throttle lever fully to the right returns the engine to idle speed.

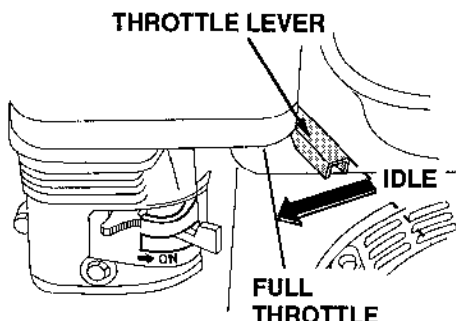

The pump output can be controlled by adjusting the throttle lever to the desired position. At maximum throttle position, the pump will deliver the highest output volume. Moving the throttle toward the idle position will decrease the output volume of the pump.

Choke Lever

The choke is used to provide an enriched mixture when starting a cold engine. Move the choke to the CLOSED position when starting a cold engine. If the engine is warm, leave the choke in the OPEN position.

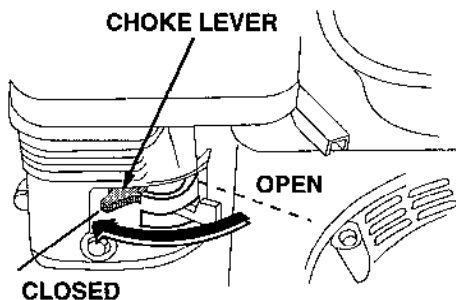

Fuel Valve Lever

The fuel valve lever is used to stop flow of fuel from the fuel tank to the carburetor. The fuel valve lever must be in the ON position to start and operate the engine. Turn the fuel valve lever to the OFF position when the pump is not in use.

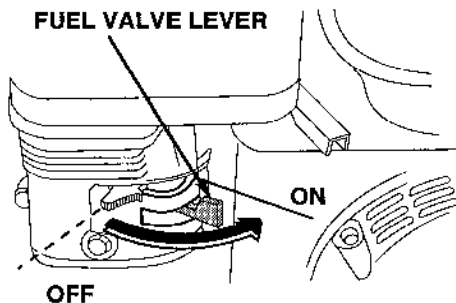

CONTROLS

Ignition Switch

The ignition switch allows the operator to start and stop the engine.

Switch positions:

OFF: To stop the engine.

ON: To start and run the engine.

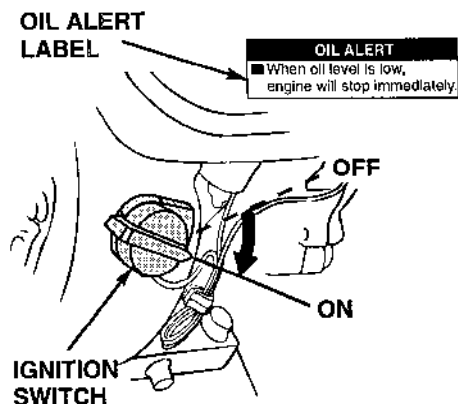

Oil Alert™ System

The Oil Alert system is designed to prevent engine damage caused by an insufficient amount of oil in the crankcase. Before the oil level in the crankcase can fall below a safe limit, the Oil Alert system will automatically shut down the engine (the ignition switch will remain in the ON position).

If the engine stops and will not restart, check the engine oil level (see page 35) before troubleshooting in other areas.

Recoil Starter

To start the engine, pull the recoil starter grip lightly until resistance is felt, then pull briskly.

NOTICE

Do not allow the starter grip to snap back against the engine. Return the starter grip gently to prevent damage to the starter.

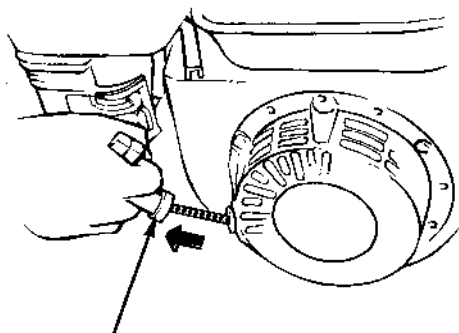

RECOIL STARTER GRIP

BEFORE OPERATION

This chapter tells you how to prepare your pump and yourself before you begin pumping.

ARE YOU READY TO GET STARTED?	14
Knowledge	14
IS YOUR PUMP READY TO GO?	15
Check the General Condition of the Pump	15
Check the Suction and Discharge Hoses	16
Check the Engine	16

BEFORE OPERATION

ARE YOU READY TO GET STARTED?

Your safety is your responsibility. A little time spent in preparation will significantly reduce your risk of injury.

Knowledge

Read and understand this manual. Know what the controls do and how to operate them.

Familiarize yourself with the pump and its operation before you begin pumping. Know what to do in case of emergencies.

Be sure of what you are pumping. This pump is designed to pump only non-potable water, muddy water, and water containing solids.

IS YOUR PUMP READY TO GO?

For your safety, and to maximize the service life of your equipment, it is very important to take a few moments before you operate the pump to check its condition. Be sure to take care of any problem you find, or have your servicing dealer correct it, before you operate the pump.

⚠ WARNING

Improperly maintaining this pump, or failing to correct a problem before operation, could cause a malfunction in which you could be seriously injured.

Always perform a preoperation inspection before each operation, and correct any problem.

Exhaust gas contains poisonous carbon monoxide. Avoid inhalation of exhaust gas. Never run the engine in a closed garage or confined area.

To prevent fire hazards, keep the pump at least 3 feet (1 meter) away from building walls and other equipment during operation. Do not place flammable objects close to the engine.

Before beginning your preoperation checks, be sure the pump is on a level surface and the ignition switch is in the OFF position.

Check the General Condition of the Pump

- Look around and underneath the pump for signs of oil or gasoline leaks.
- Remove any excessive dirt or debris, especially around the engine, muffler, and recoil starter.
- Look for signs of damage.
- Check that all nuts, bolts, screws, hose connectors and clamps are tightened.
- Keep all shields in place while operating the pump.

BEFORE OPERATION

Check the Suction and Discharge Hoses

- Check the general condition of the hoses. Be sure the hoses are in serviceable condition before connecting them to the pump. Remember that the suction hose must be of reinforced construction to prevent hose collapse.
- Check that the sealing washer in the suction hose connector is in good condition (see page 21).
- Check that the hose connectors and clamps are securely installed (see pages 21 & 22).
- Check that the strainer is in good condition and is installed on the suction hose (see page 21).

Check the Engine

- Check the oil level (see page 35). To avoid the inconvenience of an unexpected shutdown by the Oil Alert system, always check the engine oil level before startup.
- Check the air filter (see page 36). A dirty air filter will restrict air flow to the carburetor, reducing engine and pump performance.
- Check the fuel level (see page 33). Starting with a full tank will help to eliminate or reduce operating interruptions for refueling.

Remember, be sure to correct any problem you find, or have your servicing dealer correct it, before you operate the pump.

OPERATION

This chapter tells how to operate your pump safely and effectively.

To safely realize the full potential of this pump, you need a complete understanding of its operation and a certain amount of practice with its controls.

Read this chapter completely before operating the pump. Take time to familiarize yourself with the controls and how they operate. The small amount of time spent in familiarization will reward you with greater efficiency and reduced risk.

SAFE OPERATING PRECAUTIONS	18
PUMP PREPARATION	21
Suction Hose Connection	21
Discharge Hose Connection	22
Pump Priming	22
STARTING THE ENGINE	23
STOPPING THE ENGINE	25
Emergency	25
Normal	25

OPERATION

SAFE OPERATING PRECAUTIONS

To safely realize the full potential of this pump, you need a complete understanding of its operation and a certain amount of practice with its controls.

Before operating the pump for the first time, please review the *IMPORTANT SAFETY INFORMATION* on page 6 and the chapter titled *BEFORE OPERATION*.

For your safety, avoid starting or operating the engine in an enclosed area, such as a garage. Your engine's exhaust contains poisonous carbon monoxide gas which can collect rapidly in an enclosed area and cause illness or death.

Do not pump drinking water. Pump only non-potable water, muddy water, and water containing solids. Pumping flammable liquids, such as gasoline or fuel oils, can result in a fire or explosion, causing serious injury. Pumping sea water, beverages, acids, chemical solutions, or any other liquid that promotes corrosion can damage the pump.

Due to the pump diaphragm reciprocating motion, pump assembly and hoses will move up and down and side-to-side during pumping. This may cause the pump to walk or move around while pumping. Depending on the surface conditions, pump hose length, and other factors it may be necessary to anchor the pump to limit pump movement. During operation, observe pump movement and anchor the pump frame as necessary. To anchor the pump, attach anchored tie down straps to the pump lift handles.

While pumping, the suction hose may move out of the pumping source and the discharge hose may move away from the pumping destination. It may also be necessary to anchor hose ends to prevent hose movement.

If there is no one to monitor the pump during operation, it is advisable to anchor the pump to prevent unexpected movement.

Pump total dynamic discharge head is 50 feet. Total dynamic discharge head includes static discharge head (discharge vertical height) and head loss due to friction. Head loss makes it impractical for the static discharge head to exceed 25 feet. Pumping to a static discharge head greater than 25 feet can damage pump.

This diaphragm pump should never be run with the discharge output shut off or restricted.

NOTICE

Pump case failure may result if the discharge output is shut off or restricted. To avoid pump damage, do not restrict, shut off or momentarily stop the fluid flow from the discharge hose.

A rigid pipe should never be used with a diaphragm pump. Flexible hoses must be attached to the pump. The suction hose must be noncollapsible. Never use hoses that are smaller than the suction or discharge fittings. Example: 2 inch pump requires a 2 inch inside diameter or greater hose and 3 inch pump requires a 3 inch inside diameter or greater hose. Using rigid pipes or hoses that are too small will cause severe damage to the diaphragm pump.

NOTICE

Due to pump movement during operation, connecting a rigid pipe to the pump will cause pump damage. Always use flexible suction and discharge hoses to prevent pump damage.

OPERATION

When water being pumped contains solids, the solids may get lodged under the clappet valves which will prevent the clappet valves from closing completely. To maintain maximum pump performance, the discharge hose should angle upward as it exits the pump.

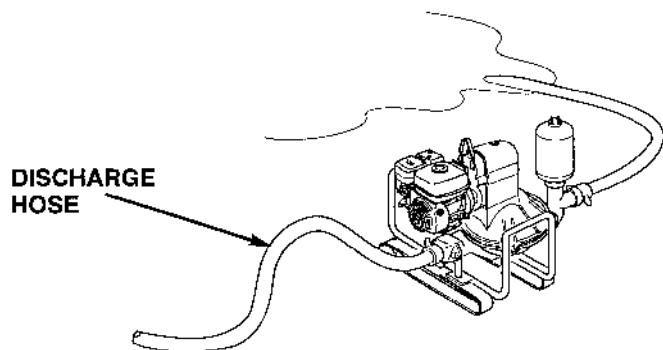

If the discharge hose must run across a roadway, the hose should cross the roadway perpendicular to traffic flow. Also, heavy boards should be placed next to the hose so the motor-vehicle weight does not shut off the discharge as vehicles cross over the hose. Driving over a discharge hose while the pump is running or even possibly when the pump is stopped will most likely cause pump case failure.

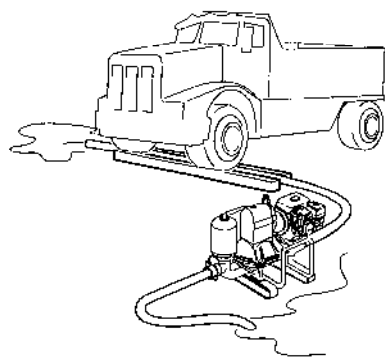

NOTICE

Collapsing the discharge hose will cause pump case and/or diaphragm damage. To prevent pump damage, take the necessary precautions to prevent the discharge hose from getting compressed or collapsed.

During freezing weather, always drain the pump case after use. If water is left in the pump case during freezing weather, the pump case will break.

PUMP PREPARATION

Suction Hose Connection

Use a commercially available hose, hose connector, and hose clamps. Hose must be the same size or larger than the suction port. To prevent hose from collapsing, use a hose that is reinforced with a noncollapsible wall or braided wire construction. Keep pump as close as possible to the pumping liquid. Avoid hose bends and sharp turns. Pump performance is best when the pump is not far above the liquid level and the hose is kept straight. Self-priming time is also proportional to the suction hose length. Using a longer suction hose will increase the self-priming time.

Tighten the hose connector to the suction hose with a hose clamp to prevent air leakage and loss of suction. Verify that the connector sealing washer is installed and in good condition. A loosely connected suction hose will reduce pump performance and self-priming ability.

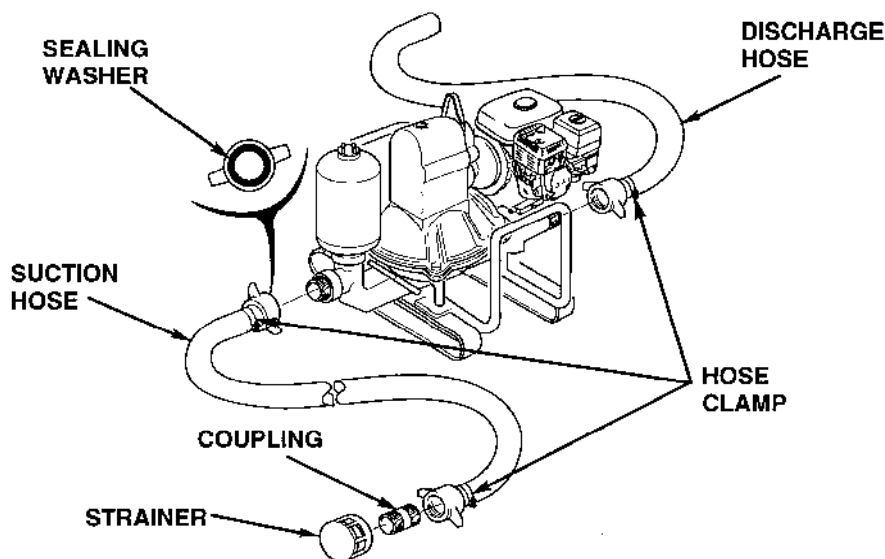

The strainer provided with the pump should be attached to the end of the suction hose as shown.

Always install the strainer on the end of the suction hose before pumping. The strainer will prevent debris from entering the pump that can cause clogging, diaphragm and/or other pump damage.

OPERATION

Discharge Hose Connection

Use a commercially available hose, hose connector, and hose band. A short, large diameter hose will provide lower fluid friction and improve pump efficiency. A long or small diameter hose will increase fluid friction and reduces pump output. Never use a hose size smaller than the discharge port diameter.

NOTICE

If a discharge hose is used that has a smaller inside diameter than the port size, the pump case may be damaged. To avoid pump damage, always use the correct size hose.

Tighten the hose clamp to prevent the hose from disconnecting under high pressure.

Pump Priming

Pump priming is not required if the vertical distance from water to the pump (suction head) is less than 14 feet on WDP20X or 16 feet for a WDP30X. The suction head can be increased to 21 feet for the WDP20X or 24 feet for the WDP30X by priming the pump.

To prime the pump, remove the air cushion chamber cap. Grasp the suction hose next to the suction fitting and lift the hose about 1 foot off the ground. Pour about 1 gallon of water into the pump case through the air cushion chamber. Lifting the suction hose will help to ensure the water goes into the pump housing and not out the suction hose. Lay the hose back on the ground, and reinstall the air cushion chamber cap.

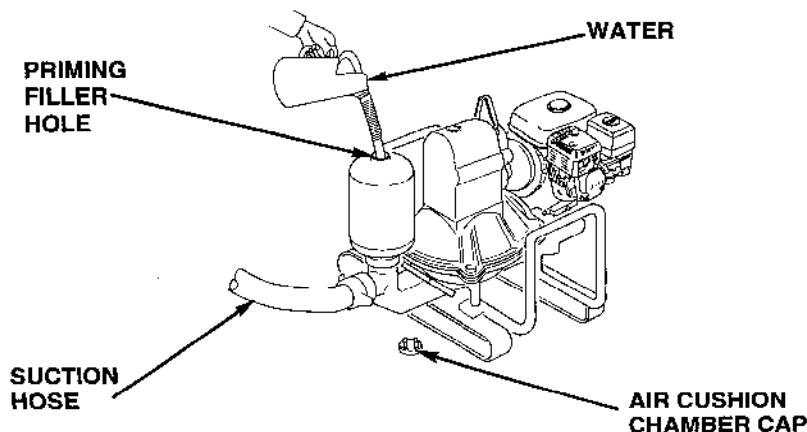

STARTING THE ENGINE

1. Turn the fuel valve to the ON position.

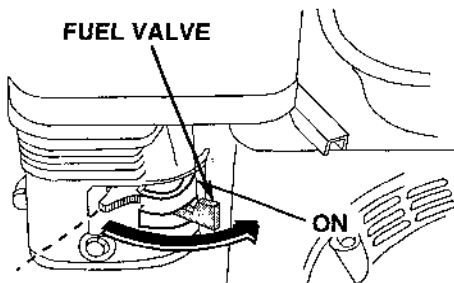

2. Move the choke lever to the CLOSED position.

Do not use the choke if the engine is warm or the ambient temperature is high.

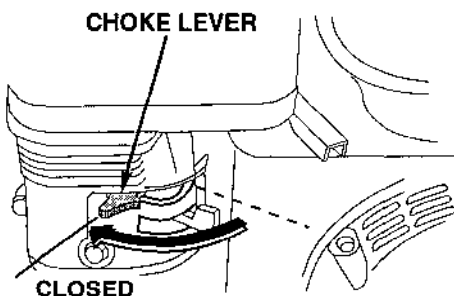

3. Turn the ignition switch to the ON position.

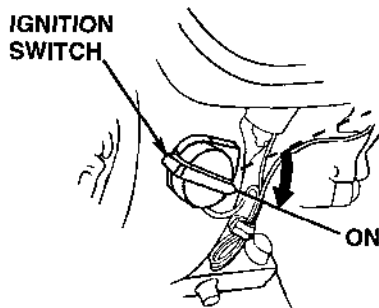

4. Move the throttle lever slightly to the left.

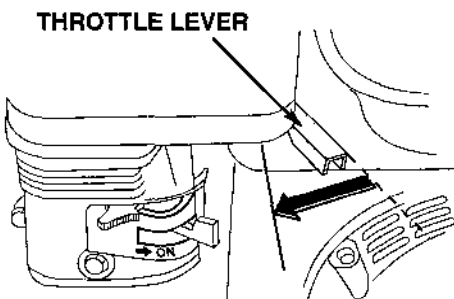

OPERATION

5. Pull the starter grip lightly until resistance is felt, then pull it briskly.

NOTICE

Return the starter grip slowly back to the engine to prevent damage to the starter.

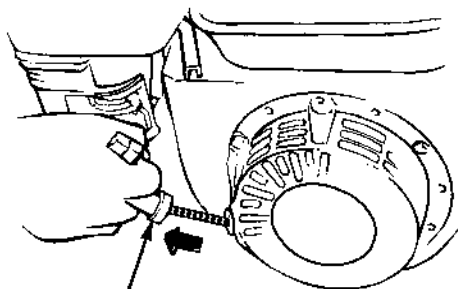

STARTER GRIP

6. As the engine warms up, gradually move the choke lever to the OPEN position.

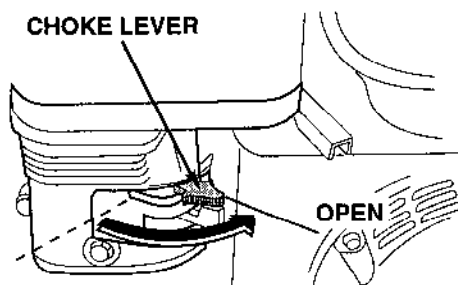

CHOKE LEVER

7. Set the throttle at the desired speed to produce the best pumping conditions.

The pump output can be controlled by adjusting the throttle lever to the desired position. At FULL throttle position, the pump will deliver the highest output volume. Moving the throttle toward the IDLE position will decrease the output volume of the pump.

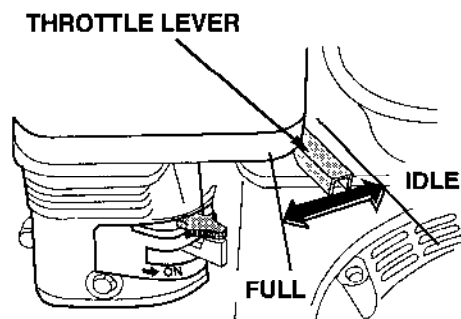

THROTTLE LEVER

STOPPING THE ENGINE

Emergency

To stop the engine in an emergency, turn the ignition switch to the OFF position.

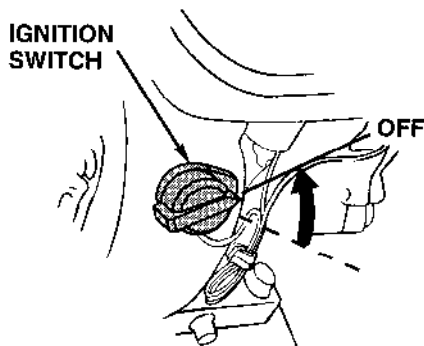

Normal

1. Move the throttle lever fully to the right to the IDLE position.
2. Turn the ignition switch to the OFF position.

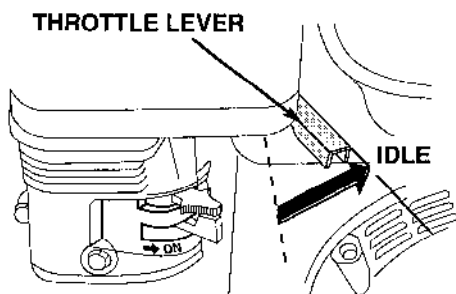

3. Turn the fuel valve to the OFF position.

4. If the pump is not going to be used again for the rest of the day, or is going to be stored for a long period of time, refer to page 55 for procedures on properly storing your pump.

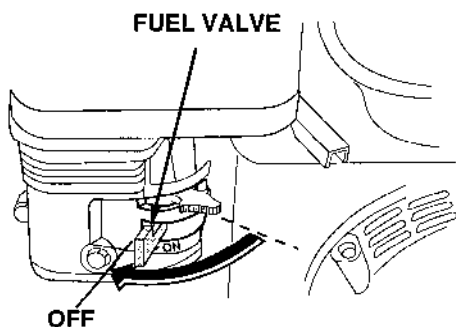

After each use, drain the pump chamber and flush with fresh water.

TRANSPORTING

This chapter explains how to load and carry your pump safely.

BEFORE LOADING	28
LOADING AND UNLOADING.	28

TRANSPORTING

BEFORE LOADING

When transporting the pump, be sure to keep it upright. If the pump is tilted or overturned, fuel may spill from the tank, which can result in a fire hazard.

Allow the engine to cool before transporting the pump.

1. Turn the ignition switch to the OFF position.

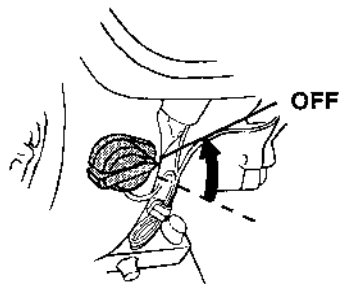

2. Turn the fuel valve to the OFF position.

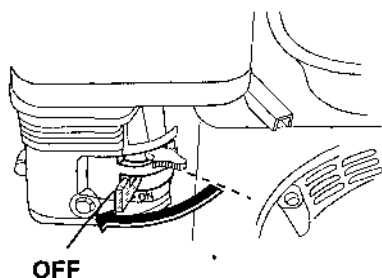

3. Drain the pump chamber (refer to page 43).

LOADING AND UNLOADING

Have two people lift the pump or use a hoist connected to the lifting bracket to load the pump on and off the transport vehicle.

Position the pump so it is level on the transport vehicle. Tie the pump down with rope or straps. Keep the tie-down rope or straps away from the controls and carburetor.

MAINTENANCE

This chapter explains when and how to perform routine inspection, service, and adjustments for do-it-yourself maintenance. More difficult maintenance tasks should be done by your dealer. Your dealer is best equipped and staffed to provide the level of service and safety you and your pump deserve.

THE IMPORTANCE OF MAINTENANCE	30
MAINTENANCE SAFETY	31
Safety Precautions	31
MAINTENANCE SCHEDULE	32
FUEL	33
ENGINE MAINTENANCE	34
Engine Oil Change	34
Engine Oil Recommendations	35
Air Cleaner Service	36
Spark Plug Service	38
Carburetor Adjustment	40
Carburetor Modification for High Altitude Operation	40
Fuel Recommendations	41
Sediment Cup Cleaning	41
Fuel Filter/Fuel Line	42
PUMP SERVICE	43
Pump Chamber Flushing	43
Pump Hoses and Strainer	43
Grease Pump Connecting Rod	44
Pump Gear Box Oil Change	44
Pump Gear Box Oil Check	44
Pump Clappet Valves	45
Pump Diaphragm	47
Disassembly	47
Reassembly	49

MAINTENANCE

THE IMPORTANCE OF MAINTENANCE

Good maintenance is essential for safe, economical and trouble-free operation. It will also help reduce pollution.

⚠ WARNING

Improper maintenance, or failure to correct a problem before operation, can cause a malfunction in which you can be seriously hurt or killed.

Always follow the inspection and maintenance recommendations and schedules in this owner's manual.

To help you properly care for your pump, the following pages include a maintenance schedule, routine inspection procedures, and simple maintenance procedures using basic hand tools. Other service tasks that are more difficult, or require special tools, are best handled by professionals and are normally performed by a Honda technician or other qualified mechanic.

The maintenance schedule applies to normal operating conditions. If you operate your pump under severe conditions, such as sustained high-load or high-temperature operation, or use in unusually wet or dusty conditions, consult your servicing dealer for recommendations applicable to your individual needs and use.

Remember that an authorized Honda servicing dealer knows your pump best and is fully equipped to maintain and repair it.

To ensure the best quality and reliability, use only new genuine Honda parts or their equivalents for repair and replacement.

Maintenance, replacement, or repair of the emission control devices and systems may be performed by any engine repair establishment or individual, using parts that are "certified" to EPA standards.

MAINTENANCE SAFETY

Some of the most important safety precautions follow. However, we cannot warn you of every conceivable hazard that can arise in performing maintenance. Only you can decide whether or not you should perform a given task.

⚠ WARNING

Failure to properly follow maintenance instructions and precautions can cause you to be seriously hurt or killed.

Always follow the procedures and precautions in this owner's manual.

Safety Precautions

- Make sure the engine is off before you begin any maintenance or repairs. This will eliminate several potential hazards:
 - **Carbon monoxide poisoning from engine exhaust.**
Be sure there is adequate ventilation whenever you operate the engine.
 - **Burns from hot parts.**
Let the engine and exhaust system cool before touching.
 - **Injury from moving parts.**
Do not run the engine unless instructed to do so.
- Read the instructions before you begin, and make sure you have the tools and skills required.
- To reduce the possibility of fire or explosion, be careful when working around gasoline. Use only a nonflammable solvent, not gasoline, to clean parts. Keep cigarettes, sparks and flames away from all fuel related parts.

MAINTENANCE

MAINTENANCE SCHEDULE

ITEM	REGULAR SERVICE PERIOD (4) Perform at every indicated month or operating hour interval, whichever comes first.	Before Each Use	After Each Use	First month or 20 hours	Every 3 months or 50 hours	Every 6 months or 100 hours	Every year or 300 hours	Refer to page
		O	O	O	O	O	O	
• Engine oil	Check level	O						35
	Change			O		O		34
• Air Cleaner	Check	O						36
	Clean				O(1)			
	Replace						O*(1)	
• Sediment cup	Clean				O			41
• Spark plug	Clean-Adjust					O		38
	Replace						O	
Spark arrester (optional equipment)	Clean					O(3)		70
• Idle speed	Check-Adjust						O(2)	40
• Valve clearance	Check-Adjust						O(2)	-
• Fuel tank and filter	Clean						O(2)	42
Pump chamber	Flush		O					43
Pump hoses and strainer	Check	O						43
Pump connecting rod bearing	Grease			O	O			44
	Check level				O			44
Pump gearbox oil	Change						O	44
	Inspect						O	45
Pump diaphragm	Inspect						O	47
Nuts and bolts	Check torque						O	-
• Fuel line	Check						Every 2 years (2) (Replace if necessary)	42

• Emission related items.

* Replace the paper element only.

(1) Service more frequently when used in dusty areas. Replace if damaged.

(2) These items should be serviced by an authorized Honda water pump dealer, unless the owner has the proper tools and is mechanically proficient. See the Honda WDP20X • WDP30X pump shop manual.

(3) The spark arrester is an optional part and does not come standard.

(4) For professional commercial use, log hours of operation to determine proper maintenance intervals.

FUEL

Fuel tank capacity: 0.66 US gal (2.5 ℓ)

Refuel in a well-ventilated area with the engine stopped. If the engine has been running, allow it to cool. Refer to page 41 for fuel recommendations and page 67 for information about oxygenated fuels.

Never refuel the pump inside a building where gasoline fumes may reach flames or sparks. Keep gasoline away from appliance pilot lights, barbecues, electric appliances, power tools, etc.

Spilled fuel is not only a fire hazard, it causes environmental damage. Wipe up spills immediately.

⚠ WARNING

Gasoline is highly flammable and explosive.

You can be burned or seriously injured when handling fuel.

- Stop the engine and keep heat, sparks, and flame away.
- Handle fuel only outdoors.
- Wipe up spills immediately.

1. Remove the filler cap and check the fuel level.
2. Refill the tank if the fuel level is low. Do not fill above the shoulder of the fuel filler neck.
3. After refueling, make sure the tank filler cap is closed properly and securely.

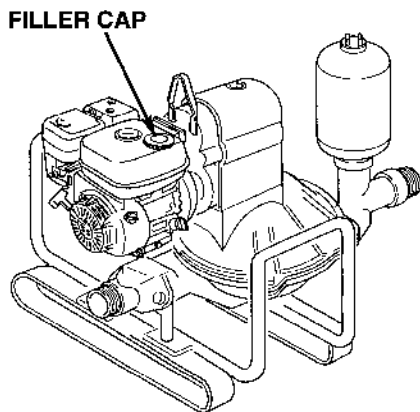

MAINTENANCE

ENGINE MAINTENANCE

Engine Oil Change

Drain the oil while the engine is warm. Warm oil drains quickly and completely.

1. Remove the oil filler cap, drain bolt and sealing washer. Drain the oil into a suitable container.

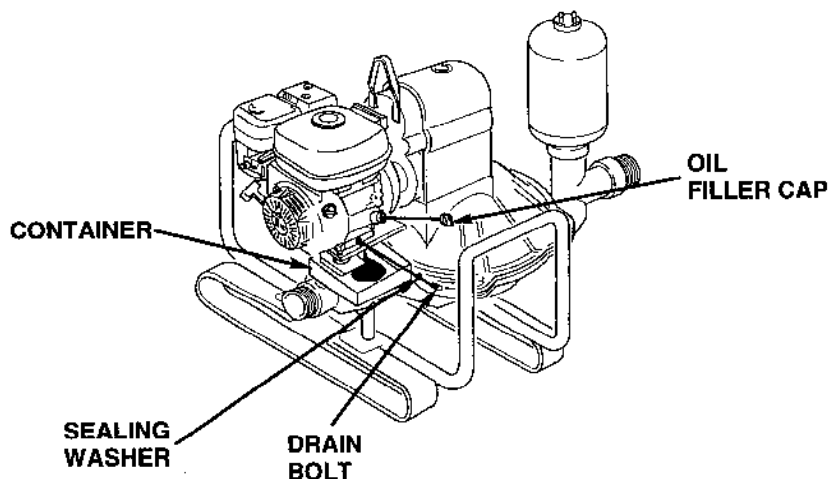

2. Reinstall the drain bolt and sealing washer. Tighten the plug securely.

NOTICE

Improper disposal of engine oil can be harmful to the environment. If you change your own oil, please dispose of the used oil properly. Put it in a sealed container, and take it to a recycling center. Do not discard it in a trash bin or dump it on the ground.

3. Fill with the recommended oil to the top of the oil filler neck (see page 35).

Engine oil capacity: 0.6 US qt (0.6 ℓ)

NOTICE

Using nondetergent oil can shorten the engine's service life, and using 2-stroke oil can damage the engine.

4. Screw in the oil filler cap/dipstick securely.

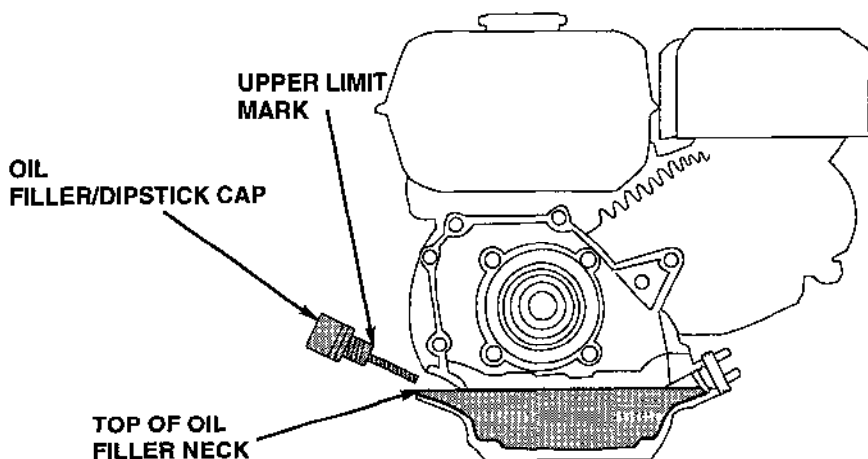

Engine Oil Recommendations

Oil is a major factor affecting performance and service life. Use 4-stroke automotive detergent oil.

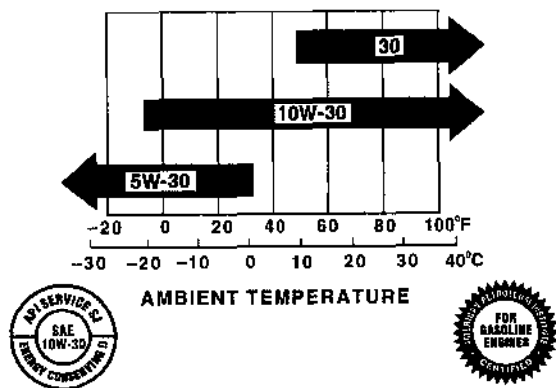

SAE 10W-30 is recommended for general use. Other viscosities shown in the chart may be used when the average temperature in your area is within the recommended range.

The SAE oil viscosity and service classification are in the API label on the oil container. Honda recommends that you use API SERVICE category SH or SJ oil with the ILSAC "starburst" certification mark displayed on the container.

MAINTENANCE

Air Cleaner Service

A dirty air filter will restrict air flow to the carburetor, reducing engine performance. If you operate the pump in very dusty areas, clean the air filter more often than specified in the MAINTENANCE SCHEDULE.

NOTICE

Operating the engine without an air filter, or with a damaged air filter, will allow dirt to enter the engine, causing rapid engine wear. This type of damage is not covered by the Distributor's Limited Warranty.

1. Unscrew the outer wing nut and remove the air cleaner cover.
2. Remove the inner wing nut and both air filter elements.
3. Separate both air filter elements and carefully check them for holes or tears and replace as necessary.

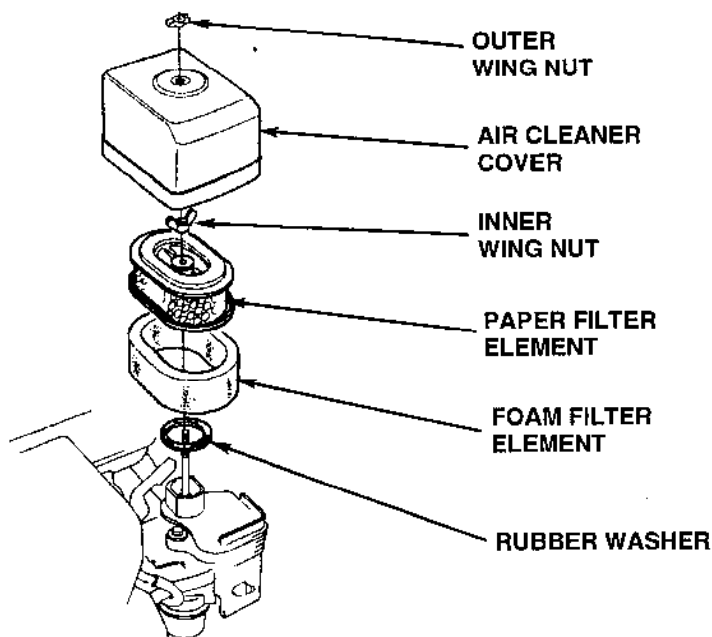

4. Clean the filters.

Paper element: Tap the element lightly several times on a hard surface to remove excess dirt, or blow compressed air [not exceeding 30 psi (207 kPa)] through the filter element from the inside out. Never try to brush the dirt off; brushing will force dirt into the paper fibers. Replace the paper element if it is excessively dirty or damaged.

Foam element cleaning: Wash the element in a solution of household detergent and warm water, then rinse thoroughly, or wash in nonflammable solvent. Allow element to dry thoroughly. Soak the element in clean engine oil and squeeze out the excess oil.

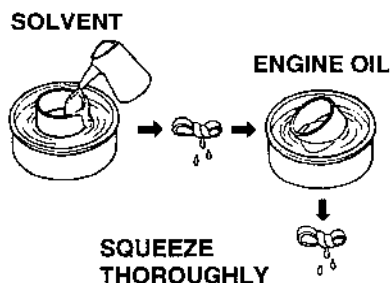

NOTICE

Excess oil will restrict air flow through the foam filter element and may transfer to the paper filter element, soaking and clogging it.

5. Wipe dirt from the inside of the air cleaner housing and cover. Be careful to prevent dirt from entering the air duct that leads to the carburetor.

6. Install the foam element over the paper element, and install the assembled air filter. Secure the air filter with the inner wing nut. Make sure the rubber washer is in place under the filter elements.

7. Install the air cleaner cover, and secure with the outer wing nut.

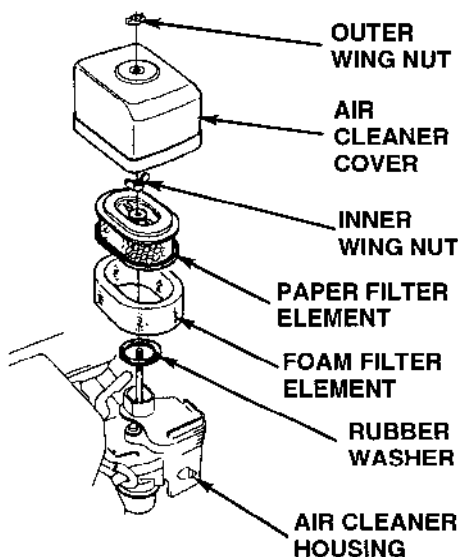

MAINTENANCE

Spark Plug Service

Recommended spark plugs: NGK – BPR6ES
DENSO – W20EPR-U

NOTICE

Spark plugs of the wrong size or incorrect heat range can cause engine damage.

For good performance, the spark plug must be properly gapped and free of deposits.

Allow the engine to cool before servicing the spark plug.

1. Disconnect the spark plug cap and remove any dirt from around the spark plug area.
2. Use a 13/16 in (21 mm) spark plug wrench to remove the spark plug.
3. Visually inspect the spark plug. Discard it if the insulator is cracked or chipped. Clean the spark plug with a wire brush if it is to be reused.
4. Measure the plug gap with a suitable gauge.

Correct as necessary by carefully bending the side electrode.

Plug gap: 0.028 ~ 0.031 in
(0.70 ~ 0.80 mm)

SPARK PLUG WRENCH

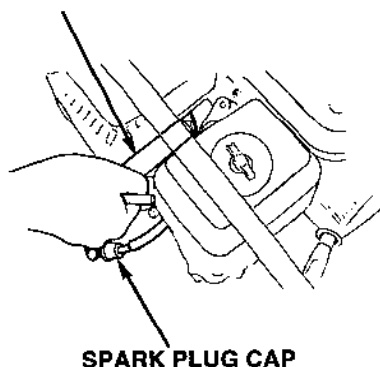

0.028 ~ 0.031 in
(0.70 ~ 0.80 mm)

SEALING WASHER

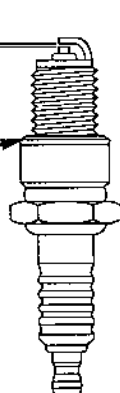

5. Check that the spark plug washer is in good condition, and thread the spark plug in by hand to prevent cross-threading.
6. After the spark plug is seated, tighten with a spark plug wrench to compress the washer.

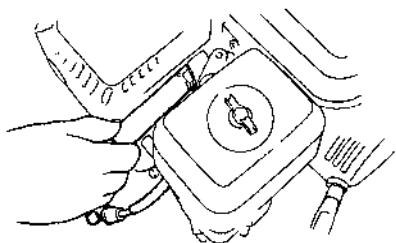

If installing a new spark plug, tighten 1/2 turn after the spark plug seats to compress the washer.

If reinstalling a used spark plug, tighten 1/8 - 1/4 turn after the spark plug seats to compress the washer.

NOTICE

A loose spark plug can overheat and damage the engine. Overtightening the spark plug can damage the threads in the cylinder head.

7. Reconnect the spark plug cap.

MAINTENANCE

Carburetor Adjustment

1. Start the engine outdoors, and let it warm up to normal operating temperature.
2. Move the throttle lever to the slowest position.
3. Using a screwdriver, turn the throttle stop screw to obtain the standard idle speed.

Standard Idle Speed:

1,400⁺²⁰⁰
-150 rpm

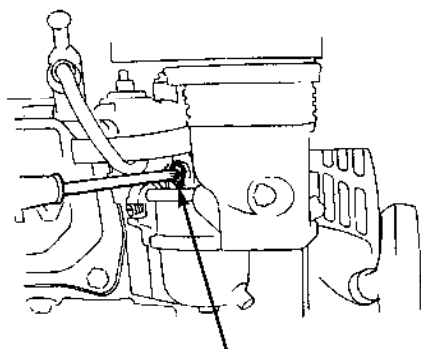

THROTTLE STOP SCREW

Carburetor Modification for High Altitude Operation

At high altitude, the standard carburetor air fuel mixture will be too rich. Performance will decrease, and fuel consumption will increase. A very rich mixture will also foul the spark plug and cause hard starting.

High altitude performance can be improved by specific modifications to the carburetor. If you always operate the pump above 5,000 feet (1,500 meters), have an authorized Honda servicing dealer perform this carburetor modification.

Even with carburetor modification, engine horsepower will decrease about 3.5% for each 1,000-foot (300-meter) increase in altitude. The effect of altitude on horsepower will be greater than this if no carburetor modification is made.

NOTICE

When the carburetor is modified for high altitude operation, the air fuel mixture will be too lean for low altitude use. Operation at altitudes below 5,000 feet (1,500 meters) with a modified carburetor may cause the engine to overheat and result in serious engine damage. For use at low altitudes, have an authorized Honda servicing dealer return the carburetor to original factory specifications.

Fuel Recommendations

Use unleaded gasoline with a pump octane rating of 86 or higher.

This engine is certified to operate on unleaded gasoline. Unleaded gasoline produces fewer engine and spark plug deposits and extends exhaust system life.

Never use stale or contaminated gasoline or oil/gasoline mixture. Avoid getting dirt or water in the fuel tank.

Occasionally you may hear light "spark knock" or "pinging" (metallic rapping noise) while operating under heavy loads. This is no cause for concern.

If spark knock or pinging occurs at a steady engine speed, under normal load, change brands of gasoline. If spark knock or pinging persists, see an authorized Honda servicing dealer.

NOTICE

Running the engine with persistent spark knock or pinging can cause engine damage.

Running the engine with persistent spark knock or pinging is misuse, and the Distributor's Limited Warranty does not cover parts damaged by misuse.

For oxygenated fuel information refer to page 67.

Sediment Cup Cleaning

1. Turn the fuel valve to the OFF position.
2. Remove the sediment cup and O-ring and wash them in nonflammable solvent. Dry them thoroughly.
3. Install the O-ring and sediment cup and tighten securely.
4. Turn the fuel valve to the ON position and check for leaks.

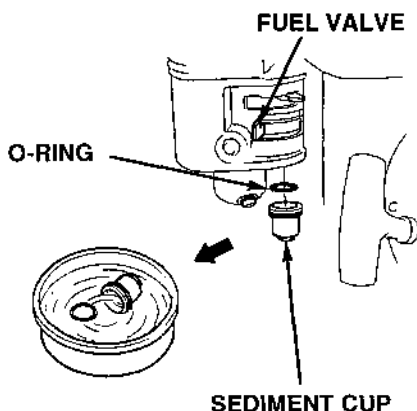

MAINTENANCE

Fuel Filter/Fuel Line

1. Turn the fuel valve to the OFF position.
2. Remove the carburetor drain screw and gasket.
3. Turn the fuel valve to the ON position and drain the fuel into a suitable container. Disconnect the fuel line at the carburetor. Remove the two 6 mm nuts and one 6 x 25 mm bolt securing the fuel tank. Remove the fuel tank.
4. Disconnect the fuel line, and unscrew the fuel filter from the tank. Inspect the fuel line and replace if cracked or worn.

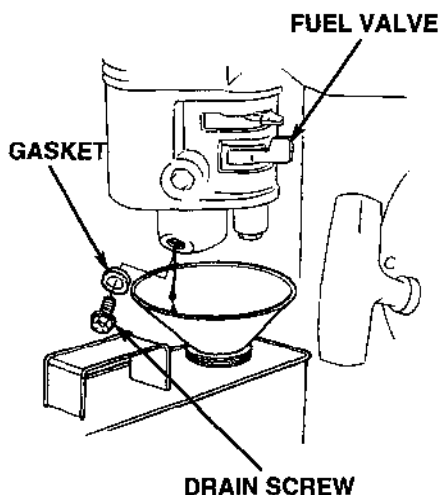

5. Clean the filter with nonflammable solvent, and check that the filter screen is not damaged. Replace as necessary.
6. Clean the inside of the tank with nonflammable solvent and dry thoroughly.
7. Place the O-ring on the filter and install the filter in the tank. Tighten the filter to the specified torque.

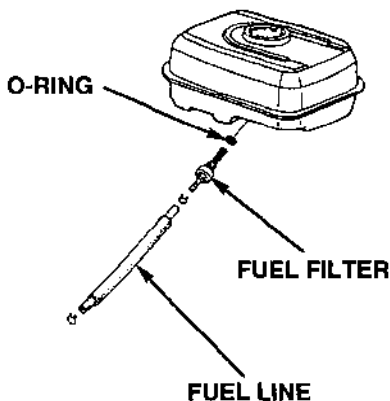

Torque: 17 in-lb
(20 kg-cm, 2 N·m)

8. Install the fuel line on the fuel filter, and install the tank on the engine.
9. After the tank is installed, add fuel and check for leaks.

PUMP SERVICE

Pump Chamber Flushing

With the engine stopped, the pump case should be flushed after each use to prevent sediment from building up in the case.

1. Disconnect the suction and discharge hoses.
2. Insert a garden hose into the suction side of the pump. Turn on the water and thoroughly flush sediment out the discharge side.

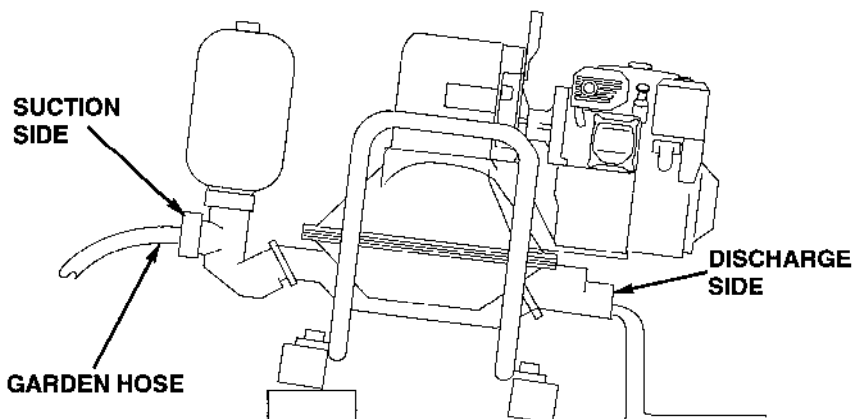

3. After flushing, lift the suction side of the pump and allow water to drain out the discharge side.

Pump Hoses and Strainer

Make sure both hoses are not torn or cracked. It is especially important that there are no tears in the suction hose. Tears or air leaks on the suction side will prevent the pump from priming properly.

Inspect the suction hose sealing washer to make sure it is in good condition.

Also, inspect the strainer to be sure it is not plugged or damaged.

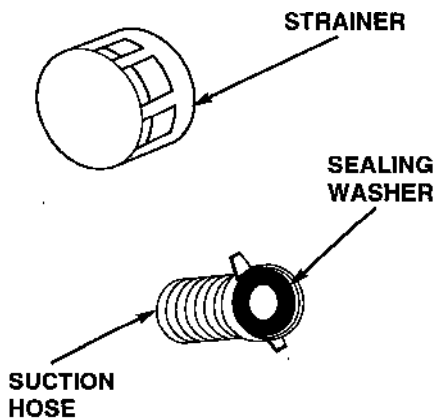

MAINTENANCE

Grease Pump Connecting Rod

1. Remove plastic access plug.
2. Disconnect spark plug cap and pull recoil starter until grease fitting is below access opening.
3. Wipe grease fitting clean to prevent dirt from getting into bearing. Using a manual grease gun, pump one or two strokes of NLGI #2 general purpose grease into bearing.
4. Reinstall access plug securely.

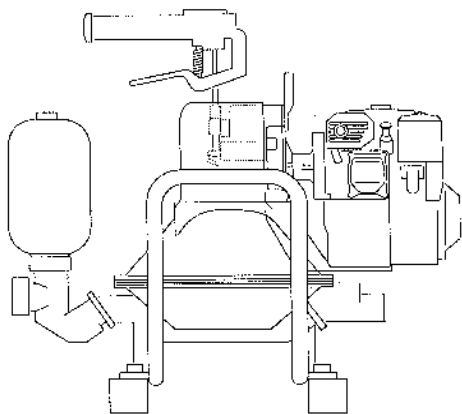

Pump Gear Box Oil Change

1. Run engine for 10 minutes to warm up gear box oil. Warm oil drains quickly and completely.
2. Shut off engine, remove the drain bolt, and drain the gear oil from the gear box.
3. Replace drain bolt washer and reinstall the drain bolt. Fill gear box to bottom of the filler bolt. Dispose of used oil properly (see page 34).

Gear box oil:

Capacity – 0.8 qt (0.8 ℓ)

Type – SAE 80W/90 GL5 gear oil

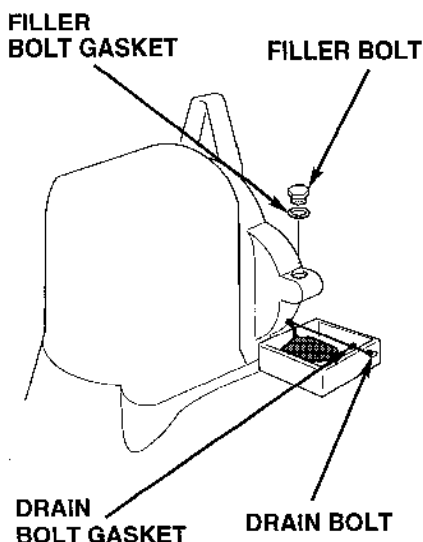

NOTICE

Avoid getting gear oil on diaphragm. Drain oil into a drain pan to prevent oil from running down pump case onto diaphragm. If gear oil comes in contact with the diaphragm, diaphragm will be damaged.

Pump Gear Box Oil Check

With the pump on a level surface, remove the filler bolt. The oil level should be just below the filler bolt hole.

Pump Clappet Valves

1. Disconnect spark plug cap from the spark plug, refer to page 38.
2. Turn the fuel valve lever to the off position, refer to page 11.
3. Flush pump chamber, refer to page 43.
4. Lift suction side of pump and allow all water to drain out the discharge fitting.
5. Use a 19 mm wrench and remove the nuts and flat washers from both the suction and discharge ports.
6. Remove both ports.
7. The clappet valves are directional, so when removing the valves note of the water flow direction.

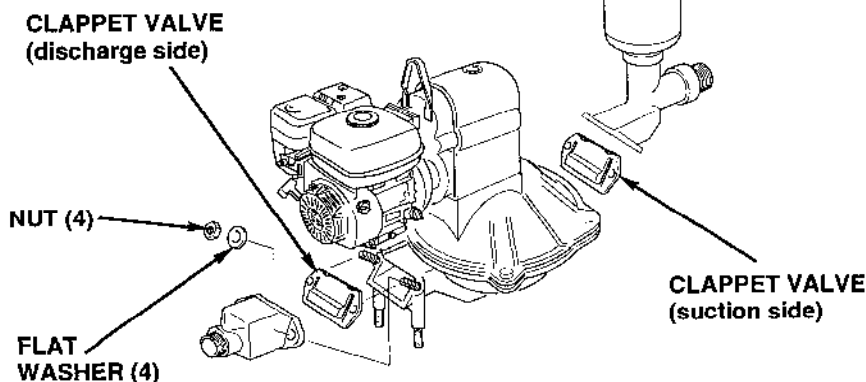
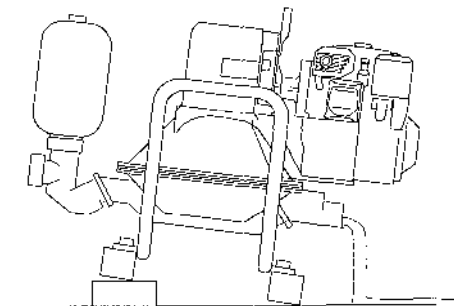

8. Inspect ports, case sealing surfaces, and clappets for damage. If clappets are worn, torn or damaged, replace them. If the case sealing surface is damaged and cannot be cleaned, an optional wear plate is available from your Honda water pump dealer.

MAINTENANCE

9. Install the clappet valves over the studs. On the discharge side, the flat side of the valve should face the housing. On the suction side, the flat side of the valve should face the port.

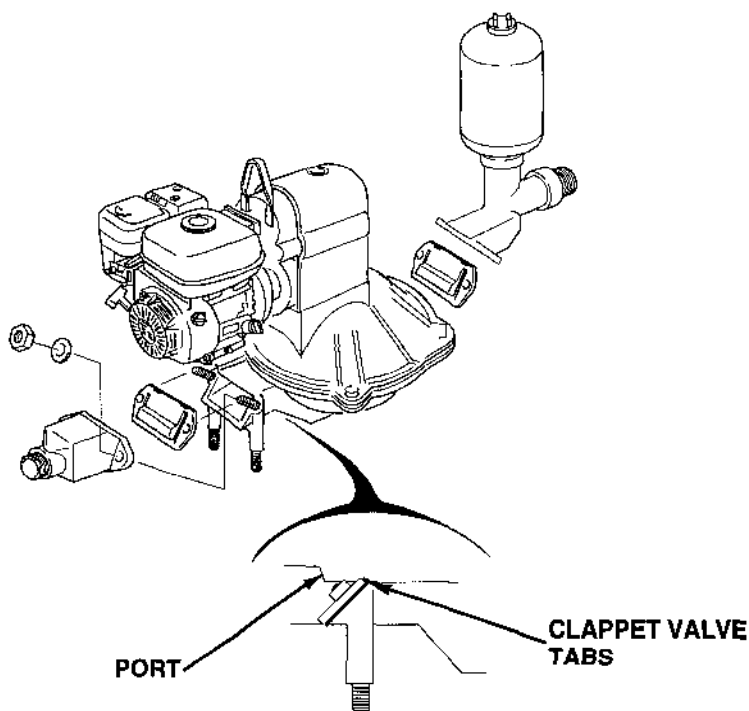

10. Install both ports making sure all clappet valve tabs are positioned correctly.
11. Apply several drops of Hondalock 2 or equivalent thread lock to stud threads. Handtighten nuts then torque evenly to 20 ft-lb (27 N·m, 2.8 kg·m).
12. After tightening nuts, insert a screwdriver into each port and check clappet valve operation. Clappets should operate freely and should seal when released. If a clappet does not operate properly, reinstall clappet and recheck.
13. Run pump and check for leaks.

Pump Diaphragm

Disassembly

1. Disconnect spark plug cap from the spark plug, refer to page 38.
2. Drain the fuel tank, refer to page 42 for fuel tank draining.
3. Flush pump chamber, refer to page 43.
4. Lift suction side of pump and allow all water to drain out discharge fitting.
5. Remove hardware securing pump handle and springs.

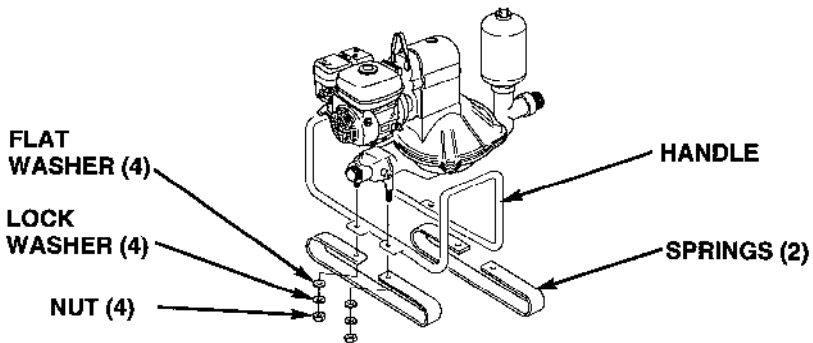
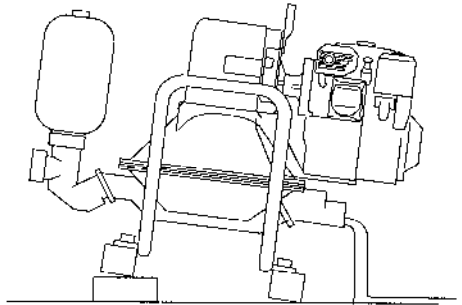

6. Connect a hoist to the lifting bracket or have an assistant help lift pump off handle and onto a workbench. Position pump on a workbench as shown.

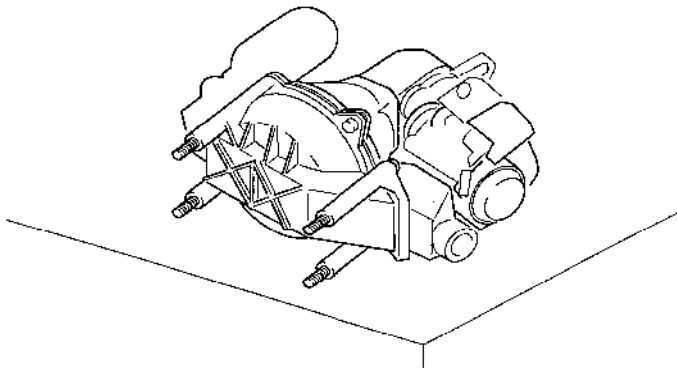

MAINTENANCE

7. Remove connecting rod plastic cover.
8. Use a 17 mm wrench and remove the bolt securing the connecting rod to the crank arm. Wipe the rod surface clean and use a felt tip marker to mark the outside of the connecting rod for reassembly.

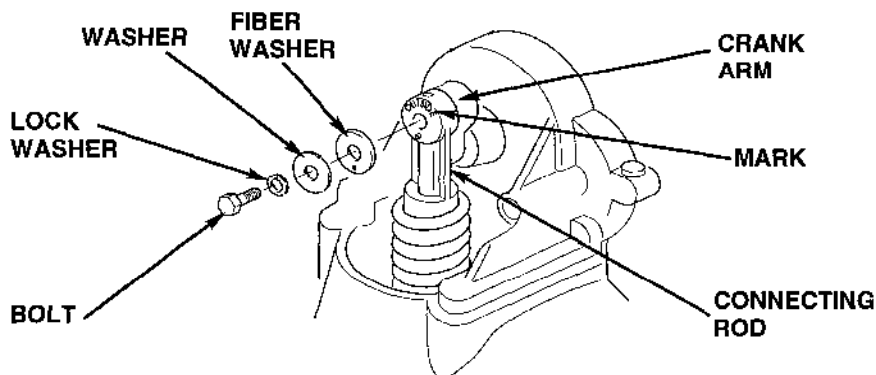

9. Pull the recoil starter to rotate the connecting rod to the down position.
10. Remove bolts and the lower pump case using a 19 mm wrench. Remove the connecting rod and diaphragm assembly.

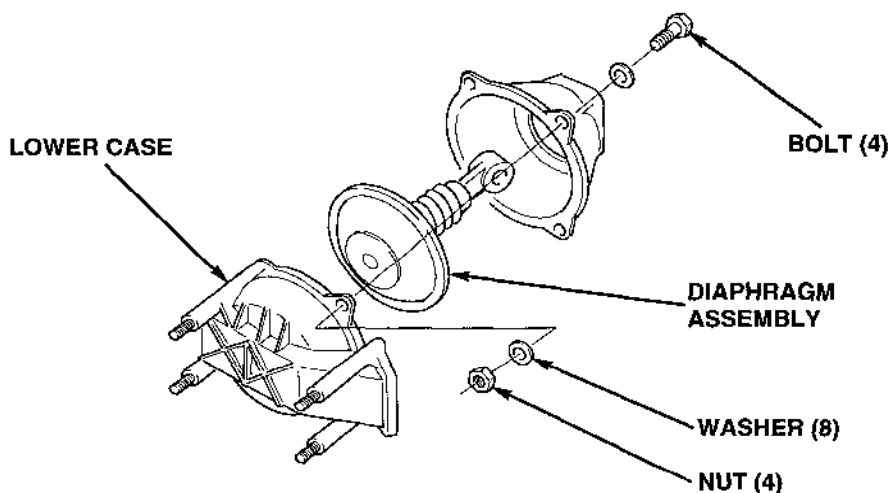

10. If the diaphragm is to be reused, mark diaphragm and diaphragm locking flanges. With a 19 mm wrench, remove the four nuts securing the connecting rod to the lower flange. Remove the diaphragm. For reassembly, note shoulder on top of diaphragm.

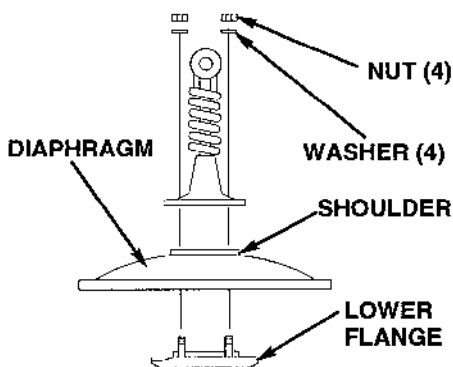

Reassembly

During reassembly, note the following:

- Apply several drops of Hondalock 2 or equivalent thread lock to bolt threads
- To prevent pump case and/or diaphragm damage, follow torque sequence shown below

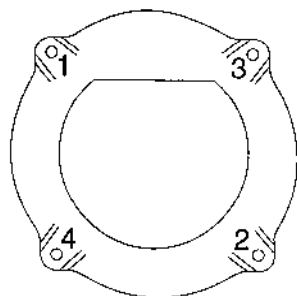

Torque: Start in one corner increasing the amount or torque 1/8th to 1/4 turn each time around until the specified torque is achieved

Pump case bolts 35 ft-lb (47 N·m, 4.8 kg-m)

Diaphragm flange nuts 35 ft-lb (47 N·m, 4.8 kg-m)

Connecting rod bolt 40 ft-lb (54 N·m, 5.5 kg-m)

NOTICE

The pump case and/or diaphragm may become damaged if the torque sequence is not followed.

MAINTENANCE

1. Position diaphragm between connecting rod flange and lower flange then install nuts and washers. Note diaphragm shoulder on top. See page 49 for tightening torque.

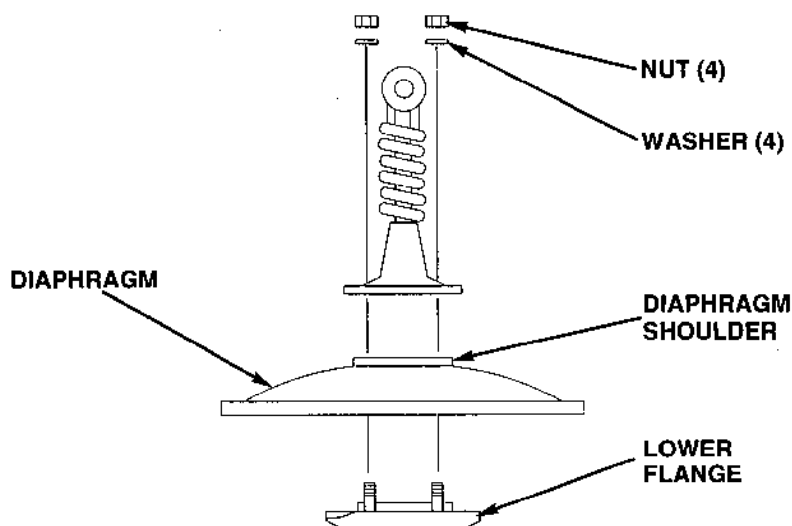

2. Apply NLGI #2 general purpose grease to connecting rod bearing.
3. Rotate crank arm to bottom by pulling the recoil starter. Install diaphragm and connecting rod into pump case then install connecting rod with mark made during disassembly facing out.
4. Install connecting rod with hardware shown below and torque connecting rod bolt to 40 ft-lb (54 N·m, 5.5 kg-m).

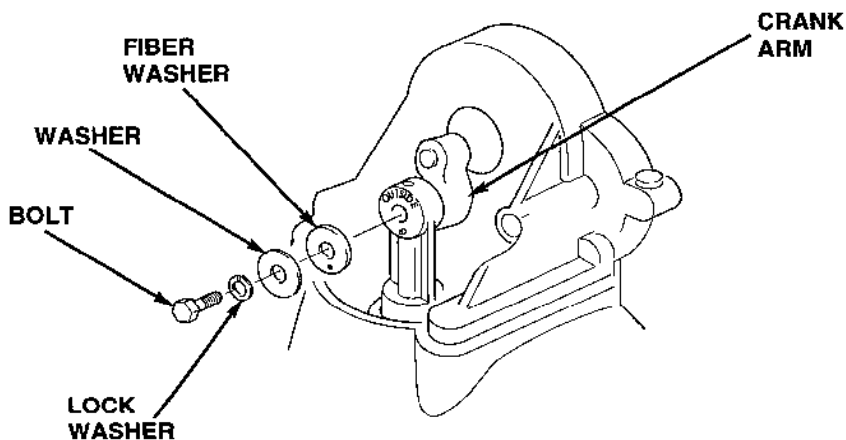

5. Pull recoil starter slowly until diaphragm pulls up against upper case stops.

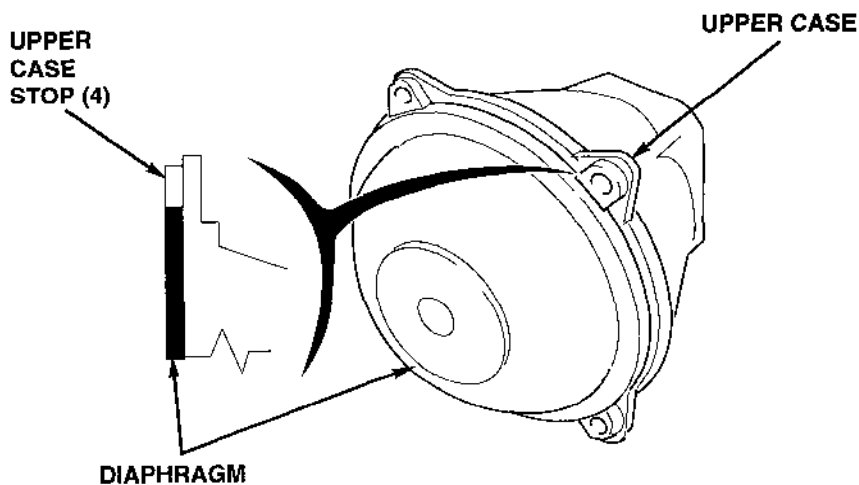

Crank arm should be approximately at the angle shown below.

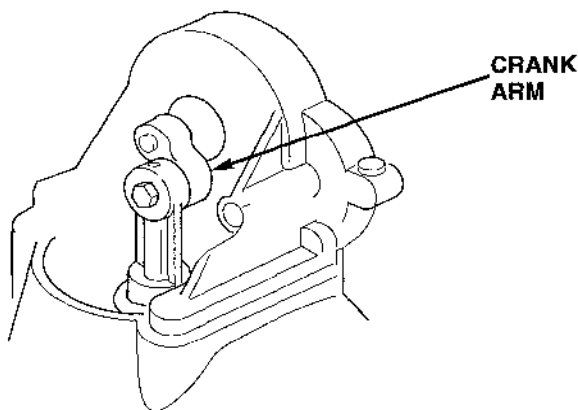

6. Install lower case making sure the diaphragm is centered and not pinched between the case stops. Tighten hardware following torque procedure on page 49.
7. If removed, install clappet valves. Refer to page 45.
8. Install pump handle and springs.
9. Check gear box oil level and fill if necessary. Refer to page 44.
10. Run and test pump for correct operation.

TROUBLESHOOTING

This chapter tells you what to check for if you encounter problems with your pump.

ENGINE WILL NOT START	54
Fuel	54
Spark Plug	54
PUMP WILL NOT PUMP	54

TROUBLESHOOTING

ENGINE WILL NOT START

Fuel

1. Is there enough fuel in the fuel tank? (page 33).
2. Is the fuel valve ON?
3. Is the choke lever in the closed position for cold engine or open position for a warm engine?

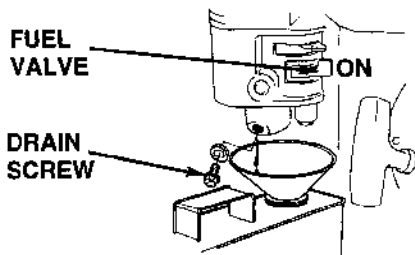

4. Is fuel reaching the carburetor? To check, place a suitable container under the float bowl and remove the drain screw. Turn fuel valve ON. Fuel should flow out freely.

Spark Plug

1. Is the ignition switch ON? (page 12).
2. Make sure the oil level is correct (page 35).
3. Remove the spark plug and clean, gap, or replace as necessary (page 38).
4. If the engine still will not start, take the pump to an authorized Honda servicing dealer.

PUMP WILL NOT PUMP

1. Is the strainer clogged? (page 21).
2. Is there a restriction or foreign material in the pump casing?
3. Are the suction hose clamps installed securely? (page 21).
4. Is suction hose connector sealing washer installed? (page 21).
5. Is the suction hose or suction hose nipple face damaged?
6. Is the suction head too high? (page 22).
7. Does the pump require priming? (page 22).
8. Is debris under clappet valves or are valves damaged? (page 45).
9. Is the diaphragm torn? (see page 47).
10. If the pump still does not pump, take the pump to an authorized Honda servicing dealer.

STORAGE

This chapter tells you how to protect your pump, and ensure that it will start easily when you want to use it again.

STORAGE PREPARATION	56
Cleaning.....	56
Engine	56
Pump	56
Fuel	57
Adding fuel stabilizer to extend fuel storage life.....	57
Draining the Fuel Tank and Carburetor	58
Engine Oil	58
Air Cleaner.....	59
Engine Cylinder	59
PLACING IN STORAGE	60
REMOVAL FROM STORAGE	60

STORAGE

STORAGE PREPARATION

The following steps will help to keep rust and corrosion from impairing your pump's function and appearance, and will make the engine easier to start when you use the pump again.

Cleaning

Engine

Wash the engine by hand, and be careful to prevent water from entering the air cleaner or muffler.

NOTICE

- Using a garden hose or pressure washing equipment can force water into the air cleaner. Water in the air cleaner will soak the filter and can enter the carburetor or engine, causing damage.
- Water contacting a hot engine can cause damage. If the engine has been running, allow it to cool for at least half an hour before washing.

Pump

1. Flush the pump chamber (see page 43).
2. Wash the pump with a garden hose or other low pressure equipment. Keep water away from controls, and all other places that are difficult to dry, as water may promote rust.
3. After washing: Remove as much standing water as possible with a dry cloth. Start the engine outdoors and let it run until it reaches normal operating temperature to evaporate any water remaining on the engine.
4. Stop the engine, and allow it to cool.
5. After the pump is clean and dry, touch up any damaged paint, and coat other areas that may rust with a light film of oil. Lubricate controls with a silicone spray lubricant.

Fuel

Gasoline will oxidize and deteriorate in storage. Old gasoline will cause hard starting, and it leaves gum deposits that clog the fuel system. If the gasoline in your pump's engine deteriorates during storage, you may need to have the carburetor and other fuel system components serviced or replaced.

The length of time that gasoline can be left in your fuel tank and carburetor without causing functional problems will vary with such factors as gasoline blend, your storage temperatures, and whether the fuel tank is partially or completely filled. The air in a partially filled fuel tank promotes fuel deterioration. Very warm storage temperatures accelerate fuel deterioration. Fuel deterioration problems may occur within a few months, or even less if the gasoline was not fresh when you filled the fuel tank.

The Distributor's Limited Warranty does not cover fuel system damage or engine performance problems resulting from neglected storage preparation.

You can extend fuel storage life by adding a fuel stabilizer that is formulated for that purpose, or you can avoid fuel deterioration problems by draining the fuel tank and carburetor.

Adding fuel stabilizer to extend fuel storage life

Fill the fuel tank with fresh gasoline. If only partially filled, air in the tank will promote fuel deterioration during storage. If you keep a container of gasoline for refueling, be sure that it contains only fresh gasoline.

1. Add fuel stabilizer following manufacturer instructions.
2. After adding a fuel stabilizer, run the engine outdoors for 10 minutes to be sure that treated gasoline has replaced the untreated gasoline in the carburetor.
3. Stop the engine, and turn the fuel valve to the OFF position. Drain the pump chamber.

STORAGE

Draining the Fuel Tank and Carburetor

1. Remove the carburetor drain screw with a 10 mm wrench or screwdriver, and drain the fuel system into an approved gasoline container.

⚠ WARNING

Gasoline is highly flammable and explosive.

You can be burned or seriously injured when handling fuel.

- Stop the engine and keep heat, sparks, and flame away.
- Handle fuel only outdoors.
- Wipe up spills immediately.

2. Turn the fuel valve to the ON position. This will allow fuel in the fuel tank to drain through the carburetor bowl.

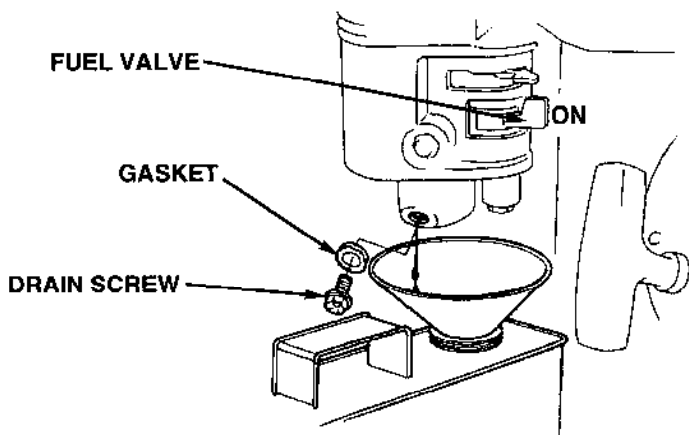

3. Reinstall the drain screw and gasket.

Engine Oil

Change the engine oil (see page 34).

Air Cleaner

Check the air filter and clean as necessary (see page 36).

Engine Cylinder

1. Remove the spark plug (see page 38). Pour a tablespoon (5 - 10 cc) of clean engine oil into the cylinder. Slowly pull the recoil starter rope a few times to distribute the oil in the cylinder. Reinstall the spark plug.
2. Pull the starter rope slowly until resistance is felt. Continue pulling slowly until the arrow notch on the starter pulley aligns with the hole on the recoil starter. Return the starter grip gently. This will close the valves so moisture can not enter the engine cylinder.

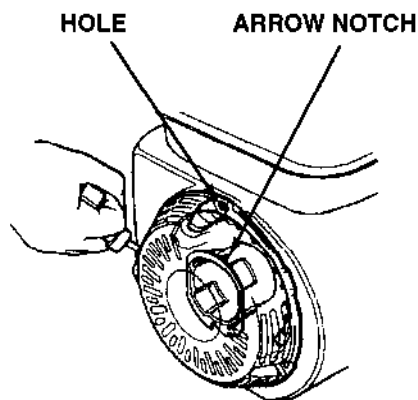

STORAGE

PLACING IN STORAGE

If your pump will be stored with gasoline in the fuel tank and carburetor, it is important to reduce the hazard of gasoline vapor ignition. Select a well ventilated storage area away from any appliance that operates with a flame, such as a furnace, water heater, or clothes dryer. Also avoid any area with a spark producing electric motor, or where power tools are operated.

If possible, avoid storage areas with high humidity, because that promotes rust and corrosion.

Unless all fuel has been drained from the fuel tank, leave the fuel valve in the OFF position to reduce the possibility of fuel leakage.

Place the pump on a level surface. Tilting can cause fuel or oil leakage.

With the engine and exhaust system cool, cover the pump to keep out dust. A hot engine and exhaust system can ignite or melt some materials.

Do not use sheet plastic as a dust cover. A nonporous cover will trap moisture around the pump, promoting rust and corrosion.

REMOVAL FROM STORAGE

Check your pump as described in the BEFORE OPERATION chapter of this manual.

If the fuel was drained during storage preparation, fill the tank with fresh gasoline. If you keep a container of gasoline for refueling, be sure that it contains only fresh gasoline. Gasoline oxidizes and deteriorates over time, causing hard starting.

If the cylinder was coated with oil during storage preparation, the engine may smoke briefly at startup. This is normal.

SPECIFICATIONS

This chapter gives you dimensions, capacities, and other technical information.

DIMENSIONS AND WEIGHT	62
ENGINE DESIGN AND PERFORMANCE	62
PUMP	62
GEAR BOX	62
MAINTENANCE	63
TUNEUP	63
PUMP PERFORMANCE CURVE	64
WIRING DIAGRAM	64

SPECIFICATIONS

DIMENSIONS AND WEIGHT

Model	WDP20X	WDP30X
Description code	WZBZ	WZCA
Length x Width x Height	32.5 x 23.4 x 25.0 in (826 x 594 x 635 mm)	
Dry Weight	120 lbs (54.4 kg)	

ENGINE DESIGN AND PERFORMANCE

Model	GX120K1QX2
Engine type	4-stroke, overhead-valve, single cylinder
Displacement [bore x stroke]	7.2 cu in (119 cc) [2.4 x 1.7 in (60 x 42 mm)]
Maximum output	4.0 hp (2.9 kw) at 3,600 rpm
Cooling system	Forced air
Ignition system	Transistorized magneto
PTO shaft direction	Counterclockwise

PUMP

Pump type	Diaphragm with spring-type connecting rod	
Suction port diameter/thread type	2 in (50.8 mm) NPT	3 in (76.2 mm) NPT
Discharge port diameter/thread type		
Maximum total head	50 ft (15 m)	
Maximum suction head (dry)	14 ft (4.3 m)	16 ft (4.9 m)
Maximum suction head (after priming pump housing)	21 ft (6.4 m)	24 ft (7.3 m)
Maximum discharge capacity	60 gpm (227 l/min)	80 gpm (303 l/min)
Self-priming time	20 sec. at 20 ft (6.1 m)	
Maximum solid size	1.8 in (46 mm)	2.4 in (60 mm)
Diaphragm	Neoprene with nylon cloth	
Valves	Neoprene with cast iron inserts	

GEAR BOX

Pump operating frequency	73 strokes/min.	
Gear reduction	43:1	
Pump stroke	2.56 in (65.0 mm)	2.77 in (70.4 mm)
Gear box oil capacity	0.8 qt (0.8 l)	
Gear box oil type	80W/90 GL5 gear oil	

MAINTENANCE

Fuel	Unleaded gasoline with a pump octane rating of 86 or higher	See page 41
Engine oil	SAE 10W-30, API SH or SJ	See page 35
Gear box oil	SAE 80W/90 GL5 gear oil	See page 44
Spark plug type	NGK – BPR6ES DENSO – W20EPR-U	See page 38
Maximum governed speed	3,000 ~ 3,150 rpm	See shop manual.

TUNEUP

Spark Plug Gap	0.028 - 0.031 in (0.70 - 0.80 mm)	See page 38.
Carburetor Idle Speed	1,400 ⁺²⁰⁰ -150 rpm	See page 40.
Valve Clearance (cold)	Intake: 0.15 ± 0.02 mm Exhaust: 0.20 ± 0.02 mm	See shop manual.
Other Specifications	No other adjustments needed.	

SPECIFICATIONS

PUMP PERFORMANCE CURVE *

This graph shows the relationship between the pump discharge capacity and the total dynamic head. As you increase the total head, the discharge capacity will decrease.

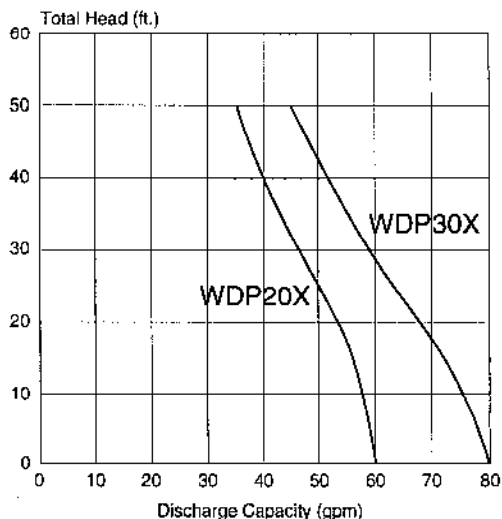

* Based on clear water at sea level.

WIRING DIAGRAM

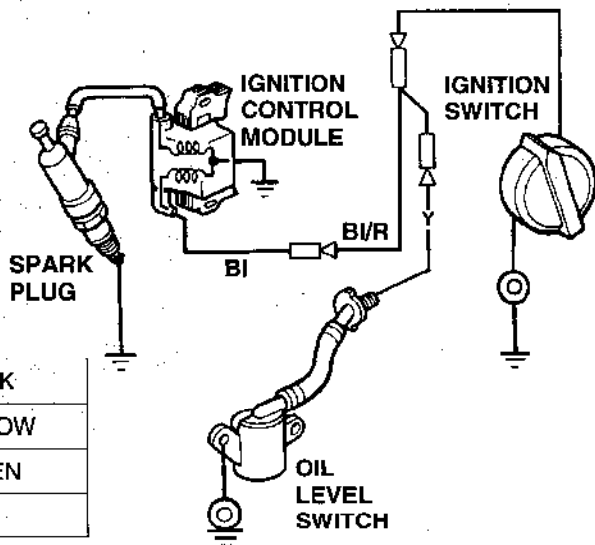

BI	BLACK
Y	YELLOW
G	GREEN
R	RED

ADDITIONAL INFORMATION

This chapter contains additional information, Honda publications available to you, and tells you how to contact us if you have a question or a warranty repair problem.

HONDA PUBLICATIONS	66
Shop Manual	66
Parts Catalog	66
WARRANTY SERVICE INFORMATION	66
OXYGENATED FUELS	67
EMISSION CONTROL SYSTEM INFORMATION	68
Source of Emissions	68
The U.S. and California Clean Air Acts	68
Tampering and Altering	68
Problems that May Affect Emissions	68
Replacement Parts	69
Maintenance	69
SPARK ARRESTER SERVICE (optional equipment) ...	70

ADDITIONAL INFORMATION

HONDA PUBLICATIONS

These publications will give you additional information about maintaining your pump. You may order them from your Honda water pump dealer.

Shop Manual

This manual covers complete maintenance and overhaul procedures. It is intended to be used by a skilled technician.

Parts Catalog

This provides a complete pictorial parts listing.

WARRANTY SERVICE INFORMATION

Honda power equipment dealership personnel are trained professionals. They should be able to answer any question you may have. If you encounter a problem that your dealer does not solve to your satisfaction, please discuss it with the dealership's management. The Service Manager or General Manager can help. Almost all problems are solved in this way.

If you are dissatisfied with the decision made by the dealership's management, contact the Honda Power Equipment Customer Relations Office. You can write to:

American Honda Motor Co., Inc.
Power Equipment Division
Customer Relations Office
4475 River Green Parkway
Duluth, Georgia 30096-2565

Or telephone: (770) 497-6400

When you write or call, please give us this information:

- Model and serial number (see page 10)
- Name of dealer who sold the pump to you
- Name and address of dealer who services your pump
- Date of purchase
- Your name, address, and telephone number
- A detailed description of the pump application and problem

Current customer service contact information:

United States, Puerto Rico, and U.S. Virgin Islands:

Honda Power Equipment dealership personnel are trained professionals. They should be able to answer any question you may have. If you encounter a problem that your dealer does not solve to your satisfaction, please discuss it with the dealership's management. The Service Manager or General Manager can help. Almost all problems are solved in this way.

If you are dissatisfied with the decision made by the dealership's management, contact the Honda Power Equipment Customer Relations Office. You can write:

American Honda Motor Co., Inc.
Power Equipment Division
Customer Relations Office
4900 Marconi Drive
Alpharetta, GA 30005-8847

Or telephone: (770) 497-6400 M-F, 8:30 am - 7:00 pm EST

When you write or call, please provide the following information:

- Model and serial numbers
- Name of the dealer who sold the Honda power equipment to you
- Name and address of the dealer who services your equipment
- Date of purchase
- Your name, address, and telephone number
- A detailed description of the problem

OXYGENATED FUELS

Some conventional gasolines are being blended with alcohol or an ether compound. These gasolines are collectively referred to as oxygenated fuels. To meet clean air standards, some areas of the United States and Canada use oxygenated fuels to help reduce emissions.

If you use an oxygenated fuel, be sure it is unleaded and meets the minimum octane rating requirements.

Before using an oxygenated fuel, try to confirm the fuel's contents. Some states/provinces require this information to be posted on the pump.

The following are the EPA approved percentages of oxygenates:

ETHANOL — (ethyl or grain alcohol) 10% by volume
You may use gasoline containing up to 10% ethanol by volume. Gasoline containing ethanol may be marketed under the name "Gasohol".

MTBE — (methyl tertiary butyl ether) 15% by volume
You may use gasoline containing up to 15% MTBE by volume.

METHANOL — (methyl or wood alcohol) 5% by volume
You may use gasoline containing up to 5% methanol by volume as long as it also contains cosolvents and corrosion inhibitors to protect the fuel system. Gasoline containing more than 5% methanol by volume may cause starting and/or performance problems. It may also damage metal, rubber, and plastic parts of your fuel system.

If you notice any undesirable operating symptoms, try another service station or switch to another brand of gasoline.

Fuel system damage or performance problems resulting from the use of an oxygenated fuel containing more than the percentages of oxygenates mentioned above are not covered under warranty.

ADDITIONAL INFORMATION

EMISSION CONTROL SYSTEM INFORMATION

Source of Emissions

The combustion process produces carbon monoxide, oxides of nitrogen, and hydrocarbons. Control of hydrocarbons and oxides of nitrogen is very important because, under certain conditions, they react to form photochemical smog when subjected to sunlight. Carbon monoxide does not react in the same way, but it is toxic.

Honda utilizes lean carburetor settings and other systems to reduce the emissions of carbon monoxide, oxides of nitrogen, and hydrocarbons.

The U.S. and California Clean Air Acts

EPA and California regulations require all manufacturers to furnish written instructions describing the operation and maintenance of emission control systems.

The following instructions and procedures must be followed in order to keep the emissions from your Honda engine within the emission standards.

Tampering and Altering

Tampering with or altering the emission control system may increase emissions beyond the legal limit. Among those acts that constitute tampering are:

- Removal or alteration of any part of the intake, fuel or exhaust systems.
- Altering or defeating the governor linkage or speed adjusting mechanism to cause the engine to operate outside its design parameters.

Problems that may Affect Emissions

If you are aware of any of the following symptoms, have your engine inspected and repaired by your servicing dealer.

- Hard starting or stalling after starting.
- Rough idle.
- Misfiring or backfiring under load.
- Afterburning (backfiring).
- Black exhaust smoke or high fuel consumption.

Replacement Parts

The emission control systems on your new Honda engine were designed, built, and certified to conform with EPA and California emission regulations. We recommend the use of genuine Honda parts whenever you have maintenance done. These original-design replacement parts are manufactured to the same standards as the original parts, so you can be confident of their performance. The use of replacement parts that are not of the original design and quality may impair the effectiveness of your emission control system.

A manufacturer of an aftermarket part assumes the responsibility that the part will not adversely affect emission performance. The manufacturer or rebuilder of the part must certify that use of the part will not result in a failure of the engine to comply with emission regulations.

Maintenance

Follow the maintenance schedule on page 32. Remember that this schedule is based on the assumption that your machine will be used for its designed purpose. Sustained high-load or high-temperature operation, or use in unusually wet or dusty conditions, will require more frequent service.

ADDITIONAL INFORMATION

SPARK ARRESTER SERVICE (optional equipment)

The spark arrester must be serviced every 100 hours to keep it functioning as designed.

1. Allow the engine to cool, then remove the two 8 mm nuts and remove the muffler from the cylinder head.
2. Remove the four 5 mm screws from the muffler protector and remove the muffler protector.
3. Remove the 4 mm screw from the spark arrester and remove the spark arrester from the muffler.

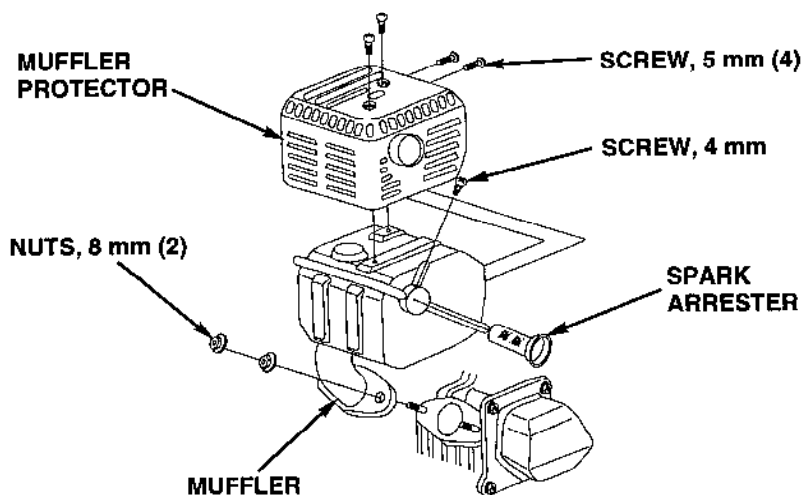

4. Use a soft brush to remove carbon deposits from the spark arrester screen. Be careful not to damage the spark arrester screen.
5. Inspect the spark arrester for breaks and holes. Replace it if necessary.
6. Install the spark arrester and the muffler in the reverse order of disassembly.

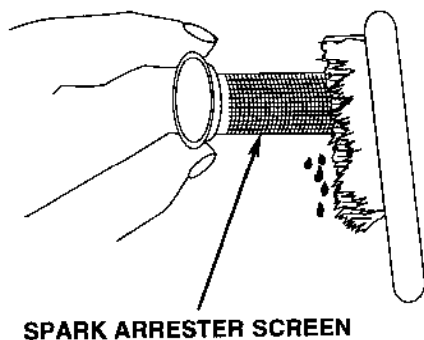

INDEX

A

- Air Cleaner:
 - Clean37
 - Inspect36

C

- Carburetor:
 - Idle Speed Adjustment.....40
 - High Altitude Operation.....40
- Choke Lever11
- Component Identification.....10

D

- Description of Controls11
- Discharge Hose Connection..22

E

- Emission Control System
 - Information68
- Engine:
 - Oil Change.....34
 - Oil Level Check.....35
 - Specifications.....62
 - Starting23
 - Stopping25
 - Troubleshooting.....54

F

- Fuel:
 - Filter/Fuel Line42
 - Oxygenated67
 - Recommendations.....41
 - Refueling33
 - Sediment Cup Cleaning.....41
 - Valve Lever.....11

H

- Head:
 - Suction, Discharge, Total ..62

I

- Ignition Switch12

L

- Liquid Pumping
 - Recommendations.....6

M

- Maintenance Safety.....31
- Maintenance Schedule.....32

O

- Oil Alert System.....12
- Oil, Engine:
 - Change34
 - Level Check.....35
 - Recommendations35

P

- Pre-Operation Checks.....13
- Publications68
- Pump:
 - Clappets45
 - Diaphragm.....47
 - Gear Box44
 - Performance.....64
 - Performance Curve64
 - Priming22
 - Specifications62
 - Troubleshooting.....54

R

- Recoil Starter.....12

INDEX

S

Safety:

Important Safety Information	6
Maintenance	31
Safety Label Locations.....	8
Safety Message Definitions	2
Serial Numbers	10
Spark Arrester Service.....	70
Spark Plug Service	38
Specifications.....	61
Starting the Engine	23
Stopping the Engine	25
Emergency.....	25
Normal	25
Storage Preparation.....	56
Suction Hose Connection	21

T

Throttle Lever.....	11
Transporting Your Pump.....	27
Troubleshooting:	
Engine Will Not Start.....	54
Pump Will Not Pump.....	54

W

Warranty Service Information	66
Wiring Diagram	64

QUICK REFERENCE INFORMATION

Fuel	Type	Unleaded gasoline with pump octane rating of 86 or higher (page 41).
	Capacity	0.66 US gallons (2.5 ℓ)
Engine Oil	Type	SAE 10W-30, API SH or SJ (page 35)
	Capacity	0.6 US quarts (0.6 ℓ)
Spark Plug	Type	Resistor: NGK – BPR6ES DENSO – W20EPR-U
	Gap	0.028 - 0.031 in (0.70 ~ 0.80 mm) (page 38)
Carburetor	Idle speed	1,400 ⁺²⁰⁰ ₋₁₅₀ rpm (page 40)
Maintenance	Before each use	Check fuel level (page 33). Check engine oil level (page 35). Check air cleaner (page 36). Check pump hoses and strainer (page 43).
	First 20 hours	Change engine oil (page 34). Grease pump connecting rod bearing (page 44).
	Subsequent	Refer to maintenance schedule on page 32.
	After each use	Flush pump chamber (page 43).

HONDA

31TDP600
00X31-TDP-6000



Printed on
Recycled Paper



ECP

6009804

PRINTED IN U.S.A.