

**HONDA**

**Power**

**Equipment**

# OWNER'S MANUAL

## Mini-Tiller FG100



**HONDA**

***Harmony***

*¿Necesita un manual en Español? Vea a la página 44.*

*See page 28 for instructions on assembling your FG100 Mini-Tiller.*

 **WARNING:** 

The engine exhaust from this product contains chemicals known to the State of California to cause cancer, birth defects, or other reproductive harm.

Keep this owner's manual handy so you can refer to it at any time. This should remain with the tiller if resold.

The information and specifications included in this publication were in effect at the time of approval for printing. American Honda Motor Co., Inc. reserves the right, however, to discontinue or change specifications or design at any time without notice and without incurring any obligation whatever. No part of this publication may be reproduced without written permission.

## INTRODUCTION

Congratulations on your selection of a Honda Harmony FG100 Tiller. We are certain you will be pleased with your purchase of one of the finest tillers on the market.

We want to help you get the best results from your new tiller and to operate it safely. This manual contains the information on how to do that; please it carefully.

As you read this manual, you will find information preceded by a NOTICE symbol. That information is intended to help you avoid damage to your tiller, other property, or environment.

We suggest you read the warranty policy to fully understand its coverage and your responsibilities of ownership.

When your tiller needs scheduled maintenance, keep in mind that your Honda servicing dealer is specially trained in servicing Honda tillers. Your Honda servicing dealer is dedicated to your satisfaction and will be pleased to answer your questions and concerns.

Left and right sides of this unit are determined from the operator's position, standing behind the tiller handlebars, facing the direction of forward travel.

Best Wishes,

Power Equipment Division  
American Honda Motor Co., Inc.

## A FEW WORDS ABOUT SAFETY

Your safety and the safety of others are very important. And using this tiller is an important responsibility.

To help you make informed decisions about safety, we have provided operating procedures and other information on labels in this manual. This information alerts you to potential hazards that could hurt you or others.

Of course, it is not practical or possible to warn you about all the hazards associated with operating or maintaining a tiller. You must use your own good judgment.

You will find important safety information in a variety of forms, including:

- Safety Labels - on the tiller
- Safety Messages - preceded by a safety alert symbol  and of the following three words; DANGER, WARNING, or CAUTION.

These signal words mean:

 **DANGER**

You **WILL** be Killed or **SERIOUSLY HURT** if you don't follow instructions.

 **WARNING**

You **CAN** be **KILLED** or **SERIOUSLY HURT** if you don't follow instructions.

 **CAUTION**

You **CAN BE HURT** if you don't follow instructions.

- Safety Headings - such as IMPORTANT SAFETY INFORMATION.
- Safety Section - such as TILLER SAFETY.
- Instructions - how to use this tiller correctly and safely.

This entire book is filled with important safety information - please read it carefully.

**CONTENTS**

SAFETY .....	4	ASSEMBLY .....	28
IMPORTANT SAFETY INFORMATION.....	4	THE IMPORTANCE OF ASSEMBLY .....	28
ATTACHMENTS AND MODIFICATIONS .....	5	UNPACKING .....	29
IMPORTANT MESSAGE TO EMPLOYERS .....	5	LOOSE PARTS .....	29
IMPORTANT MESSAGE TO PARENTS .....	5	TILLER ASSEMBLY .....	30
SAFETY LABEL LOCATIONS .....	6	TRANSPORTING/STORAGE.....	34
CONTROLS .....	7	TRANSPORTING .....	34
COMPONENT IDENTIFICATION .....	7	STORAGE .....	34
DESCRIPTION OF CONTROLS.....	8	TAKING CARE OF UNEXPECTED	
Throttle Lever . . . . .	8	PROBLEMS.....	37
Engine Switch . . . . .	8	STARTING PROBLEMS.....	37
Handle Bar Adjustment . . . . .	8	ENGINE OPERATING PROBLEMS .....	37
Choke Lever . . . . .	8	SPECIFICATIONS.....	38
Priming Bulb . . . . .	8	TECHNICAL & CONSUMER	
Transport Wheels . . . . .	9	INFORMATION.....	39
Carrying Handle . . . . .	9	SERIAL NUMBER LOCATIONS.....	39
Recoil Starter Grip . . . . .	9	HONDA PUBLICATIONS .....	39
Drag Bar . . . . .	9	OPTIONS.....	39
BEFORE OPERATION .....	10	WARRANTY .....	40
GENERAL.....	10	EMISSION CONTROL	
CHECK TILLING AREA .....	11	SYSTEM WARRANTY .....	42
CHECK TILLER .....	11	WARRANTY SERVICE INFORMATION .....	44
OPERATION.....	12	OXYGENATED FUELS .....	45
SAFETY PRECAUTIONS .....	12	HIGH ALTITUDE OPERATION .....	45
MOVING THE TILLER.....	12	EMISSION CONTROL	
HANDLEBAR ADJUSTMENT .....	12	SYSTEM INFORMATION.....	46
STARTING/STOPPING THE ENGINE .....	13	QUICK REFERENCE.....	Back Cover
TILLER OPERATION.....	14	Maintenance.....	Back Cover
MAINTENANCE & ADJUSTMENTS .....	17	Tuneup.....	Back Cover
THE IMPORTANCE OF MAINTENANCE.....	17		
MAINTENANCE SAFETY .....	17		
MAINTENANCE SCHEDULE .....	18		
Engine Oil . . . . .	19		
Air Filter . . . . .	20		
Spark Plug . . . . .	22		
Spark Arrester . . . . .	23		
Cooling Fins . . . . .	24		
Throttle Cable . . . . .	24		
Idle Speed . . . . .	24		
Fuel System . . . . .	25		
Transmission . . . . .	27		

# SAFETY

---

## IMPORTANT SAFETY INFORMATION

Most accidents with this product can be prevented if you follow all instructions in this manual and on the product. The most common hazards, according to accident statistics, are discussed below, along with the best way to protect yourself and others.

### **Honda Tiller Usage**

Honda tillers are designed to give safe and dependable service if operated according to instructions and intended use.

Honda tillers are intended to be used by an experienced, trained, operator who is familiar with the use of power equipment. Do not allow a child or an inexperienced, untrained operator to use this tiller. Operating this equipment requires special effort on your part to ensure your safety and the safety of others. Read and understand this owner's manual.

### **Avoid Rotating Tines**

The rotating tines can cause injury. Keep away from the tine shield whenever the engine is running. If you need to adjust the tines, or work around the tines for any reason, always stop the engine. Disconnect the spark plug cap if you need to clean or handle the tines.

### **Clear Tilling Area**

The tiller tines can throw rocks and other objects with enough force to cause injury. Before tilling, carefully inspect the area and remove all large debris.

### **Keep Shields in Place**

Guards and shields are designed to protect you from being hit by thrown objects and from hot engine parts and moving components. For your safety and the safety of others, keep all shields in place when operating the tiller.

### **Refuel with Care**

Gasoline is extremely flammable and gasoline vapor can explode. Refuel only outdoors, in a well-ventilated area, with the engine off. Never smoke near gasoline, and keep other flames and sparks away. Always store gasoline in an approved container.

### **Wear Protective Clothing**

Wearing protective clothing will reduce your risk of injury. Long pants and eye protection reduce the risk of injuries from thrown objects. Sturdy shoes with aggressive soles will help protect your feet and give you better traction on slopes or uneven ground. Clothing worn by the operator should be fairly tight and belted. Loose clothing should not be permitted because of the danger of getting into moving parts. Tie up or restrain long hair.

### **Turn Engine Off When Not Tilling**

If you need to leave the tiller for any reason, even just to inspect the area ahead, always stop the engine .

---

## ATTACHMENTS AND MODIFICATIONS

Do not make any modifications to your tiller. Modifying your tiller, or installing non-Honda attachments, can make your tiller unsafe.

If you need attachments for your tiller, use only genuine Honda attachments. These products have been designed for your tiller and are covered by warranty.

Non-Honda attachments are usually designed for universal applications. Although aftermarket attachments may fit on your tiller, they may not meet factory specifications and could make your tiller unsafe.

## IMPORTANT MESSAGE TO EMPLOYERS

As an employer, you have special responsibilities to the people who work for you.

Before you ask anyone to operate this tiller, you need to determine whether the person is old enough, large enough, and strong enough to safely handle and control the tiller.

If you decide they are, make sure the employee reads and understands all instructions and warnings in this manual, and on the labels before operating the tiller.

Allow adequate time for hands-on training by a qualified instructor, and personally supervise practice sessions until you feel sure the employee is ready to operate the tiller.

Also be sure employees wear proper clothing and have eye protection and any other gear that may be required by local ordinances or your insurance company.

Remember, too, that you are responsible for keeping the tiller properly maintained and in safe operating condition.

Your commitment to safety on the job can help prevent accidents and result in longer and more productive years of service.

## IMPORTANT MESSAGE TO PARENTS

Your child's safety is very important to Honda. Read this message if you decide to permit your youngster to operate this tiller. Tillers are tools, not toys. As with any equipment, bad judgments can result in serious injuries. You can prevent accidents by making good decisions about if, when, and how your youngster operates this equipment.

The first question you'll need to ask is whether your youngster is capable of operating this tiller safely. Remember, young people vary widely, and **AGE IS NOT THE ONLY FACTOR**. Physically, a youngster must be **LARGE ENOUGH AND STRONG ENOUGH** to easily start the tiller and control its direction. The youngster also needs enough size, strength, and coordination to comfortably reach and operate the controls.

Another, tougher question you need to ask is if your youngster has enough **MATURITY AND RESPONSIBILITY** to safely operate this tiller. Does the young person think through problems and come to logical solutions? Be honest! Anyone who takes unnecessary risks and doesn't obey rules should not operate this tiller.

If you decide that your son or daughter can handle the tiller safely, carefully read the owner's manual with your youngster. Make sure you both understand all instructions and safety information. Also, be sure your youngster wears sturdy shoes and other protective clothing when operating or handling the tiller.

**SUPERVISION** is important. Walk behind your youngster during the first few minutes of tilling. Even after the youngster is confident, do not let them use the tiller without supervision. An adult should also be present during refueling and maintenance. Be sure the tiller is properly maintained and kept in safe operating condition.

By always placing safety first, your youngster will acquire useful skills and a sense of accomplishment, and you'll both get the best results from your tiller.

# SAFETY

## SAFETY LABEL LOCATIONS

The labels shown here contain important safety information. Please read them carefully. These labels are considered permanent parts of your Honda tiller. If a label comes off or becomes hard to read, immediately contact a Honda tiller servicing dealer for a replacement label.

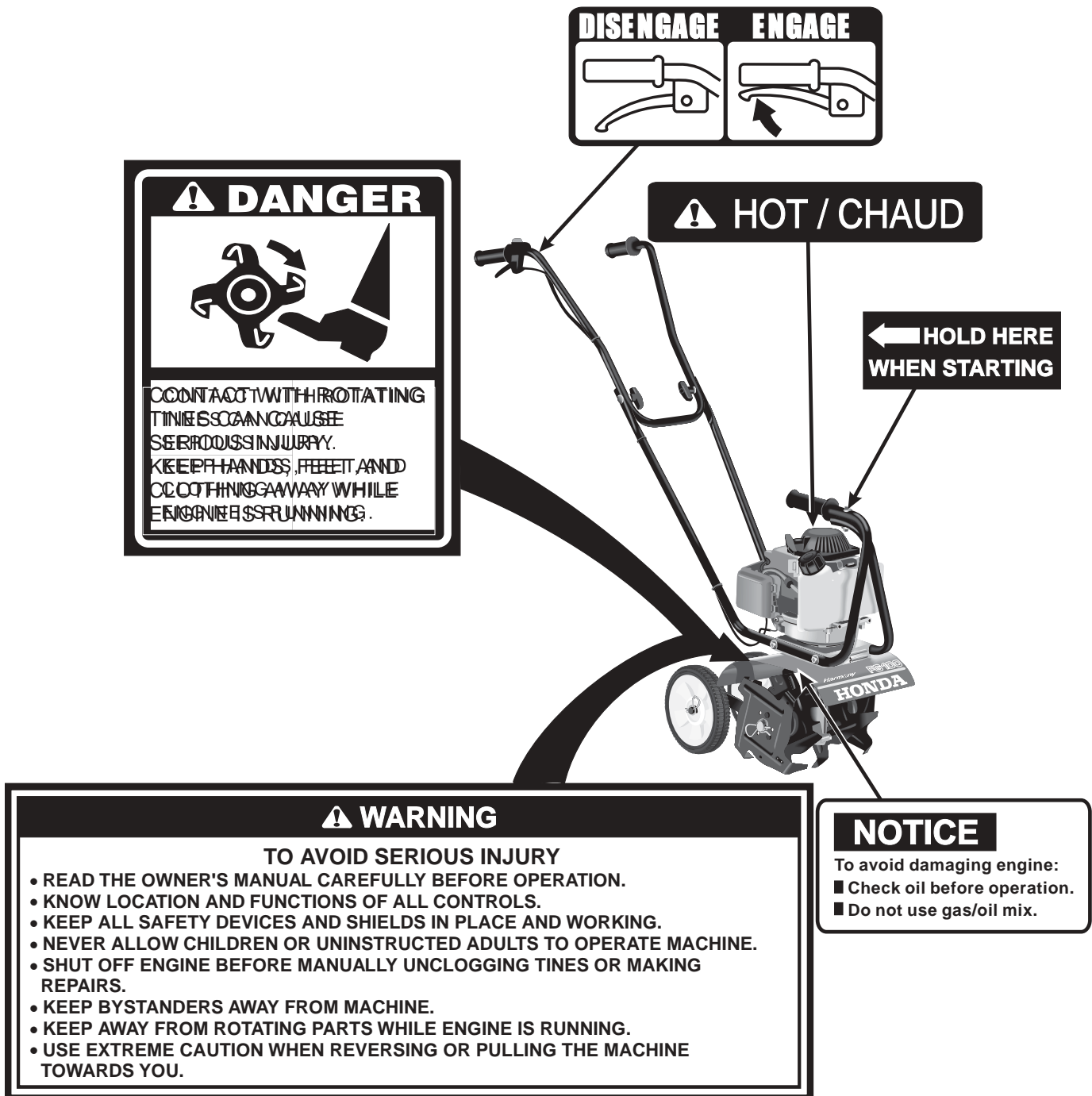



COMPONENT IDENTIFICATION

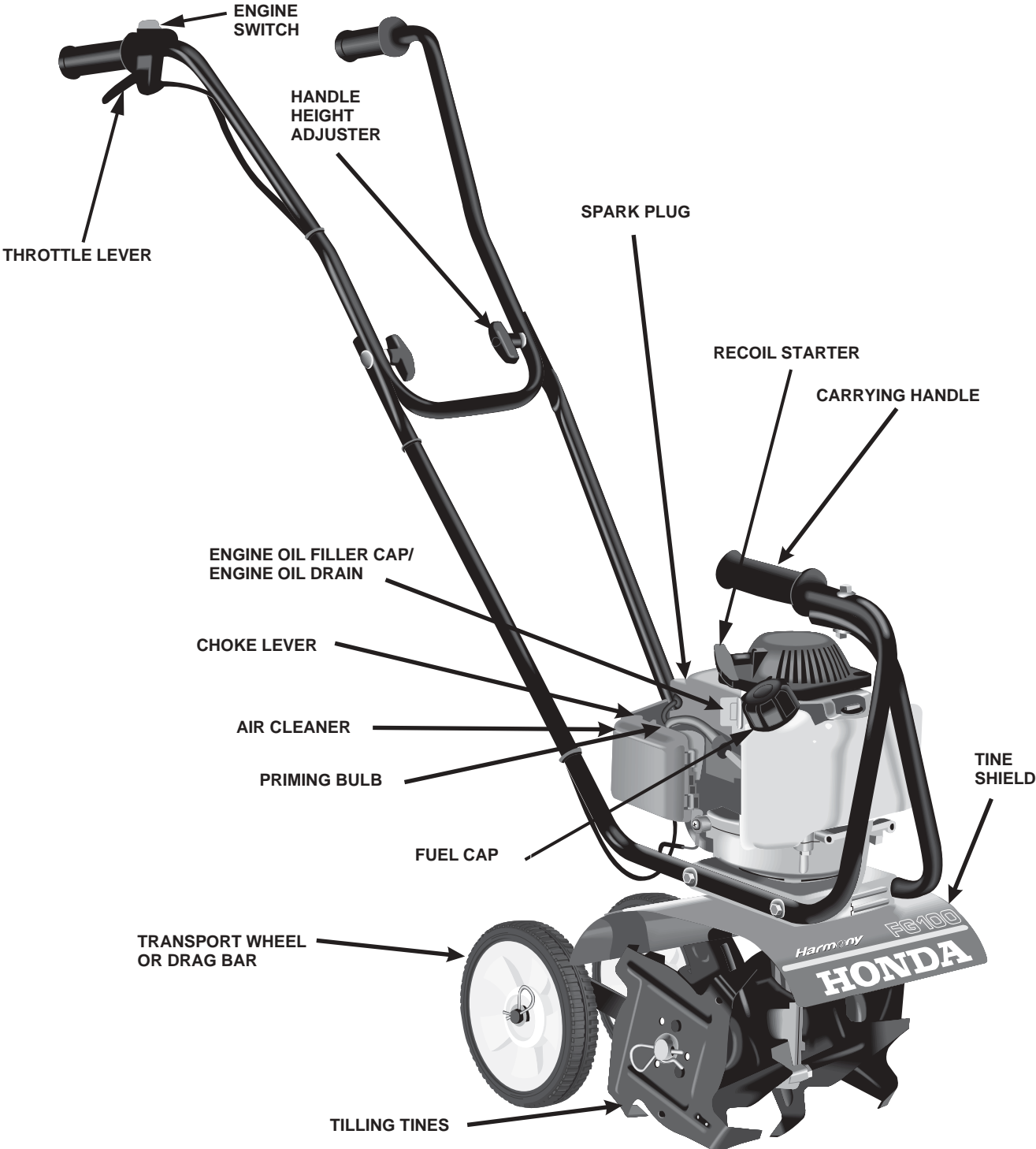

# CONTROLS

## DESCRIPTION OF CONTROLS

### Throttle Lever

The throttle lever controls engine speed and tiller tine rotation.

Pulling the throttle lever towards the grip increases the engine speed which causes the tines to turn. Releasing the throttle lever reduces engine speed and stops the tiller tines from turning.

The tiller will have the greatest tilling force at maximum engine speed. At idle, the tilling tines should stop rotating.

### Engine Switch

The engine switch controls the ignition system.

The engine switch must be in the ON position for the engine to start and run. Moving the engine switch to the OFF position stops the engine.

### Handle Bar Adjustment

There are two positions that the handlebars can be adjusted to best suit the height of the operator.

### Choke Lever

The choke lever opens and closes the choke valve in the carburetor.

The CLOSED position enriches the fuel mixture for starting a cold engine. The OPEN position provides the correct fuel mixture for operation after starting, and for restarting a warm engine.

### Priming Bulb

Pressing the priming bulb pumps fuel from the fuel tank to the carburetor. This procedure is necessary for starting a cold engine and after refueling an engine that has run out of fuel.

To ensure that fuel has reached the carburetor, press the priming bulb repeatedly until fuel can be seen in the clear-plastic fuel-return tube.

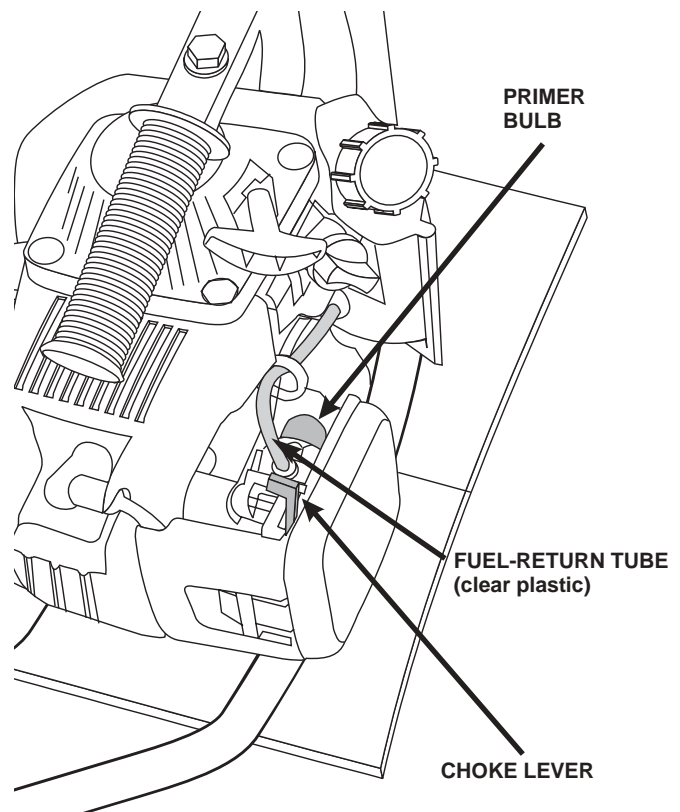
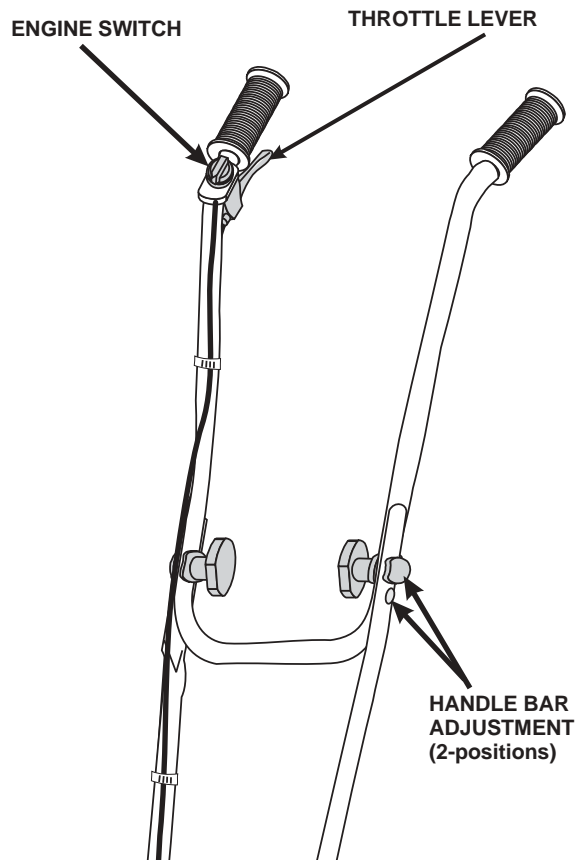

### Transport Wheels

The transport wheels are used to move the tiller around. Before tilling, the transport wheels must be removed and the drag bar installed in their place.

### Carrying Handle

The carrying handle rubber grip is used to hold the tiller when starting the engine.

The carrying handle can be used to load/unload the tiller, and to assist in certain engine maintenance procedures.

### Recoil Starter Grip

Pulling the starter grip operates the recoil starter to crank the engine for starting.

### Drag Bar

The drag bar is used to control the forward action of the turning tiller tines. The drag bar can be adjusted to control the tilling depth of the tines.

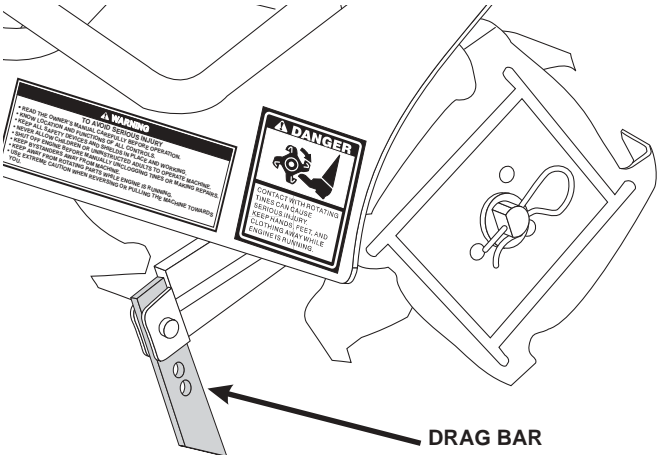
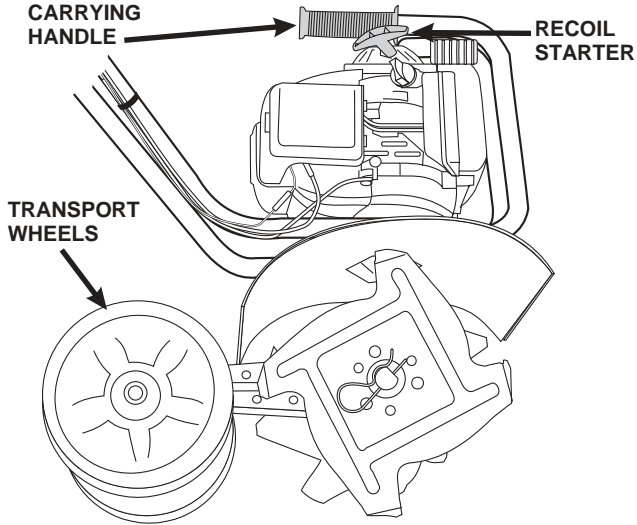

## BEFORE OPERATION

---

### ARE YOU READY TO OPERATE THE TILLER?

Your safety is your responsibility. A little time spent in preparation will significantly reduce your risk of injury.

#### Knowledge

Read and understand this manual. Know what the controls do and how to operate them.

Familiarize yourself with the tiller and its operation before you begin to use it. Know what to do in case of emergencies.

#### Physical and Mental Readiness

You must be alert and in good physical condition to operate the tiller. Do not operate the tiller if you are tired, ill, or under the influence of alcohol, medication, or any substance that might impair your vision, dexterity, or judgment.

If you have any physical problem that may be aggravated by strenuous work, consult your physician before operating the tiller.

#### Protective Clothing

Wearing protective clothing will reduce your risk of injury. Do not wear loose clothing, jewelry, short pants, sandals, or go barefoot. Secure hair so it is above shoulder level.

##### Eye, Face, and Head Protection

Always wear safety glasses or goggles that comply with ANSI standard Z87.1 to protect your eyes from thrown objects. Prescription glasses may be worn under the safety glasses or goggles.

Wearing a dust mask will help to reduce the amount of pollens and dust inhaled.

##### Hearing Protection

Hearing protectors will help to protect your ears from noise. Earmuff-style hearing protectors can also protect your ears from thrown objects.

##### Hand and Body Protection

Wear gloves, a long-sleeved shirt, and long pants made of heavy material. Clothing should fit closely but allow freedom of movement, and should have no strings, straps, etc. that could catch on brush or the tiller. Keep clothing fastened.

##### Foot Protection

Wear sturdy work boots with good toe protection and nonslip soles.

### IS YOUR WORKING AREA READY?

Objects thrown by the tiller can cause serious injury. Be especially careful when crossing gravel drives, walks or roads. Before operating the tiller, carefully inspect the area, and remove all objects that could be thrown by, or entangled in, the tilling attachment, such as rocks, broken glass, nails, wire, or string.

Never operate the tiller without good visibility or light.

Clear the area of children, bystanders, and pets. Keep all children, bystanders, and pets at least 50 feet (15 meters) away from where the tiller is being operated.

If anyone approaches you while you are operating the tiller, release the throttle lever and stop the engine.

### IS YOUR TILLER READY TO GO?

For your safety, and to maximize the service life of your equipment, it is very important to take a few moments before you operate the tiller to check its condition. Be sure to take care of any problem you find, or have your servicing dealer correct it, before you operate the tiller.

#### **WARNING**

Improperly maintaining this tiller, or failing to correct a problem before operation, could cause a malfunction in which you could be seriously injured. Always perform a pre-operation inspection before each operation, and correct any problem.

### Safety Inspection

- Look around the engine for signs of oil or gasoline leaks. Wipe up any spills before starting the engine.
- Replace any damaged parts.
- Check that all fasteners are in place and secure. Tighten as necessary.

### Tiller Tine Inspection

- Look for signs of damage to the tilling tines (or any accessory installed). Replace any tiller tines and parts that are worn out, bent, cracked, chipped, or damaged in any way.
- Make sure the tiller accessory is properly installed and securely fastened (see accessory operators manual).
- Check that the debris shield is securely installed and in good condition.

### Maintenance Inspection

**Check the oil level** (see page 19). Running the engine with a low oil level can cause engine damage.

**Check the air filter** (see page 20). A dirty air filter will restrict air flow to the carburetor, reducing engine and tiller performance.

**Check throttle operation** (see page 24). The throttle must operate smoothly for good throttle control.

**Check the fuel level** (see page 25). Starting with a full tank will help to eliminate or reduce operating interruptions for refueling.

# OPERATION

## SAFETY PRECAUTIONS

Before operating the tiller for the first time, please review the IMPORTANT SAFETY INFORMATION (see page 4) and the chapter titled BEFORE OPERATION (see page 10).

Even if you have operated other tillers, take time to become familiar with the operation of this tiller's controls and handling.

For your safety, avoid starting or operating the engine in an enclosed area, such as a garage. Your engine's exhaust contains poisonous carbon monoxide gas which can collect rapidly in an enclosed area and cause illness or death.

If the tiller starts to shake or vibrate, stop the engine immediately. After the tiller tines have completely stopped, inspect them to determine the cause of the vibration. Sudden vibration is a sign of a hazardous problem, such as loose or damaged tilling tines (or tiller accessory), hidden objects in the soil, or the ground that is too hard to till. Do not operate the tiller until the problem is corrected.

### Moving The Tiller

The tiller has transport wheels to allow easy maneuvering to and from the work area. There are four holes that the transport wheels can be set at. Select the hole that sets the handlebars at a height that provides comfortable tiller maneuvering.

Do not move the tiller with the engine running.

Before tilling, remove the transport wheels and install the drag bar.

### Drag Bar Installation

1. Make sure the engine is OFF before installing the drag bar.
2. Remove the lock pin and the 5/16 x 7/8 inch clevis pin. Remove the wheel assembly.
3. Install the drag bar with the pointed edge of the drag bar towards the tiller tines using the 5/16 x 7/8 inch clevis pin and lock pin.
4. When your tilling job is completed, reinstall the transport wheels in the reverse order of removal.

### Handlebar Adjustment

To adjust the handlebar height, remove the two handlebar knobs, 5/16-18 x 1 1/2 inch handlebar bolts, and curved washers. Move the upper handlebar hole to align with either the upper or lower holes in the lower handlebar assembly.

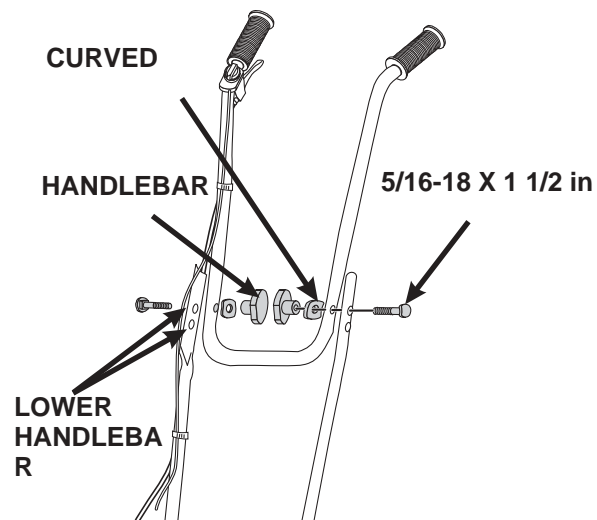
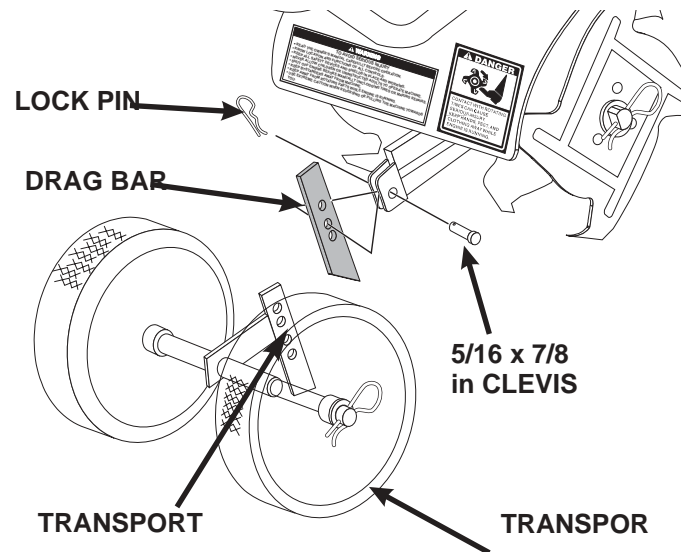

### Starting The Engine

1. Move the engine switch to the ON position.

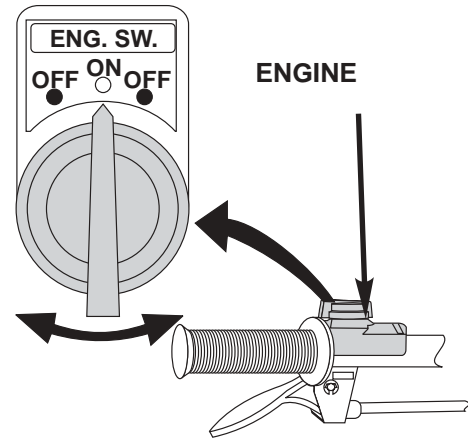

2. To start a cold engine, move the choke lever to the CLOSED (🔒) position.

To restart a warm engine, leave the choke lever in the OPEN position.

3. To start a cold engine, or after refueling an engine that has run out of fuel, press the priming bulb repeatedly until fuel can be seen in the clear plastic fuel-return tube.

To restart a warm engine, it is not necessary to press the priming bulb.

4. Place your left hand on the carrying handle rubber grip and hold it firmly. Make sure your feet are away from the tiller tines. With your right hand, pull the starter grip lightly until you feel resistance, then pull briskly. Return the starter grip gently.

5. If the choke lever was moved to the CLOSED (🔒) position, gradually move it to the OPEN position as the engine warms up.

Allow the engine to warm up for a few minutes after starting the engine cold.

The tiller tines should not rotate with the engine idling. If there is rotation at idle, adjust the idle speed correctly before using the tiller (see page 24).

### CARRYING

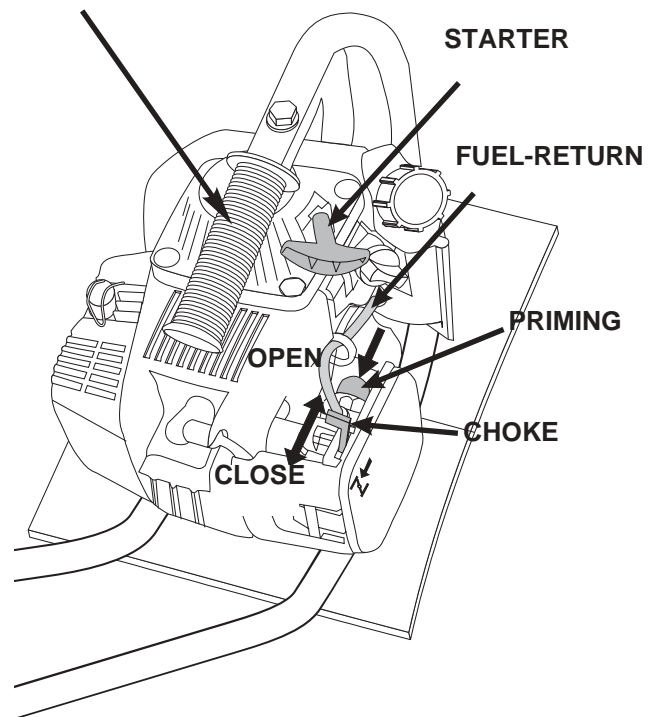

### Stopping The Engine

1. Release the throttle lever.
2. Move the engine switch to the OFF position.

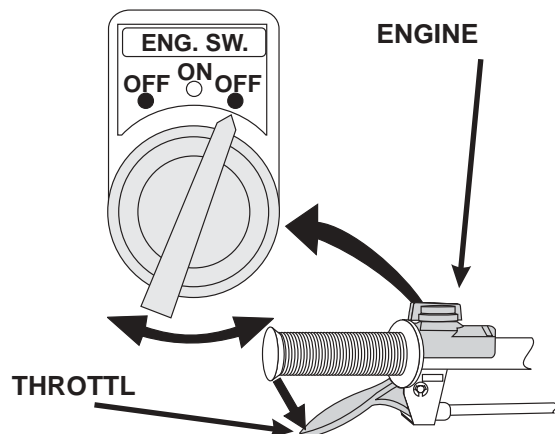

# OPERATION

---

## TILLER OPERATION

1. Install the drag bar (see page 12). Honda recommends using the drag bar when tilling. The tiller can be difficult to control without the drag bar installed.
2. Adjust the handlebar to a comfortable position around waist height for normal tilling (see page 12).
3. Set the tilling depth by moving the drag bar up or down (see page 12).

The ideal height of the drag bar will depend on the type of soil being tilled, and soil conditions at the time of tilling. In general, however, the drag bar should be adjusted so that the tiller is tilted slightly backward.

4. Start the engine (see page 13).
5. Tilt the tiller back until the tines are off the ground. Squeeze the throttle lever to full speed position (lever tight against the grip).
6. Lower the front of the tiller until the tines begin to dig into the ground.
7. Lower the handle slightly so the front of the tiller is raised about 6 - 8°. To get the maximum advantage from the tiller, hold the tiller at this angle while you are tilling the ground.

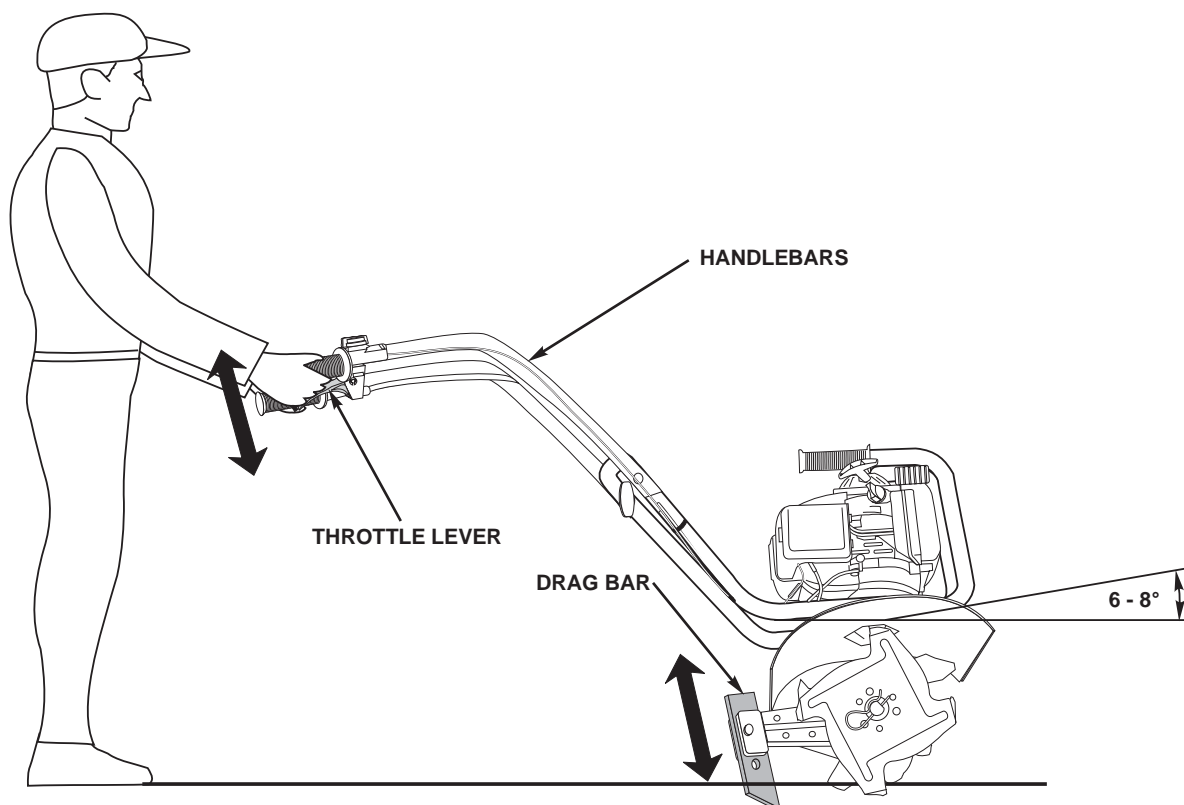

## Handling Tips

- If the tiller tends to move forward rapidly, push down on the handlebars to allow the drag bar to penetrate the soil and slow the forward motion of the tiller. Continue to press down until the tiller tines have dug to a desired depth that allows easy tiller handling.
- If the tines dig in but the tiller will not move forward, ease up on the handlebars and move the handlebars from side-to-side. If the tiller still digs in, but will not move forward, raise the drag bar up a hole.
- When turning, push down on the handlebars to bring the tiller's weight to the rear; this will make turning easier.



## Tilling In Rocky Soil

If you till in rocky soil and experience continual tine area rock jams, install the tines in the rocky soil tine configuration to help alleviate the problem.

### NOTICE

*Experiencing continual rock jams with the tines installed in the regular tine configuration, may cause transmission damage.*

1. Stop the engine (see page 13).
2. Disconnect the spark plug wire (see page 22).
3. Tip the tiller forward on the carrying handlebar as shown.
4. Remove the lock pins from the left and right tine shafts by turning them UP [a] and pulling them OUT [b].
5. Clean the tine shafts.
6. Wearing heavy gloves, remove the tines. Note that the tine sets are stamped "A", "B", "C", and "D" just inside the raised inner area of the tine set.
7. Reinstall the tine sets in the rocky soil tine configuration. When reinstalling the tines, make sure the tine shaft and tine hubs are clean and free of foreign material. The tines should easily slide onto the shaft. Do not force the tines onto the shaft.
8. Install each lock pin through the round side of the tine shaft hole [a], then turn it over [b] to lock it in place.

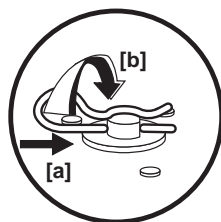
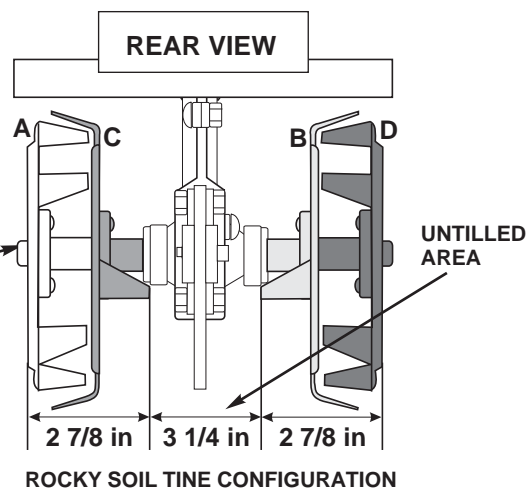
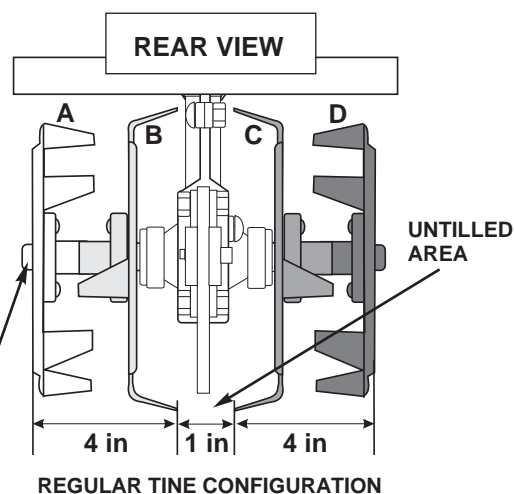
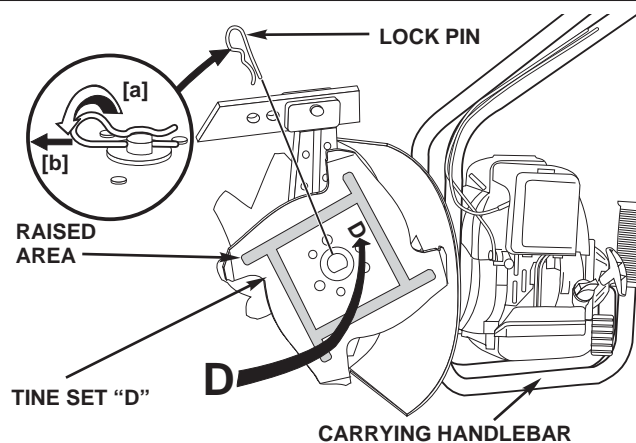

The rocky soil tine configuration has a wider center untilled area than the regular tine configuration. This will require additional passes to till the area.

When the tines are properly mounted, the angled portions of the tine blade should enter the soil first, not the straight portions.

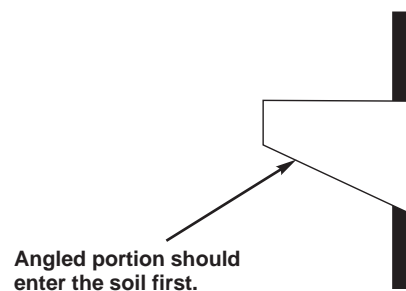

# OPERATION

---

## Narrow Cultivating

The two outer tines can be removed to give you a narrower cultivating width. This width is approximately 6 inches. This will give you the ability to get between very closely spaced plants.

In order to do this, pull the lock pin out of the hole in the end of the tine shaft. Slide the outside tine set off the tine shaft and place a tine spacer, included with your tiller, over the tine shaft. Repeat this procedure for the other side. Secure the spacer with the lock pin in the outer hole.

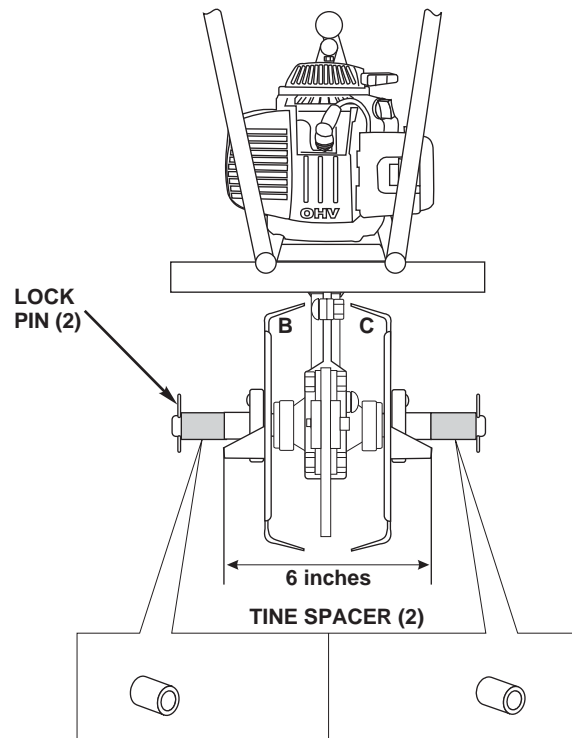

## SERVICING YOUR HONDA TILLER

### THE IMPORTANCE OF MAINTENANCE

Good maintenance is essential for safe, economical, and trouble-free operation. It will also help reduce air pollution.

#### WARNING

Improperly maintaining this tiller, or failure to correct a problem before operation, can cause a malfunction in which you can be seriously hurt or killed.

Always follow the inspection and maintenance recommendations and schedules in this owner's manual.

To help you properly care for your tiller, the following pages include a maintenance schedule, routine inspection procedures, and simple maintenance procedures using basic hand tools. Other service tasks that are more difficult, or require special tools, are best handled by professionals and are normally performed by a Honda technician or other qualified mechanic.

The maintenance schedule applies to normal operating conditions. If you operate your tiller under severe conditions, such as sustained high-load or high-temperature operation, or use it in unusually wet or dusty conditions, consult your servicing dealer for recommendations applicable to your individual needs and use.

Remember that your servicing dealer knows your tiller best and is fully equipped to maintain and repair it.

To ensure the best quality and reliability, use only new, genuine Honda parts or their equivalents for repair and replacement.

**Maintenance, replacement, or repair of the emission control devices and systems may be performed by any engine repair establishment or individual, using parts that are "certified" to EPA standards.**

### MAINTENANCE SAFETY

Some of the most important safety precautions follow. However, we cannot warn you of every conceivable hazard that can arise in performing maintenance. Only you can decide whether or not you should perform a given task.

#### WARNING

Failure to properly follow maintenance instructions and precautions can cause you to be seriously hurt or killed.

Always follow the procedures and precautions in the owner's manual.

### Safety Precautions

- Make sure the engine is off before you begin any maintenance or repairs. This will eliminate several potential hazards:
  - Carbon monoxide poisoning from engine exhaust.  
Be sure there is adequate ventilation whenever you operate the engine.
  - Burns from hot parts.  
Let the engine and exhaust system cool before touching.
  - Injury from moving parts.  
Do not run the engine unless instructed to do so.
- Read the instructions before you begin, and make sure you have the tools and skills required.
- To reduce the possibility of fire or explosion, be careful when working around gasoline. Use only a nonflammable solvent, not gasoline, to clean parts. Keep cigarettes, sparks, and flames away from all fuel-related parts.

# MAINTENANCE & ADJUSTMENTS

## MAINTENANCE SCHEDULE

REGULAR SERVICE PERIOD (3)			Before Each Use	First month or 10 Hrs	Every month or 10 Hrs	Every 3 months or 25 Hrs	Every 6 months or 50 Hrs	Every year or 100 Hrs	Every 2 years or 200 Hrs	Refer to page number
ITEM	Perform at every indicated interval									
• Engine Oil	Check		○							19
	Change			○			○			19
• Air Filter	Check		○							20
	Clean				○ (1)					21
• Spark Plug	Check-Clean								○	21
Throttle Cable	Check		○							24
Cooling Fins	Check		○				○			24
Spark Arrester	Clean							○		23
• Fuel Tank	Clean							○		26
• Fuel Filter	Check							○		26
Clutch Shoes	Check						○ (2)			-
• Idle Speed	Check-Adjust								○ (2)	24
• Valve Clearance	Change-Adjust								○ (2)	-
Nuts and Bolts	Check (Retighten if necessary)		○							-
Transmission Grease	Check					○				27
• Fuel Tubes	Check								○ (2)	26

- Emission-related items.

(1) Service after every refueling when used in extreme dusty conditions.

(2) These items should be serviced by your servicing dealer, unless you have the proper tools and are mechanically proficient. Refer to the Honda shop manual for service procedures.

(3) Log hours of operation to determine proper maintenance intervals.

## Engine Oil Level Check

Check the engine oil level before each use, or every 10 hours if operated continuously. Tip the tiller on its carrying handle, on a level surface, with the engine stopped and in an upright position.

1. Tip the tiller on its carrying handle as shown.
2. Remove the oil filler cap/dipstick and wipe it clean.
3. Insert and remove the dipstick without screwing it into the filler opening. Check the oil level shown on the dipstick.
4. If the oil level is low, fill to the edge of the oil filler hole with the recommended oil (see page 20). To avoid overfilling or underfilling, be sure the engine is in a level position, as shown.

### NOTICE

Running the engine with too little or too much oil can cause engine damage.

5. Screw in the oil filler cap/dipstick securely.

## Engine Oil Change

Drain the used oil while the engine is warm. Warm oil drains quickly and completely.

1. Tip the tiller on its carrying handle.
2. Place a suitable container below the engine to catch the used oil, then remove the oil filler cap/dipstick. Grasp the tiller as shown and tip it to drain the used oil through the oil filler opening. Allow the used oil to drain completely.

### NOTICE

Improper disposal of engine oil can be harmful to the environment. If you change your own oil, please dispose of the used oil properly. Put it in a sealed container, and take it to a recycling center. Do not discard it in a trash bin or dump it on the ground.

3. With the engine resting on the carrying handle on a level surface, fill to the edge of the oil filler hole with the recommended oil (see page 20). Do not overfill.

Engine oil capacity: **0.11 US qt (3.4 fl oz, 0.1 ℓ)**

4. Screw in the oil filler cap/dipstick securely.

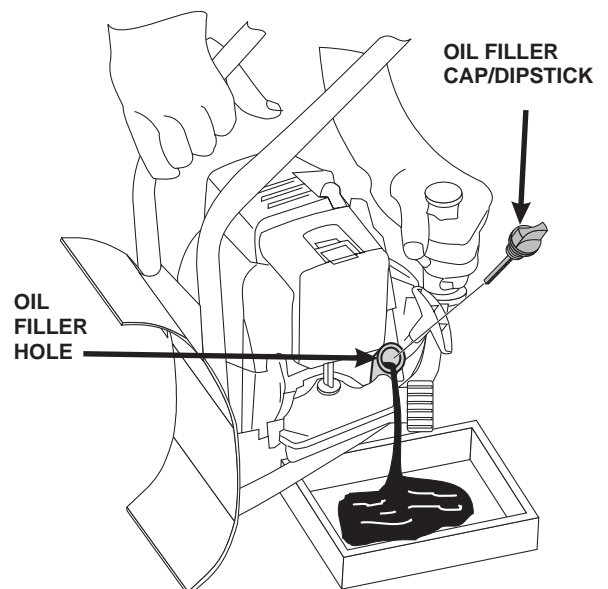
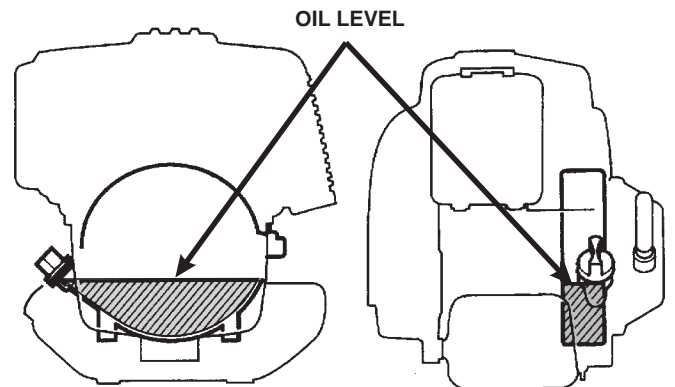
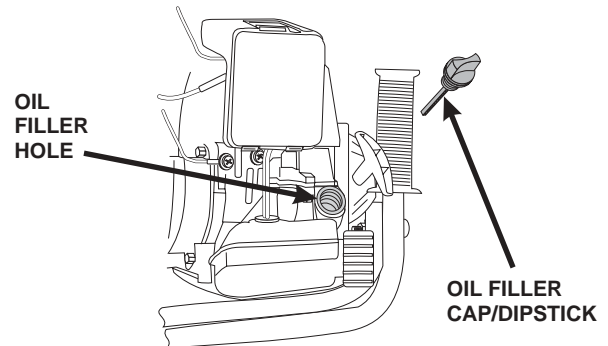
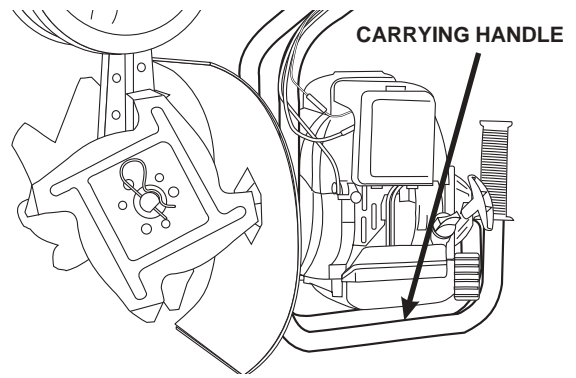

# MAINTENANCE & ADJUSTMENTS

## Engine Oil Recommendations

Oil is a major factor affecting performance and service life. Use 4-stroke automotive detergent oil.

SAE 10W-30 is recommended for general use. Other viscosities shown in the chart may be used when the average temperature in your area is within the recommended ranges.

The SAE oil viscosity and service classification are in the API label on the oil container. Honda recommends that you use API SERVICE category SH or SJ oil with the “starburst” certification mark displayed on the container.

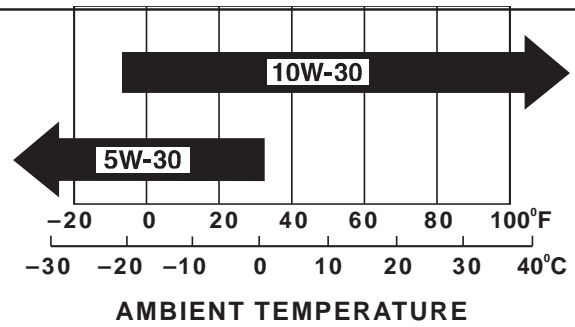

## Air Filter Inspection

1. Move the choke lever to the CHOKE (N) position to prevent dirt from entering the engine.
2. Press the air cleaner latch tab, and remove the air cleaner cover. Check the air filter to be sure it is clean and in good condition.
3. If the air filter is dirty, clean it as described under Air Filter Cleaning (see page 21). Replace the air filter if it is damaged.

### NOTICE

Operating the engine without an air filter, or with a damaged air filter, will allow dirt to enter the engine, causing rapid engine wear. This type of damage is not covered by the Distributor's Limited Warranty.

4. Align the air filter with the air filter base as shown. Reinstall the air filter by locating the five air cleaner base pegs into the five air filter holes. Slide the air filter over the pegs until it is flush with the air cleaner base.

### NOTICE

An improperly installed air filter will allow dirt to enter the engine, causing rapid engine wear. Make sure the air filter is properly installed and flush with the air cleaner base before installing the air cleaner cover.

5. Reinstall the air cleaner cover by hooking the retaining tabs and snapping the latch tab into place.

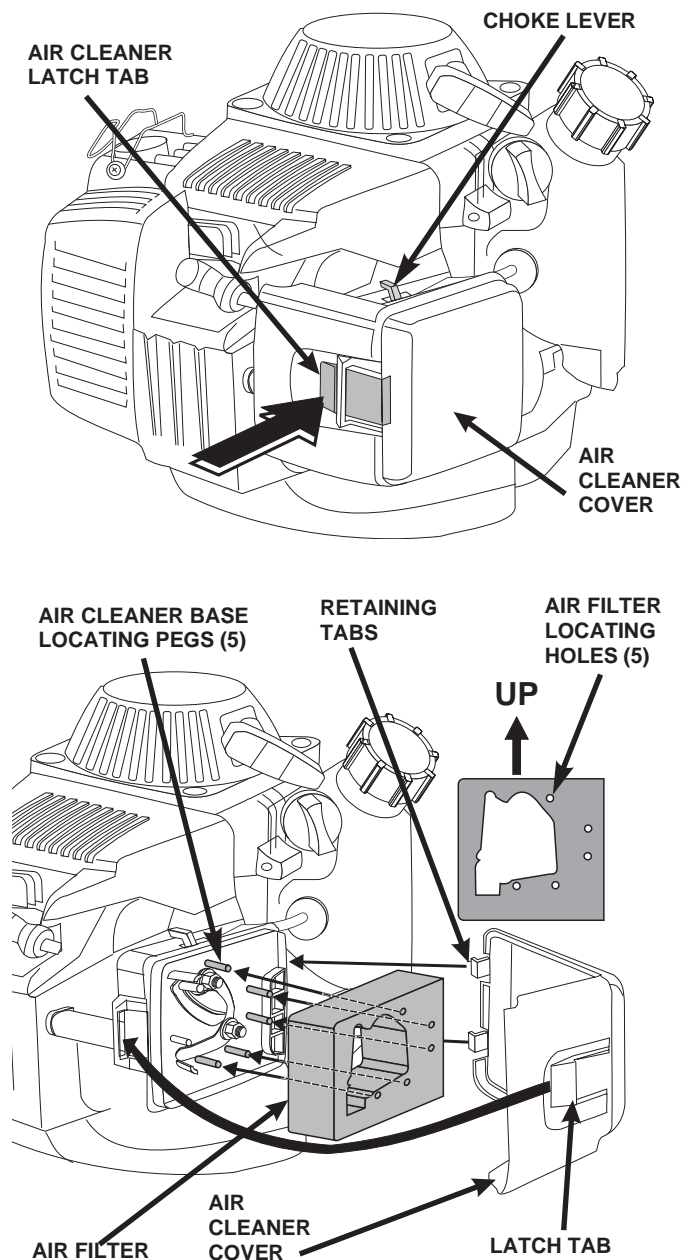

## Air Filter Cleaning

A dirty air filter restricts air flow to the carburetor, reducing engine performance. If you operate the engine in very dusty areas, clean the air filter after each refueling.

1. Remove the air filter (see page 20).
2. Clean the air filter in warm soapy water, rinse, and allow to dry thoroughly. Or, clean in nonflammable solvent and allow to dry.
3. Dip the air filter in clean engine oil, then squeeze out all excess oil. The engine will smoke when started if too much oil is left in the air filter.

### NOTICE

Operating the engine with a dry air filter will allow dust to enter causing engine damage. The air filter must be oiled after cleaning.

4. Wipe dirt from the air cleaner base and cover using a moist rag. Be careful to prevent dirt from entering the carburetor.
5. Reinstall the air filter and air filter cover (see page 20).

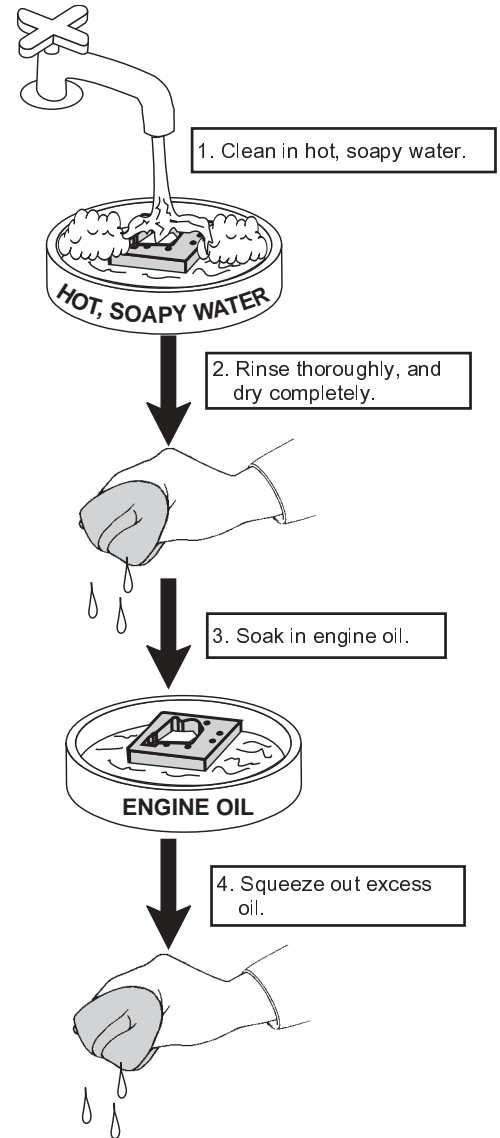

## MAINTENANCE & ADJUSTMENTS

### Spark Plug Service

Recommended spark plugs:  
C5HSB or CR5HSB (NGK)  
U16FS-UB or U16FSR-UB (DENSO)

#### NOTICE

Incorrect spark plugs can cause engine damage.

1. Disconnect the spark plug cap, and remove any dirt from around the spark plug area.
2. Remove the spark plug with a 5/8-inch spark plug wrench.
3. Inspect the spark plug. Replace it if the electrodes are worn, or if the insulator is cracked or chipped. Clean the spark plug with a wire brush if you are going to reuse it.
4. Measure the spark plug electrode gap with a suitable gauge. The gap should be:  
**0.024 - 0.028 in (0.60 - 0.70 mm).**

Correct the gap, if necessary, by carefully bending the side electrode.

5. Install the spark plug carefully, by hand, to avoid cross-threading.
6. After the spark plug seats, tighten with a 5/8-inch spark plug wrench to compress the washer.

If reinstalling the used spark plug, tighten 1/8 - 1/4 turn after the spark plug seats.  
If installing a new spark plug, tighten 1/2 turn after the spark plug seats.

#### NOTICE

A loose spark plug can overheat and damage the engine. Overtightening the spark plug can damage the threads in the cylinder head.

7. Attach the spark plug cap.

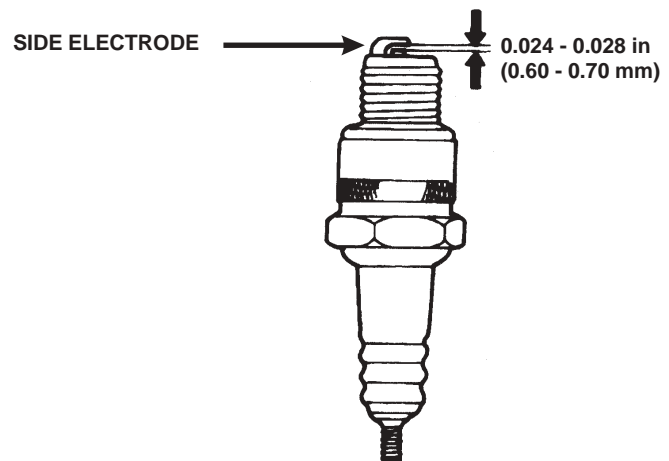
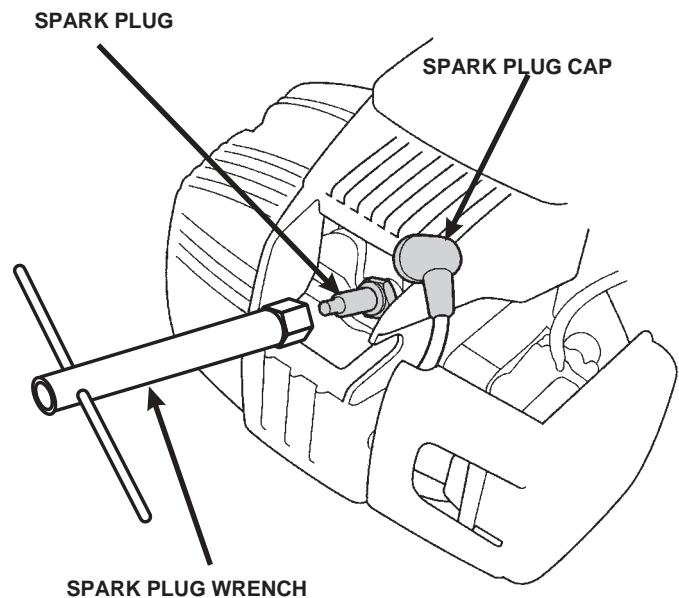



## Spark Arrester Service

The spark arrester must be serviced every 100 hours to keep it functioning as designed.

If the engine has been running, the muffler will be very hot. Allow the muffler to cool before servicing the spark arrester.

1. Remove the four 5 x 18 mm bolts from the recoil starter, and remove the recoil starter.
2. Disconnect the spark plug cap from the spark plug. Pull the spark plug wire and the ignition switch wire out of the retainers in the top cover.
3. Remove the two 5 x 22 mm bolts from the top cover, and remove the top cover.
4. Remove the three 5 mm screws from the muffler cover, and remove the muffler cover.
5. Remove the special screw from the exhaust deflector, and remove the exhaust deflector.
6. Remove the special screw from the spark arrester, and remove the spark arrester.
7. Use a brush to remove carbon deposits from the spark arrester screen. Be careful to avoid damaging the screen.

The spark arrester must be free of breaks and holes. Replace the spark arrester if it is damaged.

8. Install the spark arrester, muffler cover, top cover, and recoil starter in the reverse order of disassembly.

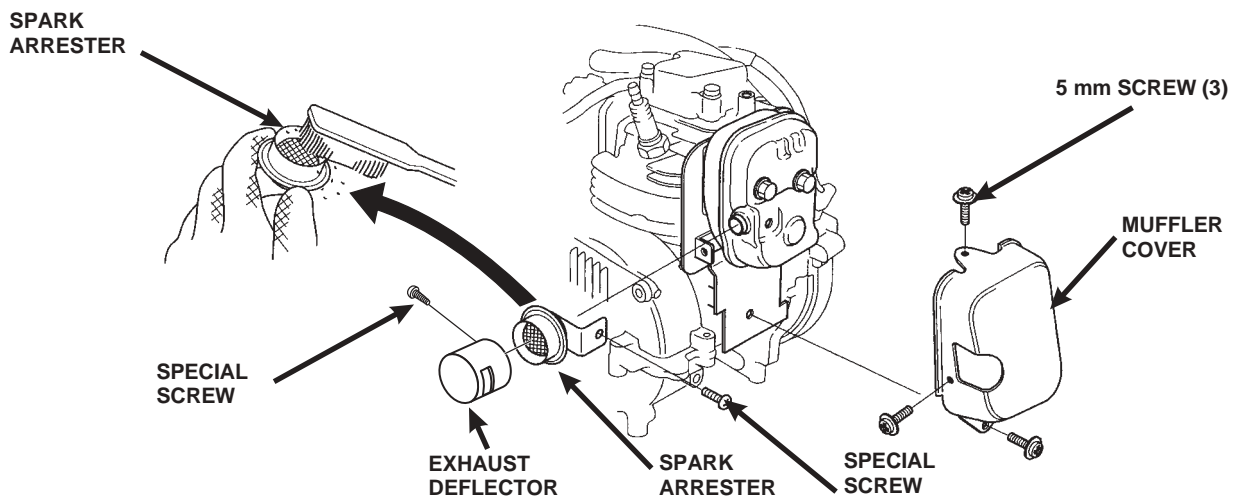
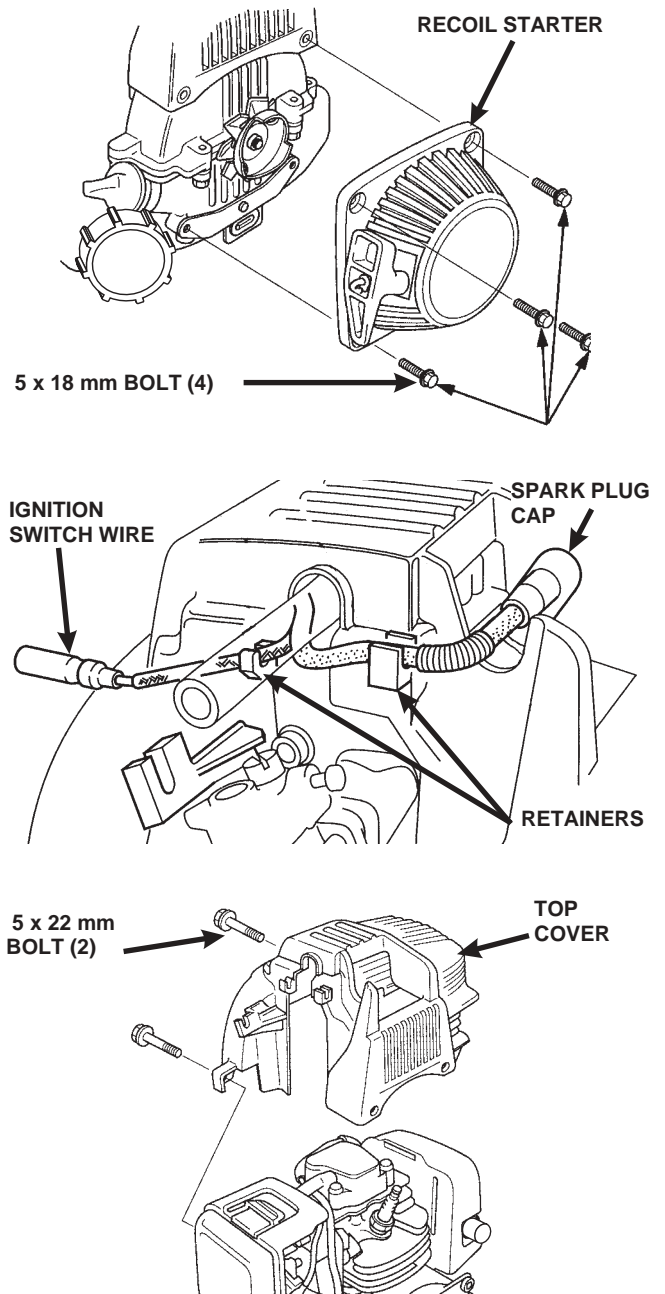

## MAINTENANCE & ADJUSTMENTS

### Cooling Fin Inspection

Inspect the engine cooling fins. Clean out any dirt and debris if the air flow is obstructed from flowing across the cooling fins.

If it is necessary to remove the top cover for better access to the cooling fins, follow the disassembly steps 1 through 3 on page 23.

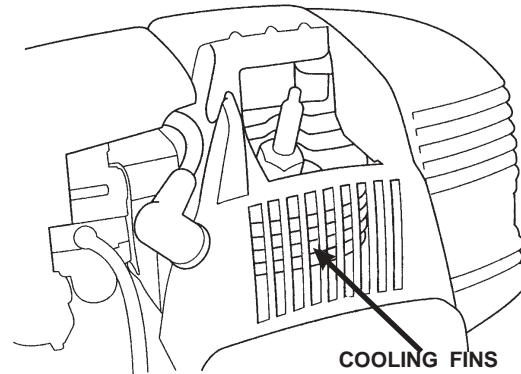

### Throttle Cable Inspection

Verify that the throttle trigger operates smoothly, and the throttle cable is undamaged. If there is visible damage, or if the throttle trigger does not operate smoothly, have your Honda servicing dealer replace the throttle cable.

Check the free play at the end of the throttle lever. Free play should be: **1/8 - 1/16-inch (3 - 5 mm)**.

If adjustment is needed, use the following cable adjustment procedure.

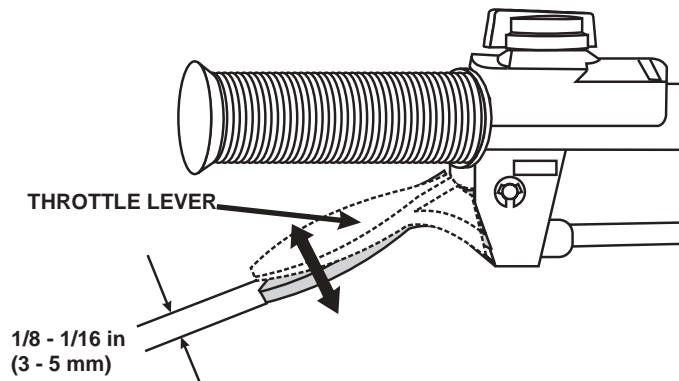

### Throttle Cable Adjustment

1. Loosen the lock nuts with a 10 mm wrench, and move the adjuster in or out as required.  
Throttle Lever Free Play:  
**1/8 - 1/16 inch (3 - 5 mm)**.
2. Tighten the lock nuts and recheck throttle lever free play.

### Idle Speed Adjustment

1. Verify that throttle lever free play is:  
**1/8 - 1/16 inch (3 - 5 mm)**
2. Start the engine outdoors, and allow it to warm up to normal operating temperature.
3. Turn the throttle stop screw to obtain a stable idle, below the speed at which the tiller tines begin to turn.  
**Standard idle speed: 3,100 ± 200 rpm.**

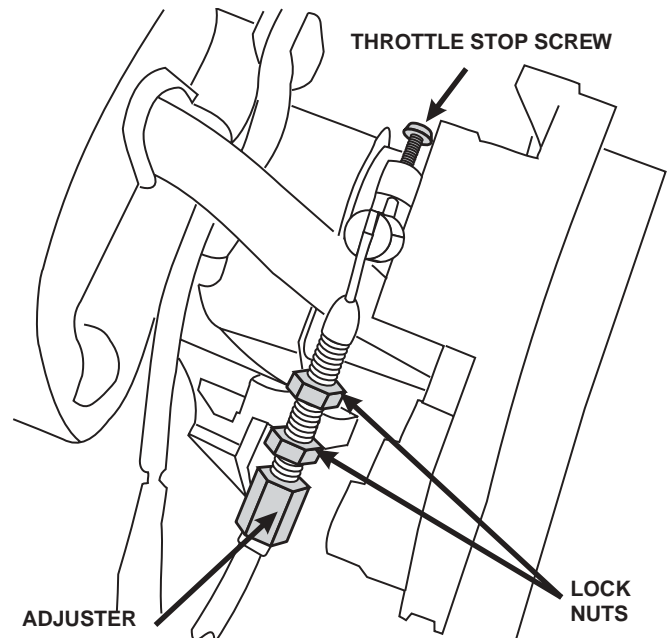

## FUEL SYSTEM

### Refueling

Fuel Tank Capacity: **0.75 US qt (1.5 US pt, 0.7 ℓ)**

Check the fuel level by looking through the translucent fuel tank.

If the fuel level is low, refuel in a well-ventilated area with the engine stopped. If the engine has been running, allow it to cool first.

To refuel, set the tiller on level ground. Remove the fuel tank cap, and fill the tank with gasoline to the bottom of the filler neck. Refuel carefully to avoid spilling fuel. Do not overfill. There should not be fuel in the filler neck. After refueling, tighten the fuel tank cap securely.

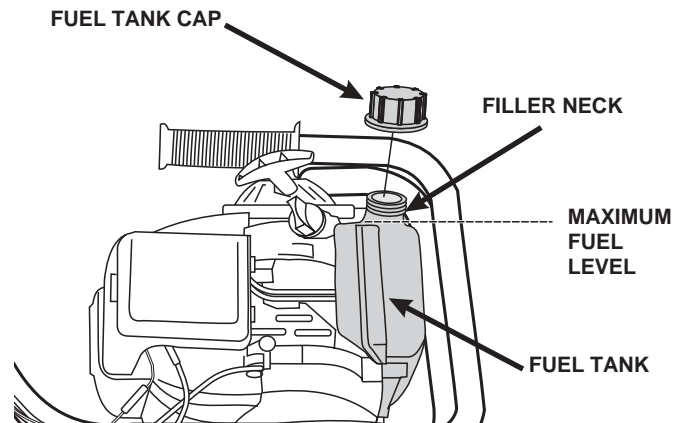

### Fuel Recommendations

Use unleaded gasoline with a pump octane rating of 86 or higher.

This engine is certified to operate on unleaded gasoline. Unleaded gasoline produces fewer engine and spark plug deposits and extends exhaust system life.

Never use stale or contaminated gasoline or an oil/gasoline mixture. Avoid getting dirt or water in the fuel tank.

Occasionally you may hear a light “spark knock” or “pinging” (metallic rapping noise) while operating under heavy loads. This is no cause for concern.

If spark knock or pinging occurs at a steady engine speed, under normal load, change brands of gasoline. If spark knock or pinging persists, see an authorized Honda servicing dealer.

### WARNING

Gasoline is highly flammable and explosive.

You can be burned or seriously injured when handling fuel.

- Stop the engine and keep heat, sparks, and flames away.
- Handle fuel only outdoors.
- Wipe up spills immediately.

Never refuel the engine inside a building where gasoline fumes may reach flames or sparks. Keep gasoline away from appliance pilot lights, barbecues, electric appliances, power tools, etc.

Spilled fuel is not only a fire hazard, it causes environmental damage. Wipe up spills immediately.

Move at least 10 feet (3 meters) away from the fueling source and site before starting the engine.

### NOTICE

Fuel can damage paint and plastic. Be careful not to spill fuel when filling your fuel tank. Damage caused by spilled fuel is not covered under warranty.

### NOTICE

Running the engine with persistent spark knock or pinging can cause engine damage.

Running the engine with persistent spark knock or pinging is misuse, and the Distributor's Limited Warranty does not cover parts damaged by misuse.

# MAINTENANCE & ADJUSTMENTS

## Fuel Tube Inspection

Check the fuel supply and return tubes, and replace any tube that is damaged, cracked, or leaking.

Refer to the Honda shop manual for tube replacement instructions, or take the tiller to a Honda servicing dealer.

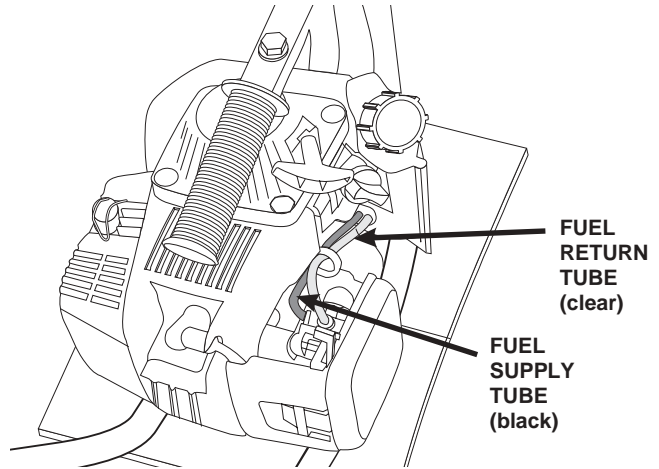

## Fuel Filter and Fuel Tank Cleaning

1. Remove the fuel tank cap.
2. Tip the tiller as shown and empty the fuel tank into an approved gasoline container. Use a funnel to avoid spilling gasoline.
3. Pull the fuel filter out through the fuel filler neck by hooking the black fuel supply tube with a piece of wire, such as a partly straightened paper clip.
4. Inspect the fuel filter. If the fuel filter is dirty, wash it with nonflammable solvent. Be careful to avoid damaging the filter.
5. Replace the filter if it is damaged or excessively dirty.
6. Rinse sediment from the fuel tank with nonflammable solvent.
7. Insert the fuel filter in the fuel tank, and install the fuel tank cap.

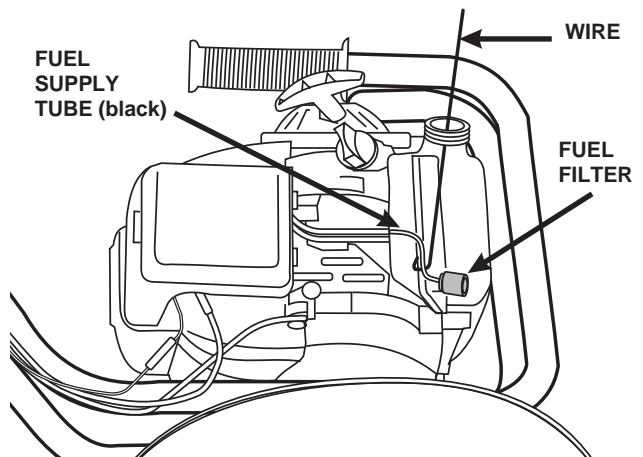
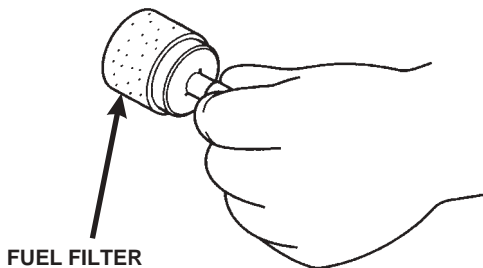
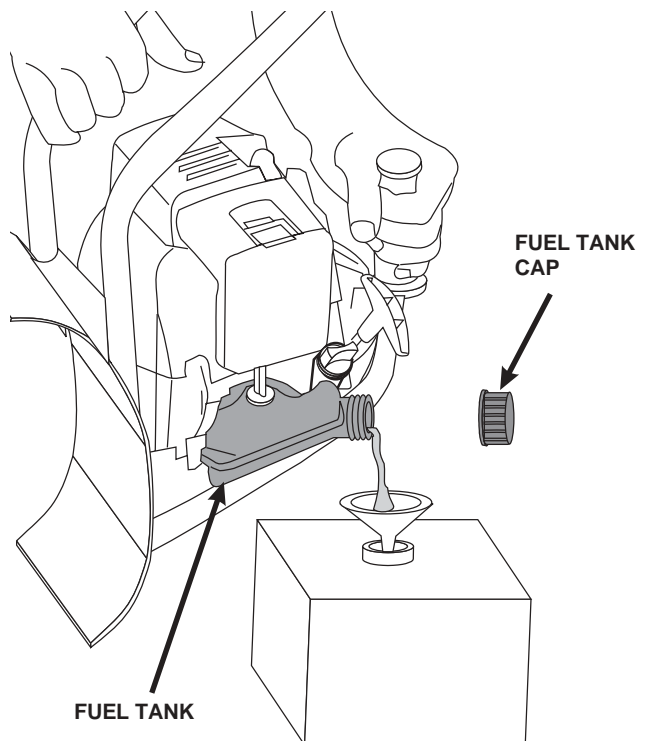

## Transmission Lubrication

The transmission is pre-lubricated at the factory.

At the beginning of each tilling season, or after every 25 hours of use during the season, the transmission should be filled with grease.

Replacement grease should be a high quality petroleum based NLGI #2 general purpose grease usually available in disposable guns at most hardware or automotive parts stores.

1. Place the tiller on the carrying handle (see page 19).
2. Remove the lock pin from the right side tine shaft by turning it UP [a] and pulling it out [b] as shown. Wearing heavy gloves, remove both right side tines.
3. Remove the dust cap.
 

The metal dust cap is held on with a set screw. Loosen the set screw using a 3/32 inch allen wrench. The dust cap should then slide off of the tine shaft.
4. Lay the tiller on its left side so that the tine shaft is vertical.
5. Remove the air vent screw and fill hole screw from the transmission.
6. Fill the transmission by using a grease gun or grease applicator at the fill hole screw opening. Push the gun or applicator against the opening so as to "seal" the nozzle of the gun or applicator against the casting embossment. Apply grease until grease begins to come out of the top air vent hole.
7. Reinstall the air vent screw and fill hole screw.
8. Reinstall the dust cap and tighten the set screw.
9. Place a few drops of oil on the tine shaft before installing the tines.
10. Wear heavy gloves and reinstall the tines in the reverse order of removal.
11. Install the lock pin through the round side of the tine shaft hole [a], then turn it over [b] to lock it in place.

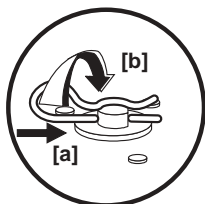
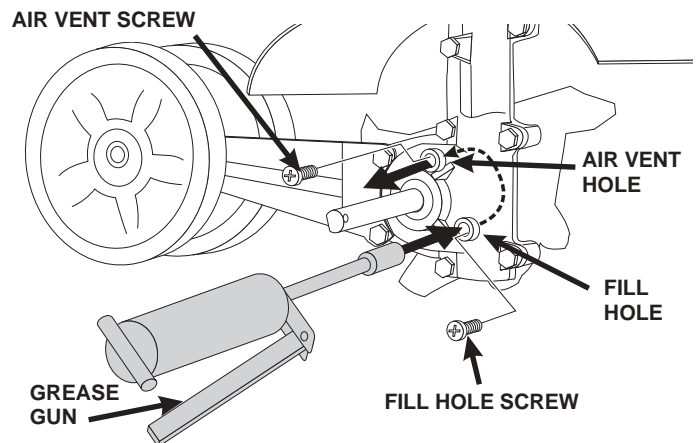
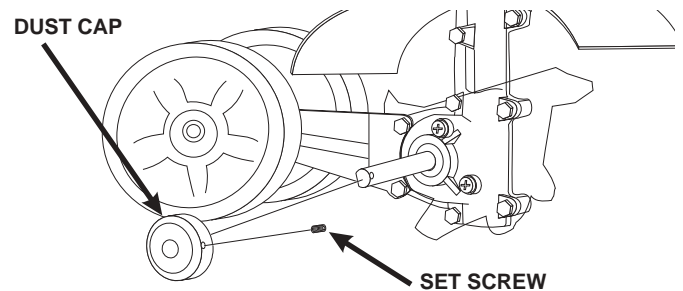
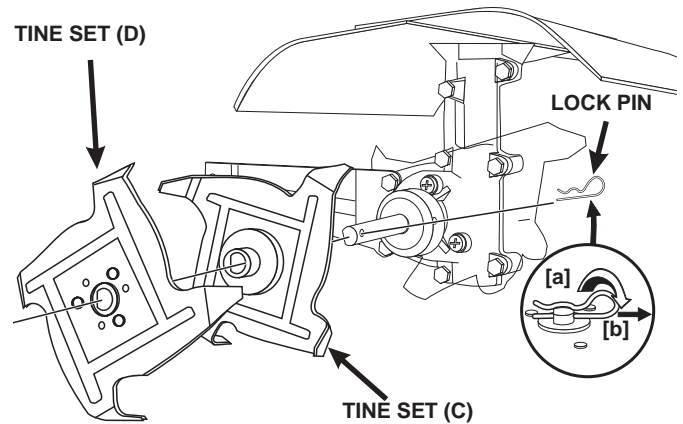

## THE IMPORTANCE OF PROPER ASSEMBLY

Proper assembly is essential to operator safety and the reliability of the machine. Any error or oversight made by the person assembling and servicing a unit can easily result in faulty operation, damage to the machine, or injury to the operator.

### **WARNING**

Improper assembly can cause an unsafe condition that can lead to serious injury or death.

Follow the procedures and precautions in the assembly instructions carefully.

Some of the most important safety precautions are given below. However, we cannot warn you of every conceivable hazard that can arise in performing this assembly. Only you can decide whether or not you should perform a given task.

### **WARNING**

Failure to properly follow instructions and precautions can cause you to be seriously hurt or killed.

Follow the procedures and precautions in this manual carefully.

## IMPORTANT SAFETY PRECAUTIONS

- Make sure you have a clear understanding of all basic shop safety practices and that you are wearing appropriate clothing and safety equipment. When performing this assembly, be especially careful of the following:
  - Read the instructions before you begin and be sure you have the tools and skills required to perform the tasks safely.
- Make sure the engine is off before you begin any maintenance or repairs. This will help eliminate several potential hazards:
  - Carbon monoxide poisoning from engine exhaust.**  
Be sure there is adequate ventilation whenever you run the engine.
  - Burns from hot parts.**  
Let the engine and exhaust system cool before touching.
  - Injury from moving parts.**  
Do not run the engine unless the instruction tells you to do so. Even then, keep your hands, fingers, and clothing away. Do not run the engine when any protective guard or shield is removed.
- To reduce the possibility of a fire or explosion, be careful when working around gasoline or batteries. Use only a nonflammable solvent, not gasoline, to clean parts. Keep all cigarettes, sparks, and flames away from all fuel-related parts.

**UNPACKING**

1. Carefully remove the tiller and loose parts from the carton.
2. Remove the loose parts bag. Compare the loose parts with the inventory list below.

**Tools Required:**

Phillips screwdriver, 7/16 inch wrench (2), and 3/8 inch wrench.

**LOOSE PARTS**

Check all loose parts against the following list. Contact your your dealer if any of the loose parts shown below are not included with your tiller.

Ref. No	Description	Qty.
1	Upper Handle	1
2	Lower Handle, Right	1
3	Lower Handle, Left	1
4	Grip	2
5	Wheel Support	1
6	Wheel	2
7	Knob, Handlebar	2
8	1/4-20 x 4 1/2 inch Bolt	2
9	Wheel Washer	2
10	Wheel Spacer	2

Ref. No	Description	Qty.
11	Lock Pin	3
12	Clevis Pin	1
13	5/16-18 x 1 1/2 Handlebar Bolt	2
14	1/4 inch Curved Washer	8
15	1/4 inch Locking Nut	3
16	Tie Strap	2
17	1/4-20 x 2 inch Flange Bolt	1
18	Pipe Plug	1
19*	Tine Spacer	2
20**	Drag Bar	1

\* The tine spacers (item 20) are installed for narrow cultivating (see page 16).

\*\* The drag bar (item 21) is installed in place of the wheel assembly prior to tilling (see page 9).

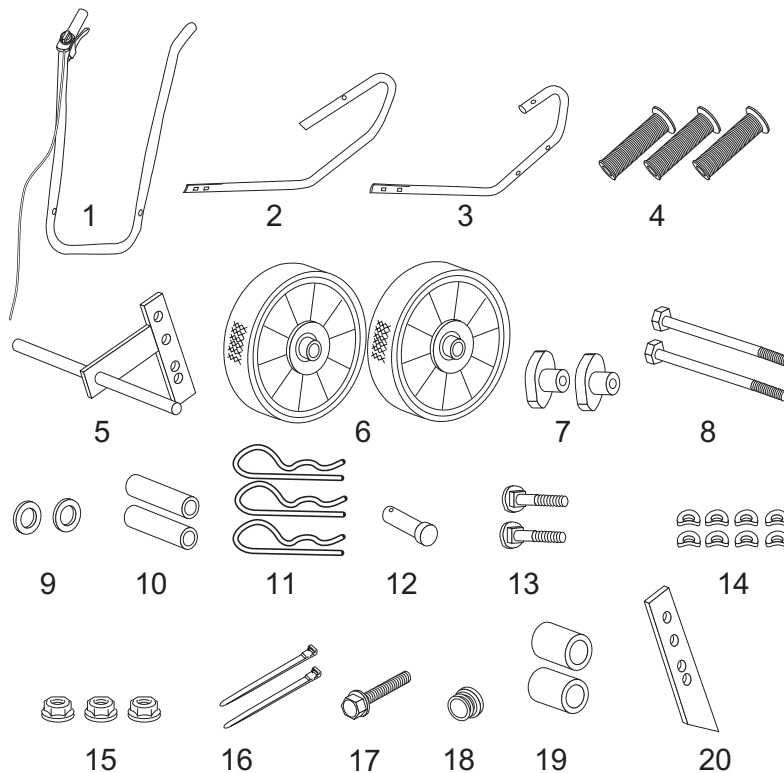

# ASSEMBLY

## TILLER ASSEMBLY

1. Install the wheel spacers on the wheel support.
2. Install the wheels on the wheel support.

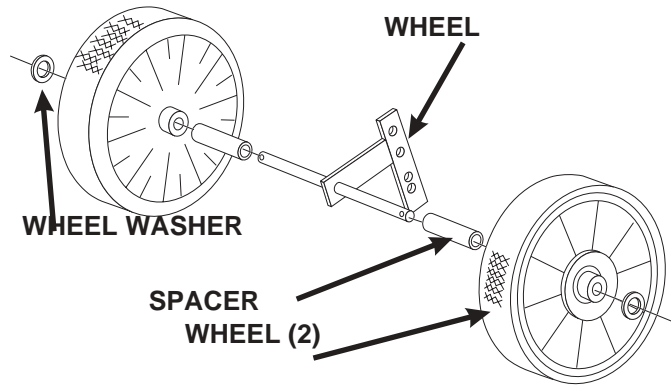

3. Retain each wheel to the wheel support with a wheel washer and lock pin.

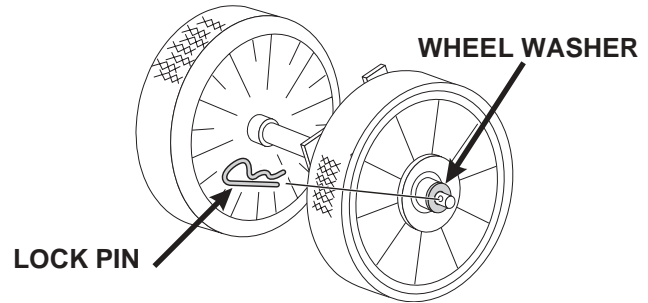

4. Install the wheel assembly to the bracket assembly using the clevis pin and a lock pin. Set the wheel height in the second hole from the top as shown. After the assembly is completed, select one of the four holes that provides the most comfort when transporting the tiller (see page 12).

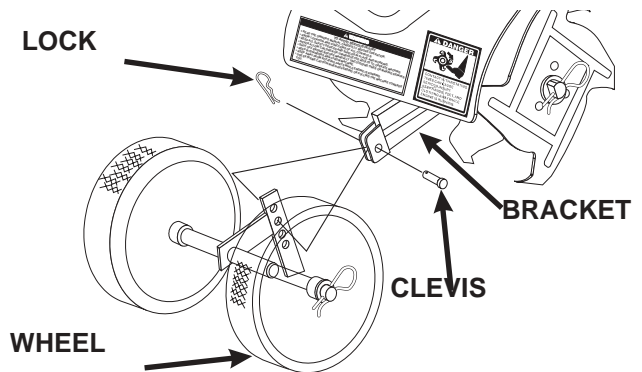

5. Install the left and right lower handles to the transmission engine mount with the two 1/4-20 x 4 1/2 inch bolts, four curved washers and two 1/4 inch locking nuts. Do not tighten the mounting bolts at this time. The left and right lower handles are identified by the different lengths from the end of the pipe to the mounting bolt hole as shown.

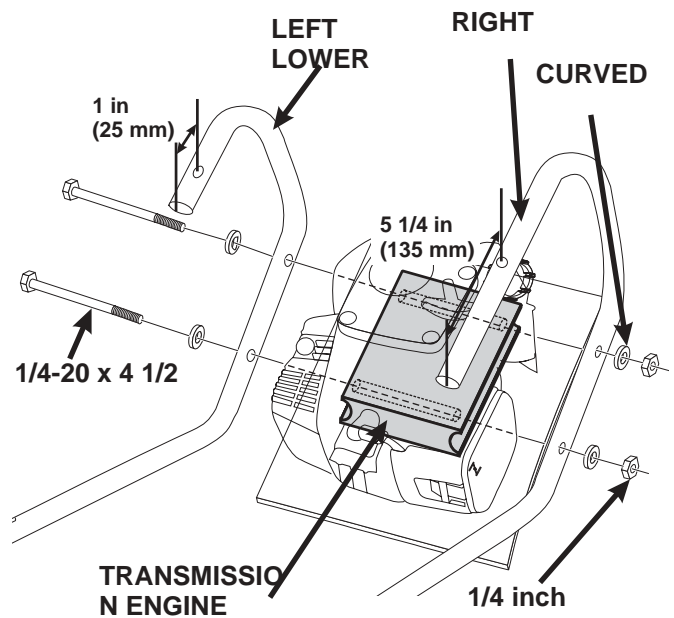



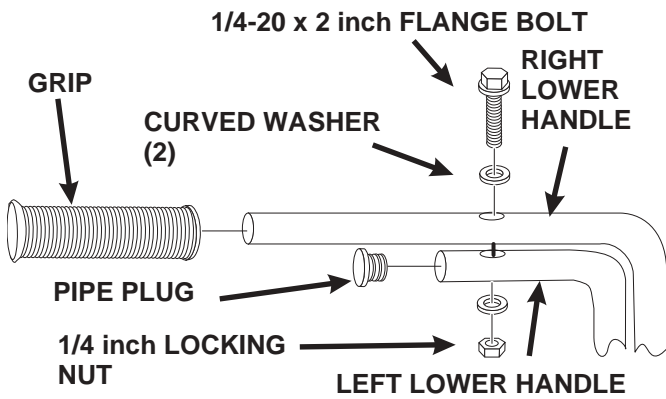

6. Install the grip on the right lower handle. Apply a small amount of dish soap to the right handle pipe to ease the installation of the grip.
7. Install the pipe plug into the left lower handle.
8. Secure the left and right lower handles using the 1/4-20 x 2 inch flange bolt, two curved washers and a 1/4 inch locking nut.
9. Securely tighten the hardware to complete the installation of the left and right handles to the tiller.

Use a torque wrench and finish tightening the hardware to: **8 ft-lb (10.8 N•m)**

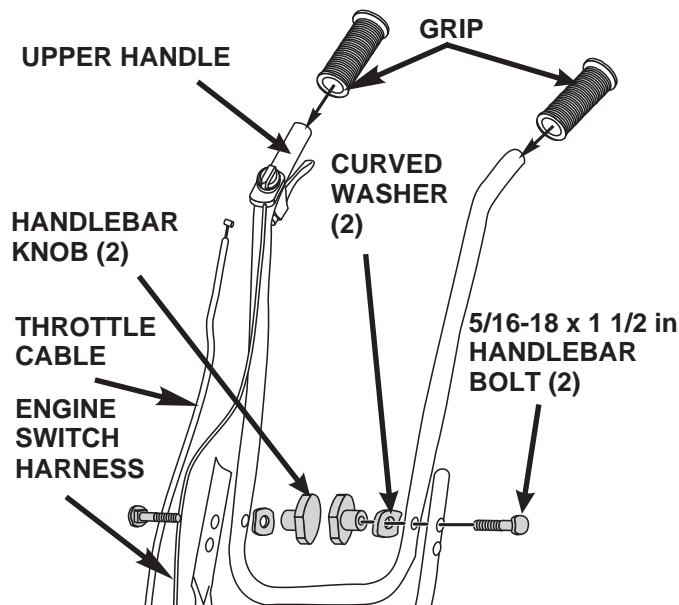

10. Install the upper handle to the lower handles using the two 5/16-18 x 1 1/2 inch curved-head bolts, two curved washers and the two handlebar knobs.

Make sure the throttle cable and engine switch harness are on the outside of the upper and lower handlebars.

11. Install the grips on the upper handle. Use a small amount of liquid dish soap on the upper handle pipe to ease grip installation.

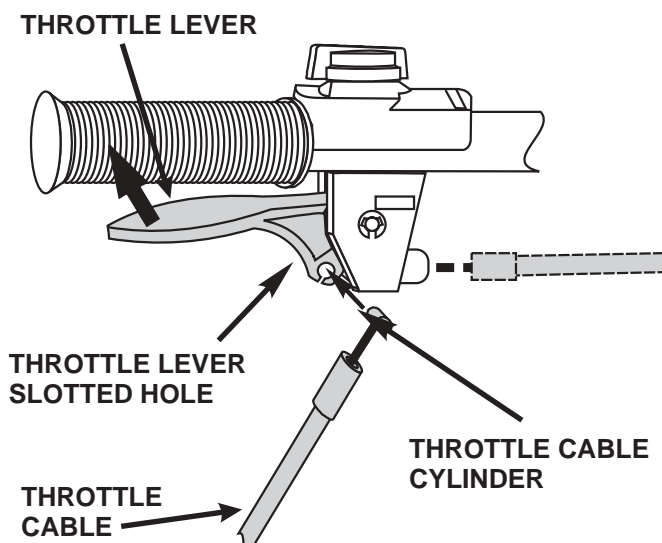

12. Lift the throttle lever towards the handlebar to expose the slotted hole.
13. Take the cylinder end of the throttle cable and insert it in the throttle lever slotted hole.

# ASSEMBLY

14. Release the throttle lever. Swing the cable up as shown. Pull on the throttle cable sheave so the ferrule end can fit into the throttle lever cable socket.

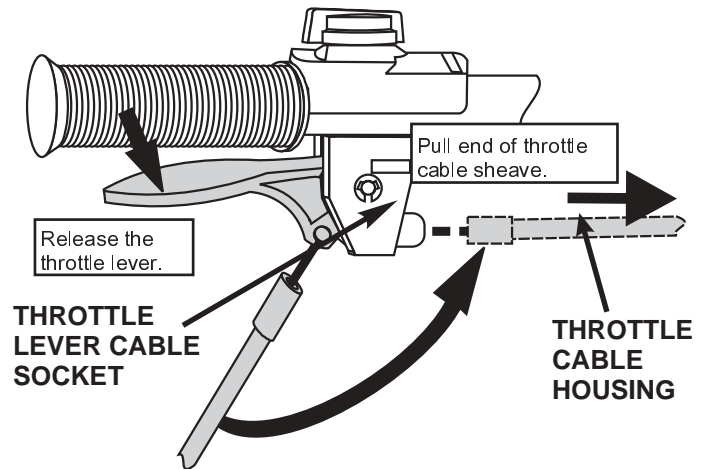

15. Release the throttle cable into the throttle lever cable socket. Squeeze the throttle lever several times to make sure it operates smoothly.

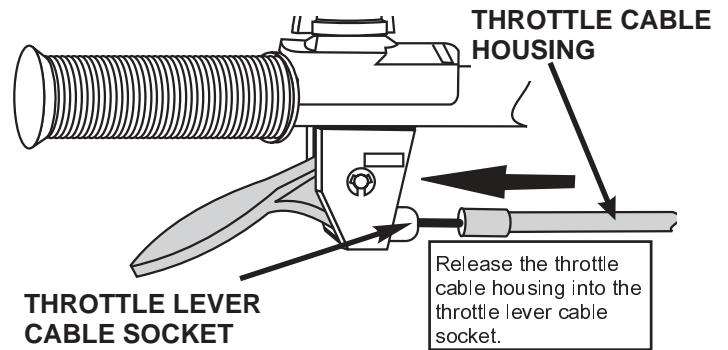

16. Remove the small screw from the engine block just below the air cleaner cover. Take the eyelet end of the green wire and secure it to the engine block with the screw.

17. Plug the male connector end of the black wire to the female connector hanging below the air cleaner cover.

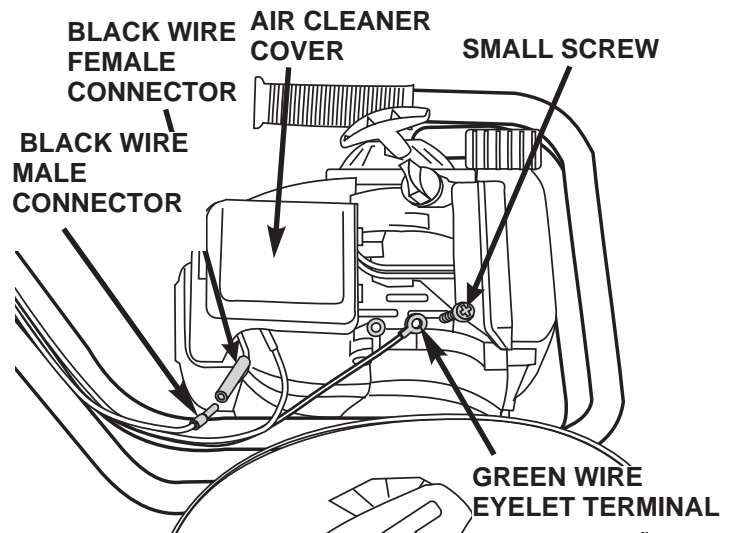

18. Secure the throttle cable and engine switch wire harness to the upper handle and right lower handle using the two tie straps as shown.

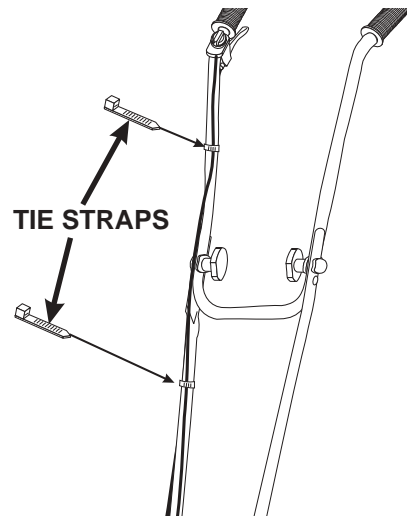

19. Tip the tiller on its carrying handle on a level surface as shown.  
20. Remove the oil filler cap/dipstick.

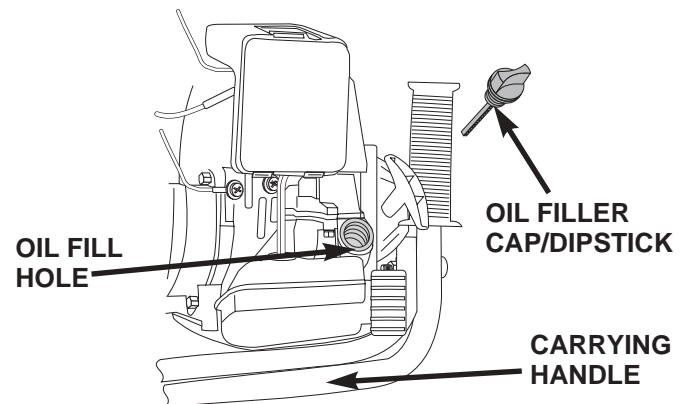

21. Slowly add the recommended oil (see page 20) to the bottom edge of the oil fill hole. Do not overfill, as the engine oil tank capacity is small.  
Engine oil capacity: **0.11 US qt (3.4 fl oz, 0.1 ℓ)**

**NOTICE**

Running the engine with too little or too much oil can cause engine damage.

22. Screw in the oil filler cap/dipstick securely.

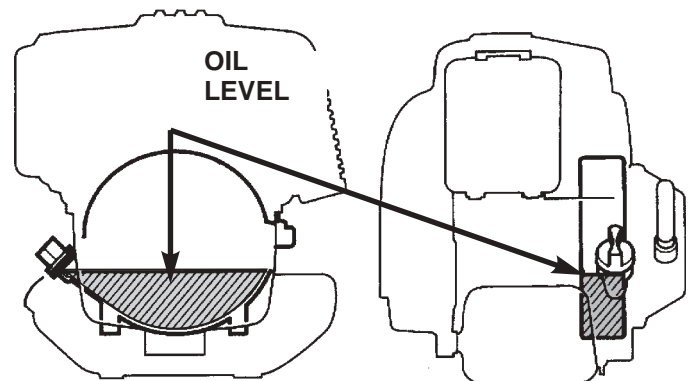

Before using the tiller, all operators of the tiller must read the following sections:

- **SAFETY** (see page 4)
- **CONTROLS** (see page 7).
- **BEFORE OPERATION** (see page 10).
- **OPERATION** (see page 12).

# TRANSPORTING/STORAGE

## TRANSPORTING

### Before Loading

Always turn the engine switch to the OFF position. Make sure the fuel cap is securely tightened.

Install the wheels to provide added stability when transporting (see page 12).

If the engine has been running, allow it to cool for at least 15 minutes before loading the tiller on the transport vehicle. A hot engine and exhaust system can burn you and can ignite some materials.

### Loading

If necessary, loosen the handle bar knobs so that the tiller upper handle can be collapsed. Be careful that the throttle cable and engine switch wire are not pinched or bent when collapsing the upper handle.

Secure the tiller by tying around the lower handles just in front and back of the engine as shown.

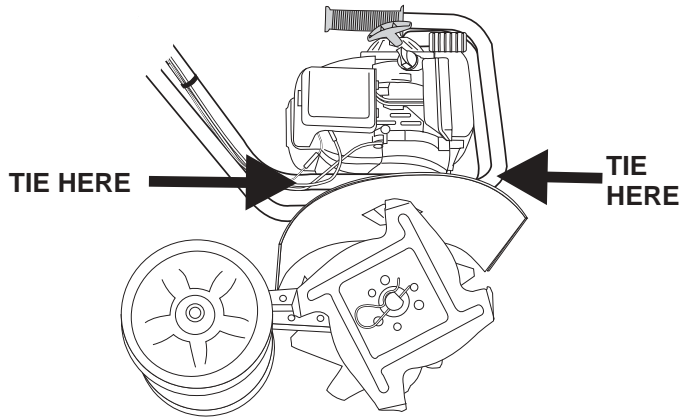
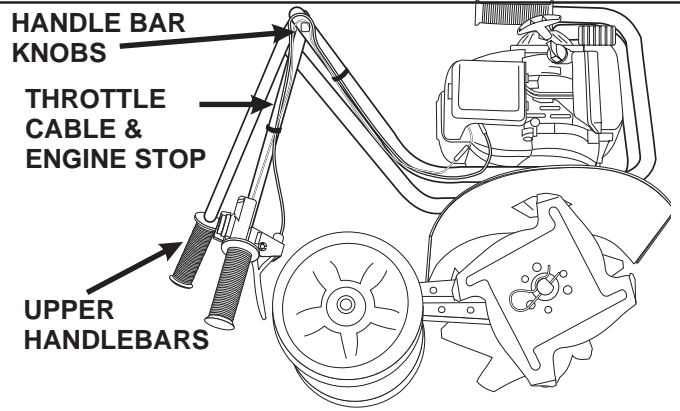

## STORAGE

Proper storage preparation is essential for keeping your tiller troublefree and looking good. The following steps will help to keep rust and corrosion from impairing your tiller's function and appearance, and will make the engine easier to start when you use the tiller again.

### Cleaning

Wash the tiller, including the area around the tiller tines.

Wash the engine by hand, and be careful to prevent water from entering the air cleaner.

#### NOTICE

Using a garden hose or pressure washing equipment can force water into the air cleaner. Water in the air cleaner will soak the filter and can enter the carburetor or engine, causing damage.

Water on a hot engine can cause damage. If the engine has been running, allow it to cool for at least 1/2 hour before washing.

If using a garden hose or pressure washing equipment to clean the tiller, be careful to avoid getting water into controls and cables, or anywhere near the engine air cleaner or muffler opening.

After washing the tiller, wipe dry all accessible surfaces.

Start the engine outdoors, and let it run until it reaches normal operating temperature to evaporate any water remaining on the engine.

Stop the engine and allow it to cool.

After the tiller is clean and dry, touch up any damaged paint, and coat other areas that may rust with a light film of oil. Lubricate the throttle cable core with a silicone spray lubricant.

## Fuel

Gasoline will oxidize and deteriorate in storage. Old gasoline will cause hard starting, and it leaves gum deposits that restrict the fuel system. If the gasoline in your tiller deteriorates during storage, you may need to have the carburetor and other fuel system components, serviced or replaced.

The length of time that gasoline can be left in your fuel tank and carburetor without causing functional problems will vary with such factors as gasoline blend, storage temperatures, and whether the fuel tank is partially or completely filled. The air in a partially filled fuel tank promotes fuel deterioration. Very warm storage temperatures accelerate fuel deterioration. Fuel deterioration problems may occur within a few months, or even less if the gasoline was not fresh when you filled the fuel tank.

The Distributors Limited Warranty does not cover fuel system damage or engine performance problems resulting from neglected storage preparation.

## Adding fuel stabilizer to extend fuel storage life

You can extend fuel storage life by adding a gasoline stabilizer that is formulated for that purpose, or you can avoid fuel deterioration problems by draining the fuel tank and carburetor.

When adding a fuel stabilizer, fill the fuel tank with fresh gasoline. If only partially filled, air in the tank will promote fuel deterioration during storage. If you keep a container of gasoline for refueling, be sure that it contains only fresh gasoline. Add fuel stabilizer following the manufacturer's instructions.

After adding a fuel stabilizer, run the engine outdoors for 10 minutes to be sure that treated gasoline has replaced the untreated gasoline in the carburetor.

## Draining the Fuel Tank and Carburetor

Drain the fuel from the fuel tank to a suitable container (see page 26).

Start the engine (see page 13) and allow it to run until the engine stops.

### **WARNING**

Gasoline is highly flammable and explosive.

You can be burned or seriously injured when handling fuel.

- Stop the engine and keep heat, sparks, and flames away.
- Handle fuel only outdoors.
- Wipe up spills immediately.

## Engine Oil

Change the engine oil (see page 19).

## Carburetor & Air Cleaner

Clean the air filter (see page 21) and move the choke lever to the CLOSED (E) position.

## Engine Cylinder

Remove the spark plug (see page 22). Pour a 1/4 tablespoon (1 ~ 3 cc) of clean engine oil into the cylinder. Pull the starter rope several times to distribute the oil in the cylinder. Reinstall the spark plug. Pull the starter rope slowly until resistance is felt then return the starter grip gently. This closes the valves so moisture cannot enter.

## TRANSPORTING/STORAGE

---

### STORAGE PRECAUTIONS

If your tiller will be stored with gasoline in the fuel tank and carburetor, it is important to reduce the hazard of gasoline vapor ignition. Select a well-ventilated storage area away from any appliance that operates with a flame, such as a furnace, water heater, or clothes dryer. Also avoid any area with a spark-producing electric motor, or where power tools are operated.

If possible, avoid storage areas with high humidity, because that promotes rust and corrosion.

With the engine and exhaust system cool, cover the tiller to keep out dust. A hot engine and exhaust system can ignite or melt some materials. Do not use sheet plastic as a dust cover. A nonporous cover will trap moisture, promoting rust and corrosion.

### REMOVAL FROM STORAGE

Check your tiller as described in the BEFORE OPERATION chapter (see page 10) of this manual. If the fuel was drained during storage preparation, fill the tank with fresh gasoline. If you keep a container of gasoline for refueling, be sure that it contains only fresh gasoline. Gasoline oxidizes and deteriorates over time, causing hard starting.

If the cylinder was coated with oil during storage preparation, the engine will smoke briefly at startup. This is normal.

## STARTING PROBLEMS

Engine Will Not Start	Possible Cause	Correction
Check control positions.	Engine switch OFF.	Turn engine switch ON.
	Choke lever not in CHOKE (↯) position (cold engine).	Move choke lever to CHOKE (↯) position.
Check fuel.	Out of fuel.	Add fuel.
	Bad fuel, tiller stored without treating or draining gasoline, refueled with bad gasoline.	Drain fuel tank. Refuel with fresh gasoline.
Check spark plug.	Spark plug faulty, fouled, or has incorrect gap.	Clean, gap, or replace the spark plug.
Take tiller to an authorized Honda servicing dealer, or refer to shop manual.	Fuel filter restricted, carburetor malfunction, ignition malfunction, valves stuck, etc.	Replace or repair faulty components as needed.

## ENGINE OPERATING PROBLEMS

Low Power or Engine Speed Won't Increase	Possible Cause	Correction
Check air filter.	Filter dirty or restricted.	Check, clean or replace air filter.
Check fuel filter.	Filter dirty or restricted.	Replace fuel filter.
Check throttle cable.	Out of adjustment, broken, or bent.	Adjust cable, or replace if necessary
Tiller tines (or attachment) won't stop turning when throttle is at SLOW position	Possible Cause	Correction
Check throttle control and cable.	Fault in throttle control or cable; throttle cable out of adjustment or bent.	Check throttle control parts, adjust or replace cable if necessary.
Check clutch.	Clutch springs worn or clutch system faulty.	Replace clutch springs or replace or repair other clutch system parts.

## SPECIFICATIONS

---

### SPECIFICATIONS

#### Engine

Description Code	GCAG
Engine Type	GX31
Displacement	1.89 cu. in. (31 cc)
Bore & Stroke	1.54 x 1.02 (39.17 x 25.91 mm)
Max. Power @ 7,000 rpm	1.5 hp (1.1 kW)
Max. Torque @ 4,500 rpm	1.23 ft-lbs (1.64 N•m)
Ignition System	Transistorized magneto
Spark Plugs	NGK: C5HSB/CR5HSB, ND: U16FS-UM / U16FSR-UB
Starting System	Recoil
Fuel	Unleaded gasoline (86 octane or higher)
Fuel Tank Capacity	23.7 fl. oz. (.7 ℓ)
Fuel Consumption	.13 gal per hour (.5 ℓ per hour)
Lubrication System	Crankcase pressure driven
Oil Capacity	.11 US quart / 3.38 fl oz (0.1 ℓ)
Carburetor Type	Diaphragm type (overflow return) with fuel pump
Air Cleaner	Single element, semi-dry
Idle Speed	3,100 ± 200 rpm
Maximum rpm	9,000 ± 200 rpm
Exhaust	79 dBA

#### Tiller

Model	FG100A
Description Code	FZCV
Width x Length x Height	41.5 x 14 x 39 in (1054 x 355 x 990 mm)
Weight	25 lb (11.3 kg)
Drive Clutch	Centrifugal mechanical
Drive Clutch Engagement Speed	3,800 ± 200 rpm
Tilling Width	10 in (254 mm)
Tilling Depth	8 in (203 mm)
Transmission Drive	Worm gear
Tine Number	4 (4 teeth per tine)



## SERIAL NUMBER LOCATIONS

Record the model and serial number in the boxes below. You will need these numbers when ordering parts and when making technical or warranty inquiries.



Frame Serial Number: **FZCV** .....  
Engine Serial Number: **GCAG** .....

## HONDA PUBLICATIONS

These publications will give you additional information for maintaining and repairing your tiller. You may order them from your Honda tiller dealer.

### Shop Manual

This manual covers complete tiller maintenance and overhaul procedures. It is intended to be used by a skilled technician.

### Parts Listing

This parts listing provides a complete illustrated service parts list.

## AVAILABLE OPTIONS

Below is a list of available options to enhance productivity and comfort when operating your tiller.

### Aerator Attachment

Four, 10-tooth, 8-12 inch aerating tines of heavy gauge, tempered steel that makes hundreds of cuts in the soil, allowing water air and proper nutrients to grass roots.

### Border/Edger Attachment

A 10-tooth, 8-1/2 inch edger tine of heavy gauge tempered steel blade that neatly edges your garden patio, walkways, driveways and flower beds.

### De-Thatcher Attachment

Two de-thatching assemblies containing 3 gangs of 12 spring steel combing fingers cleanly de-thatches your lawn for healthier turf.

### Digging Tines Attachment

Four digging tines which are designed to cut through sod and hard compacted soil or grass covered areas.

# TECHNICAL & CONSUMER INFORMATION

---

## WARRANTY

### Distributors Limited Warranty

PRODUCTS COVERED BY THIS WARRANTY:	LENGTH OF WARRANTY: (from date of original retail purchase)	
	Noncommercial/Nonrental	Commercial/Rental
FG100 Tillers	24 months	3 months

***To Qualify for this Warranty:***

The product must be purchased in the United States, Puerto Rico, or the U.S. Virgin Islands from American Honda or a dealer authorized by American Honda to sell those products. This warranty applies to the first retail purchaser and each subsequent owner during the applicable warranty time period.

***What American Honda will Repair or Replace Under Warranty:***

American Honda will repair or replace, at its option, any part that is proven to be defective in material or workmanship under normal use during the applicable warranty time period. Warranty repairs and replacements will be made without charge for parts or labor. Anything replaced under warranty becomes the property of American Honda Motor Company, Inc. All parts replaced under warranty will be considered as part of the original product and any warranty on those parts will expire coincident with the original product warranty.

***To Obtain Warranty Service:***

You must take the Honda FG100 Tiller and proof of original retail purchase date, at your expense, to any Honda Power Equipment dealer in the United States, Puerto Rico, or the U.S. Virgin Islands who is authorized to service that product, during the dealer's normal business hours. If you are unable to obtain warranty service, or are dissatisfied with the warranty service you receive, take the following steps: First, contact the owner of the dealership involved; normally this should resolve the problem. However, if you should require further assistance, write or call the Power Equipment Customer Relations Department of American Honda Motor Co., Inc. Refer to page 44 for contact information.

Exclusions: THIS WARRANTY DOES NOT EXTEND TO PARTS AFFECTED OR DAMAGED BY ACCIDENT AND/OR COLLISION, NORMAL WEAR, FUEL CONTAMINATION, USE IN AN APPLICATION FOR WHICH THE PRODUCT WAS NOT DESIGNED OR ANY OTHER MISUSE, NEGLIGENCE, INCORPORATION OR USE OF UNSUITABLE ATTACHMENTS OR PARTS, UNAUTHORIZED ALTERATION, OR ANY CAUSES OTHER THAN DEFECTS IN MATERIAL OR WORKMANSHIP OF THE PRODUCT.

TILLER TINES ARE SPECIFICALLY NOT WARRANTED AGAINST DAMAGE, INCLUDING BUT NOT LIMITED TO, ABRASIVE DAMAGE.

***Disclaimer of Consequential Damage and Limitation of Implied Warranties:***

AMERICAN HONDA DISCLAIMS ANY RESPONSIBILITY FOR LOSS OF TIME OR USE OF THE PRODUCT, TRANSPORTATION, COMMERCIAL LOSS, OR ANY OTHER INCIDENTAL OR CONSEQUENTIAL DAMAGE. ANY IMPLIED WARRANTIES ARE LIMITED TO THE DURATION OF THIS WRITTEN LIMITED WARRANTY. Some states do not allow limitations on how long an implied warranty lasts and/or do not allow the exclusion or limitation of incidental or consequential damages, so the above exclusions and limitations may not apply to you.

This warranty gives you specific legal rights, and you may also have other rights which vary from state to state.

## Accessories, Replacement Parts, and Apparel Warranty

PRODUCTS COVERED BY THIS WARRANTY:	LENGTH OF WARRANTY: (from date of original retail purchase)	
	Noncommercial/Nonrental	Commercial/Rental
Accessories	24 months	3 months
Replacement Parts	6 months	3 months
Apparel	6 months	3 months

**To Qualify for this Warranty:**

1. The accessories, replacement parts, or apparel must be purchased in the United States, Puerto Rico, or the U.S. Virgin Islands from American Honda or a dealer authorized by American Honda to sell those products.
2. You must be the first retail purchaser. This warranty is not transferable to subsequent owners.

**What American Honda will Repair or Replace Under Warranty:**

American Honda will repair or replace, at its option, any power equipment accessories, replacement parts, or apparel that are proven to be defective in material or workmanship under normal use during the applicable warranty time period. Anything replaced under warranty becomes the property of American Honda Motor Company, Inc. All parts replaced under warranty will be considered as part of the original product and any warranty on those parts will expire coincident with the original product warranty. Accessories and replacement parts, installed by a dealer who is authorized by American Honda to sell them, will be repaired or replaced under warranty without charge for parts or labor. If installed by anyone else, accessories and replacement parts will be repaired or replaced under warranty without charge for parts, but any labor charges will be the responsibility of the purchaser. Apparel will be repaired or replaced under warranty without any charge.

**To Obtain Warranty Service:**

You must take the Honda Power Equipment accessory, replacement part, apparel or the power equipment on which the accessory or replacement part is installed, and proof of purchase, at your expense, to any Honda Power Equipment dealer in the United States, Puerto Rico, or the U.S. Virgin Islands who is authorized to service that product, during the dealer's normal business hours. If you are unable to obtain warranty service, or are dissatisfied with the warranty service you receive, take the following steps: First, contact the owner of the dealership involved; normally this will resolve the problem. However, if you should require further assistance, write or call the Power Equipment Customer Relations Department of American Honda Motor Co., Inc. Refer to page 44 for contact information.

**Exclusions:**

THIS WARRANTY DOES NOT EXTEND TO ACCESSORIES, PARTS, OR APPAREL AFFECTED OR DAMAGED BY ACCIDENT AND/OR COLLISION, NORMAL WEAR, USE IN AN APPLICATION FOR WHICH THE PRODUCT WAS NOT DESIGNED OR ANY OTHER MISUSE, NEGLIGENCE, INCORPORATION OR USE OF UNSUITABLE ATTACHMENTS OR PARTS, UNAUTHORIZED ALTERATION, IMPROPER INSTALLATION, OR ANY CAUSES OTHER THAN DEFECTS IN MATERIAL OR WORKMANSHIP OF THE PRODUCT.

TILLER TINES, ARE SPECIFICALLY NOT WARRANTED AGAINST DAMAGE, INCLUDING BUT NOT LIMITED TO, ABRASIVE DAMAGE.

**Disclaimer of Consequential Damage and Limitation of Implied Warranties:**

AMERICAN HONDA DISCLAIMS ANY RESPONSIBILITY FOR LOSS OF TIME OR USE OF THE PRODUCT, OR THE POWER EQUIPMENT ON WHICH THE PRODUCT IS INSTALLED, TRANSPORTATION, COMMERCIAL LOSS, OR ANY OTHER INCIDENTAL OR CONSEQUENTIAL DAMAGE. ANY IMPLIED WARRANTIES ARE LIMITED TO THE DURATION OF THIS WRITTEN WARRANTY. Some states do not allow limitations on how long an implied warranty lasts and/or do not allow the exclusion or limitation of incidental or consequential damages, so the above exclusions and limitations may not apply to you.

This warranty gives you specific legal rights, and you may also have other rights which vary from state to state.

# TECHNICAL & CONSUMER INFORMATION

---

## **Emission Control System Warranty**

Your new Honda Power Equipment engine complies with both the U.S. EPA and State of California emission regulations. American Honda provides the same emission warranty coverage for engines sold in all 50 states.

### ***Your Warranty Rights And Obligations:***

#### ***California***

The California Air Resources Board and American Honda Motor Co., Inc. are pleased to explain the emission control system warranty on your Honda Power Equipment engine. In California, new utility and lawn and garden equipment engines must be designed, built and equipped to meet the State's stringent anti-smog standards.

#### ***Other States***

In other areas of the United States your engine must be designed, built, and equipped to meet the U.S. EPA Phase I Emission standard for spark ignited engines at or below 19 kilowatts.

#### ***All States***

American Honda Motor Co., Inc. must warrant the emission control system on your power equipment engine for the period of time listed on the following page provided there has been no abuse, neglect or improper maintenance of your power equipment engine. Where a warrantable condition exists, American Honda Motor Co., Inc. will repair your power equipment engine at no cost to you including diagnosis, parts and labor.

Your emission control system may include such parts as the carburetor or fuel injection system, the ignition system, and catalytic converter. Also included may be hoses, connectors and other emission-related assemblies.

#### ***Manufacturer's Warranty Coverage:***

The 1995 and later power equipment engines are warranted for two years. If any emission-related part on your engine is defective, the part will be repaired or replaced by American Honda Motor Co., Inc.

#### ***Owner's Warranty Responsibility:***

As the power equipment engine owner, you are responsible for the performance of the required maintenance listed in your owner's manual. American Honda Motor Co., Inc. recommends that you retain all receipts covering maintenance on your power equipment engine, but American Honda Motor Co., Inc. cannot deny warranty coverage solely for the lack of receipts or for your failure to ensure the performance of all scheduled maintenance.

As the power equipment engine owner, you should however be aware that American Honda Motor Co., Inc. may deny you warranty coverage if your power equipment engine or a part has failed due to abuse, neglect, improper maintenance, or unapproved modifications.

You are responsible for presenting your power equipment engine to a Honda Power Equipment dealer as soon as a problem exists. The warranty repairs should be completed in a reasonable amount of time, not to exceed 30 days.

If you have any questions regarding your warranty rights and responsibilities, you should write or call the Honda Power Equipment Customer Relations Department. Refer to page 44 for contact information.

#### ***Warranty Coverage:***

Honda Power Equipment engines manufactured after January 1, 1995 and sold in the State of California, and U.S. EPA certified engines manufactured on or after September 1, 1996 and sold in all of the United States, are covered by this warranty for a period of two years from the date of delivery to the original retail purchaser. This warranty is transferable to each subsequent purchaser for the duration of the warranty period.

Warranty repairs will be made without charge for diagnosis, parts or labor. All defective parts replaced under this warranty become the property of American Honda Motor Co., Inc. A list of warranted parts is on the reverse side of this warranty statement. Normal maintenance items, such as spark plugs and filters, that are on the warranted parts list are warranted up to their required replacement interval only.

American Honda Motor Co., Inc. is also liable for damages to other engine components caused by a failure of any warranted part during the warranty period.

Only Honda approved replacement parts may be used in the performance of any warranty repairs and must be provided without charge to the owner. The use of replacement parts not equivalent to the original parts may impair the effectiveness of your engine emission control system. If such a replacement part is used in the repair or maintenance of your engine, and an authorized Honda dealer determines it is defective or causes a failure of a warranted part, your claim for repair of your engine may be denied. If the part in question is not related to the reason your engine requires repair, your claim will not be denied.

**To Obtain Warranty Service:**

You must take your Honda Power Equipment engine or the product on which it is installed, along with your warranty registration card or other proof of original purchase date, at your expense, to any Honda Power Equipment dealer who is authorized by American Honda Motor Co., Inc. to sell and service that Honda product during his normal business hours. Claims for repair or adjustment found to be caused solely by defects in material or workmanship will not be denied because the engine was not properly maintained and used.

If you are unable to obtain warranty service, or are dissatisfied with the warranty service you received, contact the owner of the dealership involved. Normally this should resolve your problem. However, if you require further assistance, write or call the Power Equipment Customer Relations Department of American Honda Motor Co., Inc. Refer to page 44 for contact information.

**Exclusions:**

FAILURES OTHER THAN THOSE RESULTING FROM DEFECTS IN MATERIAL OR WORKMANSHIP ARE NOT COVERED BY THIS WARRANTY. THIS WARRANTY DOES NOT EXTEND TO EMISSION CONTROL SYSTEMS OR PARTS WHICH ARE AFFECTED OR DAMAGED BY OWNER ABUSE, NEGLIGENCE, IMPROPER MAINTENANCE, MISUSE, MISFUELING, IMPROPER STORAGE, ACCIDENT AND/OR COLLISION, THE INCORPORATION OF, OR ANY USE OF, ANY ADD-ON OR MODIFIED PARTS, UNSUITABLE ATTACHMENTS, OR THE UNAUTHORIZED ALTERATION OF ANY PART.

THIS WARRANTY DOES NOT COVER REPLACEMENT OF EXPENDABLE MAINTENANCE ITEMS MADE IN CONNECTION WITH REQUIRED MAINTENANCE SERVICES AFTER THE ITEM'S FIRST SCHEDULED REPLACEMENT AS LISTED IN THE MAINTENANCE SECTION OF THE PRODUCT OWNER'S MANUAL, SUCH AS: SPARK PLUGS AND FILTERS.

**Disclaimer of Consequential Damage and Limitation of Implied Warranties:**

AMERICAN HONDA MOTOR CO., INC. DISCLAIMS ANY RESPONSIBILITY FOR INCIDENTAL OR CONSEQUENTIAL DAMAGES SUCH AS LOSS OF TIME OR THE USE OF THE POWER EQUIPMENT, OR ANY COMMERCIAL LOSS DUE TO THE FAILURE OF THE EQUIPMENT; AND ANY IMPLIED WARRANTIES ARE LIMITED TO THE DURATION OF THIS WRITTEN WARRANTY. THIS WARRANTY IS APPLICABLE ONLY WHERE THE CALIFORNIA OR U.S. EPA EMISSION CONTROL SYSTEM WARRANTY REGULATION IS IN EFFECT.

**Emission Control System Warranty Parts**

<b>SYSTEMS COVERED BY THIS WARRANTY</b>	<b>PARTS DESCRIPTION</b>
Fuel Metering	Carburetor assembly Fuel injection pump Fuel injection nozzle Fuel regulator
Exhaust System	Catalyst
Air Induction	Air filter housing Air filter element* Crankcase breather tube
Ignition	Flywheel magneto Ignition pulse generator Ignition control module Ignition coil assembly Spark plug cap Spark plug*
Miscellaneous Parts	Tubing, fittings, seals, gaskets and clamps associated with these listed systems.

\* Covered up to the first required replacement only. See the Maintenance Schedule on page 18.

### Manual en Español

Una versión de este manual en Español esta disponible. Favor de ponerse en contacto con el departamento de relaciones al cliente a la dirección o teléfono listado abajo.

## WARRANTY SERVICE INFORMATION

Honda Power Equipment dealership personnel are trained professionals. They should be able to answer any question you may have. If you encounter a problem that your dealer does not solve to your satisfaction, please discuss it with the dealership's management. The Service Manager or General Manager can help. Almost all problems are solved in this way.

If you are dissatisfied with the decision made by the dealership's management, contact the Honda Power Equipment Customer Relations Office.

You can write to:

American Honda Motor Co., Inc.  
Power Equipment Division  
Customer Relations Office  
4475 River Green Parkway  
Duluth, GA 30096-2565

Or telephone: (770) 497-6400 weekdays, 8:30 a.m. - 5:00 p.m. EST

When you call or write, please provide us the following information:

- Model and serial numbers (tiller and power unit)
- Name of the dealer who sold you the tiller
- Name and address of the dealer who services your tiller
- Date of purchase
- Your name, address, and telephone number
- A detailed description of the problem

### OXYGENATED FUELS

Some conventional gasolines are being blended with alcohol or an ether compound. These gasolines are collectively referred to as oxygenated fuels. To meet clean air standards, some areas of the USA and Canada use oxygenated fuels to help reduce emissions. If you use an oxygenated fuel, be sure it is unleaded and meets the minimum octane rating requirement. Before using an oxygenated fuel, try to confirm the fuel's contents. Some states/provinces require this information to be posted on the pump.

The following are the EPA approved percentages of oxygenates:

**ETHANOL** ----- (ethyl or grain alcohol) 10% by volume

You may use gasoline containing up to 10% ethanol by volume. Gasoline containing ethanol may be marketed under the name "Gasohol".

**MTBE**----- (Methyl Tertiary Butyl Ether) 15% by volume

You may use gasoline containing up to 15% MTBE by volume.

**METHANOL** ----- (methyl or wood alcohol) 5% by volume

You may use gasoline containing up to 5% methanol by volume, as long as it also contains cosolvents and corrosion inhibitors to protect the fuel system. Gasoline containing more than 5% methanol by volume may cause starting and/or performance problems. It may also damage metal, rubber, and plastic parts of your fuel system.

If you notice any undesirable operating symptoms, try another service station, or switch to another brand of gasoline. Fuel system damage or performance problems resulting from the use of an oxygenated fuel containing more than the percentages of oxygenates mentioned above are not covered under warranty.

### Carburetor Modifications for High Altitude Operation

At high altitude, the standard carburetor air-fuel mixture will be too rich. Performance will decrease, and fuel consumption will increase. A very rich mixture will also foul the spark plug and cause hard starting.

High altitude performance can be improved by specific modifications to the carburetor. If you always operate your tiller at altitudes above 5,000 feet (1,500 meters), have your servicing dealer perform this carburetor modification.

Even with carburetor modification, engine horsepower will decrease about 3.5% for each 1,000-foot (300-meter) increase in altitude. The effect of altitude on horsepower will be greater than this if no carburetor modification is made.

#### NOTICE

When the carburetor has been modified for high altitude operation, the air-fuel mixture will be too lean for low altitude use.

Operation at altitudes below 5,000 feet (1,500 meters) with a modified carburetor may cause the engine to overheat and result in serious engine damage. For use at low altitudes, have your servicing dealer return the carburetor to original factory specifications.

# TECHNICAL & CONSUMER INFORMATION

---

## EMISSION CONTROL SYSTEM INFORMATION

### Source of Emissions

The combustion process produces carbon monoxide, oxides of nitrogen, and hydrocarbons. Control of hydrocarbons and oxides of nitrogen is very important because, under certain conditions, they react to form photochemical smog when subjected to sunlight. Carbon monoxide does not react in the same way, but it is toxic.

Honda utilizes lean carburetor settings and other systems to reduce the emissions of carbon monoxide, oxides of nitrogen, and hydrocarbons.

### The U.S and California Clean Air Acts

EPA and California regulations require all manufacturers to furnish written instructions describing the operation and maintenance of emission control systems.

The following instructions and procedures must be followed in order to keep the emissions from your Honda engine within the emission standards.

### Tampering and Altering

Tampering with or altering the emission control system may increase emissions beyond the legal limit. Among those acts that constitute tampering are:

- Removal or alteration of any part of the intake, fuel, or exhaust systems.
- Altering or defeating the governor linkage or speed-adjusting mechanism to cause the engine to operate outside its design parameters.

### Problems that may Affect Emissions

If you are aware of any of the following symptoms, have your engine inspected and repaired by your servicing dealer.

- Hard starting or stalling after starting.
- Rough idle.
- Misfiring or backfiring under load.
- Afterburning (backfiring).
- Black exhaust smoke or high fuel consumption.

### Replacement Parts

The emission control systems on your new Honda engine were designed, built, and certified to conform with EPA and California emission regulations. We recommend the use of genuine Honda parts whenever you have maintenance done. These original-design replacement parts are manufactured to the same standards as the original parts, so you can be confident of their performance. The use of replacement parts that are not of the original design and quality may impair the effectiveness of your emission control system.

A manufacturer of an aftermarket part assumes the responsibility that the part will not adversely affect emission performance. The manufacturer or rebuilder of the part must certify that use of the part will not result in a failure of the engine to comply with emission regulations.

### Maintenance

Follow the maintenance schedule on page 18. Remember that this schedule is based on the assumption that your machine will be used for its designed purpose. Sustained high-load or high-temperature operation, or use in unusually wet or dusty conditions, will require more frequent service.



## THE AIR INDEX

An Air Index Information hang tag/label was applied to this engine in accordance with the requirements of the California Air Resources Board.

The bar graph is intended to provide you, our customer, the ability to compare the emissions performance of available engines. The lower the Air Index, the less pollution.

The durability description is intended to provide you with information relating to the engine's emission durability period. The descriptive term indicates the useful-life period for the engine's emission control system. See your *Emission Control System Warranty* for additional information (see page 42).

Descriptive Term	Applicable to Emissions Durability Period
Moderate	50 hours (0 – 65 cc) 125 hours (greater than 65 cc)
Intermediate	125 hours (0 – 65 cc) 250 hours (greater than 65 cc)
Extended	300 hours (0 – 65 cc) 500 hours (greater than 65 cc)

The Air Index Information hang tag/label must remain on the mini-tiller until it is sold. Remove the hang tag/label before operating the tiller.

## REPLACEMENT PARTS

Replacement parts may be purchased from authorized servicing Honda tiller dealer.

Description		Part Number	Notes
Air filter		17211-ZM3-800	
Spark plug	NGK	98056-55777	
	DENSO	98056-55757	
Engine oil		08209-10W30	
Tine "A"		72466-V06-003	
Tine "B"		72465-V06-003	
Tine "C"		72461-V06-003	
Tine "D"		72462-V06-003	
Silicone spray		08209-0001	Lubricates throttle cable core
Fuel stabilizer		08732-0001	For long term storage
Matte black touch-up paint (aerosol can)		08707-NH105	For handlebar only

# INDEX

---

## A

Assembly .....	28
Air Filter.....	20
Cleaning .....	21
Inspection .....	20

## B

Before Operation.....	10
-----------------------	----

## C

Carburetor Adjustment.....	24
Carrying Handle.....	9
Choke Lever.....	8
Clothing Recommendations.....	10
Component Identification .....	7
Contents .....	3
Cooling Fin Inspection .....	24

## D

Damage Prevention Message Definition.....	1
Description Of Controls.....	8
Drag Bar.....	9

## E

Emission Control System.....	42
Engine:	
Fuel Recommendations .....	25
Oil Change .....	19
Oil Level .....	19
Oil Recommendations .....	20
Operating Problems .....	37
Refueling .....	25
Serial Number .....	39
Switch.....	8 & 13

## F

Frame Serial Number.....	39
Fuel:	
Additive to Extend Storage Life.....	35
Gasoline Recommendations .....	25
Draining.....	26
Refueling .....	25
Fuel Filter.....	26

## G

Gasoline Recommendations.....	25
-------------------------------	----

## H

Handlebars:	
Adjustment .....	12
Folding for Transportation .....	34

## I

Idle Speed Adjustment.....	24
Importance Of Proper Assembly.....	28
Important Safety Precautions.....	28
Inspection Before Tilling:	
Tilling Area .....	11
Tiller.....	11

## L

Loose Parts.....	29
------------------	----

## M

Maintenance:	
Air Filter .....	20
Cooling Fins .....	24
Engine Oil.....	19
Fuel System .....	25
Idle Speed .....	24
Importance .....	17
Schedule .....	18
Spark Arrester .....	23
Spark Plug.....	22
Throttle Cable.....	24
Transmission .....	27
Moving the Tiller.....	12

## O

Oil, Engine:	
Change.....	19
Level Check.....	19
Recommendations .....	20
Operating the Tiller .....	14
Options .....	39
Oxygenated Fuels.....	45

## P

Parts, Replacement .....	47
Publications.....	39
Priming Bulb.....	8 & 13

## R

Recoil Starter .....	9 & 13
Replacement Parts .....	47

## S

Safety:.....	4
Attachments and Modifications .....	5
Important Message To Employers .....	5
Important Message To Parents .....	5
Important Safety Information .....	4
Safety Label Locations .....	6
Safety Precautions.....	12
Serial Numbers .....	39
Spark Arrester Service.....	23
Spark Plug Service .....	22
Specifications.....	38
Starting Problems .....	37
Starting/Stopping The Engine .....	13
Storage .....	34

## T

Taking Care Of Unexpected Problems .....	37
Throttle Lever:	
Assembly.....	32
Cable Inspection.....	24
Operation.....	8 & 14
Transmission.....	27
Transporting .....	34
Transport Wheels.....	9 & 12

## U

Unpacking.....	29
----------------	----

## W

Warranty:	
Accessories, Replacement Parts, and Apparel .....	41
Distributor's Limited.....	40
Emission Control System .....	42
Service Information .....	44

## QUICK REFERENCE

### Maintenance

Fuel	Type	Unleaded gasoline with a pump octane rating of 86 or higher	See page 25.
	Capacity	0.75 US qt (.7ℓ)	
Engine Oil	Type	SAE 10W-30, API . SH or SJ	See page 20.
	Capacity	0.11 US qt(.10ℓ)	
Transmission Lubricant (SD)	Type	Grease (NLGI #2)	See page 27.
Spark Plug  (Resistor plugs reduce the interference with radio and television reception.)	Type	<b>Regular:</b> NGK C5HSB DENSO U16FS-UB <b>Resistor:</b> NGK - CR5HSB DENSO - U16FSR-UB	See page 22.
Maximum Engine Speed		9,000 ± 200 rpm	See shop manual.
Throttle Cable		Adjust for proper free play	See page 24.

### Tuneup

Spark Plug Gap	0.024 ~ 0.028 in (0.6 ~ 0.7 mm)	See page 22.
Idle Speed	3,100 ± 200 rpm	See page 24.
Valve Clearance (cold)	Intake: 0.12 ± 0.02 mm Exhaust: 0.15 ± 0.02 mm	See shop manual.
Other Specifications	No other adjustments needed.	

# HONDA

31V06600  
00X31-V06-6000



Printed on  
Recycled Paper

POM52753  
ECP 80009712  
Printed in U.S.A.