

HONDA

Power

Equipment

Owner's Manual

SNOWBLOWER

HS55

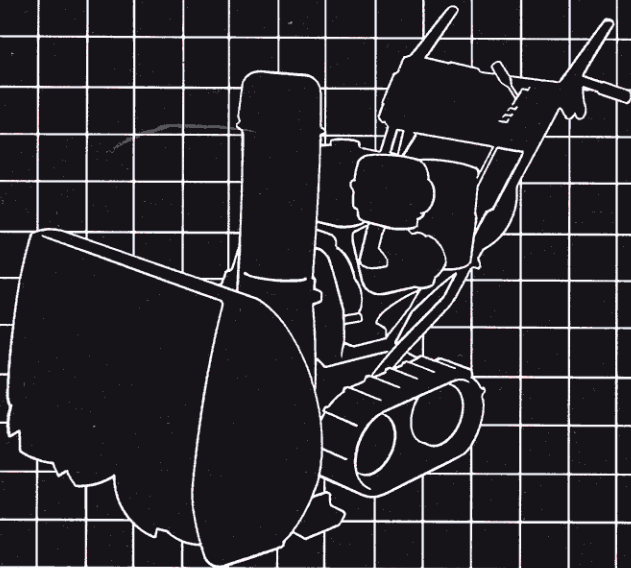

Thank you for purchasing a Honda snowblower.

This manual covers the operation and maintenance of the HS55 snowblower.

All information in this publication is based on the latest product information available at the time of approval for printing.

Honda Motor Co., Ltd. reserves the right to make changes at any time without notice and without incurring any obligation.

No part of this publication may be reproduced without written permission.

This manual should be considered a permanent part of the snowblower and should remain with the snowblower if it is resold.

Pay special attention to statements preceded by the following words:

⚠ DANGER: Indicates severe personal injury or death will result if instructions are not followed.

⚠ WARNING Indicates a strong possibility of severe personal injury or death if instructions are not followed.

CAUTION: Indicates a possibility of personal injury or equipment damage if instructions are not followed.

NOTE: Gives helpful information.

If a problem should arise, or if you have any questions about your snowblower, consult an authorized Honda snowblower dealer.

⚠ WARNING Operating this equipment requires special effort to ensure the safety of the operator and the safety of others. Read and understand this Owner's Manual before operating this equipment; failure to do so could result in personal injury or equipment damage.

HONDA MOTOR CO., LTD. 1987, ALL RIGHTS RESERVED

CONTENTS

1. POWER EQUIPMENT SAFETY	3
2. WARNING LABEL LOCATION	5
3. COMPONENT IDENTIFICATION AND FUNCTION	6
ENGINE SWITCH AND AC STARTER BUTTON	8
FUEL VALVE	8
CHOKE LEVER	9
STARTER GRIP	9
THROTTLE LEVER (ENGINE SPEED)	10
SHIFT LEVER	10
AUGER CLUTCH LEVER AND DRIVE CLUTCH LEVER	11
CHUTE CRANK	12
CHUTE GUIDE	12
SKID PLATE	13
HEIGHT ADJUSTMENT PEDAL (TRACK MODEL ONLY)	14
4. PRE-OPERATION CHECK	15
FUEL LEVEL	15
ENGINE OIL LEVEL	17
5. STARTING THE ENGINE	18
6. SNOWBLOWER OPERATION	21
HIGH ALTITUDE OPERATION	21
7. STOPPING THE ENGINE	23
8. MAINTENANCE	24
MAINTENANCE SCHEDULE	24
TOOL KIT	25
ENGINE OIL CHANGE	26
SPARK PLUG SERVICE	27
TRACK-ADJUSTMENT (TRACK MODEL ONLY)	28
9. STORAGE	29
10. TROUBLESHOOTING	32
11. SPECIFICATIONS	33
12. WARRANTY SERVICE	34

1. POWER EQUIPMENT SAFETY

WARNING

To ensure safe operation —

- Before operating the snowblower, inspect the area in which you are going to clear snow. Remove debris and other obstacles the snowblower might strike or throw, as that may cause injury or damage to the snowblower.
- Inspect the snowblower before operating it. Repair any damage and correct any malfunction before operation. If you hit an obstacle while operating the snowblower, stop the engine immediately, and check for damage. Damaged equipment may increase the possibility of injury during operation.
- Do not use the snowblower when visibility is poor. Under conditions of poor visibility, there is a greater risk of striking an obstacle or causing injury.
- Never use the snowblower to clear snow from a gravel road or driveway, as rocks may be picked up and thrown. They may cause injury to bystanders.
- Adjust the snow discharge chute to avoid hitting the operator, bystanders, windows, and other objects with thrown snow. Stay clear of the snow discharge chute while the engine is running.
- Children and pets must be kept away from the area of operation to avoid injury from flying debris and contact with the snowblower.
- To avoid overturning, be careful when changing the direction of the snowblower while operating it on a slope. Do not use the snowblower to remove snow from roofs. The snowblower may overturn on steep slopes if left unattended, causing injury to the operator or bystanders.

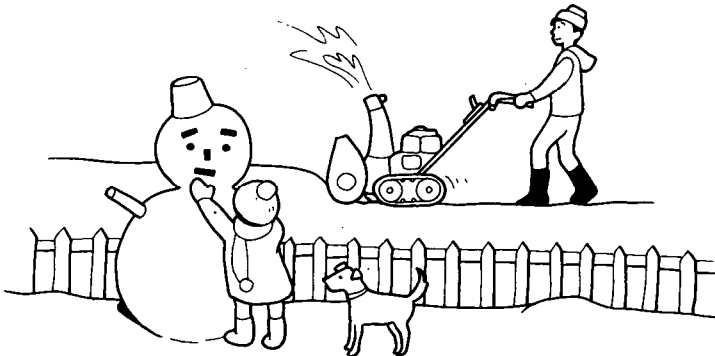

WARNING

- Know how to stop the snowblower quickly, and understand the operation of all controls.
- Never permit anyone to operate the snowblower without proper instruction. If people or pets suddenly appear in front of the snowblower while it is in operation, immediately release the auger and drive clutch levers to stop the snowblower and avoid possible injury from rotating auger blades.
- If the snow discharge chute becomes clogged, stop the engine and use a wooden stick to unclog it. Never put your hand into the snow discharge chute while the engine is running; serious personal injury could result.
- Gasoline is extremely flammable and is explosive under certain conditions. Do not smoke or allow flames or sparks where the snowblower is refueled or where gasoline is stored. Refuel in a well-ventilated area with the engine stopped. Do not overfill the fuel tank, and make sure the filler cap is closed securely after refueling.
- Never run the engine in an enclosed or confined area. Exhaust contains poisonous carbon monoxide gas; exposure can cause loss of consciousness and may lead to death.
- The muffler becomes very hot during operation and remains hot for a while after stopping the engine. Be careful not to touch the muffler while it is hot. Let the engine cool before storing the snowblower indoors.
- Always make a pre-operation inspection (page 15) before you start the engine. You may prevent an accident or equipment damage.

NOTE: While operating the snowblower, hold the handle firmly, and walk, don't run. Wear suitable winter boots that resist slipping.

2. WARNING LABEL LOCATION

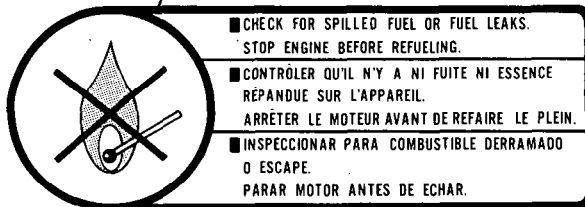
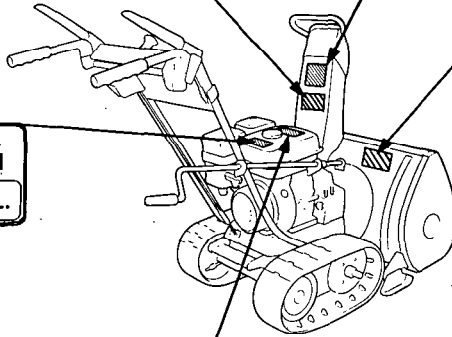

3. COMPONENT IDENTIFICATION AND FUNCTION

WHEEL TYPE

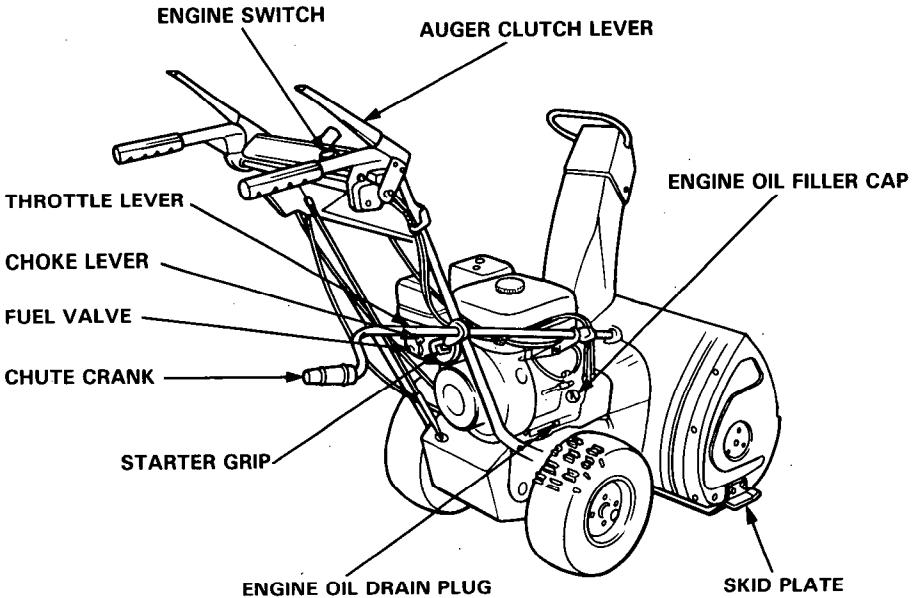
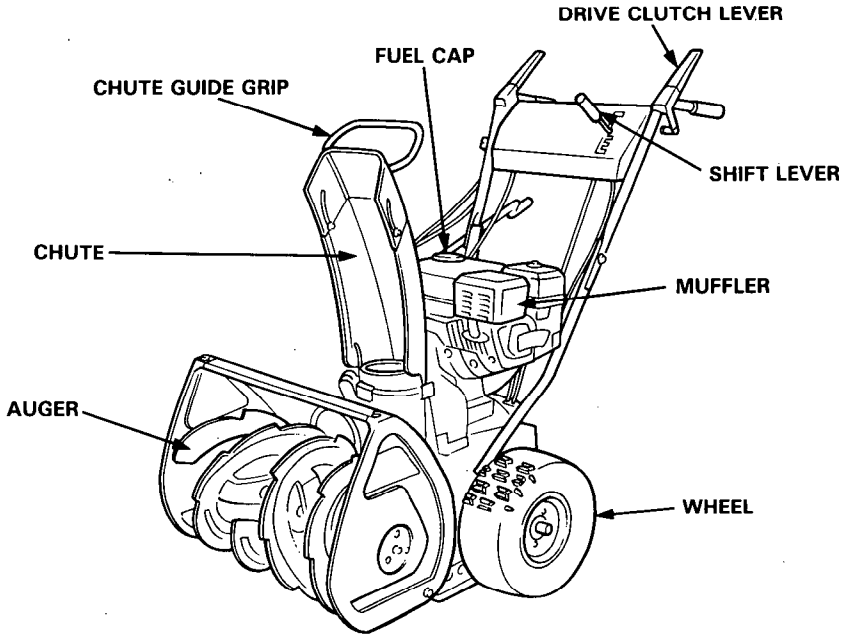

TRACK TYPE

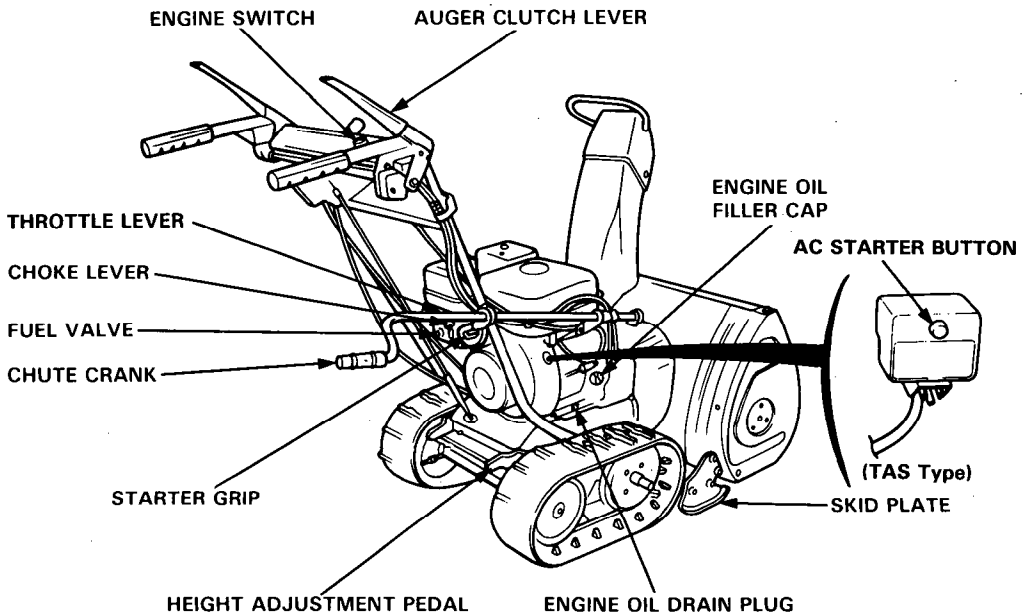
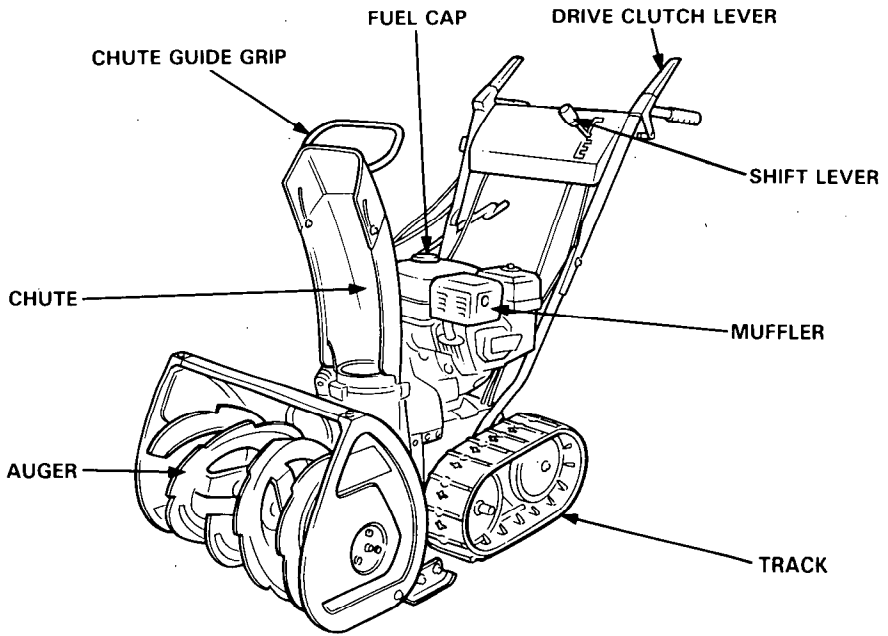

ENGINE SWITCH

Use the engine switch to turn the ignition system ON for starting, and to STOP the engine.

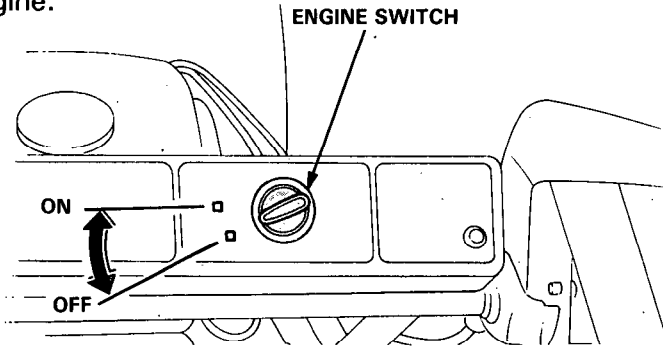

A.C. STARTER BUTTON

Push the A.C. starter button to operate the electric starter. (TAS Type)

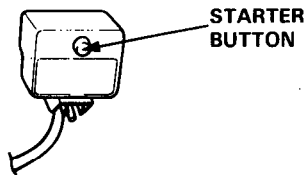

FUEL VALVE

The fuel valve opens and closes the fuel line leading from the fuel tank to the carburetor. Make sure that the valve is positioned exactly at either the ON or OFF position.

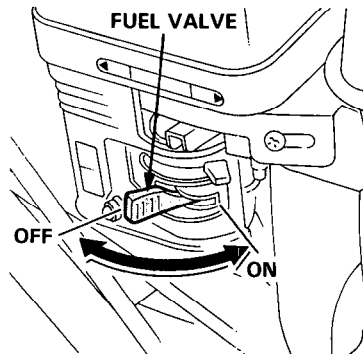

NOTE: Before transporting the snowblower, be sure to turn the fuel valve to OFF to prevent possible fuel leaks.

CHOKE LEVER/ROD

Close the choke when the engine is cold or difficult to start.

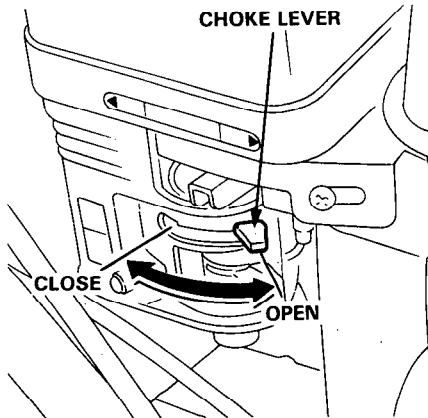

STARTER GRIP

Pull this grip to start the engine.

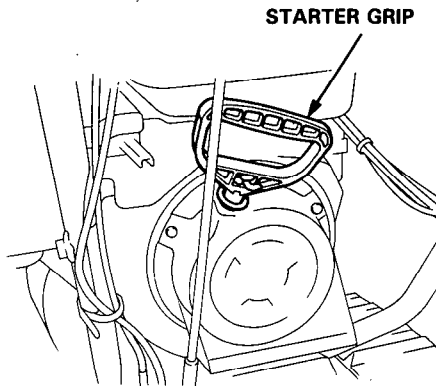

THROTTLE LEVER (ENGINE SPEED)

Use the throttle lever to select engine speed. In normal operation, use the FAST position.

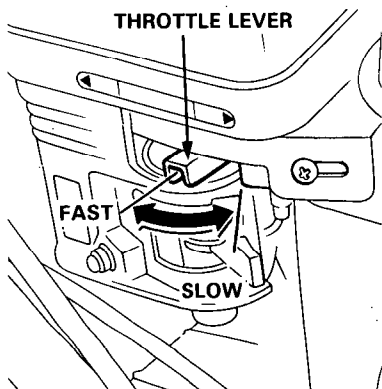

SHIFT LEVER

Use the shift lever to select drive speed or direction.

- 1: LOW SPEED
- 2: MEDIUM SPEED
- 3: HIGH SPEED
- N: NEUTRAL
- R: REVERSE

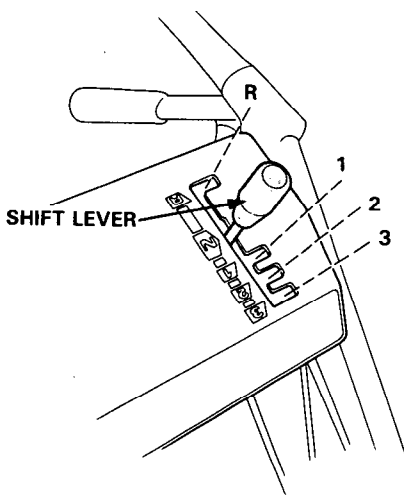

AUGER CLUTCH LEVER AND DRIVE CLUTCH LEVER

Use these controls to engage the snow blowing mechanism and/or the drive mechanism.

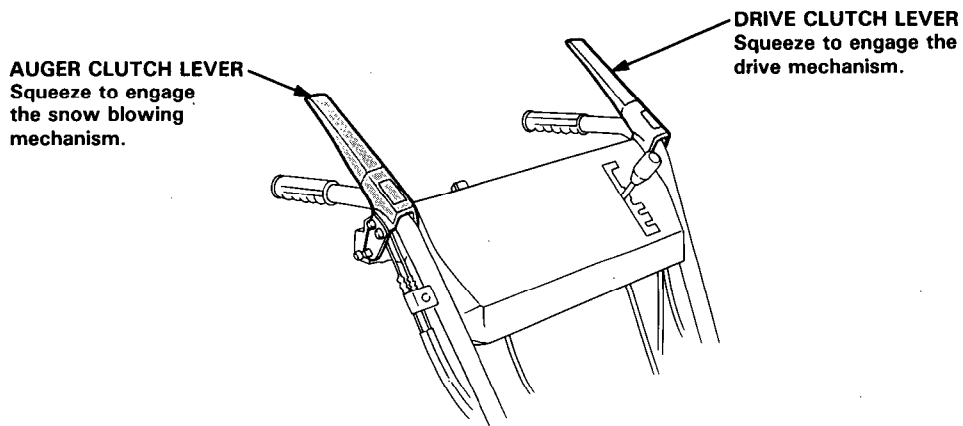

NOTE: When both levers are squeezed, the drive clutch lever locks the auger clutch lever down. Releasing the drive clutch lever then unlocks and releases the auger clutch lever.

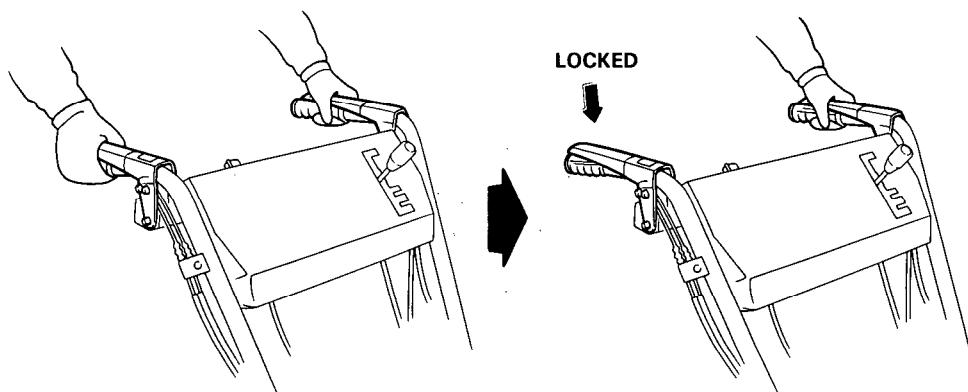

Both levers squeezed

The auger clutch lever remains locked down so long as one hand continues to squeeze the drive clutch lever.

CHUTE CRANK

Use the chute crank to turn the snow discharge chute right or left.

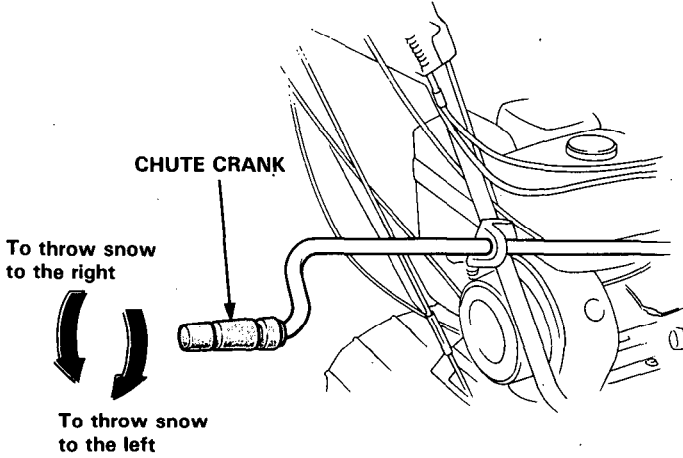

CHUTE GUIDE

The chute guide controls the snow discharge angle.

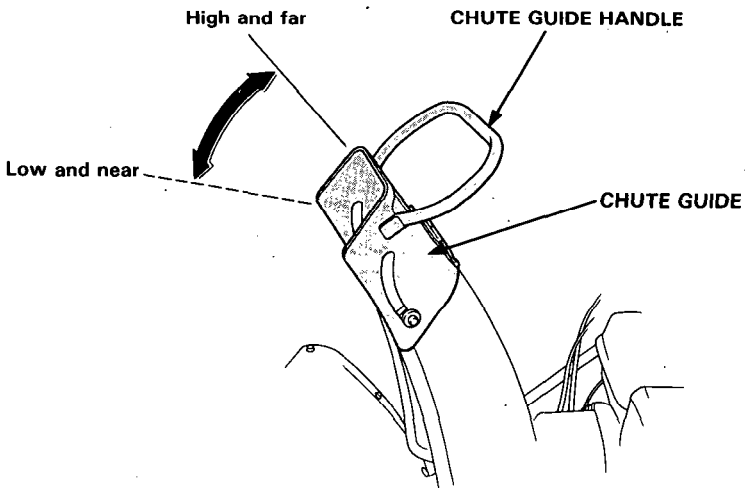

SKID PLATE

Adjust the skid plates for the auger housing ground clearance best suited to your snow removal conditions.

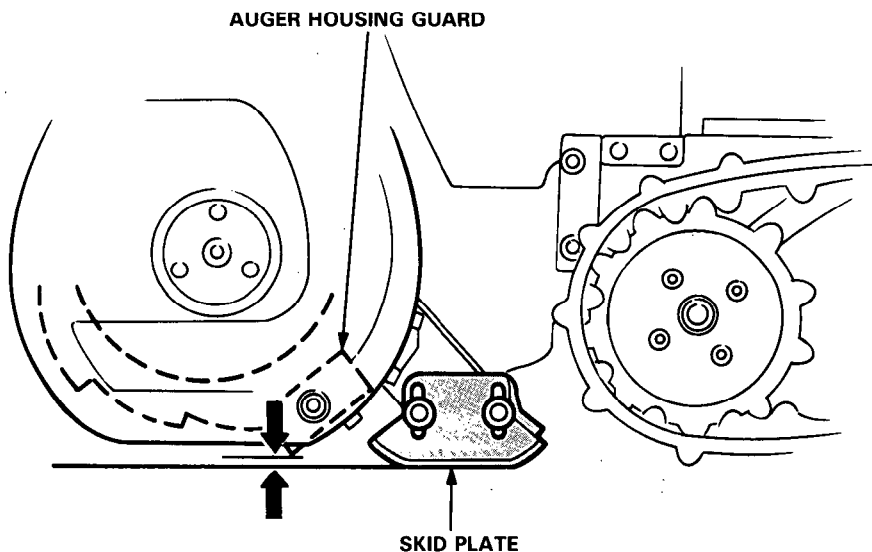

SNOW REMOVAL CONDITIONS	RECOMMENDED AUGER HOUSING GROUND CLEARANCE
For general use	6– 8 mm (0.24–0.31 in)
For use on uneven surfaces	10–30 mm (0.39–1.18 in)
For use on flat surfaces	0– 5 mm (0–0.20 in)

NOTE: Track model only — The position of the height adjustment pedal (p. 14) also affects auger housing ground clearance. Set the height adjustment pedal in the middle position before adjusting the skid plates.

HEIGHT ADJUSTMENT PEDAL (Track model only)

Use the pedal for adjusting the height and angle of the machine in relation to the tracks.

1. Hold the handles and step on the pedal.
2. Raise or lower the machine to the desired position and release the pedal.

LOW : Hard snow or fine finish

MIDDLE: Normal use

HIGH : Deep snow or for transporting the snowblower.

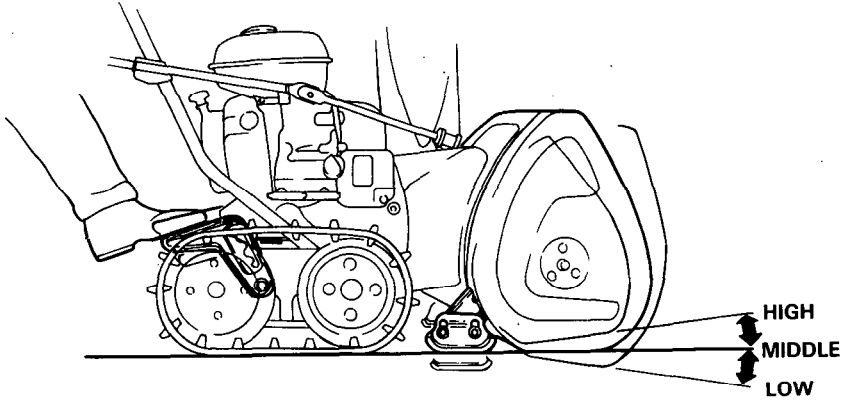

4. PRE-OPERATION CHECK

FUEL LEVEL

Unscrew the fuel cap. Check the fuel level.

Your engine is designed to use any gasoline that has a pump octane number $(\frac{R + M}{2})$ of 86 or higher, or that has a research octane number of 91 or higher. Gasoline pumps at service station normally display the pump octane number.

We recommend that you use unleaded fuel because it produces fewer engine and spark plug deposits and extends the life of exhaust system components.

Never use stale or contaminated gasoline or an oil/gasoline mixture. Avoid getting dirt, dust or water in the fuel tank. Use of a lower octane gasoline can cause persistent "pinging" or heavy "spark knock" (a metallic rapping noise) which, if severe, can lead to engine damage.

CAUTION: If "spark knock" or "pinging" occurs at a steady engine speed under normal load, change brands of gasoline. If spark knock or pinging persists, consult your authorized Honda dealer. Failure to do so is considered misuse, and damage caused by misuse is not covered by Honda's Limited Warranty.

Occasionally you may experience light spark knock while operating under heavy loads. This is no cause for concern, it simply means your engine is operating efficiently.

After refueling, be sure to tighten the fuel tank cap firmly.

CAUTION: Be careful that snow does not enter the tank while refueling. Water in the fuel system can cause the engine to stall and to be difficult to start.

FUEL TANK CAPACITY: 3.5 l (0.92 US gal, 0.77 Imp gal)

FUEL FILLER OPENING

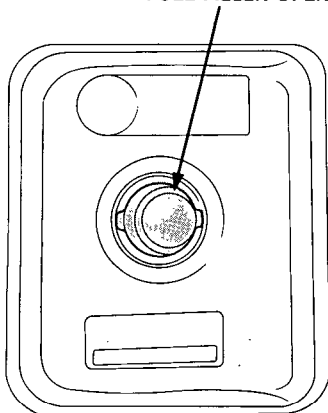

WARNING

- Gasoline is extremely flammable and is explosive under certain conditions.
- Refuel in a well-ventilated area with the engine stopped. Do not smoke or allow flames or sparks in the area where the engine is refueled or where gasoline is stored.
- Do not overfill the fuel tank (there should be no fuel in the filler neck). After refueling, make sure the tank cap is closed properly and securely.
- Be careful not to spill fuel when refueling. Spilled fuel or fuel vapor may ignite. If any fuel is spilled, make sure the area is dry before starting the engine.
- Avoid repeated or prolonged contact with skin or breathing of vapor. **KEEP OUT OF REACH OF CHILDREN.**

GASOLINES CONTAINING ALCOHOL

If you decide to use a gasoline containing alcohol (gasohol), be sure it's octane rating is at least as high as that recommended by Honda. There are two types of "gasohol": one containing ethanol, and the other containing methanol. Do not use gasohol that contains more than 10% ethanol. Do not use gasoline containing methanol (methyl or wood alcohol) that does not also contain cosolvents and corrosion inhibitors for methanol. Never use gasoline containing more than 5% methanol, even if it has cosolvents and corrosion inhibitors.

NOTE:

- Fuel system damage or engine performance problems resulting from the use of fuels that contain alcohol is not covered under the warranty. Honda cannot endorse the use of fuels containing methanol since evidence of their suitability is as yet incomplete.
- Before buying fuel from an unfamiliar station, try to find out if the fuel contains alcohol, if it does, confirm the type and percentage of alcohol used. If you notice any undesirable operating symptoms while using a gasoline that contains alcohol, or one that you think contains alcohol, switch to a gasoline that you know does not contain alcohol.

ENGINE OIL LEVEL

Inspection:

With the snowblower on a level surface, remove the oil filler cap and wipe the dipstick clean. Insert the dipstick into the filler neck, but do not screw it in. Remove the dipstick and check the oil level.

If the level is low, fill to the top of the oil filler neck with the recommended oil.

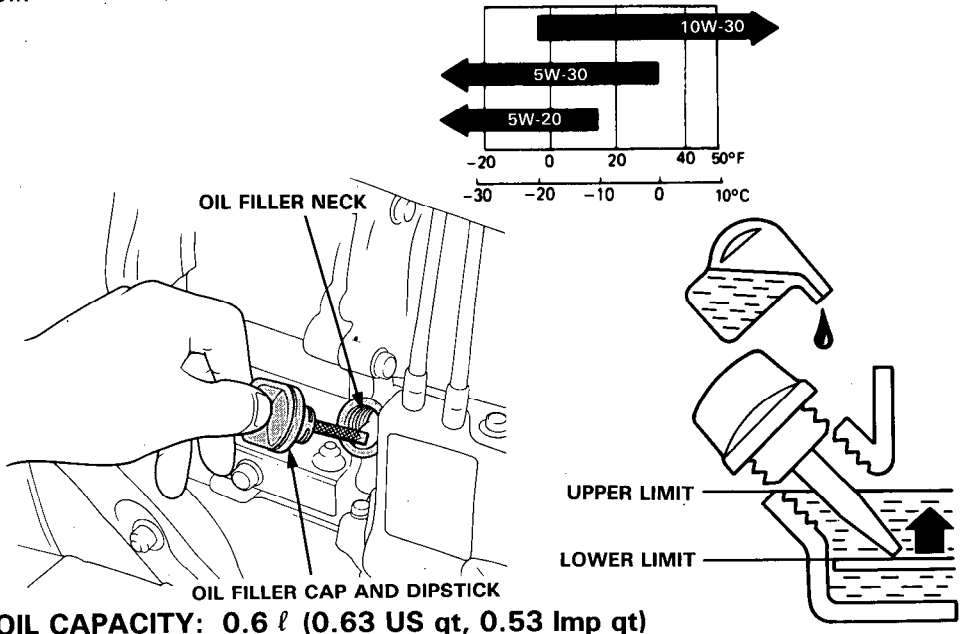

OIL CAPACITY: 0.6 l (0.63 US qt, 0.53 Imp qt)

RECOMMENDED OIL:

Use high detergent, premium quality motor oil certified to meet or exceed U.S. automobile manufacturers' requirements for service classification SE or SF (Motor oils classified SE or SF will show this designation on the container.) Select the appropriate oil viscosity for the average temperature in your area, as shown in the chart above. SAE 5W-30 is recommended for general, all-temperature use.

CAUTION:

- Engine oil is a major factor affecting engine performance and service life. Non-detergent oils or 2-stroke engine oils are not recommended.
- Running the engine with insufficient oil can cause serious engine damage.

5. STARTING THE ENGINE

WARNING Never run the engine in an enclosed or confined area. Exhaust contains poisonous carbon monoxide gas; exposure can cause loss of consciousness and may lead to death.

1. Turn the engine switch to the ON position.

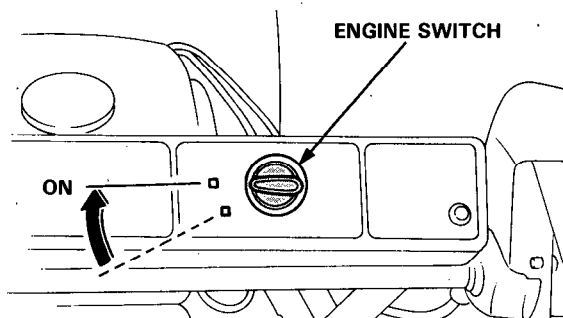

- Connect the female end of your power cord to the switch box and the male end to a properly grounded 120 Volt A/C outlet. (TAS Type)

CAUTION
USE ONLY WITH GROUNDED
OUTLET AND 3-WIRE CORD.
120 VOLT A.C. ONLY.
DO NOT CRANK OVER
1 MINUTE WITHOUT
COOLING 15 MINUTES.
DO NOT USE IN RAIN

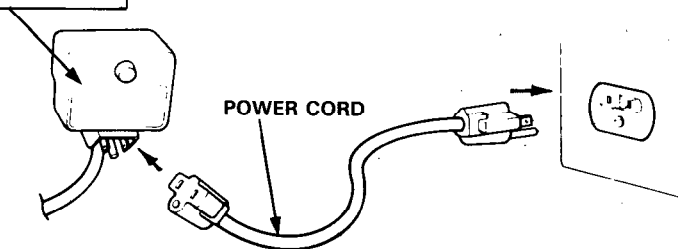

WARNING

- To minimize the possibility of potentially dangerous electrical shocks, always use a 3-conductor power cord with a power rating of no less than 15 amps.
Also, be sure that the outlet you are using is properly grounded.
- Do not connect and disconnect the power cord with wet hands.
- Be sure to hold the plug when disconnecting the power cord from the electrical outlet or switch box.

2. Turn the fuel valve to the ON position.

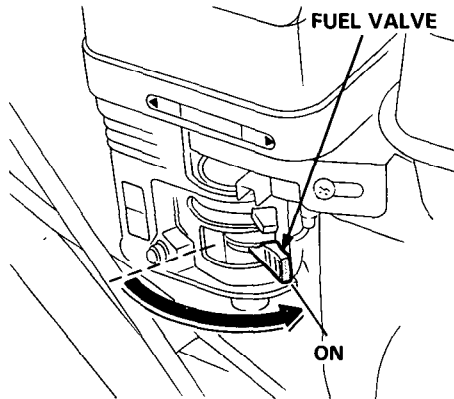

3. In cold weather and when the engine is cold, move the choke to the CLOSE position.

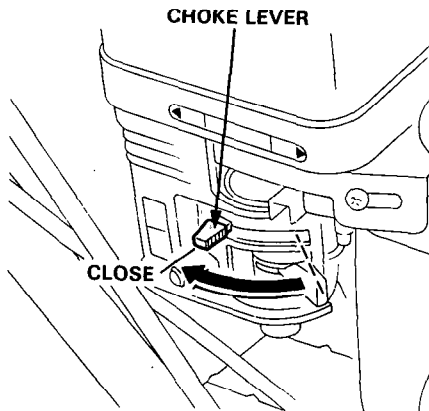

4. Pull the starter grip lightly until you feel resistance, then pull briskly.

CAUTION:

- Don't allow the rope to snap back; return it gently by hand. Otherwise, the starting mechanism might be damaged.
- Damage may result if the starter grip is pulled while the engine is running.

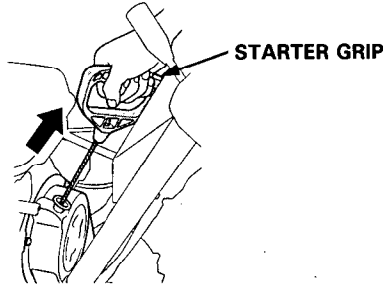

Push the starter button until the engine starts. (TAS, WAS Type)

CAUTION:

- Do not operate the starter for more than 1 minute. If the engine fails to start, release the button and allow the starter to cool for 15 minutes before operating it again.
- To avoid serious engine damage, never operate the starter while the engine is running.
- After the engine starts, disconnect the power cord from the electrical outlet first, and then from the switch box.

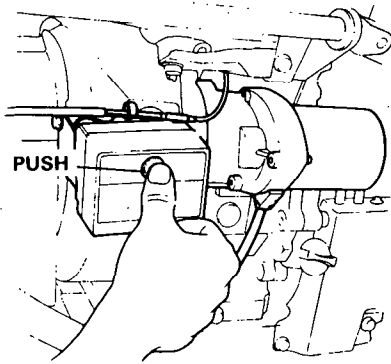

5. Let the engine warm up for several minutes. If the choke has been turned to the CLOSE position, return it gradually to the OPEN position as the engine warms up.

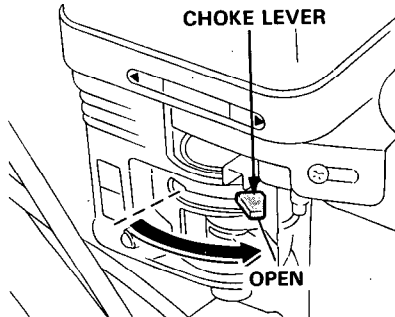

6. SNOWBLOWER OPERATION



WARNING Before operating this equipment you should read and understand the **POWER EQUIPMENT SAFETY** information on page 3, 4.

1. Move the throttle lever (p. 10) to the FAST position for normal operation.
2. Move the shift lever (p. 10) to select the desired drive speed.

(DRIVE SPEED WITH THROTTLE)
(LEVER IN THE FAST POSITION)

	Wheel type	Track type
1	0.43 m/s (0.9 mile/h)	0.28 m/s (0.6 mile/h)
2	0.74 m/s (1.6 mile/h)	0.47 m/s (1.0 mile/h)
3	1.01 m/s (2.2 mile/h)	1.10 m/s (2.4 mile/h)
R	0.68 m/s (1.5 mile/h)	0.74 m/s (1.6 mile/h)

CAUTION: Be sure to set the shift lever into the groove. Do not shift between forward and reverse speeds while the machine is in motion.

NOTE: Low speed (1) is recommended for removing deep or hard-packed snow.

3. Track model only — Use the height adjustment pedal (p. 14) to adjust the height and angle of the machine.
4. Adjust the chute direction (p. 12) and chute guide angle (p. 12).
5. Squeeze the auger clutch lever and drive clutch lever (p. 11) to propel the machine and commence snow clearing.

HIGH ALTITUDE OPERATION

At high altitude, the standard carburetor air-fuel mixture will be excessively rich. Performance will decrease, and fuel consumption will increase.

High altitude performance can be improved by installing a smaller diameter main fuel jet in the carburetor and readjusting the pilot screw. If you always operate the snowblower at altitudes higher than 6,000 feet above sea level, have your authorized Honda Snowblower dealer perform these carburetor modifications.

Even with suitable carburetor jetting, engine horsepower will decrease approximately 3.5% for each 1,000 foot increase in altitude. The affect of altitude on horsepower will be greater than this if no carburetor modification is made.

CAUTION: Operation of the snowblower at an altitude lower than the carburetor is jetted for may result in reduced performance, overheating, and serious engine damage caused by an excessively lean air/fuel mixture.

WARNING

- **Adjust the snow discharge chute to avoid hitting the operator, bystanders, windows, and other objects with thrown snow. Stay clear of the snow discharge chute while the engine is running.**
- **If the snow discharge chute becomes clogged, stop the engine and use a wooden stick to unclog it. Never put your hand into the snow discharge chute while the engine is running; serious personal injury could result.**

NOTE:

- To move the machine without engaging the snow-blowing mechanism, squeeze the drive clutch lever only. Do this when moving the machine to or from the area to be cleared.
- To engage the snow-blowing mechanism without using the drive mechanism, squeeze the auger clutch lever only. Do this if you wish to maneuver the machine manually while clearing snow.
- Squeeze both levers to propel the machine and clear snow simultaneously. When both levers are squeezed, the drive clutch lever locks the auger clutch lever down (p. 11). The auger clutch lever remains locked down so long as one hand continues to squeeze the drive clutch lever. Releasing the drive clutch lever then unlocks and releases the auger clutch lever.
- If the snow is deeper than the height of the auger, move the machine back and forth to remove snow gradually.
- For best efficiency, clear snow before it melts, refreezes and hardens.

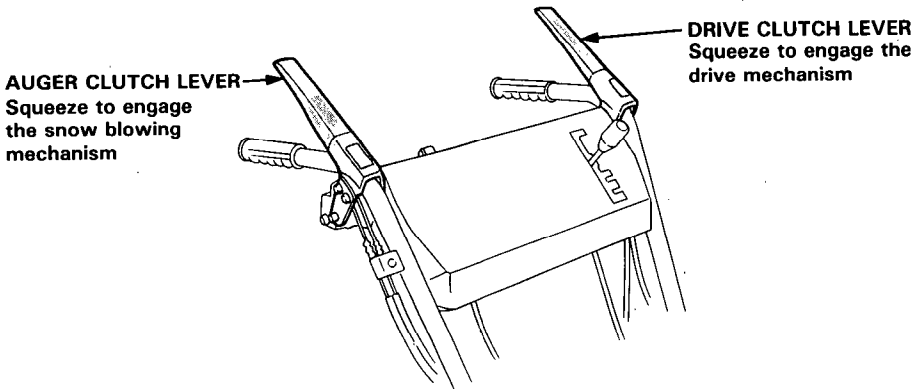

7. STOPPING THE ENGINE

To stop the engine in an emergency, turn the engine switch OFF immediately.

1. Turn the throttle lever to the SLOW position and turn the engine switch to the OFF position.

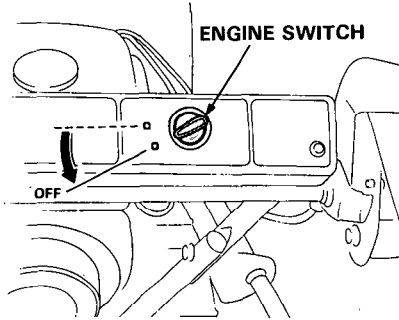

2. Turn the fuel valve to the OFF position.

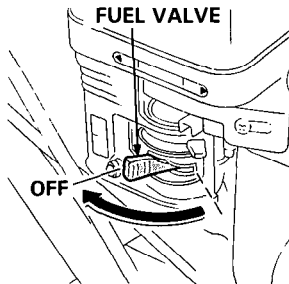

8. MAINTENANCE

The purpose of inspection and maintenance is to keep the snowblower in the best operating condition.

Inspect or service as scheduled in the table below.

WARNING

- Shut off the engine before performing inspection and maintenance, and disconnect the spark plug wire from the plug so the engine cannot be started.
- If the engine must be run, make sure the area is well ventilated. Exhaust gas contains poisonous carbon monoxide; exposure may cause loss of consciousness and may lead to death.

CAUTION:

- To avoid overturning, place the snowblower on a level surface before performing inspection and maintenance.
- Use only genuine HONDA parts or their equivalent.
Replacement parts which are not of equivalent quality may damage the snowblower.

MAINTENANCE SCHEDULE

ITEM	SERVICE PERIOD	EACH USE	First 20 hours operation	EVERY YEAR		EVERY 5 YEARS
				BEFORE OPERATION	BEFORE STORAGE	
Engine oil	Check level	○				
	Change		○	○		
Spark plug	Clean-Readjust			○		
Track	Adjust			○		
Auger and blower, auger housing lock bolt	Check			○		
Bolts, nuts, fasteners	Check			○		
Fuel strainer cup	Clean				○	
Fuel tank and carburetor	Drain				○	
Anti-corrosion oil	Apply oil				○	
Auger clutch cable	Adjust				○ (1) (2)	
Drive clutch cable	Adjust				○ (1) (2)	
Throttle cable	Adjust				○ (1) (2)	
Drive belt	Check-Readjust				○ (1) (2)	
Friction disc rubber	Check				○ (1) (2)	
Fuel line	Check (Replace if necessary)	Every 3 years (2)				
Valve clearance	Check-Readjust					○ (2)
Fuel tank and filter screen	Clean					○ (2)

NOTE: (1) These parts may require more frequent inspection and replacement under heavy use.
(2) These items should be serviced by an authorized Honda dealer, unless the owner has the proper tools and is mechanically proficient. See the Honda Shop Manual for service information.

TOOL KIT



SPARK PLUG WRENCH



WRENCH HANDLE

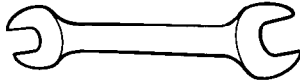

14 X 10 mm WRENCH

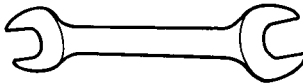

14 X 12 mm WRENCH

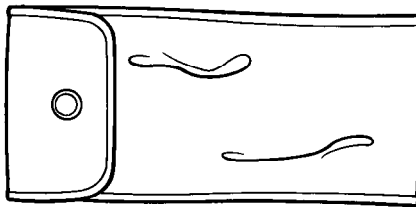

TOOL BAG

ENGINE OIL CHANGE

Drain the oil while the engine is still warm to assure rapid and complete draining.

1. Remove the drain plug and filler cap, and drain the oil. Retighten the plug securely.
2. Fill the crankcase with the recommended oil (see page 17) and check the level.

OIL CAPACITY: 0.6 l (0.63 US qt, 0.53 Imp qt)

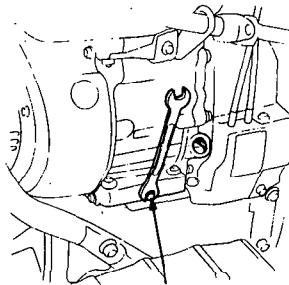

DRAIN BOLT

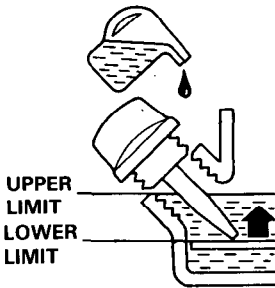

UPPER
LIMIT
LOWER
LIMIT

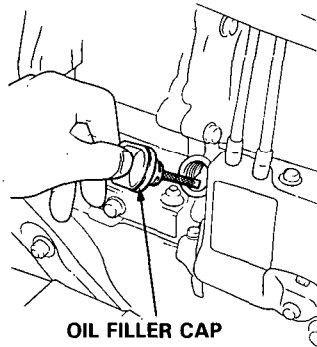

OIL FILLER CAP

CAUTION: Used motor oil may cause skin cancer if repeatedly left in contact with the skin for prolonged periods. Although this is unlikely unless you handle used oil on a daily basis, it is still advisable to thoroughly wash your hands with soap and water as soon as possible after handling used oil.

NOTE: Please dispose of used motor oil in a manner that is compatible with the environment. We suggest you take it in a sealed container to your local service station for reclamation. Do not throw it in the trash or pour it on the ground.

SPARK PLUG SERVICE

Recommended spark plug: BPR5ES (NGK), W16EPR-U (ND)

WARNING If the engine has been running, the muffler will be very hot. Be careful not to touch the muffler while it is hot.

To ensure proper engine operation, the spark plug must be properly gapped and free of deposits.

1. Remove the spark plug cap.
2. Clean any dirt from around the spark plug base.
3. Use the wrench supplied in the tool kit to remove the spark plug.
4. Visually inspect the spark plug, clean the spark plug with a wire brush if it is to be reused. Discard it if there is apparent wear or if the insulator is cracked or chipped.
5. Measure the plug gap with a feeler gauge.
0.7–0.8 mm (0.027–0.031 in)

Correct as necessary by bending the side electrode.

6. Thread the plug in by hand to prevent cross-threading.
7. Tighten a new spark plug 1/2 turn with the wrench to compress the washer.

If you are reusing a plug, it should only take 1/8–1/4 turn after the plug seats.

CAUTION:

- Use only the recommended spark plugs or equivalent. Spark plugs which have an improper heat range may cause engine damage.
- The spark plug must be securely tightened. An improperly tightened spark plug can become very hot and may damage the engine.

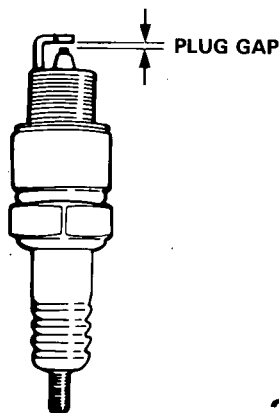
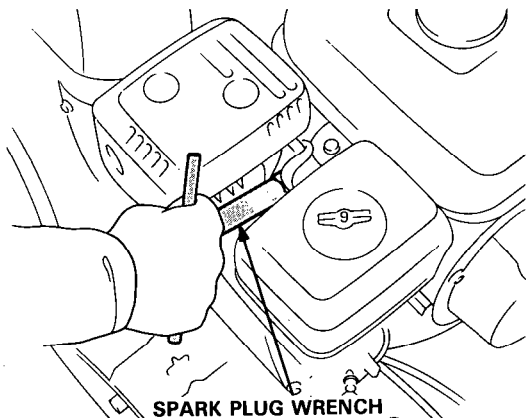

TRACK-ADJUSTMENT (Track model only)

Clean and thaw the tracks before adjustment. The tracks cannot be correctly adjusted if clogged with snow or debris, or coated with ice.

Check track deflection midway between the wheels. When correctly adjusted, the track will deflect 19–25 mm (3/4–1 in) when pressed with a force of 15 Kg (33 lb).

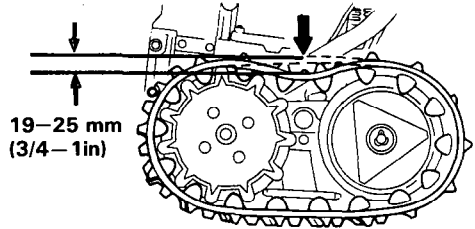

Adjustment:

1. Loosen the left and right tension bolt lock nuts at the rear axle, and turn the adjusting nuts to correctly tension both tracks.
2. After adjustment, retighten the lock nuts.

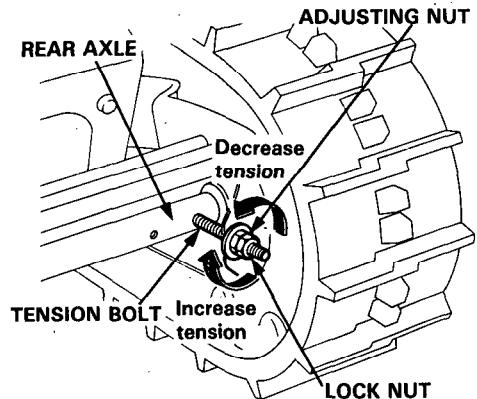

9. STORAGE

Before storing the snowblower for an extended period:

1. Be sure the storage area is free of excessive humidity and dust.
2. Drain the fuel—

WARNING

- Gasoline is extremely flammable and is explosive under certain conditions. Do not smoke or allow flames or sparks in the area.
- Do not drain the fuel tank when the exhaust system is hot.

- a. Turn the fuel valve ON.

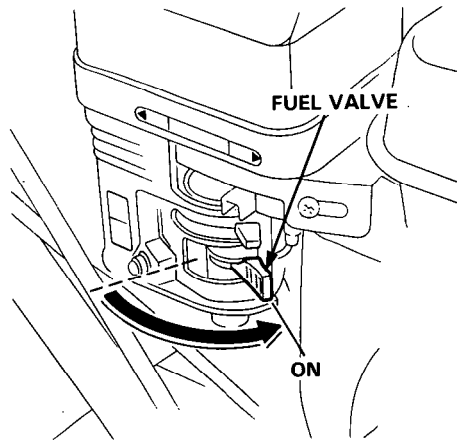

- b. Loosen the carburetor drain screw, and drain the gasoline into a suitable container. After draining, retighten the drain screw and turn the fuel valve OFF.

CARBURETOR DRAIN SCREW

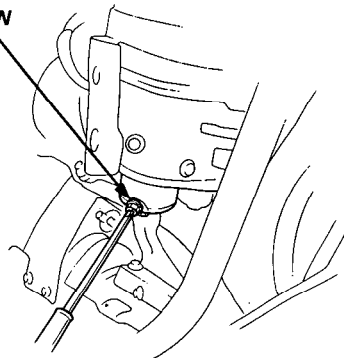

Remove the spark plug and pour three tablespoonsful of clean motor oil into the cylinder. Pull the starter rope slowly two or three times to distribute the oil. Reinstall the spark plug.

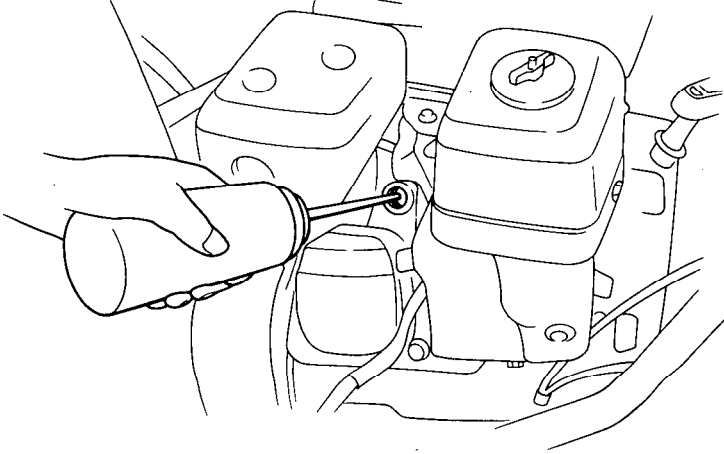

Pull the starter grip until resistance is felt. This closes the valves and protects the engine from internal corrosion.

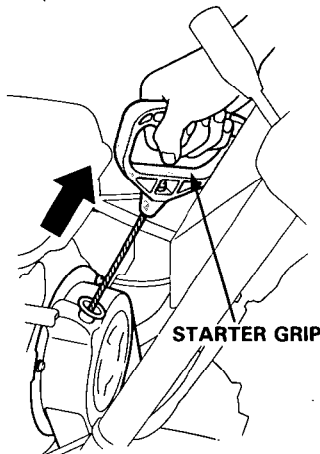

Apply oil to the following parts for lubrication and rust prevention.

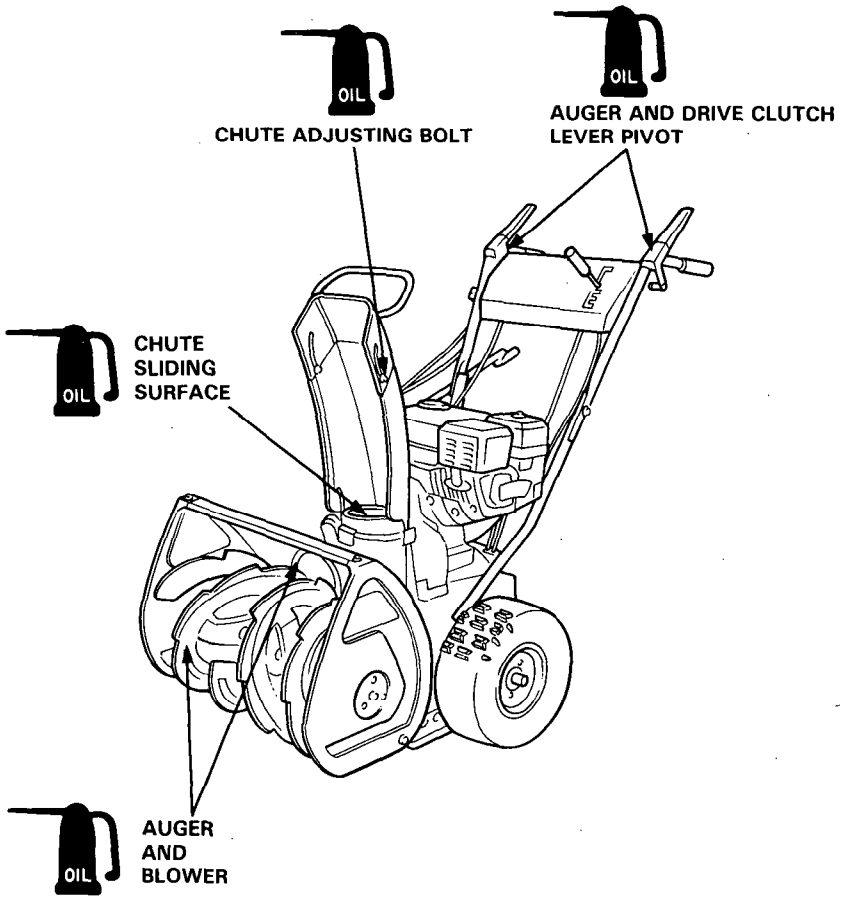

10. TROUBLESHOOTING

When the engine will not start:

1. Is there enough fuel?
2. Is the fuel valve on?
3. Is gasoline reaching the carburetor?

To check, loosen the drain screw with the fuel valve on. Fuel should flow freely.

WARNING If any fuel is spilled, make sure the area is dry before testing the spark plug or starting the engine. Spilled fuel or fuel vapor may ignite.

4. Is the engine switch on?
5. Is there a spark at the spark plug?
 - a. Remove the spark plug cap. Clean any dirt from around the spark plug base, then remove the spark plug.
 - b. Install the spark plug in the plug cap.
 - c. Turn the engine switch on.
 - d. Grounding the side electrode to any engine ground, crank the engine to see if sparks jump across the gap.
 - e. If there are no sparks, replace the plug.If OK, try to start the engine according to the instructions.
6. If the engine still does not start, take the snowblower to an authorized Honda snowblower dealer.

When the auger or blower will not operate:

Check the shear bolts and replace if broken off.

Secure the shear bolts with 6 mm nuts.

Three spare shear bolts are supplied with the snowblower.

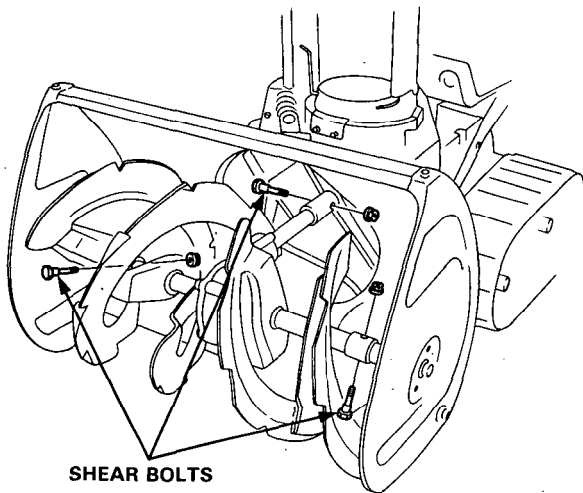

SHEAR BOLTS

11. SPECIFICATIONS

Engine

Model:	HONDA GX140
Maximum output:	5.5 HP/4200 r.p.m
Displacement:	144 cm ³ (8.8 cu. in)
Bore x stroke:	64 X 45 mm (2.5 X 1.8 in)
Starting method:	Recoil starter
Ignition system:	Transistorized magneto
Oil capacity:	0.6ℓ (0.63 US qt, 0.53 Imp qt)
Fuel tank capacity:	3.5ℓ (0.92 US gal, 0.77 Imp gal)
Spark plug:	BPR5ES (NGK), W16EPR-U (ND)

Frame

Items \ Type	Wheel type	Track type
Overall length	1310 mm (51.6 in)	1235 mm (48.6 in)
Overall width	663 mm (26.1 in)	550 mm (21.7 in)
Overall height	1029 mm (40.5 in)	975 mm (38.4 in)
Dry weight	81 kg (179 lb)	77 kg (170 lb)
Width of snow clearance	605 mm (23.8 in)	550 mm (21.7 in)
Height of snow clearance	470 mm (18.5 in)	415 mm (16.3 in)
Snow throwing distance (differs according to the kind of snow)	Max. 12 m (39.4 ft)	Max. 12 m (39.4 ft)
Clearing capacity	37 Ton/hour	35 Ton/hour
Continuous operating time	3 hours	3 hours

12. WARRANTY SERVICE

Owner Satisfaction

Your satisfaction and goodwill are important to your dealer and to us. All Honda warranty details are explained in the Distributor's Limited Warranty. Normally, any problems concerning the product will be handled by your dealer's service department. If you have a warranty problem that has not been handled to your satisfaction, we suggest you take the following action:

- Discuss your problem with a member of dealership management. Often complaints can be quickly resolved at that level. If the problem has already been reviewed with the Service Manager, contact the owner of the dealership or the General Manager.
- If your problem still has not been resolved to your satisfaction, contact:

American Honda Motor Co., Inc.
P.O. Box 50
Gardena, California 90247-0805
Telephone: (213) 604-2400

We will need the following information in order to assist you:

- Your name, address, and telephone number
- Product model and serial number
- Date of purchase
- Dealer name and address
- Nature of the problem

After reviewing all the facts involved, you will be advised of what action can be taken. Please bear in mind that your problem will likely be resolved at the dealership, using the dealer's facilities, equipment, and personnel, so it is very important that your initial contact be with the dealer.

Your purchase of a Honda product is greatly appreciated by both your dealer and American Honda Motor Co., Inc. We want to assist you in every way possible to assure your complete satisfaction with your purchase.

HONDA
HONDA MOTOR CO., LTD. TOKYO, JAPAN

31736601
00X31-736-6010

K2   5009012
PRINTED IN JAPAN