

Homelite®

ELECTRIC CHAIN SAW OWNER'S MANUAL

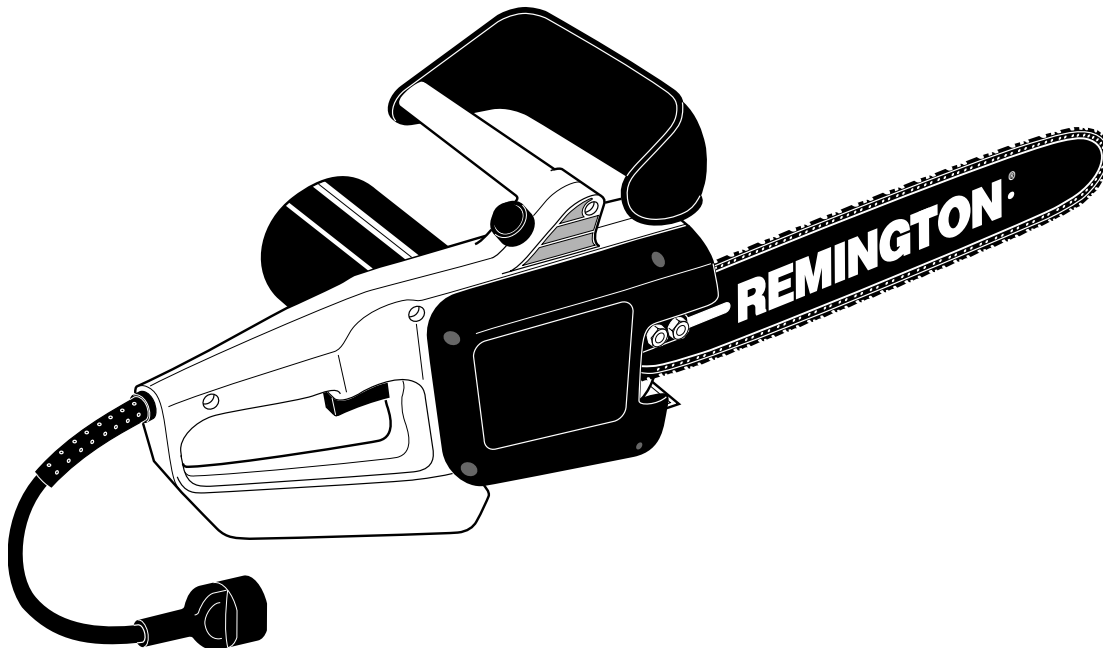

MODEL: UT13130

IMPORTANT: Read and understand this manual before assembling or operating this chain saw. Improper use of saw can cause severe injury. Keep this manual for future reference.



SAFETY WARNINGS

Make certain you read and understand all Safety Warnings on pages 2 and 3. Improper use of this chain saw can cause severe injury or death from fire, electrical shock, body contact with moving chain, or falling wood.

BEFORE OPERATING SAW

1. Read and understand this owner's manual before operating chain saw.
2. Watch what you are doing. Use common sense. Do not operate saw when you are tired.
3. Use chain saw for cutting wood only. Do not use chain saw for purpose not intended. Do not use for cutting plastic, masonry, etc.
4. Only well-instructed adults should operate chain saw. Never allow children to operate chain saw.
5. Use only electrical voltage noted on model plate of chain saw.
6. Use only extension cords marked for outdoor use. See page 8 for extension cord requirements.
7. Do not operate chain saw
 - while under the influence of alcohol, medication, or drugs
 - in rain or in damp or wet areas
 - where highly flammable liquids or gases are present
 - if saw is damaged, adjusted wrong, or not fully and securely assembled
 - if trigger does not turn saw on and off. Chain must stop moving when you release trigger. Have faulty switch replaced by authorized service center.
 - while in a hurry
 - while in tree or on a ladder unless trained to do so
8. Wear snug-fitting clothes when operating chain saw. Do not wear loose clothing or jewelry. They can get caught in moving saw chain.
9. Wear the following safety gear when operating chain saw.
 - heavy-duty gloves (wear rubber gloves when working outdoors)
 - steel-toed safety footwear with non-skid soles
 - eye protection such as safety glasses, goggles, or face screen
 - safety hard hat
 - ear muffers or ear plugs
 - hair covering to contain long hair
 - face or dust mask (if working in dusty areas)
10. Before cutting, always provide the following:
 - clear work area
 - secure footing
 - planned retreat path from falling tree
11. Inspect tree before cutting down. Make sure there are no dead limbs or branches that may fall on you.
12. To reduce the risk of electric shock, this saw has a polarized plug (one blade is wider than the other). This plug will fit in a polarized outlet only one way. If the plug does not fit fully in the outlet of your extension cord, reverse the plug. If it still does not fit, a polarized extension cord will be necessary. Do not change the plug in any way.

WHILE OPERATING SAW

1. Stay alert. Use common sense while operating chain saw.
2. Keep work area clean. Cluttered areas invite injuries.
3. Be aware of extension cord while operating chain saw. Be careful not to trip over cord. Keep cord away from chain and operator at all times.
4. Keep children, animals, and bystanders away from chain saw and extension cord. Only chain saw user should be in work area.
5. Do not cut down a tree unless you are trained or have expert help.
6. If two or more persons perform bucking and felling operations at the same time, provide plenty of distance between operations. Provide distance of at least twice the height of tree being felled.
7. Secure wood you are cutting by using clamps or chocks.
8. Grip chain saw firmly with both hands. Never operate chain saw with one hand. Never use hand guard as handle.
9. Keep finger off trigger until ready to make cut.
10. Before starting chain saw, make sure chain is not touching anything.
11. To guard against electrical shock, avoid

- body contact with grounded objects such as pipes, fences, and metal posts.
12. Keep all parts of body away from chain when saw is running.
13. Do not force chain saw while cutting. Apply light pressure. It will do the job better and safer at the rate for which it was intended.
14. Cut small brush and saplings with extreme care. Slender material may catch in chain and be whipped toward you. This could also pull you off balance.
15. When cutting limb or tree trunk that is under tension, use extreme caution. Be alert for wood springing back. When wood tension is released, limb could spring back and strike operator causing severe injury or death.
16. Carry chain saw from one place to another
 - with saw stopped and unplugged
 - by holding front handle (never use hand guard as handle)
 - with finger off trigger
 - with guide bar and chain to rear

 **WARNING: This product contains chemicals known to the State of California to cause cancer or birth defects, or other reproductive harm.**

 **WARNING: Some dust created by power sanding, sawing, grinding, drilling, and other construction activities contains chemicals known (to the state of California) to cause cancer, birth defects, or other reproductive harm. Some examples of these chemicals are:**

- lead from lead-based paints
- crystalline silica from bricks and cement and other masonry products
- arsenic and chromium from chemically-treated lumber

Your risk from these exposures varies, depending on how often you do this type of work. To reduce your exposure to these chemicals: work in a well ventilated area, and work with approved safety equipment, such as those dust masks that are specially designed to filter out microscopic particles.

SAFETY WARNINGS

KICKBACK

WARNING: Kickback may occur when the nose or tip of the guide bar touches an object, or when the wood closes in and pinches the saw chain in the cut. Tip contact in some cases may cause a lightning fast reverse reaction, kicking the guide bar up and back towards the operator. Pinching the saw chain along the top of the guide bar may push the guide bar rapidly back towards the operator. Either of these reactions may cause you to lose control of the saw which could result in serious injury to user.

Kickback Safety Devices On This Saw

This saw has a low-kickback chain and reduced kickback guide bar. Both items reduce the chance of kickback. Kickback can still occur with this saw.

Properly install front hand guard. This item can reduce injuries from kickback. Follow assembly instructions on page 6. Do not remove front hand guard. Do not replace front hand guard with substitute.

The following steps will reduce the risk of kickback.

- Use both hands to grip saw while saw is running. Use firm grip. Thumbs and fingers must wrap around saw handles.
- Keep all safety items in place on saw. Make sure they work properly.
- Do not overreach or cut above shoulder height.
- Keep solid footing and balance at all times
- Stand slightly to left side of saw. This keeps your body from being in direct line with chain.
- Do not let guide bar nose touch anything when chain is moving (see Figure 1).

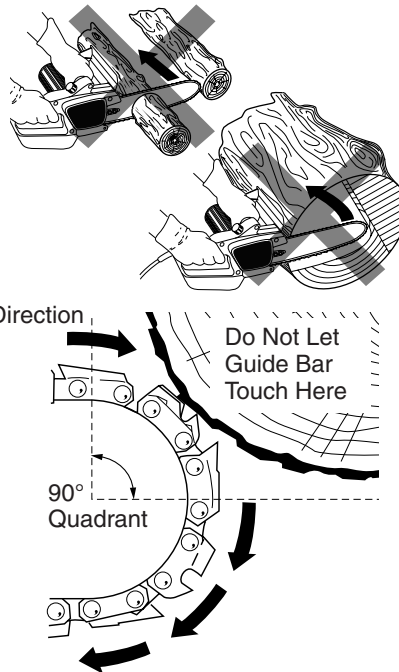

Figure 1 - Kickback Hazard Example: Do Not Let Nose of Guide Bar Touch Object While Chain is Moving

- Never try cutting through two logs at same time. Only cut one log at a time.
- Do not bury guide bar nose or try plunge cut (boring into wood using guide bar nose).
- Watch for shifting of wood or other forces that may pinch chain.
- Use extreme caution when reentering a previous cut.
- Use low-kickback chain and guide bar supplied with this chain saw. Only replace these parts with chains and guide bars listed in this manual.
- Never use dull or loose chain. Keep chain sharp with proper tension.
- Do not hand sharpen chain on automatic chain sharpening (Fast Sharp) models.

Saw Maintenance and Kickback Safety

Follow maintenance instructions in this manual. Proper cleaning of saw and chain and guide bar maintenance can reduce chances of kickback. Inspect and maintain saw after each use. This will increase the service life of your saw. **Note:** Even with proper sharpening, risk of kickback can increase with each sharpening.

MAINTENANCE AND STORAGE OF CHAIN SAW

1. Unplug chain saw from power source
 - when not in use
 - before moving from one place to another
 - before servicing
 - before changing accessories or attachments, such as saw chain and guard
2. Inspect chain saw before and after each use. Check saw closely if guard or other part has been damaged. Check for any damage that may affect operator safety or operation of saw. Check for alignment or binding of moving parts. Check for broken or damaged parts. Do not use chain saw if damage affects safety or operation. Have damage repaired by authorized service center.
3. Maintain chain saw with care.
 - Never expose saw to rain.
 - Keep chain sharp, clean, and lubricated for better and safer performance.
 - Follow steps outlined in this manual to sharpen chain.
 - Keep handles dry, clean, and free of oil and grease.
 - Keep all screws and nuts tight.
 - Inspect power cord often. If damaged, have repaired by authorized service center.
 - Never carry chain saw by power cord.
 - Never yank power cord to unplug it.
 - Keep power cord from heat, oil, and sharp edges.
 - Inspect extension cords often and replace if damaged.
4. When servicing, use only identical replacement parts.
5. When not in use, always store chain saw
 - in a high or locked place, out of children's reach
 - in a dry place
 - in a carrying case or with scabbard over guide bar

Keep this manual for reference. It is your guide to safe and proper operation of this chain saw.

ELECTRIC CHAIN SAW

CHAIN SAW NAMES AND TERMS

Bucking Process of cutting a felled tree or log into lengths.

Felling Process of cutting down a tree.

Felling Cut Final cut when felling a tree. Make this cut on opposite side of tree from notching cut.

Front Handle Located at front of saw body.

Front Hand Guard Shield between front handle and guide bar. Protects left hand while using saw.

Guide Bar Metal bar that extends from saw body. The guide bar supports and guides chain.

Guide Bar Nose Tip or end of guide bar.

Kickback Quick backward and upward motion of guide bar. Kickback may occur when tip of guide bar touches an object while chain is moving. The guide bar will kick up and back towards operator.

Limbing Process of cutting limb(s) from a felled tree.

Low-Kickback Chain Chain that reduces chance of kickback as required by ANS B175.1.

Normal Cutting Position Stance used while making bucking and felling cuts.

Notching Cut Notch cut in tree that directs fall of tree.

Oiler Control System for oiling guide bar and chain.

Power Head Chain saw without chain and guide bar. Also known as saw body.

Pushback (Kickback, Pinch) Rapid push-back of chain saw. Pushback may occur if chain along top of guide bar is pinched, caught, or contacts a foreign object.

Rear Handle Handle located at rear of saw body.

Reduced Kickback Guide Bar Guide bar that reduces chance of kickback.

Replacement Chain Chain that complies with ANS B175.1 when used with a specific saw. It may not meet ANS requirements when used with other saws.

Saw Chain (Chain) Loop of chain having cutting teeth for cutting wood. The motor drives chain. The guide bar supports chain.

Spiked Bumper (Spike) Pointed teeth at front of saw body beside guide bar. Keep spiked bumper in contact with wood when felling or bucking. It helps maintain position of saw while cutting.

Sprocket Toothed wheel that drives chain.

Switch Device that completes or interrupts electrical circuit to motor of saw.

Switch Linkage This device connects switch to trigger. It moves switch when you squeeze trigger.

Switch Lockout Device that reduces accidental starting of saw.

Trigger Device that turns saw on and off. Squeezing trigger turns saw on.

Releasing trigger turns saw off.

Trimming (Pruning) Process of cutting limb(s) from a living tree.

Undercut An upward cut from underside of log or limb. This is done while in normal cutting position and cutting with top of guide bar.

OWNER'S MANUAL

PRODUCT IDENTIFICATION

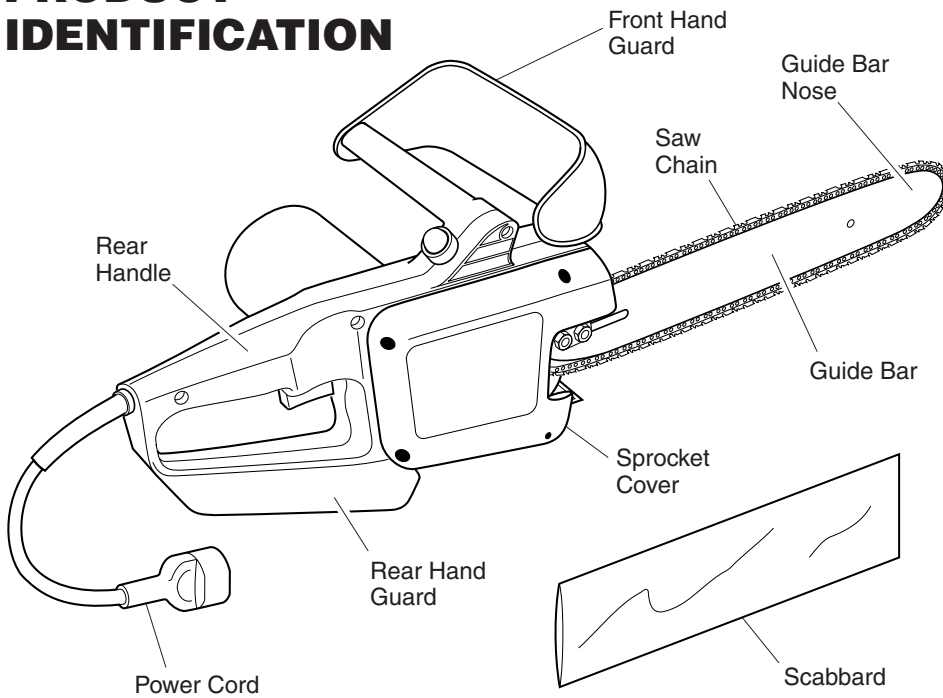

UNPACKING

1. Remove all items from carton.
2. Check all items for any shipping damage. If you find any damage or if any parts are missing, promptly inform dealer where you bought chain saw.

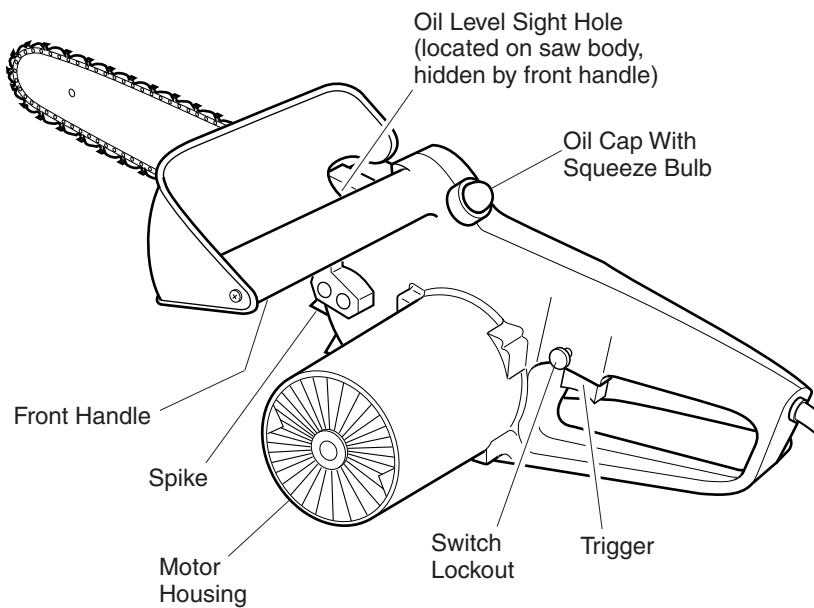

Figure 2 - Electric Chain Saw

ELECTRIC CHAIN SAW

ASSEMBLY

Note: Some models are pre assembled. Assembly is not needed on these models.

See *Saw Chain Tension Adjustment*, page 7.

⚠ WARNING: Cutting edges on chain are sharp. Use protective gloves when handling chain.

IMPORTANT: Do not clamp chain saw in vise during assembly.

The plastic hardware bag should include:

- two guide bar bolts
- two guide bar nuts
- one Phillips-head tapping screw
- automatic chain sharpener (Fast Sharp models only)

1. Lay chain out flat.
2. Install front hand guard onto saw body. Do this by pressing two mounting stand-outs on hand guard into hex-shaped holes in saw body (see Figure 3).
3. Insert tapping screw through hand guard and into saw handle. Tighten screw firmly.
4. Turn adjusting screw counterclockwise (see Figure 4). Continue to turn adjusting screw until adjusting block is to rear of adjusting plate.
5. Install guide bar onto saw body. Place rear of guide bar between adjusting plate and sprocket support.

IMPORTANT: Make sure to insert adjusting block into oval adjusting hole on guide bar.

6. Line up holes on sprocket support with center slot on guide bar and holes in saw body.

7. Insert guide bar bolts through front hand guard, saw body, center slot of guide bar, and sprocket support. Attach guide bar nuts to guide bar bolts.

IMPORTANT: Tighten guide bar nuts finger tight only. Make sure adjusting block is in oval adjusting hole on guide bar.

8. Place chain around drive sprocket, then along top groove of guide bar and around guide bar nose. *Note:* Make sure cutting edges of chain are facing the right direction. Position chain so cutting edges on top of guide bar face guide bar nose (see Figure 3).

⚠ CAUTION: Do not place chain on saw backwards. If chain is backwards, saw will vibrate badly and will not cut.

9. Adjust saw chain tension. Follow steps under *Saw Chain Tension Adjustment*, page 7.

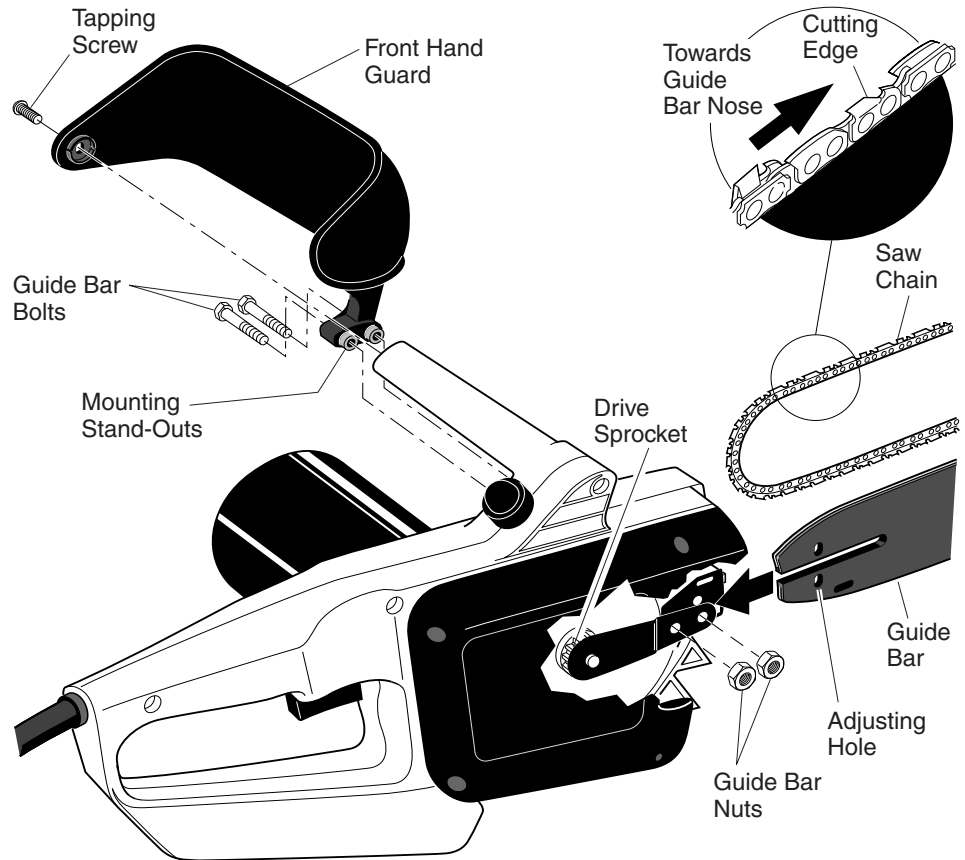

Figure 3 - Assembling Guide Bar, Chain, and Hand Guard

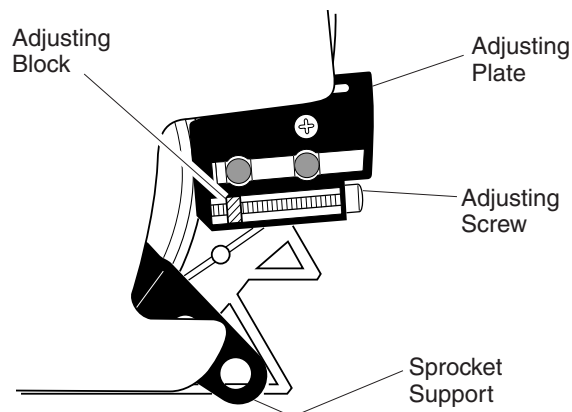

Figure 4 - Part Locations For Assembling Guide Bar

SAW CHAIN TENSION ADJUSTMENT

⚠ WARNING: Unplug chain saw from power source before adjusting saw chain tension.

⚠ WARNING: Cutting edges on chain are sharp. Use protective gloves when handling chain.

⚠ WARNING: Maintain proper chain tension always. A loose chain will increase the risk of kickback. A loose chain may jump out of guide bar groove. This may injure operator and damage chain. A loose chain will cause chain, guide bar, and sprocket to wear rapidly.

Note: For pre-assembled models, the saw chain tension is properly set at factory. A new chain will stretch. Check new chain after first few minutes of operation. Allow chain to cool down. Follow steps below to readjust saw chain tension.

1. Before adjusting chain, make sure guide bar nuts are only finger tight (see Figure 3, page 6). Also make sure adjusting block is in oval adjusting hole on guide bar (see Figures 3 and 4, page 6).
2. Turn adjusting screw clockwise until all slack is out of chain (see Figure 5). *Note:* There should be no gap between side links of chain and bottom of guide bar (see Figure 6).
3. Wearing protective gloves, move chain around guide bar. Chain should move freely. If chain does not move freely, loosen chain by turning adjusting screw counterclockwise.

4. After chain tension is correct, tighten guide bar nuts firmly. If not, guide bar will move and loosen chain tension. This will increase the risk of kickback. This can also damage saw. *Note:* A new chain will stretch. Check new chain after first few minutes of operation. Allow chain to cool down. Readjust chain tension.

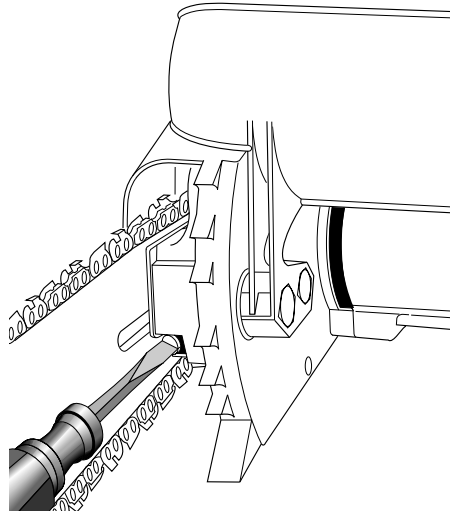

Figure 5 - Turning Adjusting Screw

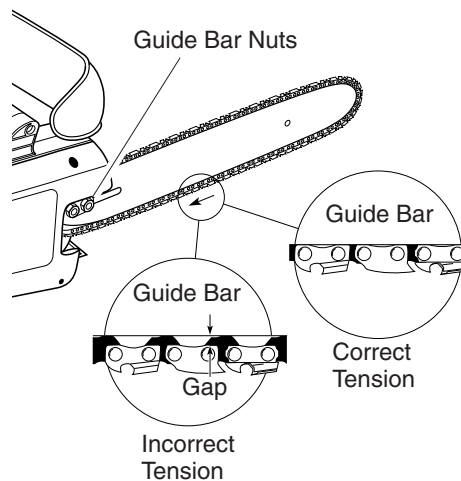

Figure 6 - Saw Chain Adjustment

FILLING OIL TANK

1. Remove oil cap.
2. Fill oil tank with SAE #30 motor oil. *Note:* For temperatures below 30°F, use SAE #10 oil. For temperatures above 75°F, use SAE #40 oil.
3. Replace oil cap at once. Tighten oil cap firmly for good seal. This will avoid oil seepage from tank.
4. Wipe off excess oil.

Note: It is normal for oil to seep when saw is not in use. Empty oil tank after each use to prevent seepage.

ELECTRIC CHAIN SAW

OPERATING CHAIN SAW

⚠ WARNING: Read and understand this owner's manual before operating this saw. Make certain you read and understand all *Safety Warnings*, pages 2 and 3. Improper use of this chain saw can cause severe injury or death from fire, electrical shock, or body contact with moving chain, or falling wood.

EXTENSION CORDS

Use proper extension cords with this saw. Use only extension cords marked for outdoor use. The cord must be marked with suffix W or W-A following the cord type designation. *Example:* SJTW-A or SJTW.

Use proper sized cord with this saw. Cord must be heavy enough to carry current needed. An undersized cord will cause voltage drop at saw. Saw will lose power and overheat. Follow cord size requirements listed below.

Cord Length	AWG Cord Size
25 feet	16 AWG
50 feet	16 AWG
100 feet	16 AWG
150 feet	14 AWG

Model: UT13130

Keep cord away from cutting area. Make sure cord does not catch on branches or logs during cutting. Inspect cords often. Replace damaged cords.

The extension cord may come undone from the power cord during use. To avoid this, make a knot with the two cords as shown in Figure 7 below.

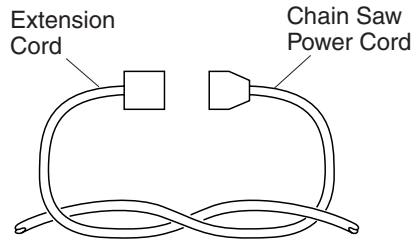

Figure 7 - Tying Extension Cord and Power Cord in Knot

OILING CHAIN

Always check oil level before using saw. To oil chain, press squeeze bulb on oil cap. Do not attempt to operate the oiler while cutting with the saw. Oil will feed onto guide bar and chain. Press squeeze bulb on oil cap at least once before each cut. Check oil level often by looking at oil sight level hole. Oil sight level hole is on left side of saw, between front handle and front hand guard.

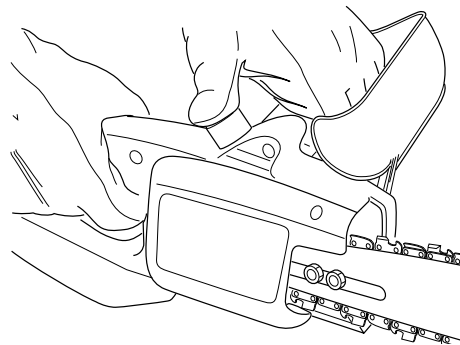

Figure 8 - Pressing Squeeze Bulb on Oil Cap to Oil Chain

CUTTING WITH THE CHAIN SAW

1. Connect saw to extension cord. Connect extension cord to power supply.
2. Make sure section of log to be cut is not laying on ground. This will keep chain from touching ground as it cuts through log. Touching ground with moving chain will dull chain.
3. Use both hands to grip saw. Always use left hand to grip front handle and right hand to grip rear handle. Use firm grip. Thumbs and fingers must wrap around saw handles (see Figure 9).
4. Make sure your footing is firm. Keep feet apart. Divide your weight evenly on both feet.
5. When ready to make a cut, press in switch lockout with right thumb and squeeze trigger (see Figure 9). This will turn saw on. Releasing trigger will turn saw off. Make sure saw is running at full speed before starting a cut.
6. When starting a cut, place moving chain against wood. Hold saw firmly in place to avoid possible bouncing or skating (sideways movement) of saw.
7. Guide saw using light pressure. Do not force saw. The motor will overload and can burn out. It will do the job better and safer at the rate for which it was intended.
8. Remove saw from a cut with saw running at full speed. Stop saw by releasing trigger. Make sure chain has stopped before setting saw down.
9. Practice until you can maintain a steady, even cutting rate.

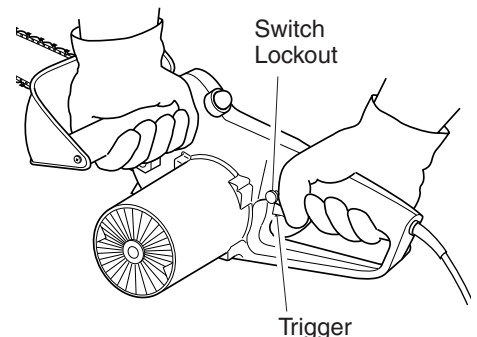

Figure 9 - Switch Lockout and Trigger Location

OPERATING CHAIN SAW

Continued

FELLING A TREE (Cutting Down a Tree)

⚠ WARNING:

- Avoid kickback. Kickback can result in severe injury or death. See *Kickback*, page 3 to avoid risk of kickback.
- Do not fell a tree without ample skill or expert help.
- Keep children, animals, and bystanders away from area when felling a tree.
- If two or more persons perform bucking and felling operations

⚠ WARNING: When felling a tree, be aware of your surroundings. Do not endanger any person, strike utility lines, or cause property damage. If tree strikes utility lines, contact utility company at once.

Felling is the process of cutting down a tree. Make sure your footing is firm. Keep feet apart. Divide your weight evenly on both feet. Follow directions below to fell a tree.

Before Felling a Tree

1. Before felling, inspect tree. Make sure there are no dead limbs or branches that may fall on you. Study natural lean of tree, location of larger branches, and wind direction. This will help you judge which way tree will fall.
2. Clear work area around tree.
3. Plan and clear a retreat path before felling. Make retreat path opposite to planned direction of fall of tree and at 45° angle (see Figure 10).
4. Remove dirt, stones, loose bark, nails, staples, and wire from tree where you will make felling cuts.
5. Stay on uphill side when felling tree. Tree could roll or slide downhill after falling.

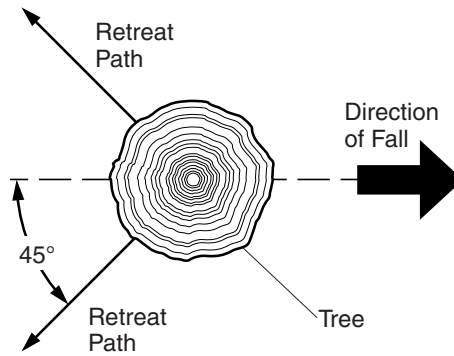

Figure 10 - Retreat Path From Tree

Felling Procedure

A) Felling Notch

A properly placed felling notch will determine direction tree will fall. Place felling notch on side of tree in direction you want tree to fall (see Figure 11). Follow directions below to create a felling notch.

1. Make lower notch cut as close to ground as possible. Hold saw so guide bar is horizontal. Cut 1/3 the diameter of tree trunk (see Figure 11). *Note:* Always make this horizontal lower notch cut first. If you make this cut second, tree can pinch chain or guide bar.
2. Start upper notch cut the same distance above first cut as first cut is deep.

Example: If lower notch cut is eight inches deep, start upper notch cut eight inches above it. Cut downward at 45° angle. The upper notch cut should meet end of lower notch cut (see Figure 11).

3. Remove tree trunk wedge created by notching cuts.

B) Felling Cut

1. Make felling cut two inches higher than lower notch cut and on opposite side of tree (see Figure 11). Keep felling cut parallel to lower notch cut.
2. Cut towards notch.

⚠ WARNING: Do not cut all the way through tree. Leave about two inches of tree diameter uncut directly behind felling notch (see Figure 11). This uncut portion acts as a hinge. The hinge helps keep tree from twisting and falling in wrong direction.

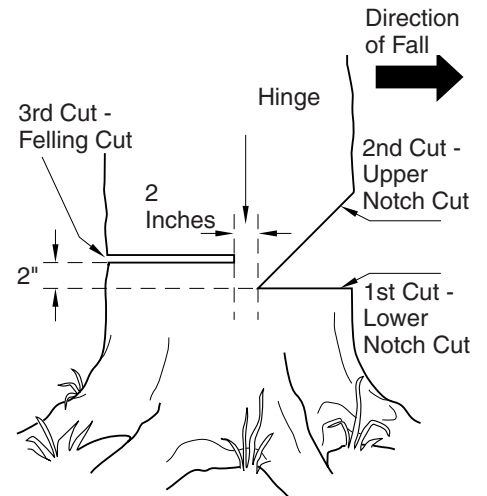

Figure 11 - Felling A Tree

3. As felling cut nears hinge, tree should begin to fall. *Note:* If needed, drive wedges into felling cut to control direction of fall. If tree settles back and pinches chain, drive wedges into felling cut to remove saw. Only use wedges made of wood, plastic, or aluminum. Never use wedge made of steel. This could cause kickback and damage to chain.
4. When tree begins to fall, quickly
 - remove saw from felling cut
 - release trigger to turn saw off
 - put saw down
 - exit area using retreat path

⚠ WARNING: Be alert for falling overhead limbs. Watch your footing while exiting area.

ELECTRIC CHAIN SAW

OPERATING CHAIN SAW

Continued

LIMBING A TREE

⚠ WARNING: Avoid kickback. Kickback can result in severe injury or death. See *Kickback*, page 3 to avoid risk of kickback.

⚠ WARNING: When cutting limb that is under tension, use extreme caution. Be alert for wood springing back. When wood tension is released, limb could spring back and strike operator causing severe injury or death.

Limbing is removing branches from a fallen tree. Make sure your footing is firm. Keep feet apart. Divide your weight evenly on both feet. Do not remove larger limbs under tree that support log off ground. Remove each limb with one cut (see Figure 12). Clear cut limbs from work area often. This will help maintain a safe work area.

Make sure you start your cut where limb will not pinch saw during cutting. To avoid pinching, start cut on freely hanging limbs from above limb. Start cut on limbs under tension from under limb. If pinch occurs, turn saw off, lift limb, and remove saw.

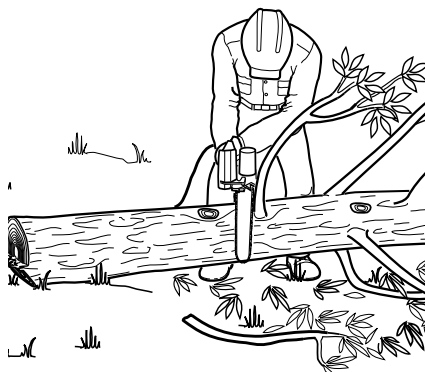

Figure 12 - Limbing A Tree

BUCKING A LOG

⚠ WARNING: Avoid kickback. Kickback can result in severe injury or death. See *Kickback*, page 3 to avoid risk of kickback.

⚠ WARNING:

- If on slope, make sure log will not roll down hill. Secure log by using wooden stakes. Drive wooden stakes into ground on downhill side of log. Stand on uphill side of log while cutting. Log may roll after cutting.
- Never try cutting through two logs at same time. This could increase the risk of kickback.
- While cutting log, never hold log with your hand, leg, or foot.
- While cutting log, never allow another person to hold log.
- Turn off and unplug saw before moving from one place to another.

Bucking a log is cutting a log into sections. Make sure your footing is firm. Keep feet apart. Divide your weight evenly on both feet. When possible, raise log or section off ground. Do this by using limbs, logs, chocks, etc.

When cutting through log, maintain control by reducing cutting pressure near end of cut. Do not relax your grip on chain saw handles. Do not let moving chain touch ground. Ground will dull moving chain. After cutting through log, release trigger to turn saw off before moving saw.

Follow directions below to buck a log.

Entire Length Of Log On Ground

Cut log from top (see Figure 13).

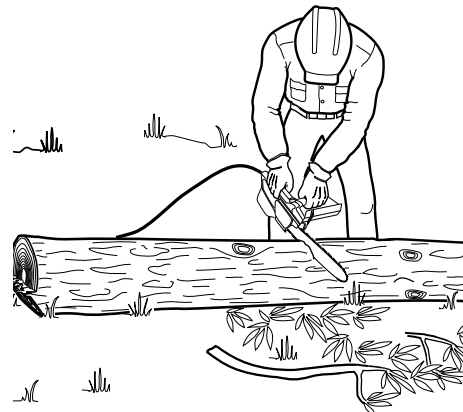

Figure 13 - Bucking Log With Entire Length On Ground

Log Supported On One End

1. Make first cut on underside of log (see Figure 14). Use top of guide bar to make this cut. Cut 1/3 through diameter of log. This cut will keep section from splintering when cut.
2. Make second cut directly above first cut. Cut down to meet first cut. This cut will keep log from pinching guide bar and chain.

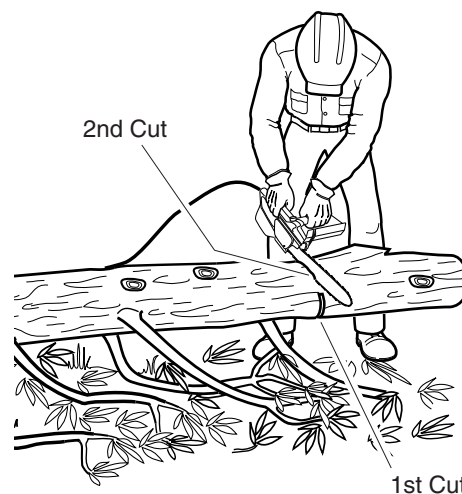

Figure 14 - Bucking Log When Log Is Supported On One End

OPERATING CHAIN SAW

Continued

Log Supported On Both Ends

1. Make first cut from above log (see Figure 15). Cut 1/3 through diameter of log. This cut will keep section from splintering when cut.
2. Make second cut on underside of log, directly under first cut. Use top of guide bar to make this cut. Cut up to meet first cut. This will keep log from pinching guide bar and chain.

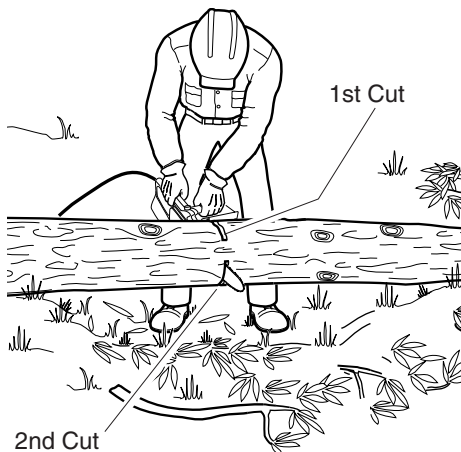

Figure 15 - Bucking Log When Log Is Supported On Both Ends

TRIMMING A TREE (Pruning)

⚠ WARNING: Avoid kickback. Kickback can result in severe injury or death. See *Kickback*, page 3 to avoid risk of kickback.

⚠ WARNING: Do not operate chain saw while

- in a tree
- on a ladder or any other unstable surface
- in any awkward position

You may lose control of saw causing severe injury.

⚠ WARNING: Do not cut limbs higher than your shoulders.

⚠ CAUTION: Seek professional help if facing conditions beyond your ability.

Trimming a tree is the process of cutting limbs from a living tree. Make sure your footing is firm. Keep feet apart. Divide your weight evenly on both feet. Follow directions below to trim a tree.

1. Make first cut six inches from tree trunk on underside of limb. Use top of guide bar to make this cut. Cut 1/3 through diameter of limb (see Figure 16).
2. Move two to four inches farther out on limb. Make second cut from above limb. Continue cut until you cut limb off.
3. Make third cut as close to tree trunk as possible on underside of limb stub. Use top of guide bar to make this cut. Cut 1/3 through diameter of stub.
4. Make fourth cut directly above third cut. Cut down to meet third cut. This will remove limb stub.

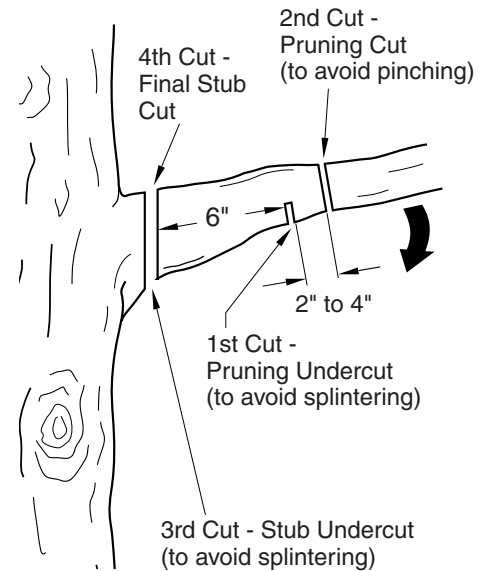

Figure 16 - Cutting A Limb

ELECTRIC CHAIN SAW

CLEANING AND MAINTENANCE

NOTICE: Below are instructions for servicing your chain saw. Any servicing not mentioned below should be done by an authorized service center.

CLEANING SAW BODY

⚠ WARNING: Unplug chain saw from power source before servicing. Severe injury or death could occur from electrical shock or body contact with moving chain.

⚠ WARNING: Cutting edges on chain are sharp. Use protective gloves when handling chain.

⚠ WARNING: When cleaning saw body,

- do not submerge saw in any liquids
- do not use products that contain ammonia, chlorine, or abrasives
- do not use chlorinated cleaning solvents, carbon tetrachloride, kerosene, or gasoline

Keep saw body clean. Use a soft cloth dampened with a mild soap and water mixture. Wipe saw body to clean.

CARE OF GUIDE BAR

Uneven bar wear causes most guide bar problems. Incorrect sharpening of chain cutter and depth gauge settings often cause this. When bar wears unevenly, it widens guide bar groove (see Figure 17). This causes chain clatter and rivet popping. Saw will not cut straight. Replace guide bar if this occurs.

Inspect guide bar before sharpening chain. A worn or damaged guide bar is unsafe. A worn or damaged guide bar will damage chain. It will also make cutting harder.

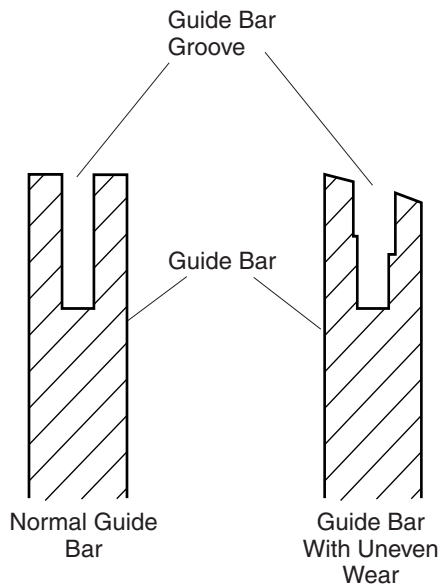

Figure 17 - Guide Bar Cross Section Showing Uneven Bar Wear

Normal Guide Bar Maintenance

1. Remove guide bar from chain saw.
2. Remove sawdust from guide bar groove periodically. Use putty knife or wire.
3. Clean oil slots after each day of use.
4. Remove burrs from sides of guide bar. Use flat file to make side edges square.

Replace guide bar when

- bar is bent or cracked
- inside groove of bar is badly worn

Note: When replacing guide bar, see *Replacement Parts and Accessories*, page 19, for proper bar.

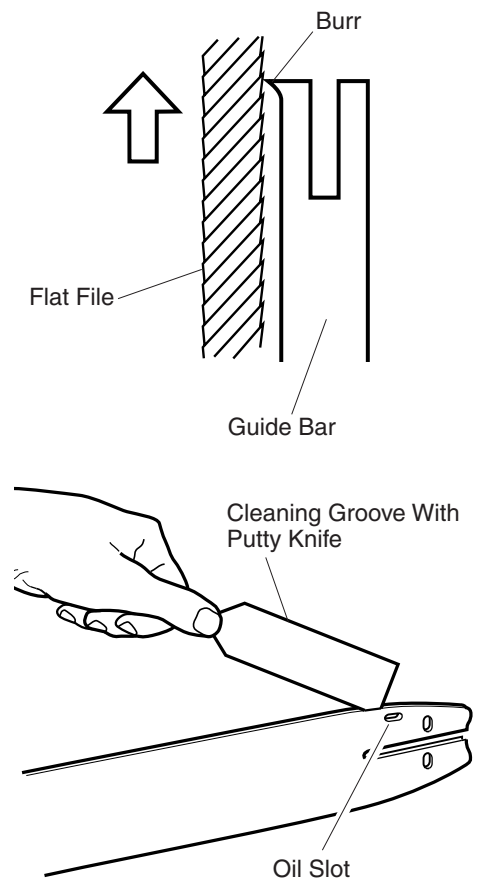

Figure 18 - Guide Bar Maintenance

CLEANING AND MAINTENANCE

Continued

SHARPENING SAW CHAIN

⚠ WARNING: Unplug chain saw from power source before servicing. Severe injury or death could occur from electrical shock or body contact with moving chain.

⚠ WARNING: Cutting edges on chain are sharp. Use protective gloves when handling chain.

Keep chain sharp. Your saw will cut faster and more safely. A dull chain will cause undue sprocket, guide bar, chain, and motor wear. If you must force chain into wood and cutting creates only sawdust with few large chips, chain is dull.

Items Needed to Sharpen Chain

Purchase these items from your local dealer, hardware store, or chain saw supplies outlet.

- 5/32" round file
- Depth gauge tool
- File guide
- Vise
- Medium sized flat file

Sharpening Cutters

Use file guide for 30° filing.

1. Adjust chain for proper tension (see *Saw Chain Tension Adjustment*, page 7).
2. Clamp guide bar in vise to hold saw steady. *Note:* Do not clamp chain.
3. Press 5/32" round file (attached to file guide) into groove between top plate and depth gauge on chain. File guide should rest on both top plate and depth gauge (see Figures 19 and 20). *Note:* File at midpoint of guide bar.
4. Hold file guide level. Make sure 30° mark on file guide is parallel to center of guide bar (see Figure 19). This will insure that you file cutters at 30° angle.
5. File from inside towards outside of cutter until sharp. Only file in this one direction (see Figure 19). *Note:* Two or three strokes with file should sharpen cutter.
6. After each cutter is sharpened, move chain forward to sharpen next cutter. File all cutters on one side of chain.
7. Move to other side of chain and repeat process.

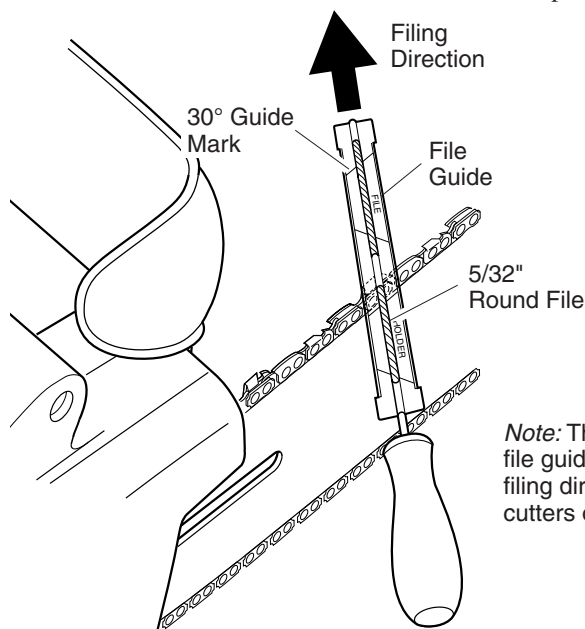

Note: This illustration shows file guide placement and filing direction for sharpening cutters on left side of chain.

Figure 19 - File and File Guide Placement On Chain

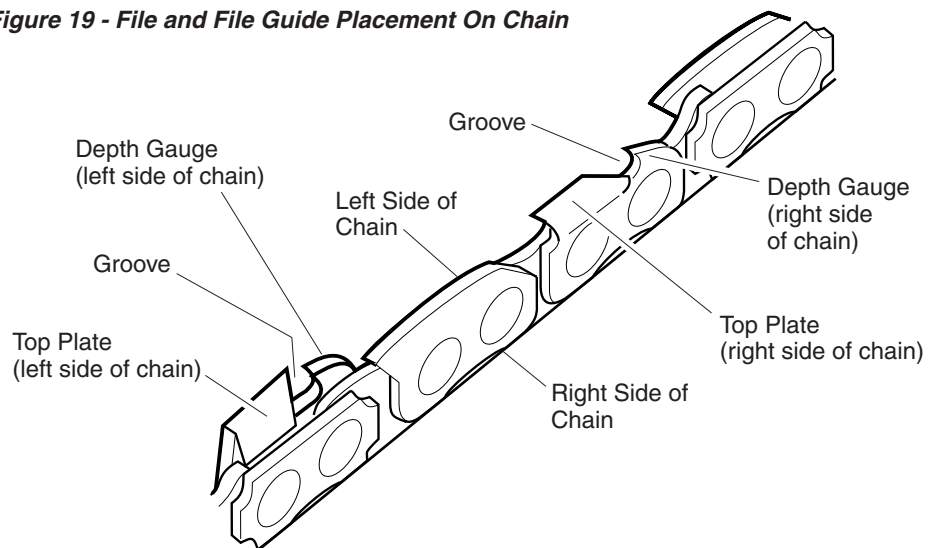

Figure 20 - Chain Part Locations

Continued

ELECTRIC CHAIN SAW

CLEANING AND MAINTENANCE

Continued

Filing Cutter Depth Gauges

The cutter depth gauge clearance is reduced as cutters are sharpened. After every second or third sharpening, reset cutter depth gauges.

1. Place depth gauge tool (.025") firmly across top of two cutters. Make sure depth gauge enters slot in depth gauge tool (see Figure 21).
2. Use medium flat file. File depth gauge level with depth gauge tool.
3. Remove depth gauge tool. With flat file, round off front corner of cutter depth gauge (see Figure 22).

After several hand filings, have authorized service center or sharpening service machine sharpen chain. This will insure even filing.

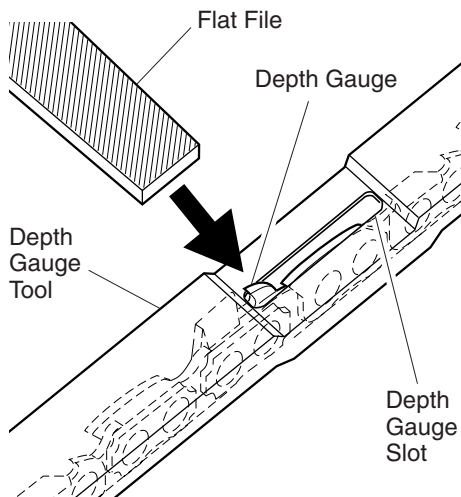

Figure 21 - Depth Gauge Tool On Chain

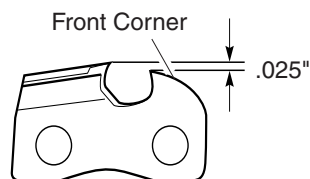

Figure 22 - Round Off Front Corner Of Depth Gauge

REPLACING SAW CHAIN

Replace chain when cutters are too worn to sharpen or when chain breaks. Only use replacement chain noted in this manual. Always include new drive sprocket when replacing chain. This will maintain proper driving of chain. **Note:** For proper chain and drive sprocket, see *Replacement Parts and Accessories*, page 19.

STORAGE

If storing saw for more than 30 days, follow steps below.

1. Drain oil tank.
2. Remove and clean guide bar and chain. Clean guide bar and chain by soaking in petroleum based solvent or mild soap and water mixture.
3. Dry guide bar and chain.
4. Place chain in container filled with oil. This will prevent rust.
5. Wipe a thin coating of oil over surface of guide bar.
6. Wipe off outside of saw body. Do this with soft cloth dampened with a mild soap and water mixture.
7. Store chain saw
 - in a high or locked place, out of children's reach
 - in a dry place
 - in a carrying case or with scabbard over guide bar

OWNER'S MANUAL

TROUBLESHOOTING

Note: For additional help, visit our technical service web site at www.desatech.com.

⚠ WARNING: Unplug chain saw from power source before servicing. Severe injury or death could occur from electrical shock or body contact with moving chain.

OBSERVED FAULT	POSSIBLE CAUSE	REMEDY
Saw runs, but does not cut	Chain assembled backwards on guide bar	See <i>Assembly</i> , page 6
Saw does not cut unless heavily forced. Cutting produces only sawdust with few large chips	Chain is dull	See <i>Sharpening Saw Chain</i> , page 13
Saw runs slow. Saw stalls easily	Low power supply voltage	Extension cord wire size too small. See <i>Extension Cords</i> , page 8
Motor of saw does not run when you squeeze trigger	<ol style="list-style-type: none">1. Switch lockout not pressed in to release trigger2. Extension cord connections loose3. Open line fuse or circuit breaker4. Bad motor brushes5. Open wiring circuit on saw	<ol style="list-style-type: none">1. Press in switch lockout before squeezing trigger2. Check cord connections3. Check line fuse or circuit breaker4. See authorized service center5. See authorized service center
Motor of saw runs, but chain does not move	Gear train failure	See authorized service center
Chain does not get oil	<ol style="list-style-type: none">1. Clogged oil slot in guide bar2. Oil is too thick	<ol style="list-style-type: none">1. Remove guide bar and clean oil slot2. Use correct weight of oil. See <i>Filling Oil Tank</i>, page 7
Chain comes off guide bar	<ol style="list-style-type: none">1. Chain is loose2. Guide bar and chain not assembled right	<ol style="list-style-type: none">1. Tighten chain. See <i>Saw Chain Tension Adjustment</i>, page 72. See <i>Assembly</i>, page 6
Saw smokes	Saw damaged. Do not use saw	See authorized service center
Saw leaks oil	Oil cap is not secure	Tighten oil cap. <i>Note:</i> Empty oil tank when not in use

ELECTRIC CHAIN SAW

ILLUSTRATED PARTS BREAKDOWN

UT13130

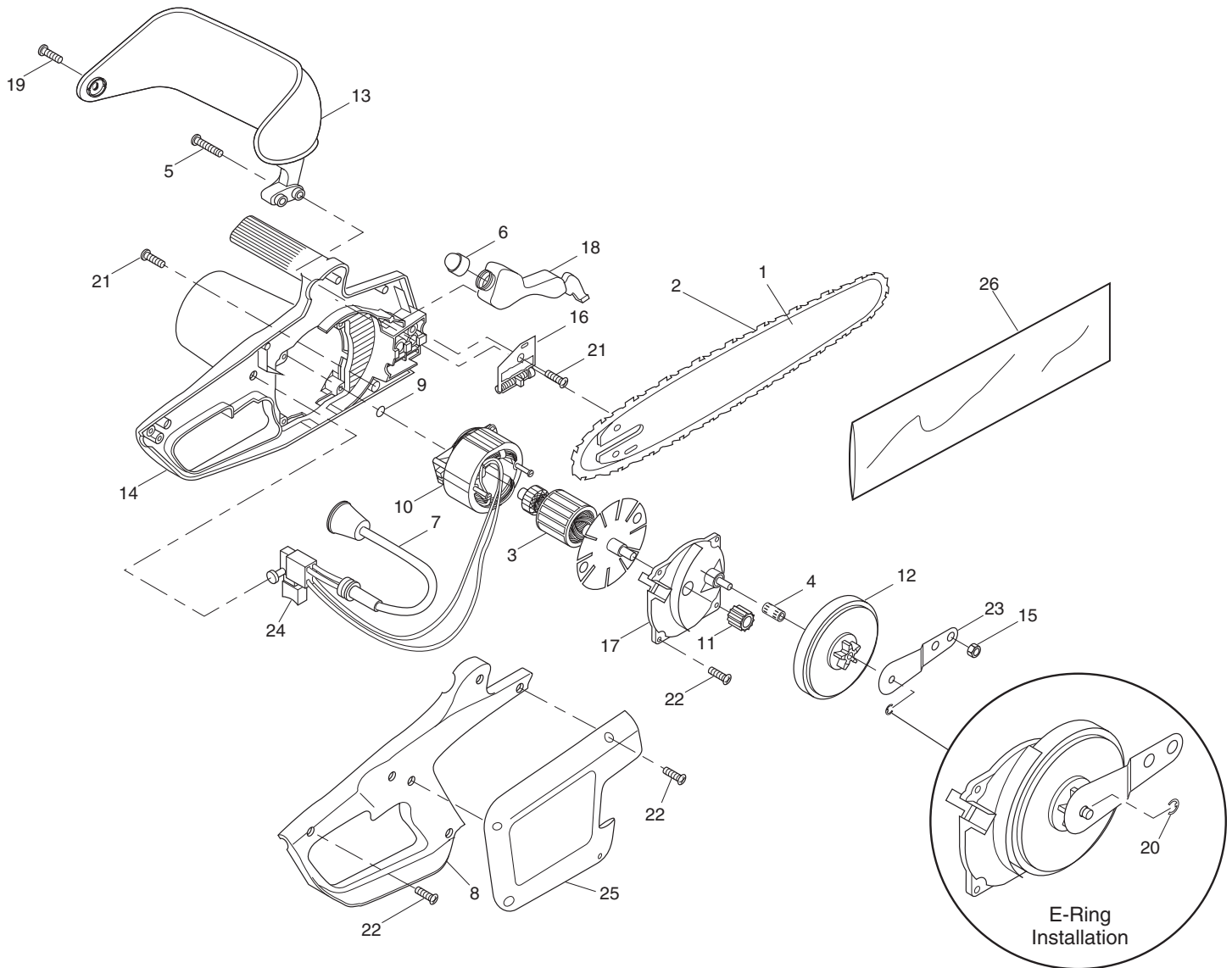

OWNER'S MANUAL

PARTS LIST

UT13130

This list contains replaceable parts used in your chainsaw. When ordering parts, be sure to provide the correct model and serial numbers (from the model plate), then the part number and description of the desired part.

KEY NO.	PART NO.	DESCRIPTION	QTY.
1	14SB	Guide Bar, 14"	1
2	14SC	Saw Chain	1
3	107481-01	Armature Assembly	1
4	075676	Sprocket Roller Bearing	1
5	107319-01	Hex-Head Bolt	2
6	107512-01	Cap & Bulb Assembly	1
7	099829-01	Cord	1
8	077399-14	Side Cover, Black	1
9	076105	Thrust Disk	1
10	107482-01	Field & Brush Assembly	1
11	059606	Drive Gear	1
12	107713-01	Internal Gear	1
13	106809-02	Front Hand Guard	1
14	079089-07	Motor Housing, Black	1
15	NPC-4C	Hex Nut	2
16	077115	Adjusting Plate Assembly	1
17	075887	Bearing Plate	1
18	079086-02	Oil Reservoir	1
19	097403-01	Pan-Head Screw	1
20	108120-01	E-Ring	1
21	076906	Flat-Head Tap Screw	2
22	107708-01	Pan-Head Tap Screw	10
23	077143	Sprocket Support	1
24	077525S	Lock-Off Switch	1
25	106810-01	Sprocket Cover, Black	1
26	079963-04	Scabbard	1

PARTS CENTRALS

Ray's Portable Heater Service

3191 Myers Road
Camino, CA 95709-9550
530-644-7716

Tool & Equipment

5 Manila Drive
Hamden, CT 06514-0322
203-248-7553
1-800-397-7553

Grainger Parts Operations

1657 Shermer Road
Northbrook, IL 60062-5362
708-498-5900
1-800-323-0620
www.grainger.com

Portable Heater Parts

342 North County Road 400 East
Valparaiso, IN 46383-9704
219-462-7441
1-800-362-6951
www.portableheaterparts.com
sales@portableheaterparts.com
techservice@portableheaterparts.com

FBD

1349 Adams Street
Bowling Green, KY 42103-3414
270-846-1199
1-800-654-8534
franktalk@aol.com

Lyons & Lyons Sales Co. Inc.

Glen Arm Road
Glen Arm, MD 21057-9454
301-665-6500
1-800-333-5966
lyonsco@erols.com

Master Part Distributors

1251 Mound Avenue NW
Grand Rapids, MI 49504-2672
616-791-0505
1-800-446-1446
www.masterparts.net

Hance Distributors, Inc.

12795 16th Avenue North
Plymouth, MN 55441-4556
763-559-2299
www.hanceco.com

Automotive Equipment Service

3117 Holmes
Kansas City, MO 64109-1716
816-531-9144
1-800-843-3546
www.aes-lawnparts.com

Bowden Electric Motor Service

1681 S. Wesleyan Blvd.
Rocky Mount, NC 27803
252-446-4203

East Coast Energy

10 East Route 36
West Long Branch, NJ 07764-1501
1-800-755-8809

Forrest Lytle and Sons, Inc.

740 West Galbraith Road
Cincinnati, OH 45231-6002
513-521-1464

Bortz Chain Saw Shop

Road #2, Box 64A
Oley, PA 19547-9412
610-987-6452

21st Century

2950 Fretz Valley Road
Perkasie, PA 18944-4034
215-795-0400
1-800-325-4828

La Porte's

2444 N 5th Street
Hartsville, SC 29550-7704
843-332-0191

MTA Distributors

555 Hickory Hills Blvd.
Nashville, TN 37189-9244
615-299-8777
1-800-264-0225

Webbs Appliance Center

1519 Church Street
Nashville, TN 37203-3004
615-329-4079
1-800-899-4079

Industrial Hardware

4109 Bainbridge Blvd.
Chesapeake, VA 23324-1403
757-543-2232
1-800-788-0008
catatem@erols.com

Mills Lawn and Garden

4750-B Baxter Road
Virginia Beach, VA 23462
757-490-7001
www.mills-parts.com

Tuco Industrial Products

5223 180th Street SW
Suite 4A-1
Lynnwood, WA 98037-4506
425-743-9533
1-800-735-1268
www.tucoheat.com

OWNER'S MANUAL

TECHNICAL SERVICE

You may have further questions about assembling, operating, or maintaining this product. If so, you can visit our Technical Service web site at www.desatech.com or contact our Technical Service Department at 1-800-858-8501 (English Only). You may also write to:

DESA Power Tools
ATTN: Technical Service Specialty Products
P.O. Box 90004
Bowling Green, KY 42102-9004

When contacting DESA Power Tools, have ready

- Your Name
- Your Address
- Your Phone Number
- Model Number of Product
- Date of Purchase (Include copy of receipt for written requests).

REPLACEMENT PARTS AND ACCESSORIES

 **WARNING: Use only replacement parts and accessories described in this manual. Use of other parts or accessories could damage saw or injure operator.**

For original replacement parts and accessories, contact your nearest Authorized Dealer or Authorized Service Center for this product. If they can not supply the part or accessory, contact your nearest Parts Central listed on page 18. Each Authorized Dealer, Authorized Service Center, and Parts Central is independently owned and operated.

See pages 16 and 17 for an Illustrated Parts List.

If you need additional referral information, contact our Technical Service Department (see *Technical Service*).

In Canada call 1-800-561-3372 for parts information.

UT13130

Part Number	Description
14SB	Guide bar, 14"
14SC	Chain, 14"
107713-01	Drive sprocket

General

Part Number	Description
079963-04	Plastic scabbard, 14"
106809-02	Hand Guard
077155	Adjusting Plate Assy.

REPAIR SERVICE

Note: Only use original replacement parts. This will protect your warranty coverage for parts replaced under warranty.

Each Authorized Service Center is independently owned and operated.

WARRANTY SERVICE

If product requires warranty service, return it to nearest Authorized Service Center. You must show proof of purchase. If faulty materials or workmanship caused damage, we will repair or replace product without charge. *Note:* Normal wear, misuse, abuse, neglect, or accidental damage is not covered under warranty.

NON-WARRANTY SERVICE

If product requires service, return it to nearest Authorized Service Center. Repairs will be billed to you at regular repair list prices.

For additional Service Center or warranty information, call 1-800-858-8501 or visit our Technical Service web site at www.desatech.com.

WARRANTY INFORMATION

HOMELITE BRAND ELECTRIC CHAIN SAW LIMITED WARRANTIES

NEW PRODUCTS

Standard Warranty

DESA Power Tools warrants this new product and any parts thereof to be free from defects in material and workmanship for a period of one (1) year from the date of first purchase from an authorized dealer provided the product has been maintained and operated in accordance with DESA Power Tools' warnings and instructions.

FACTORY RECONDITIONED PRODUCTS

Limited Warranty

DESA Power Tools warrants factory reconditioned products and any parts thereof to be free from defects in material and workmanship for 90 days from the date of first purchase from an authorized dealer provided the product has been installed, maintained and operated in accordance with DESA Power Tools' warnings and instructions.

TERMS COMMON TO ALL WARRANTIES

The following terms apply to all of the above warranties:

- Always specify model number when contacting the manufacturer. To make a claim under this warranty the bill of sale or other proof of purchase must be presented.
- This warranty is extended only to the original retail purchaser when purchased from an authorized dealer.
- This warranty covers the cost of part(s) required to restore this product to proper operating condition and an allowance for labor when provided by a DESA Power Tools Authorized Service Center. Warranty parts must be obtained through authorized dealers of this product and/or DESA Power Tools who will provide original factory replacement parts. Failure to use original factory replacement parts voids this warranty.
- Travel, handling, transportation, diagnostic, material, labor and incidental costs associated with warranty repairs, unless expressly covered by this warranty, are not reimbursable under this warranty and are the responsibility of the owner.
- Excluded from this warranty are products or parts that fail or become damaged due to misuse, accidents, lack of proper maintenance, tampering, or alterations.
- Excluded from this warranty are products purchased for commercial, industrial or rental usage.
- This is DESA Power Tools' exclusive warranty, and to the full extent allowed by law; this express warranty excludes any and all other warranties, express or implied, written or verbal and limits the duration of any and all implied warranties, including warranties of merchantability and fitness for a particular purpose to one (1) year on new products and 90 days on factory reconditioned products from the date of first purchase. DESA Power Tools makes no other warranties regarding this product.
- DESA Power Tools' liability is limited to the purchase price of the product, and DESA Power Tools shall not be liable for any other damages whatsoever under any circumstances including indirect, incidental, or consequential damages.
- Some states do not allow limitations on how long an implied warranty lasts or the exclusion or limitation of incidental or consequential damages, so the above limitation or exclusion may not apply to you.
- This warranty gives you specific legal rights, and you may also have other rights which vary from state to state.

For information about this warranty contact:



P.O. Box 90004
Bowling Green, KY 42102-9004
www.desatech.com



82 Akron Road
Toronto, Ontario
M8W 1T2
1-800-561-3372
Fax: 1-800-561-8003

Model _____

Date Purchased _____

120693-01
Rev. A
11/06