

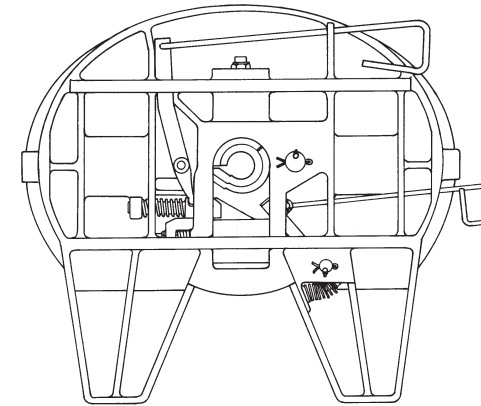

Troubleshooting and Rebuilding Procedures for XA-2081 SERIES Fifth Wheel Top Plates

XA-2081-DA
2" SAE Kingpin (Rebuild Kit RK-65012)



XA-2081-OA
3 1/2" SAE Kingpin (Rebuild Kit RK-65013)

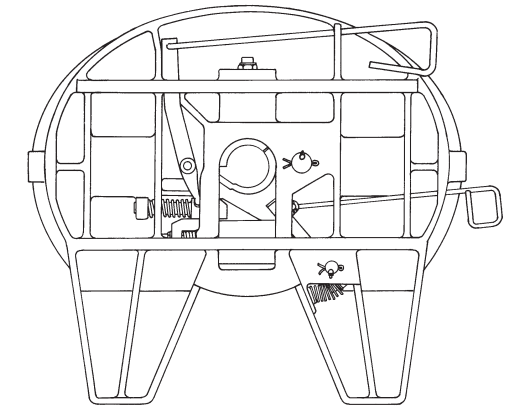

TROUBLE SHOOTING HINTS

Fifth Wheel is Hard to Hook Up to Trailer:

✓	POSSIBLE CAUSE	REMEDY
<input type="checkbox"/>	The trailer may be too high; the kingpin is not entering the locks properly.	Lower the trailer landing gear.
<input type="checkbox"/>	Locks are closed.	Pull the secondary and primary release handles to the unlocked position and pry the hinged lock open.
<input type="checkbox"/>	Accumulated rust or grime interfering with the lock operation.	Spray a light lubricant or diesel fuel on all moving parts including the release handle and operate several times.
<input type="checkbox"/>	The locks are adjusted too tightly.	Check lock adjustments in accordance with the procedure in this manual.
<input type="checkbox"/>	Bent release handle or kingpin or damaged bolster plate may be interfering with lock movement.	Check the kingpin with a Holland TF-0110 Kingpin Gage and bolster plate with a 48" straightedge. Repair/replace as required. The kingpin can be inspected in accordance with SAE J2228.
<input type="checkbox"/>	The locks may be damaged.	Inspect and replace if required following the procedures in this manual.
<input type="checkbox"/>	The fifth wheel may need rebuilding.	Follow the procedures contained in this manual using the appropriate rebuilding kit.
<input type="checkbox"/>	Using lube plate with wrong kingpin length.	See Holland Service Bulletin XL-SB4.

Fifth Wheel is Hard to Unhook from Trailer:

✓	POSSIBLE CAUSE	REMEDY
<input type="checkbox"/>	The secondary lock is not released.	Pull the secondary lock release handle and lift up to engage the handle lug with the top plate casting.
<input type="checkbox"/>	The tractor may be putting pressure against locks.	Back the tractor into the trailer to relieve the pressure and lock the tractor brakes before pulling the release handle.
<input type="checkbox"/>	Rust or grime on the locking mechanism.	Spray a light lubricant or diesel fuel on all moving parts including the release handle and operate several times.
<input type="checkbox"/>	Bent kingpin or damaged bolster plate.	Check the kingpin with a Holland TF-0110 Kingpin Gage and bolster plate with a 48" straightedge. Repair/replace as required. The kingpin can be inspected in accordance with SAE J2228.
<input type="checkbox"/>	Fifth wheel locks may be adjusted too tight.	Check the lock adjustment in accordance with procedures in this manual.
<input type="checkbox"/>	The release handle will not stay out.	Pull the release handle out and up, then release.
<input type="checkbox"/>	The release handle will not stay out; pops off lug.	Replace release handle.
<input type="checkbox"/>	The release handle must be held out when uncoupling.	Build up release handle lug to hold out further or replace release lever (15) or release handle (16).
<input type="checkbox"/>	Using lube plate with wrong kingpin length.	See Holland Service Bulletin XL-SB4.
<input type="checkbox"/>	Long plunger.	Pull the release handle to the fully extended position and hold it while someone else attempts to uncouple. If the locks do not open under this condition, close the swinging lock partially and grind 1/16" of the tip of the swinging lock. Round off after grinding.

NOTE: After the fifth wheel is unlocked and moves freely from the kingpin, it is normal for the release handle to return to the "in" position.



GO THE DISTANCE.
HOLLAND USA, INC.
1950 Industrial Blvd. • P.O. Box 425 • Muskegon, MI 49443-0425
Phone 888-396-6501 • Fax 800-356-3929
www.thehollandgroupinc.com

Copyright © September 2002 • The Holland Group, Inc.

Holland USA, Inc. Facilities:	Holland International, Inc.	Holland Hitch of Canada, Ltd.	Holland Equipment, Ltd.	Holland Hitch Western, Ltd.
Denmark, SC Dumas, AR Holland, MI Muskegon, MI	Warrenton, MO Whitehouse Station, NJ Wylie, TX	Holland, MI Phone: 616-396-6501 Fax: 616-396-1511	Woodstock, Ontario • Canada Phone: 519-537-3494 Fax: 800-565-7753	Norwich, Ontario • Canada Phone: 519-863-3414 Fax: 519-863-2398
			Surrey, British Columbia • Canada Phone: 604-574-7491 Fax: 604-574-0244	

Ph: 888-396-6501 Fax: 800-356-3929

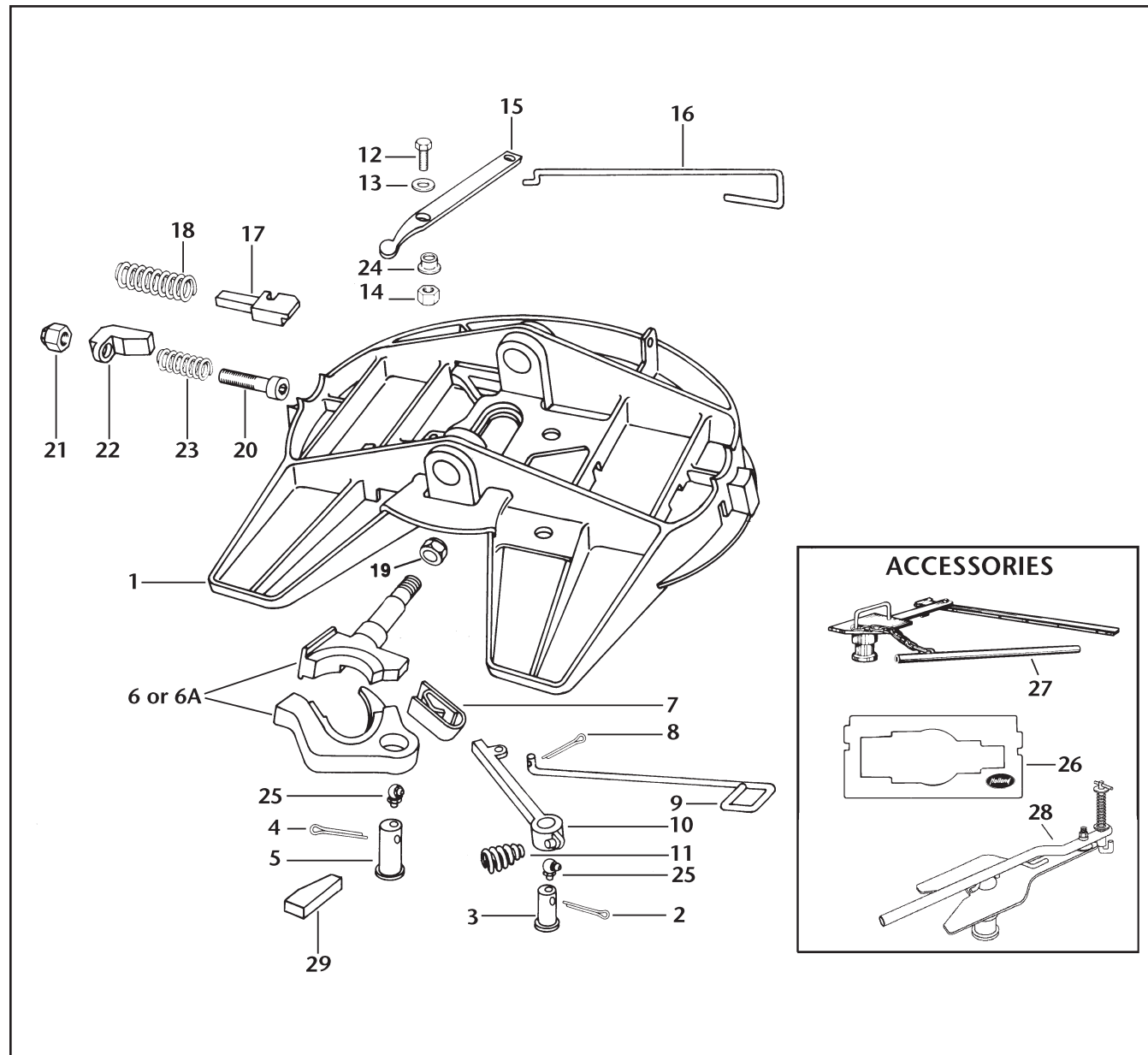

GENERAL INFORMATION

1. All fifth wheel maintenance, adjustment and rebuilding must be performed by a qualified person using proper tools and safe procedures. For more information, refer to HOLLAND publication FW-TE-14C, "Fifth Wheel Maintenance Procedures."
2. Do not modify or add to the product.
3. Use only genuine HOLLAND parts.
4. Wear safety goggles during installation, removal and rebuilding.
5. Never strike any part of the item with a steel hammer.
6. Do not weld on this product without written permission from the factory.
7. Observe standard precautions when lifting.
8. Refer to HOLLAND Publication FW 130 for description and instructions for Holland TF-TLN-5001 and TF-TLN-1500 Kingpin Lock Testers.
9. Do not deviate from these instructions. Any changes or deviations will void all warranties, expressed or implied, unless written consent is first obtained from the factory.
10. Check to see that all parts included in the kit are enclosed in the box.



These products are covered by HOLLAND'S Commercial Products Warranty. HOLLAND reserves the right, without giving prior notice, to change specifications and dimensions as designs are altered or improved.

ITEM	PART NO.	QTY.	PART NAME	ITEM	PART NO.	QTY.	PART NAME
1	XA-2081-D1	1	Fifth wheel top plate - 2" kingpin	15	XA-1005-FDS	1	Release lever
1A	XA-2081-03	1	Fifth wheel top plate - 3½" kingpin	16	XA-1117-13	1	Release handle
2	XB-5	1	Cotter pin 1/4" x 2"	17	XA-1104	1	Plunger
3	XA-1016-C	1	Lock pin	18	XB-1007	1	Compression spring (red)
4	XB-T-60	1	Cotter pin 1/4" x 2½"	19	XB-04473	1	Jam nut 1"-14
5	XA-FW-108-D	1	Lock pin	20	XB-2001	1	Socket head cap screw
6	XA-FW-104-D	1	Lock set for 2" kingpin	21	XB-HNH-58-C	1	Lock nut 5/8"-11
6A	XA-FW-104-03	1	Lock set for 3½" kingpin	22	XD-3123-1	1	Adjusting wedge
7	XA-FW-128	1	Spring	23	XB-403	1	Compression spring
8	XB-16	1	Cotter pin 1/8" x 1"	24	XB-02949	1	Bushing
9	XA-FW-138	1	Release handle	25	XB-0769	2	Lube fitting (90°)
10	XA-FW-137-2	1	Secondary lock arm	*26	TF-0110	1	Kingpin gage
11	XB-1028-2	1	Spring	*27	TF-TLN-1500	1	3½" kingpin lock tester
12	XB-2083	1	Hex head cap screw 1/2"-20x1¼"	*28	TF-TLN-5001	1	2" kingpin lock tester
13	XB-T-49	1	Plain washer	29	XA-05768	1	Adjusting block
14	XB-T-69-A	1	Hex lock nut 1/2"-20				

* Not included in Rebuild Kits

Uncoupling:

To uncouple the lock tester, pull the secondary lock release handle (9) out, raise it up and engage the handle lug with the top plate casting (Figure 12). Then, pull the release handle (16) out and raise it up and engage its handle lug with the top plate casting (Figure 13). This will retract the plunger (17) and hold it in so that the step in the plunger is not visible in the throat area. As the kingpin on the lock tester is pulled out (rearward), the swinging lock (6) will open. As the swinging lock opens, it will push the plunger back slightly, causing the release handle (16) to extend outward slightly. This action disengages the release handle from its notch in the casting, allowing the release handle to move to the locked position. As the swinging lock (6) opens past the plunger (17), the plunger will extend into the throat area and become visible again. The release handle (16) will move inward. As the swinging lock (6) opens fully, it will contact the retracted secondary lock (10), pushing the secondary lock release handle (9) slightly outward, causing its handle lug to disengage and allowing the handle to drop slightly.

WARNING: If the top plate assembly does not operate properly, **DO NOT USE IT.** Review the troubleshooting hints and rebuilding procedures or contact your local HOLLAND representative for assistance.

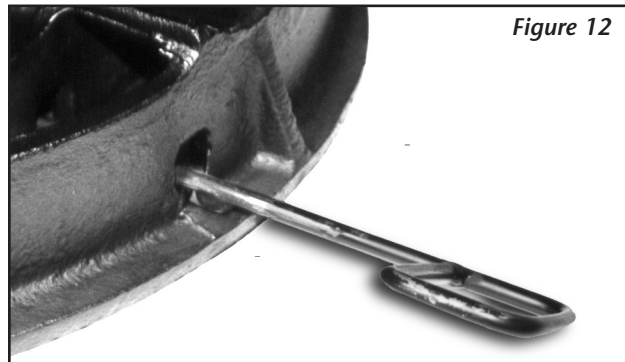

Figure 12

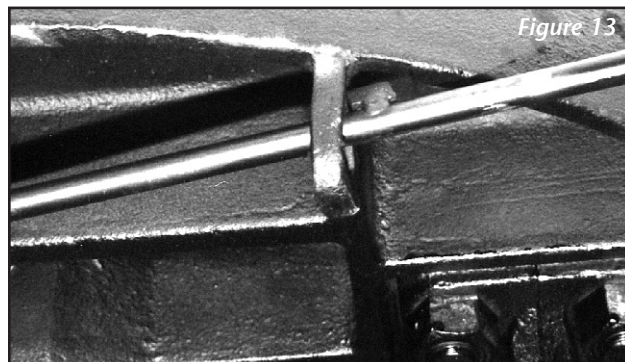

Figure 13

Check the Rocker Assembly and Brackets Before Remounting the Top Plate:

1. Inspect the rocker assembly and brackets for cracks or damage and replace if necessary.
2. Apply grease to the brackets and rocker assembly through the grease fittings located on the fifth wheel brackets and rocker assembly, as shown in Holland Publication "FW2080 Series Installation, Operation and Maintenance Instructions"; form number FW 246.

Periodic Maintenance and Adjustment:

1. Lubricate lock periodically by greasing through the fittings in the lock pins.
2. Lubricate the brackets and rocker by applying grease through the fittings provided.
3. For maximum service life, the fifth wheel should be steam cleaned, inspected and adjusted as necessary every 30,000 miles (50,000 km). For additional specific instructions, refer to HOLLAND publication FW-TE-14C "Fifth Wheel Maintenance Procedures."

Adjustment Procedure:

IMPORTANT: Adjustment must be performed with a lock tester having a kingpin to the SAE dimensions appropriate for your fifth wheel.

1. Close the locks using the lock tester.
2. Tighten the Allen head adjustment screw in the throat of the top plate by turning clockwise until tight.
3. Loosen the adjustment screw by turning counterclockwise 1½ turns. The fifth wheel is now properly adjusted.
4. Verify this adjustment by locking and unlocking several times.

REBUILDING PROCEDURES

1. Before attempting to rebuild, review each troubleshooting hint on the front page of this manual. You may find that rebuilding is not necessary.
2. If rebuilding is required, check the front page of this manual to be sure you have the correct kit for the fifth wheel you are about to rebuild.
3. Totally disassemble and clean the top plate.
4. Inspect the top plate for cracks and a loose lock pin hole. If the plate is cracked, or if the lock pin hole is elongated, the top plate must be discarded.

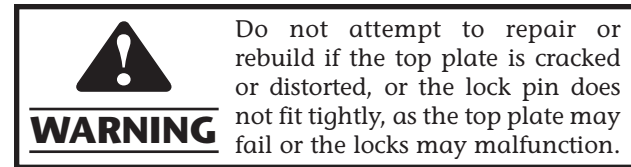

Do not attempt to repair or rebuild if the top plate is cracked or distorted, or the lock pin does not fit tightly, as the top plate may fail or the locks may malfunction.

NOTE: When rebuilding, use only HOLLAND rebuilding kits and replace all roll pins, cotter pins, springs, bolts, nuts and washers. Also, check the rebuild kit and verify that all parts are present.

Before starting to reassemble the fifth wheel, it may be necessary to fabricate a helper block. It can be made from hardwood or steel. Refer to Figure 1 for proper dimensions.

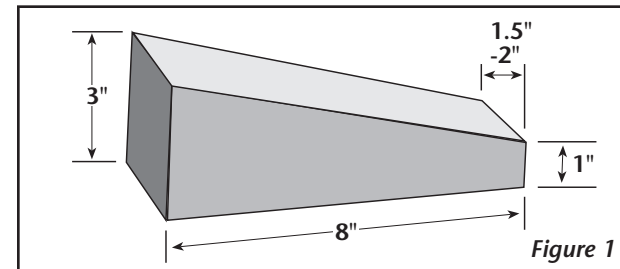

Figure 1

1. Install the adjusting screw (20) through the hole located in the throat of the fifth wheel casting. Install compression spring (23) over the screw, then slide the adjusting wedge (22) over the screw. Compress the spring and install lock nut (21). Tighten screw with 1/2" Allen wrench until nut is flush with the end of the bolt.
2. Lubricate the tail and faces of the plunger with a light grease. Install spring (18) over the tail of the plunger (17), insert through plunger slots in the casting. Use the helper block to hold the plunger (17) in place with the spring compressed.
3. Check the fit-up of the release lever (15) and plunger (17). The rounded end of the release

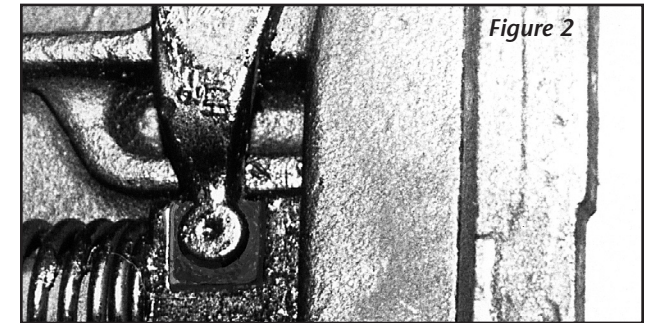

Figure 2

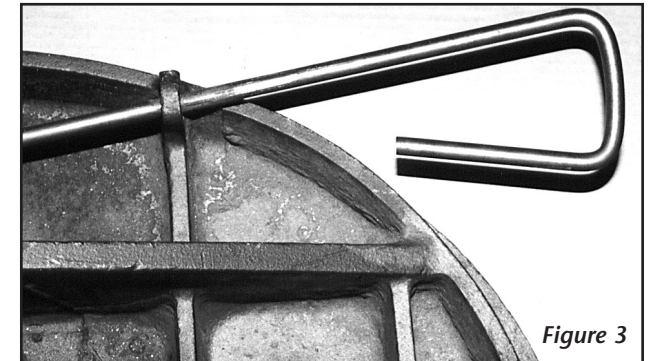

Figure 3

lever must fit freely into the slot in the plunger. If the parts do not fit together freely, it will be necessary to deburr the rounded end of the release lever (see Figure 2).

4. Install the release handle (16) through the guide slot in the casting. Install the release lever (15) on the handle (16). The open end of the release handle must face the rear of the casting, as shown in Figure 3.
5. Install nylon bushing (24) in the release lever (15) so that the flange is between the casting and lever. Install the release arm (15) in the slot on the plunger (see Figure 2), install washer (13) on cap screw (12) and insert through release lever (15) and screw into casting.

CAUTION: DO NOT OVERTIGHTEN as release arm (15) must move freely. Install hex head lock nut (14) on cap screw (12) and tighten.

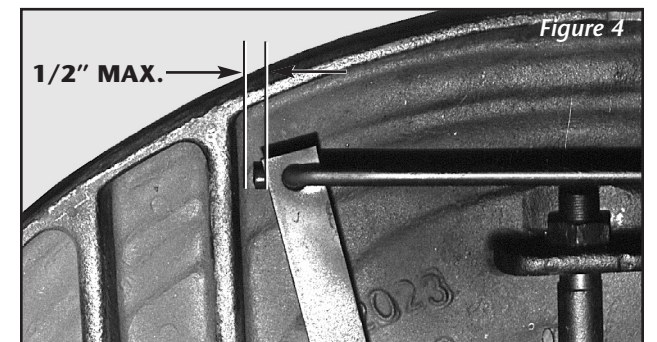
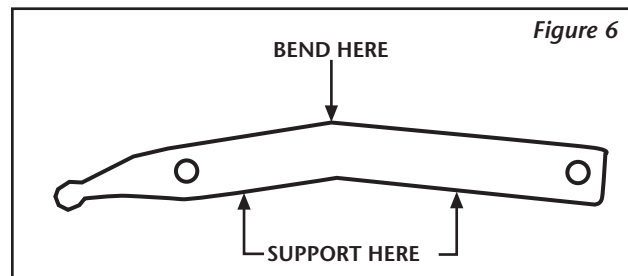
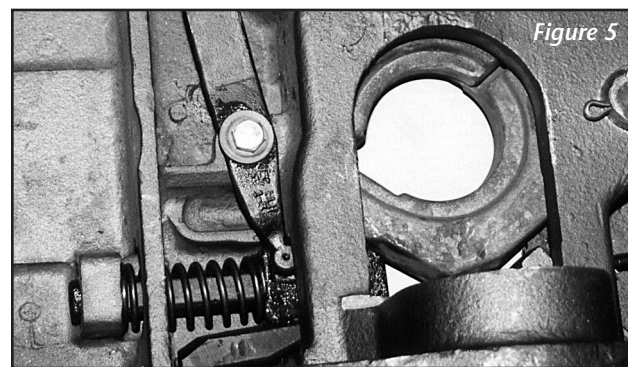
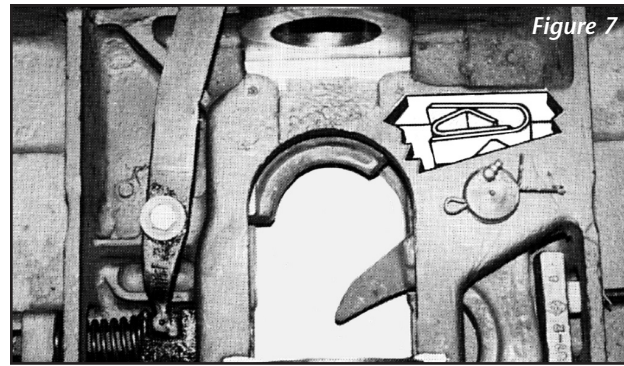

Figure 4

6. Check travel of the plunger. With the release handle in the closed position, the edge of the release lever (15) should be a maximum of 1/2" from the top plate casting rib (see Figure 4). If this condition does not exist, check if the rounded end of the release lever (15) is passing under the guide rib of the casting, as shown in Figure 5. If the rounded end is hitting the rib, bend the rounded end of the release lever (15) down so that it goes deeper into the plunger slot. If the release lever is still greater than 1/2" from the casting rib, remove the release lever and bend it as shown in Figure 6 until it is less than 1/2" from the casting. If the square end of the release lever (15) and/or end of the release handle (16) is hitting the casting rib (see Figure 4), grind the corner of the release lever (15) and/or the end of the handle (16) until it is clear of the casting rib.



7. Install the stationary lock (6) in the casting with the large counterbore facing down. Install the lock nut (19) onto the jaw and tighten until tight, but still allowing the lock to rotate slightly to ensure alignment with the kingpin.
8. Apply grease to spring (7) and install it into the casting. Position it as shown in Figure 7.
9. Coat the lock pin hole in the swinging lock (6) with Never-Seez® (supplied with kit). **This is VITAL. DO NOT USE** any substitute lubricant.
10. Before installing the swinging lock (6), you must place the secondary lock (10) into its approximate location in the casting (see Figure 9).
11. Place the swinging lock (6) into position compressing spring (7). **Note:** The lock pin



(5) has a hole for a grease fitting. Position the pin so that the hole faces the front of the casting. Drive the lock pin (5) through the holes in the casting and swinging lock and secure with cotter pin (4). Install the grease fitting so that it faces to the side and will be accessible from the left side of the tractor. (See Figure 8).

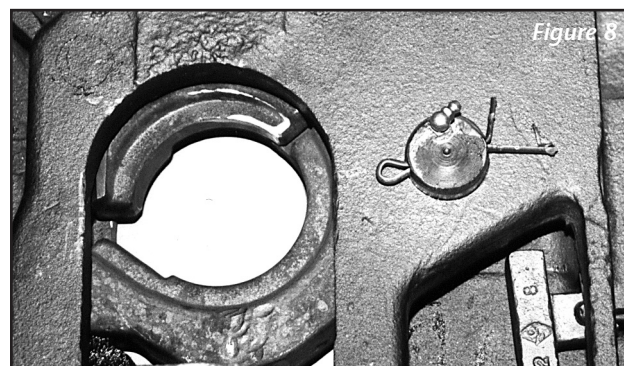

12. Turn the fifth wheel upright.

13. Check the Primary Lock Operation:

- A. Lock the fifth wheel using a Holland TF-TLN-5001 (2") lock tester or Holland TF-TLN-1500 (3 1/2") lock tester (as appropriate for the fifth wheel being rebuilt).
- B. Pull the primary release handle (16) out, raise it up and engage the handle lug with the top plate casting (see Figure 13).
- C. Pull the primary release handle (16) out further and install a small piece of 1/4" stock (not supplied) between the handle lug and the casting.
- D. Unlock the fifth wheel by removing the lock tester. When operating properly, this action will drop the 1/4" stock and the release handle will drop down and move to the locked position.
- E. If the 1/4" stock does not drop out, go back to Step 6 and bend the release arm (15) slightly in the opposite direction.
- F. Repeat Step D, above.

14. Secondary Lock Installation:

- A. Pre-install the secondary lock (10) in the closed position in the casting. Do not install the spring, release handle or the secondary lock pin yet. Align the secondary lock pin holes. Rotate the secondary lock until it makes contact with the casting at point (C) as shown in Figure 9. Check the rough location of the end of the secondary lock in relation to the swinging lock. It should be 3/16" (0.188") ± 1/16" (0.06") from point (A) on the swinging lock (see Figure 9) when secondary lock is resting against the casting at point (C).

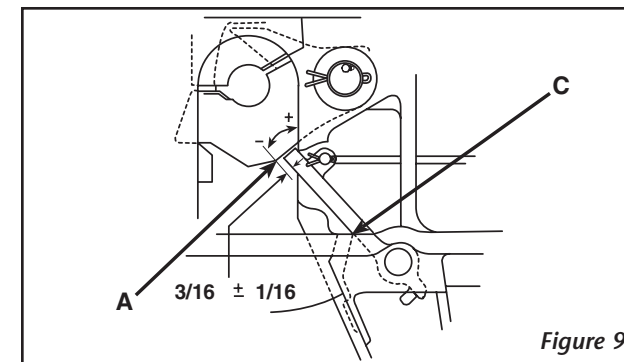

- B. If the dimension is less than 1/8" (0.125"), remove the secondary lock (10) and place a bead of weld on the fifth wheel casting at point (C) and grind smooth. If the dimension is greater than 1/4" (0.25"), remove the secondary lock and grind at point (D) as shown in Figure 10.

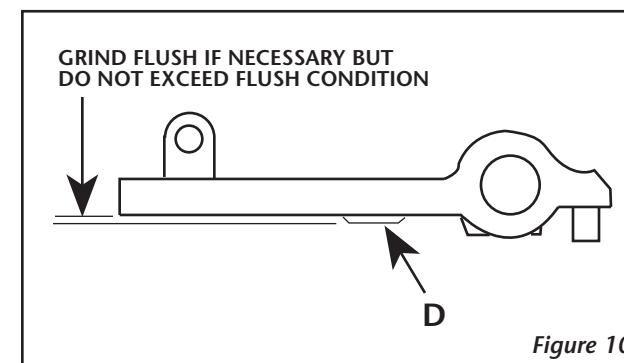

- C. After a final check of the dimensions, coat the lock pin hole in the secondary lock (10) with Never-Seez® (supplied with kit). **DO NOT** use any substitute lubricant.
- D. Install the secondary lock release handle (9) into the casting. Install the secondary lock (10) onto the handle. Install cotter pin (8) in handle and spread the cotter pin. Drive the secondary lock pin (3) through the holes in the casting and the secondary lock and secure with cotter pin (2). Install grease fitting (25) in lock pin

so that fitting faces the side and will be accessible from the left side of the tractor. Install spring (11) by fitting the small diameter end over the projection on the secondary lock (10) and the large diameter end into the spring pocket in the casting.

15. Adjust the Fifth Wheel Locks:

Leave lock tester in closed locks for this procedure: Using a ratchet with 1/2" Allen wrench, tighten the adjustment screw (20) in the throat in the fifth wheel by turning the screw clockwise until tight. Check that the kingpin on the lock tester is square to the swinging lock (6) and that the stationary lock is square to the kingpin. If not square, align the kingpin and/or stationary lock as necessary and retighten the adjusting screw. Tighten lock nut (19) on the stationary lock. Loosen the adjustment screw (20) by turning counterclockwise 1 1/2 turns. The locking mechanism is now properly adjusted.

16. Check that the secondary lock operates freely.
17. Check the operation of the fifth wheel by locking and unlocking several times.

Checking the Operation of the Fifth Wheel:

With the fifth wheel upright, it will function as follows: When the swinging lock (6) is open, the release handle (16) will be in; the plunger (17) will extend into the throat area such that the step in the plunger is visible in the throat, as shown in Figure 11, and the secondary lock release handle (18) will be out with the handle lug disengaged from the top plate casting.



Fifth Wheel Coupling:

As the lock tester is coupled to the fifth wheel, the swinging lock closes, pushing the plunger (17) back and the release handle (16) out.

As the swinging lock closes, the secondary lock spring will move the secondary lock into the closed position behind the swinging lock and move the release handle inward. When properly locked, the locking plunger (17) will be visible as shown in Figure 11.

IMPORTANT!

PROCEDURES FOR INSTALLATION OF SECONDARY LOCK ON MODELS **ORIGINALLY** EQUIPPED WITH SWINGING LOCK AND SECONDARY LOCK AS SHOWN IN **FIGURE A**, BELOW.

THESE INSTRUCTIONS REPLACE THE “**SECONDARY LOCK INSTALLATION**” SECTION IN THE ATTACHED MANUAL.

1. Coat the lock pin hole in the secondary lock (10) with Never-Seez® (supplied with kit). **DO NOT** use any substitute lubricant.
2. Install the secondary lock release handle (9) into the casting. Install the secondary lock (10) on to the handle. Install cotter pin (8) in handle and spread cotter pin. Drive the secondary lock pin (3) through the holes in the casting and secondary lock and secure with cotter pin (2). Install grease fitting (25) in the lock pin so that the fitting faces the side and will be accessible from the left side of the tractor.
3. Move the secondary lock handle to the closed position. Check the location of the end of the secondary lock in relation to the swinging lock. It should be $3/16'' (0.188'') \pm 1/16'' (0.06'')$ from point (A) on the swinging lock (see **Figure B**) when the secondary lock is resting against the casting at point (B).
4. If the secondary lock is not in the current position, install a secondary lock adjustment block (36) as shown in **Figure B**. Move the adjustment block until proper adjustment is achieved, then weld the adjustment block in position, as shown in **Figure B**. After welding, check the dimension and for proper operation of the secondary lock.

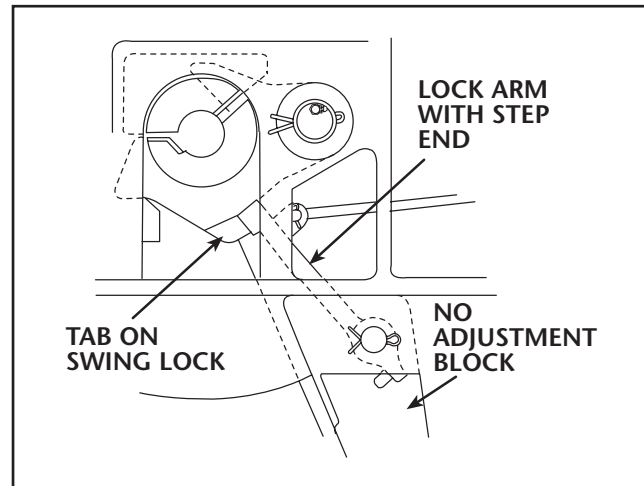

FIGURE A

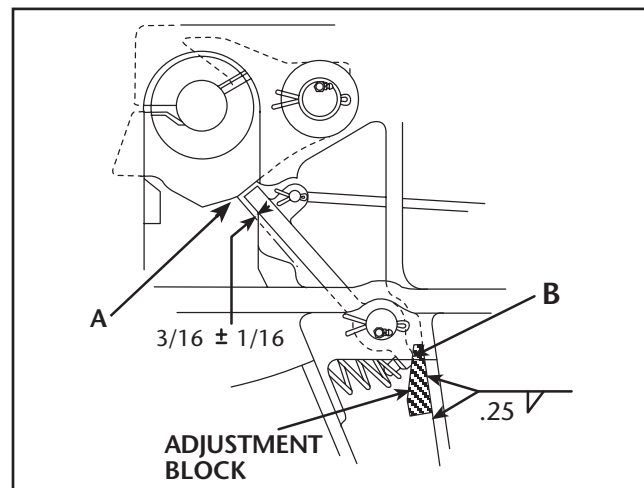

FIGURE B

IMPORTANT!

PROCEDURES FOR INSTALLATION OF SECONDARY LOCK ON MODELS **ALREADY** EQUIPPED WITH ADJUSTMENT BLOCK AS SHOWN IN **FIGURE C**, BELOW.

THESE INSTRUCTIONS REPLACE THE “**SECONDARY LOCK INSTALLATION**” SECTION IN THE ATTACHED MANUAL.

1. Pre-install the secondary lock (10) in the closed position in the casting. Do not install spring, handle, or secondary lock pin yet. Align the lock pin holes and rotate the secondary lock up against the adjustment block. Check the location of the end of the secondary lock in relation to the swinging lock. It should be $3/16'' (0.188'') \pm 1/16'' (0.06'')$ from point (A) on the swinging lock (see **Figure D**) when the secondary lock is resting against the adjusting block at point (B).

A. If the dimension is less than 1/8" (0.125"):

Mark the area where the secondary lock made contact with the adjusting block. Remove the secondary lock, then place a bead of weld on the adjusting block where the secondary lock makes contact with the adjusting block and grind smooth. Do not weld on the secondary lock. After welding, recheck as in **Step 1**, above.

B. If the dimension is more than 1/4" (0.25"):

Mark the area where the secondary lock makes contact with the adjusting block. Remove the secondary lock, then grind on the adjusting block. **CAUTION:** A small amount of grinding on the adjusting block results in a large movement of the secondary lock. After grinding, recheck, as in **Step 1**.

- C.** After a final check of the dimension, coat the lock pin hole in the secondary lock (10) with Never-Seez® (supplied with kit). **DO NOT** use any substitute lubricant.

- D.** Install the secondary lock release handle (9) into the casting. Install the secondary lock (10) onto the handle. Install cotter pin (8) in handle and spread cotter pin. Drive the secondary lock pin (3) through the holes in the casting and the secondary lock and secure with cotter pin (2). Install grease fitting (25) in lock pin so that the fitting faces the side and will be accessible from the left side of the tractor.

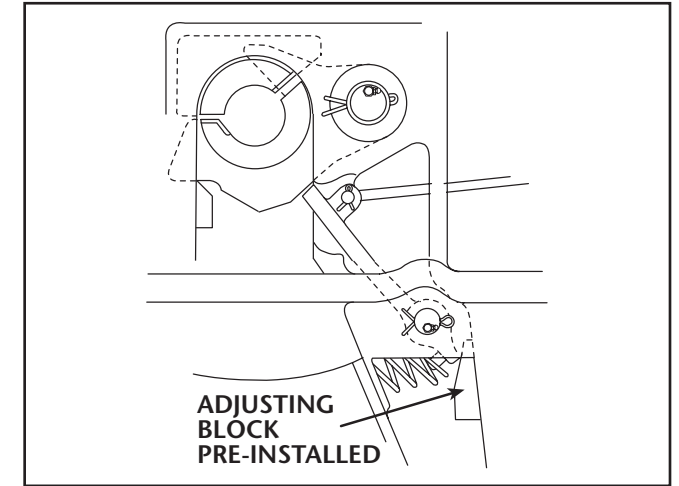

FIGURE C

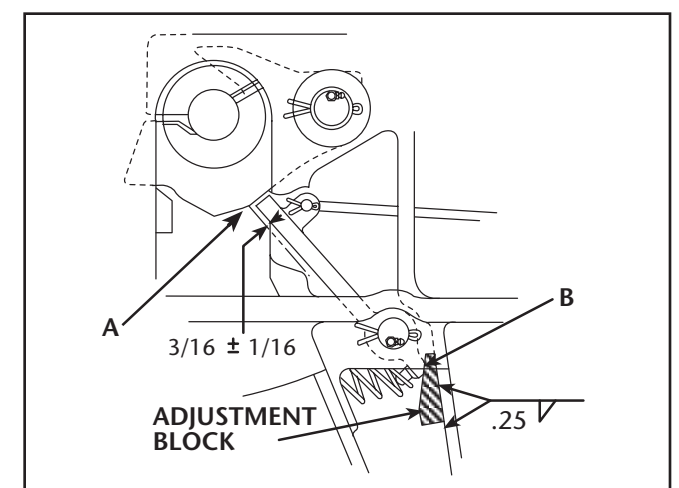

FIGURE D