



FIFTH WHEELS

TROUBLESHOOTING AND REBUILD PROCEDURES



XA-71 Series Fifth Wheel Top Plates

XA-71-DA
2" SAE Kingpin (Rebuild Kit RK-65014)

XA-71-DA-03705
2" SAE Kingpin for FW2570-7103 SERIES or
FW2570-7113 SERIES - RK-65014-1

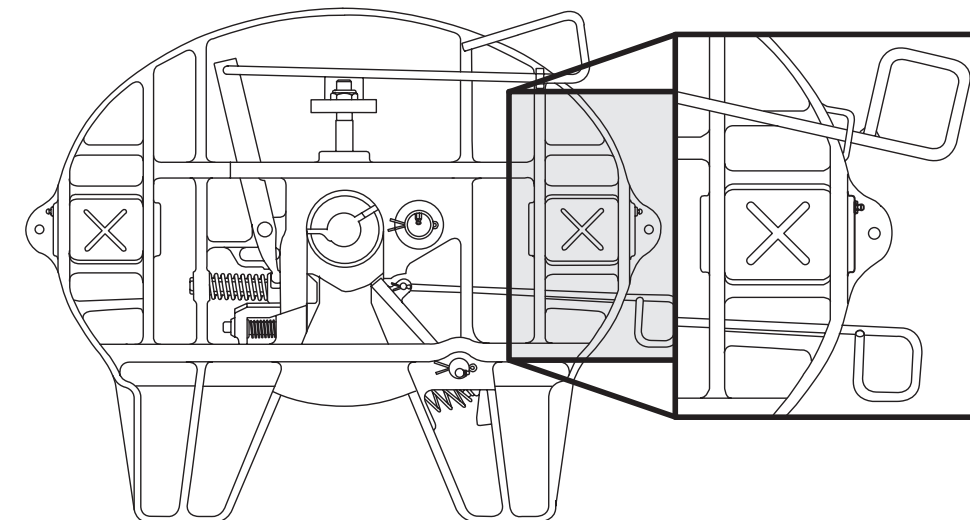

XA-71-OA
3½" SAE Kingpin (Rebuild Kit RK-65015)

XA-71-OA-03713
3½" SAE Kingpin for FW2570-7103 SERIES or
FW2570-7113 SERIES - RK-65015-1

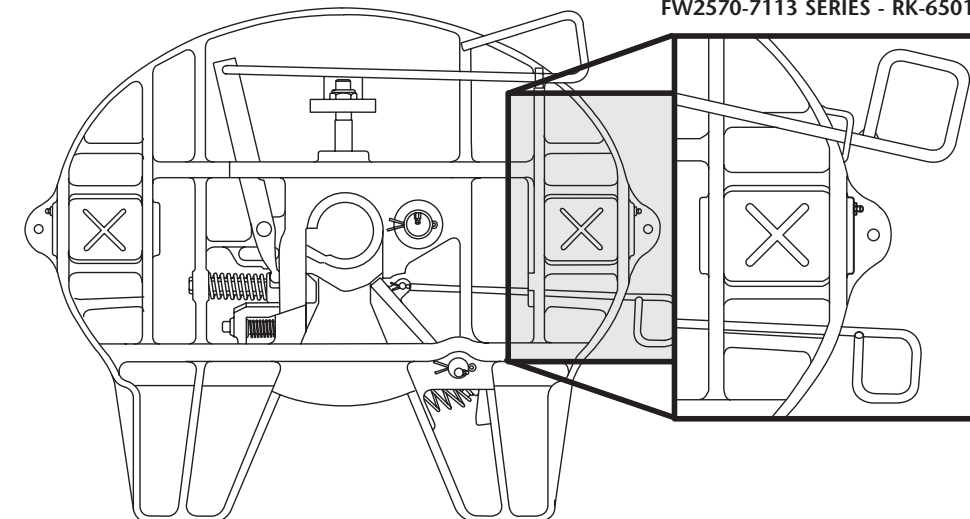

GO THE DISTANCE.

HOLLAND USA, INC.
1950 Industrial Blvd. • P.O. Box 425 • Muskegon, MI 49443-0425
Phone 888-396-6501 • Fax 800-356-3929
www.thehollandgroupinc.com

Copyright © August 2002 • The Holland Group, Inc.

Holland USA, Inc. Facilities:

Denmark, SC Muskegon, MI
Dumas, AR Warrenton, MO
Holland, MI Whitehouse Station, NJ
Milpitas, CA Wylie, TX

Ph: 888-396-6501 Fax: 800-356-3929

Holland International, Inc.

Holland, MI
Phone: 616-396-6501
Fax: 616-396-1511

Holland Hitch of Canada, Ltd.

Woodstock, Ontario • Canada
Phone: 519-537-3494
Fax: 800-565-7753

Holland Equipment, Ltd.

Norwich, Ontario • Canada
Phone: 519-863-3414
Fax: 519-863-2398

Holland Hitch Western, Ltd.

Surrey, British Columbia • Canada
Phone: 604-574-7491
Fax: 604-574-0244

TROUBLESHOOTING HINTS

Fifth Wheel is Hard to Hook Up to Trailer:

✓	POSSIBLE CAUSE	REMEDY
<input type="checkbox"/>	The trailer may be too high; the kingpin is not entering the locks properly.	Lower the trailer landing gear.
<input type="checkbox"/>	Locks are closed.	Pull the secondary and primary release handles to the unlocked position and force the hinged lock open.
<input type="checkbox"/>	The locks are adjusted too tightly.	Check lock adjustments in accordance with the procedure in this manual.
<input type="checkbox"/>	Accumulated rust or grime interfering with the lock operation.	Spray a light lubricant or diesel fuel on all moving parts, including the release handle, and operate several times.
<input type="checkbox"/>	Bent release handle or kingpin or damaged bolster plate may be interfering with lock movement.	Check and repair/replace as required. The kingpin can be inspected in accordance with SAE J2228.
<input type="checkbox"/>	The locks may be damaged.	Inspect and replace, if required, following the procedures in this manual.
<input type="checkbox"/>	The fifth wheel may need rebuilding.	Follow the procedures contained in this manual using the appropriate rebuilding kit.
<input type="checkbox"/>	Using lube plate with wrong kingpin length.	See Holland Service Bulletin XL-SB004.

Fifth Wheel is Hard to Unhook from Trailer:

✓	POSSIBLE CAUSE	REMEDY
<input type="checkbox"/>	The secondary lock is not released.	Pull the secondary lock release handle and lift up to engage the handle lug with the top plate casting.
<input type="checkbox"/>	The tractor may be putting pressure against locks.	Back the tractor into the trailer to relieve the pressure and lock the tractor brakes before pulling the release handle.
<input type="checkbox"/>	Rust or grime on the locking mechanism.	Spray a light lubricant or diesel fuel on all moving parts, including the release handle, and operate several times.
<input type="checkbox"/>	Bent kingpin or damaged bolster plate.	Check the kingpin with a Holland TF-0110 Kingpin Gage and bolster plate with a 48" straightedge. Repair/replace as required. The kingpin can be inspected in accordance with SAE J2228.
<input type="checkbox"/>	Fifth wheel locks may be adjusted too tightly.	Check the lock adjustment in accordance with procedures in this manual.
<input type="checkbox"/>	The release handle will not stay out.	Pull the release handle out and up, then release.
<input type="checkbox"/>	The release handle will not stay out; pops off lug.	Replace release handle.
<input type="checkbox"/>	The release handle must be held out.	Build up release handle lug to hold out further or replace XA-1005-FH, XA-1117-H or XA-03715 release handles.
<input type="checkbox"/>	Long plunger.	Pull the release handle to the fully extended position and hold it while someone else attempts to uncouple. If the locks do not open under this condition, close the swinging lock partially and grind 1/16" of the tip of the swinging lock. Round off after grinding.
<input type="checkbox"/>	Using lube plate with wrong kingpin length.	See Holland Service Bulletin XL-SB004.

NOTE: After the fifth wheel is unlocked and moves freely from the kingpin, it is normal for the release handle to return to the "in" position.

ALTERNATIVE "SECONDARY LOCK INSTALLATION"

For fifth wheel models **ORIGINALLY** equipped with a tab on the swing lock and a step end on the lock arm, follow the instructions below and refer to **FIGURE A**, at right.

1. Coat the lock pin hole in the secondary lock (10) with Never-Seez® (supplied with kit). **DO NOT** use a substitute lubricant.
2. Install the secondary lock release handle (9) into the casting. Install the secondary lock onto the handle. Install a cotter pin (8) in the handle and spread it. Drive the secondary lock pin (3) through the holes in the casting and secondary lock, and secure with a cotter pin (2). Install a grease fitting (25) in the lock pin so that the fitting faces the side, and will be accessible from the left side of the tractor.
3. Move the secondary lock handle to the closed position. Check the location of the end of the secondary lock in relation to the swinging lock. It should be $3/16"$ (0.188") $\pm 1/16"$ (0.06") from point A on the swinging lock (see **FIGURE B**) when the secondary lock is resting against the casting at point B.
4. If the secondary lock is not in the current position, install a secondary lock adjustment block (36) as shown in **FIGURE B**. Move the adjustment block until proper adjustment is achieved, then weld the adjustment block in position, as shown in **FIGURE B**. After welding, check the dimension and for proper operation of the secondary lock.

FIGURE A

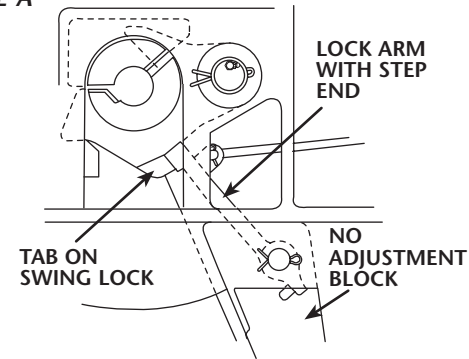

FIGURE B

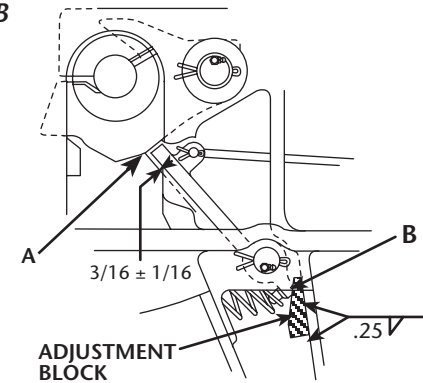

FIGURE C

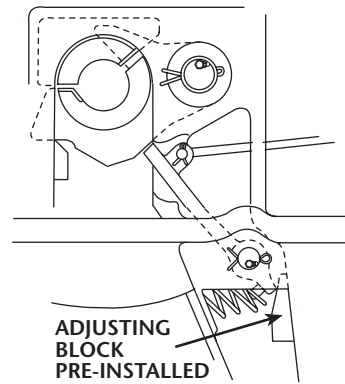
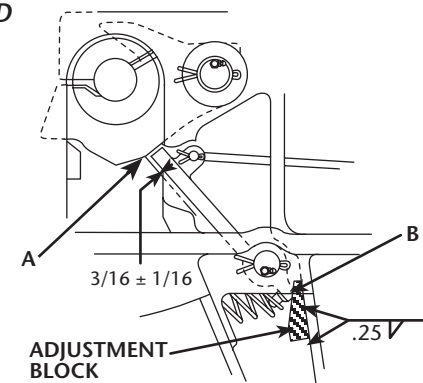

FIGURE D



For fifth wheel models **ALREADY** equipped with an adjustment block, follow the instructions below and refer to **FIGURE C**, at right.

1. Pre-install the secondary lock (10) in the closed position in the casting. Complete **Steps 1, 2, and 3** before installing the spring, release handle, and the secondary lock pin. Align the lock pin holes and rotate the secondary lock up against the adjustment block. Check the location of the end of the secondary lock in relation to the swinging lock. It should be $3/16"$ (0.188") $\pm 1/16"$ (0.06") from point A on the swinging lock (see **FIGURE D**) when the secondary lock is resting against the adjusting block at point B.
2. **If the dimension is less than $1/8"$ (0.125"),** mark the area where the secondary lock made contact with the adjusting block. Remove the secondary lock, then place a bead of weld on the adjusting block, where the secondary lock makes contact with the adjusting block, and grind smooth. Do not weld on the secondary lock. After welding, re-check as in **STEP 1**, in this section.
3. **If the dimension is more than $1/4"$ (0.25"),** mark the area where the secondary lock makes contact with the adjusting block. Remove the secondary lock, then grind on the adjusting block. **CAUTION:** A small amount of grinding on the adjusting block results in a large movement of the secondary lock. After grinding, re-check, as in **STEP 1**, in this section.
- C. After a final check of the dimension, coat the lock pin hole in the secondary lock (10) with Never-Seez® (supplied with kit). **DO NOT** use a substitute lubricant.
- D. Install the secondary lock release handle (9) into the casting. Install the secondary lock (10) onto the handle. Install a cotter pin (8) in the handle and spread it. Drive the secondary lock pin (3) through the holes in the casting and the secondary lock, and secure with a cotter pin (2). Install a grease fitting (25) in lock pin so that the fitting faces the side and will be accessible from the left side of the tractor.

XA-71 SERIES PARTS EXPLOSION

Part numbers indicated throughout the instructions in bold numbers—for instance "fifth wheel top plate (1)"—refer back to this drawing.

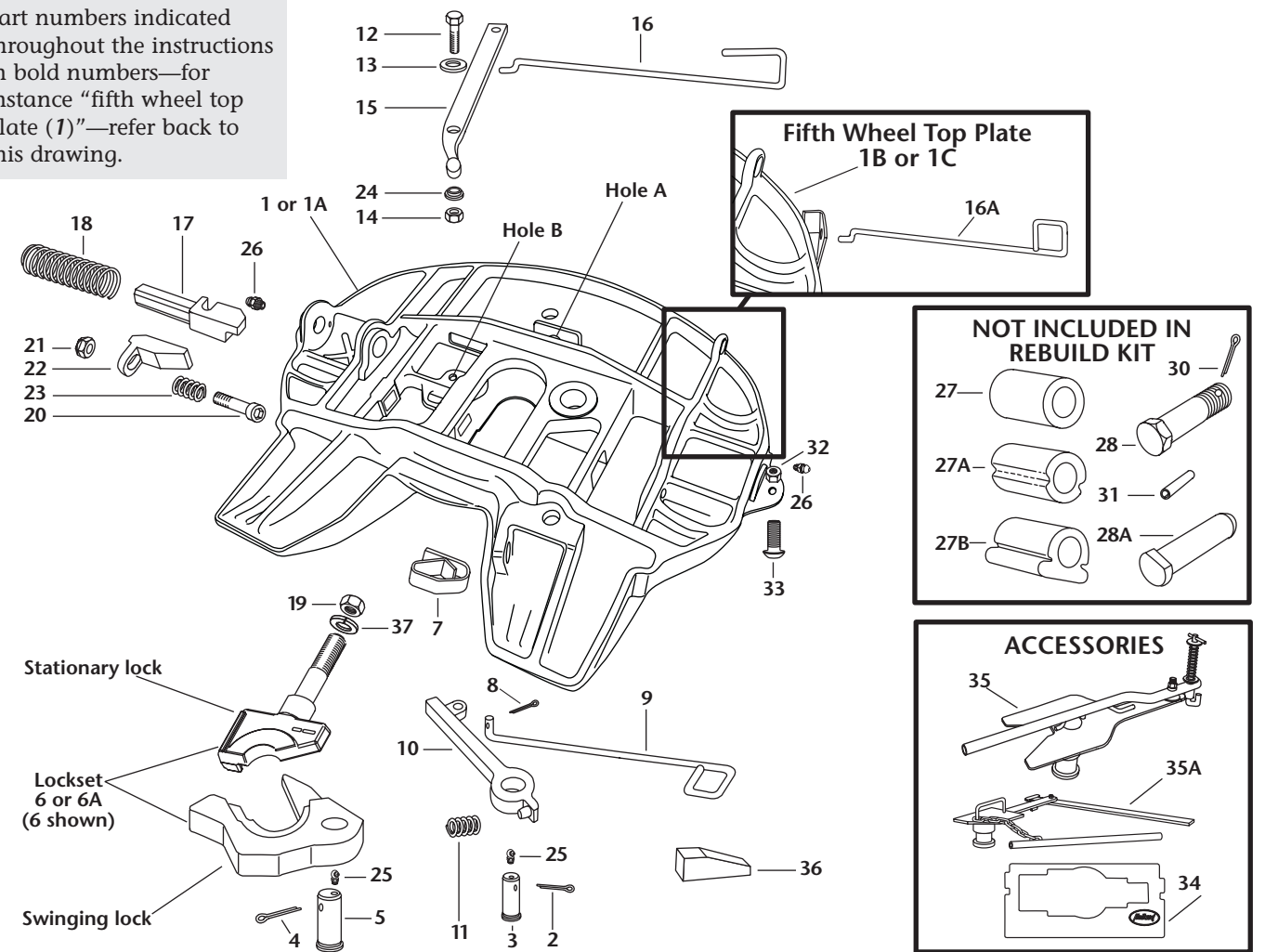

ITEM	PART NO.	NO.	PART NAME	ITEM	PART NO.	NO.	PART NAME
1	XA-71-D	1	Fifth wheel top plate for 2" kingpin	17	XA-1104	1	Plunger
1A	XA-71-O	1	Fifth wheel top plate for 3.5" kingpin	18	XB-1007	1	Compression spring (red)
1B	XA-71-03706	1	Fifth wheel top plate - 2" kingpin for FW2570-7103 series or FW2570-7113 series only	19	XB-04473	1	Jam nut 1" - 14
1C	XA-03711	1	Fifth whl. top plate - 3.5" kingpin for FW2570-7103 or FW2570-7113 series only	20	XB-09407	1	Socket head cap screw
2	XB-5	1	Cotter pin 1/4" x 2"	21	XB-HNH-58-C	1	Lock nut 5/8" - 11
3	XA-1016-C	1	Lock pin	22	XD-3123-1	1	Adjusting wedge
4	XB-T-60	1	Cotter pin 1/4" x 2.5"	23	XB-403	1	Compression spring
5	XA-FW-108-D	1	Lock pin	24	XB-02949	1	Nylon bushing
6	XA-FW-104-D	1	Lock set for 2" kingpin	25	XB-0769	2	Lube fitting (90°)
6A	XA-FW-104-03	1	Lock set for 3.5" kingpin	26	XB-H-38	2	Lube fitting
7	XA-FW-128	1	Spring	* 27	XB-1604-9	2	Bushing (prior to 5/82)
8	XB-16	1	Cotter pin 1/8" x 1"	* 27A	XB-0012-1	2	Bushing (5/82 - 9/87)
9	XA-FW-78	1	Secondary lock release handle	* 27B	XB-0012-3	2	Bushing (after 9/87)
10	XA-FW-137-2	1	Secondary lock arm	* 28	XA-2632	2	Pivot bolt (prior to 11/86)
11	XB-1028-2	1	Spring	* 28A	XE-02759	2	Pivot pin (after 11/86)
12	XB-2083	1	Hex hd. bolt 1/2" - 20 x 1.75"	* 29	XB-T-9N-2	2	Nut (prior to 11/86) (not shown)
13	XB-T-49	1	Plain washer	* 30	XB-T-60	2	Cotter pin (prior to 11/86)
14	XB-T-69-A	1	Hex lock nut	* 31	XB-21-S-375-1750	2	Roll pin
15	XA-1005-FH	1	Release lever	* 32	XB-T-69-A	2	Hex lock nut
16	XA-1117-H	1	Release handle	* 33	XB-08002	2	Socket button head cap screw
16A	XA-03715	1	Release handle	* 34	TF-0110	1	Kingpin gage
				* 35	TF-TLN-5001	1	2" kingpin lock tester
				* 35A	TF-TLN-1500	1	3.5" kingpin lock tester
				36	XA-05768-1	1	Adjusting block
				37	XB-10327	1	Lock washer, 1"

* Not included in Rebuild Kits

REBUILDING PROCEDURES

1. Before attempting to rebuild, review each troubleshooting hint on page 2 of this manual. You may find that rebuilding is not necessary.
2. If rebuilding is required, check the front page of this manual to be sure you have the correct kit for the fifth wheel you are about to rebuild.
3. Totally disassemble and clean the top plate.
4. Inspect the top plate for cracks and a loose lock pin hole. If the plate is cracked, or if the lock pin hole is elongated, the top plate must be discarded.

⚠ WARNING Do not attempt to repair or rebuild if the top plate is cracked or distorted, or the lock pin does not fit tightly, as the top plate may fail or the locks may malfunction. Failure to properly install, operate, or maintain this fifth wheel could result in tractor and trailer separation causing death or serious injury to others.

NOTE: When rebuilding, use only Holland rebuilding kits and replace all roll pins, cotter pins, springs, bolts, nuts, and washers. Also, check the rebuild kit and verify that all parts are present (refer to page 3).

Fifth Wheel Reassembly

Before starting to reassemble the fifth wheel, it will be helpful to fabricate a helper block. It can be made from hardwood or steel. Refer to **FIGURE 1** for proper dimensions.

FIGURE 1

XA-71-DA

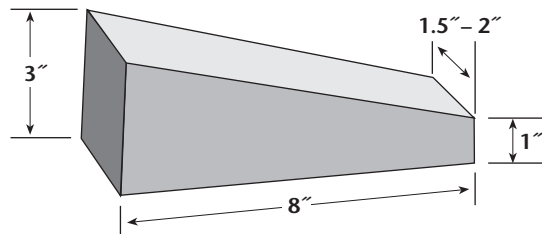

XA-71-OA

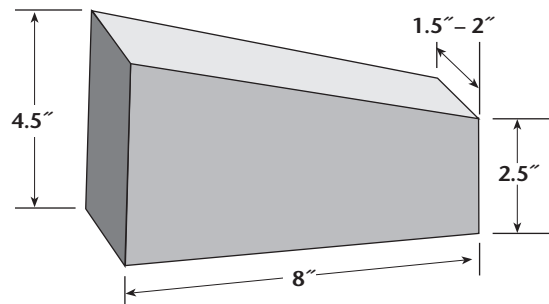

Primary Lock Installation

1. Install the stationary lock (6) in **HOLE A** in the casting, with the large counterbore facing down (see **FIGURE 2**). Install the lock washer (37) and lock nut (19) onto the threaded end of the stationary lock. Tighten until tight, but still allow the lock to rotate slightly, in order to ensure alignment with the kingpin. The lock nut will be tightened fully when adjusting the fifth wheel locks later in this procedure.

FIGURE 2

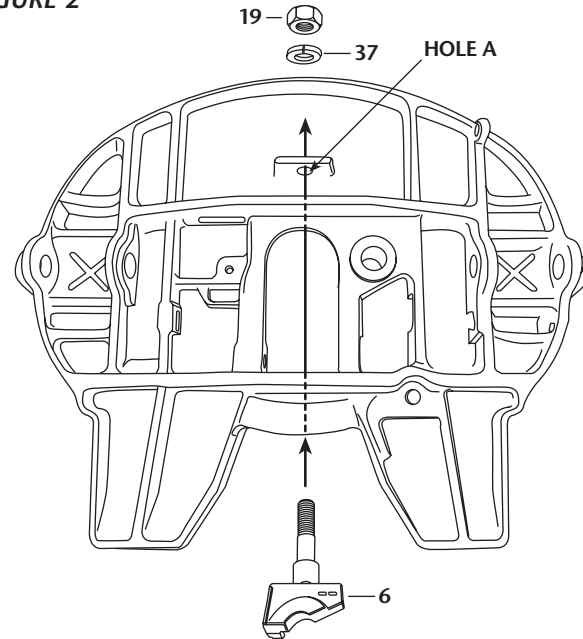

2. Apply grease to the spring (7) and install it into the casting. Position it as shown in **FIGURE 3**.

FIGURE 3

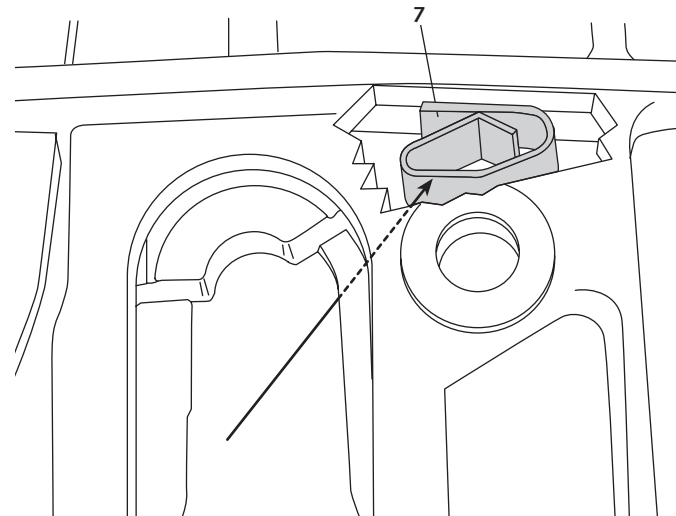

continued

CHECKING THE OPERATION OF THE FIFTH WHEEL *continued*

Check the Mounting Brackets Before Remounting the Top Plate:

1. Inspect the brackets for cracks or damage, and replace if necessary.
2. Check the rubber bushings for wear. Replace if necessary.
3. Apply grease to the top bearing surface of the mounting bracket before remounting the top plate.
4. Inspect the bracket pins (or bolts, depending on the construction of your fifth wheel) for wear. Replace, if necessary, using the same configuration as was removed when the fifth wheel was disassembled.

Periodic Maintenance and Adjustment:

1. Lubricate the lock periodically by greasing through the fittings in the lock pins.
2. Lubricate the top plate and brackets by greasing through the two fittings on the sides of the fifth wheel.

3. For maximum service life, the fifth wheel should be steam cleaned, inspected, and adjusted — as necessary — every 30,000 miles (50,000 km).

For additional specific instructions, refer to HOLLAND publication XL-FW303-XX "Fifth Wheel Maintenance Procedures."

Adjustment Procedure:

IMPORTANT: Adjustment must be performed with a lock tester — using a kingpin with SAE approved dimensions — appropriate for your fifth wheel.

1. Close the locks using the lock tester.
2. Tighten the Allen head adjustment screw in the throat of the top plate by turning clockwise until tight.
3. Loosen the adjustment screw by turning counterclockwise 1½ turns. The fifth wheel is now properly adjusted.
4. Verify this adjustment by locking and unlocking several times.

GENERAL INFORMATION

1. All fifth wheel maintenance, adjustment and rebuilding must be performed by a qualified person using proper tools and safe procedures. For more information, refer to HOLLAND publication XL-FW303, "Fifth Wheel Maintenance Procedures."
2. Do not modify or add to the product.
3. Use only genuine HOLLAND parts.
4. Wear safety goggles during installation, removal and rebuilding.
5. Never strike any part of the item with a steel hammer.
6. Do not weld on this product without written permission from the factory.

7. Observe standard precautions when lifting.
8. Do not deviate from these instructions. Any changes or deviations will void all warranties, expressed or implied, unless written consent is first obtained from the factory.
9. Check to see that all parts included in the kit are enclosed in the box.
10. This equipment must not be used or maintained in a careless manner.

These products are covered by HOLLAND'S Commercial Products Warranty. HOLLAND reserves the right, without giving prior notice, to change specifications and dimensions as designs are altered or improved.

Release Arm and Release Lever Installation

1. Check the fit of the release lever (15) inside the slot in the plunger (17). The rounded end of the release lever must fit freely into the slot in the plunger. If the parts do not fit together freely, it will be necessary to deburr the rounded end of the release lever (see FIGURE 9). Once you have checked the fit, remove the release lever in order to attach it to the release arm in the following step.

FIGURE 9

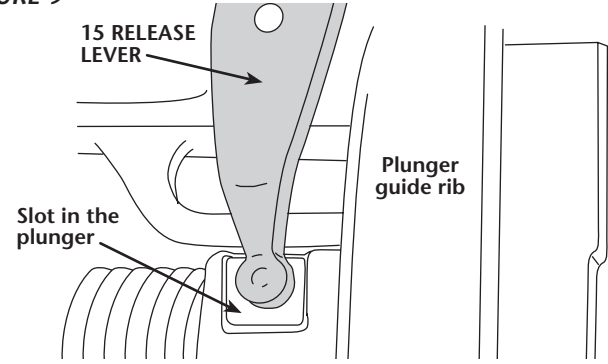

2. Install the release handle (16) through the guide slot in the casting. Install the end of the release handle (16) into the hole in the end of the release lever (15). The open end of the release handle must face the front of the casting, as shown in FIGURE 10. Guide the round end of the release lever through the guide rib in the casting.

FIGURE 10

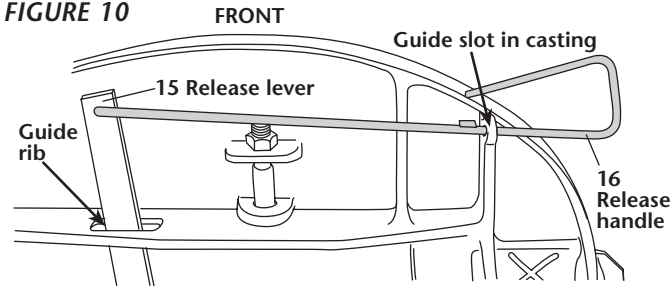

3. Install the nylon bushing (24) into the release lever (15) so that the flange is between the casting and the lever (see FIGURE 11).

FIGURE 11

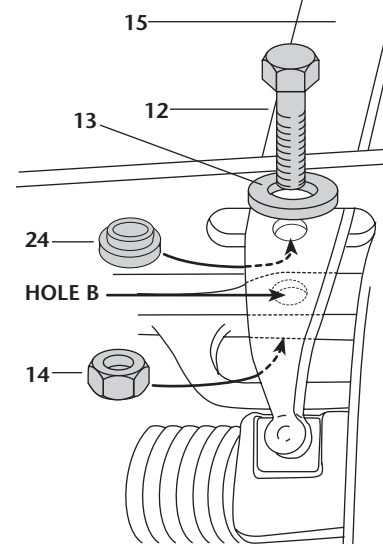

Install the release lever into the slot on the plunger. Install the washer (13) onto the cap screw (12) and insert them through the release lever (15) and through HOLE B in the casting.

4. Install hex lock nut (14) and tighten.

⚠ WARNING DO NOT OVERTIGHTEN as the release lever (15) must move freely. If it does not move freely, the fifth wheel may not couple properly or completely and could result in tractor/trailer separation causing death or serious injury.

5. Remove the helper block. Check the travel of the plunger. With the release handle in the closed position, the edge of the release lever (15) should be a maximum of 1/2" from the top plate casting rib (see FIGURE 12).

FIGURE 12

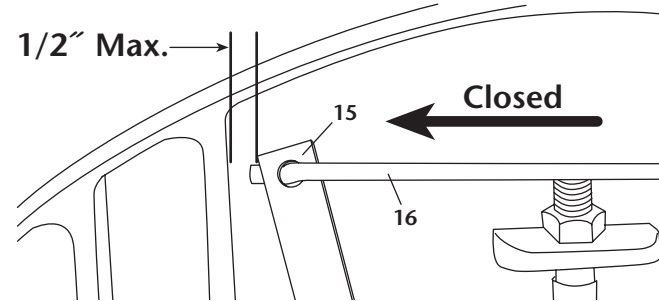

If this condition does not exist, check that the rounded end of the release lever (15) is not hitting the plunger guide rib of the casting, see FIGURE 9. If the rounded end is hitting the rib, bend the rounded end of the release lever down so that it goes deeper into the plunger slot. If the release lever is still greater than 1/2" from the casting rib, remove the release lever and bend it (as shown in FIGURE 13) until it is less than 1/2" from the casting. If the square end of the release lever — and/or the end of the release handle (16) — is hitting the casting rib, grind the corner of the release lever (15) — and/or the end of the handle (16) — until it is 1/2" clear of the casting rib.

FIGURE 13

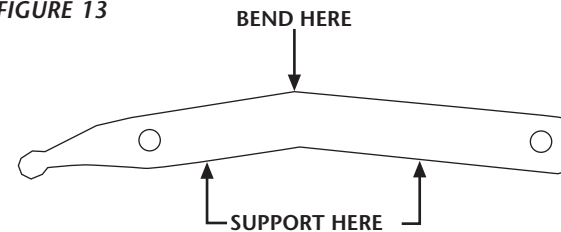

Swinging Lock Installation

1. Place the swinging lock (6) into position, compressing spring (7). For spring position, see FIGURE 3.

NOTE: The lock pin (5) has a hole for a grease fitting (25).

Position the pin so that the hole faces the front of the casting. Drive the lock pin (5) through the holes in the casting and swinging lock and secure with a cotter pin (4). Install the grease fitting so that it faces to the side and will be accessible from the left side of the tractor. (See FIGURE 14).

FIGURE 14

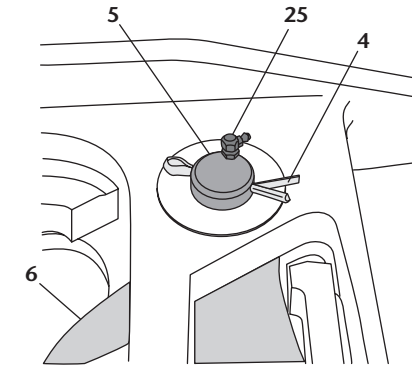

2. Turn the fifth wheel upright.

Check the Primary Lock Operation:

1. Lock the fifth wheel using a Holland TF-TLN-5001 (2") lock tester (35) or a Holland TF-TLN-1500 (3 1/2") lock tester (35A) (as appropriate for the fifth wheel being rebuilt). Refer to HOLLAND Publication XL-FW340 for description and instructions for Holland TF-TLN-5001 Lock Adjustment Tool and, Publication XL-FW130 for Holland TF-TLN-1500 Kingpin Lock Tester.
2. Pull the primary release handle (16) out, raise it up and engage the handle lug with the top plate casting (see FIGURE 15).

FIGURE 15

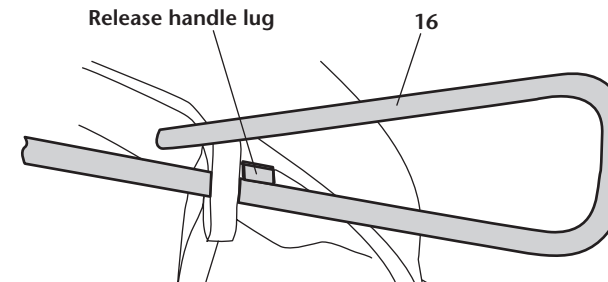

3. Pull the primary release handle (16) out further and install a small piece of 1/4" stock (not supplied) between the handle lug and the casting.
4. Unlock the fifth wheel by removing the lock tester. When operating properly, this action will drop the 1/4" stock and the release handle will drop down and move to the locked position.
5. If the 1/4" stock does not drop out, go back to STEP 5 on page 6 and bend the release lever (15) slightly in the opposite direction.
6. Repeat STEP 4, above.
7. Turn the fifth wheel back over.

IMPORTANT: Before proceeding with Secondary Lock Installation, turn to page 10 to determine which instructions you should follow.

Secondary Lock Installation:

1. Position the secondary lock (10) in the closed position in the casting, as shown in FIGURE 16. Complete Steps 1, 2, and 3 before installing the spring, release handle, and the secondary lock pin. Align the secondary lock pin holes. Rotate the secondary lock until it makes contact with the casting at point C as shown in FIGURE 16. Check the rough location of the end of the secondary lock in relation to the swinging lock. It should be 3/16" (0.188") ± 1/16" (0.06") from point A on the swinging lock (see FIGURE 16) when the secondary lock is resting against the casting at point C.

FIGURE 16

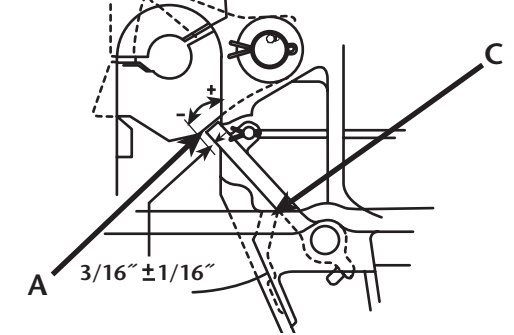

2. If the dimension is less than 1/8" (0.125"), remove the secondary lock (10) and place a bead of weld on the fifth wheel casting at point C and grind smooth. If the dimension is greater than 1/4" (0.25"), remove the secondary lock and grind at point D as shown in FIGURE 17.

FIGURE 17

Grind flush if necessary but do not exceed flush condition.

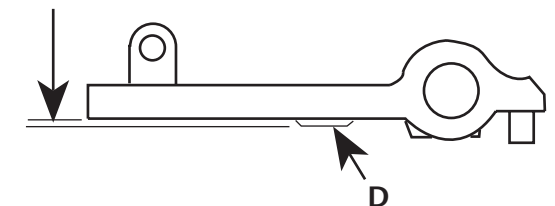

3. After a final check of the dimensions, coat the lock pin hole in the secondary lock (10) with Never-Seez® (supplied with kit). **DO NOT** use a substitute lubricant.
4. Install the secondary lock release handle (9) into the casting. Install the secondary lock (10) onto the handle. Install the cotter pin (8) in the handle and spread it. Drive the secondary lock pin (3) through the holes in the casting and the secondary lock, and secure with a cotter pin (2). Install a grease fitting (25) in the lock pin so that the fitting faces the side, and will be accessible from the left side of the tractor. Install spring (11) by fitting the small diameter end over the projection on the secondary lock (10) and the large diameter end into the spring pocket in the casting.

Adjust the Fifth Wheel Locks:

1. Using a ratchet with 1/2" Allen wrench, tighten the adjustment screw (20) in the throat in the fifth wheel, by turning the screw clockwise until tight.
2. Check that the kingpin on the lock tester is square to the swinging lock (6) and that the stationary lock is square to the kingpin. If not square, align the kingpin and/or stationary lock as necessary and retighten the adjusting screw.

3. Tighten the lock nut (19) on the stationary lock.
 4. Loosen the adjustment screw (20) by turning counter-clockwise 1 1/2 turns. The locking mechanism is now properly adjusted.
- Check that the secondary lock operates freely.
- Check the operation of the fifth wheel by locking and unlocking it several times.

CHECKING THE OPERATION OF THE FIFTH WHEEL

With the fifth wheel turned upright, it will function as follows:

When the swinging lock (6) is open, the release handle (16) will be in; the plunger (17) will extend into the throat area so that the step in the plunger is visible in the throat, as shown in FIGURE 18, and the secondary lock release handle (18) will be out, with the handle lug disengaged from the top plate casting.

FIGURE 18 Step in the plunger (17)

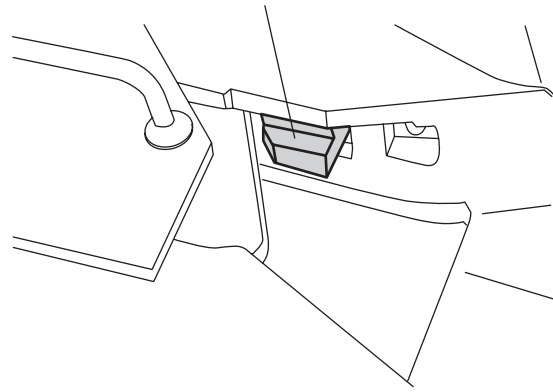

Fifth Wheel Coupling:

As the lock tester is coupled to the fifth wheel, the swinging lock closes, pushing the plunger (17) back, and the release handle (16) out.

As the swinging lock closes, the secondary lock spring will move the secondary lock into the closed position behind the swinging lock, and move the release handle inward. When properly locked, the locking plunger (17) will be visible as shown in FIGURE 18.

Fifth Wheel Uncoupling:

1. To uncouple the lock tester, pull the secondary lock release handle (9) out, raise it up and engage the handle lug with the top plate casting (FIGURE 19).
2. Then, pull the release handle (16) out, raise it up, and engage its handle lug with the top plate casting (FIGURE 15 on page 7). This will retract the plunger (17) and hold it in so that the step in the plunger is not visible in the throat area.

3. As the kingpin on the lock tester is pulled out (rearward), the swinging lock (6) will open.
- When the swinging lock opens, it will push the plunger back slightly, causing the release handle (16) to extend outward slightly. This action disengages the release handle from its notch in the casting, allowing the release handle to move to the locked position.
- As the swinging lock opens past the plunger, the plunger will extend into the throat area and become visible again. The release handle will move inward.
- As the swinging lock opens fully, it will contact the retracted secondary lock (10), pushing the secondary lock release handle slightly outward, causing its handle lug to disengage and allowing the handle to drop slightly.

FIGURE 19

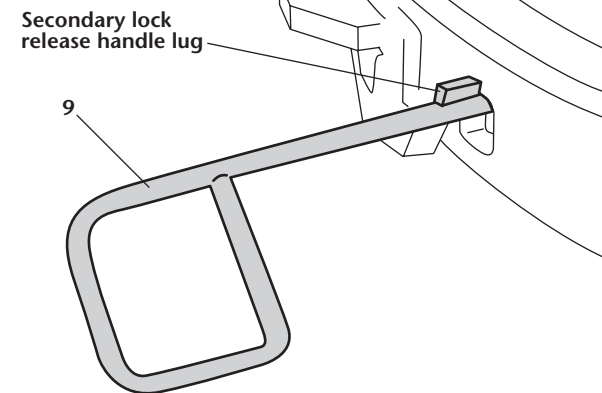

4. **IMPORTANT:** If the top plate assembly does not operate properly, **DO NOT USE IT.** Review the "Troubleshooting Hints" on page 2 and rebuilding procedures throughout this manual, or contact your local HOLLAND representative for assistance.

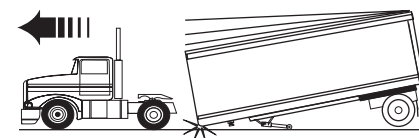

⚠ WARNING Failure to properly install, operate, or maintain this fifth wheel could result in tractor and trailer separation causing death or serious injury to others.

Primary Lock Installation *continued*

3. Place the secondary lock (10) into its approximate location in the casting (see FIGURE 4).

FIGURE 4

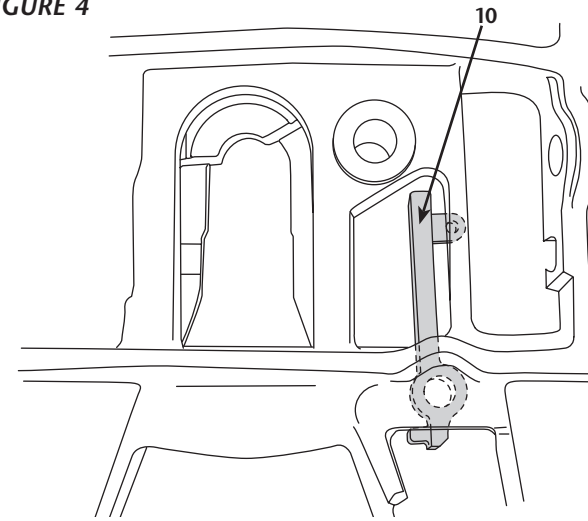

4. **IMPORTANT:** Coat the lock pin hole in the swinging lock (6) with Never-Seez® (supplied with kit). This is **vital. DO NOT USE** any substitute lubricant. (See FIGURE 5.)

5. Insert the swinging lock (6) between the ramps (see FIGURE 5). Temporarily set it under the rear rib.

FIGURE 5

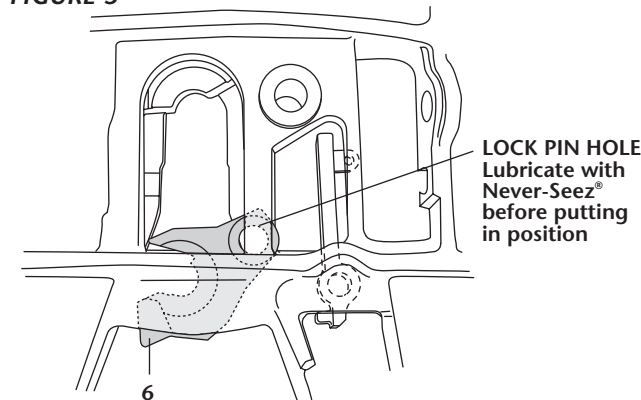

Plunger and Adjustment Wedge Installation

1. Install the adjusting screw (20) through the hole located in the throat of the fifth wheel casting. Install the compression spring (23) over the screw, then slide the adjusting wedge (22) over the screw (see FIGURE 6). Compress the spring and install a lock nut (21). Tighten the screw with a 1/2" Allen wrench until the nut is flush with the end of the bolt.

FIGURE 6

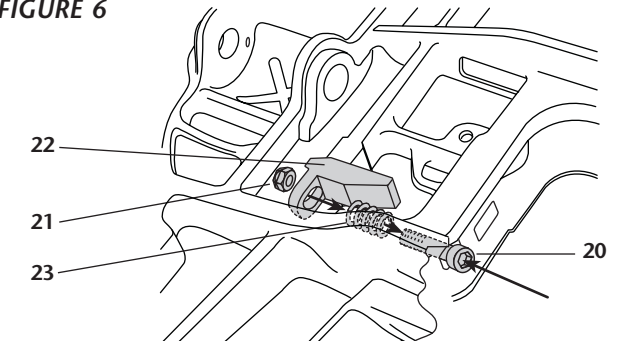

2. Lubricate the tail and faces of the plunger with a light grease (FIGURE 7).

FIGURE 7

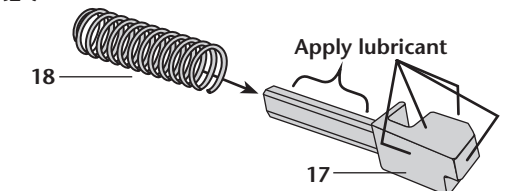

3. Install the spring (18) in the casting. See FIGURE 8.
4. Insert the plunger (17) through the plunger slots in the casting and the spring (18). Use the helper block to hold the plunger in place with the spring compressed (see FIGURE 8).

FIGURE 8

