

Processes



MIG (GMAW) Welding

Flux Cored (FCAW) Welding

Description



Wire Feeder

Olympic R-115

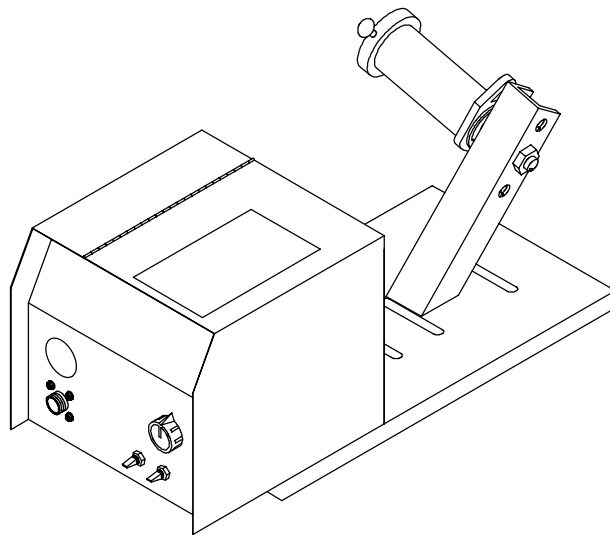

From Hobart to You

Thank you and congratulations on choosing Hobart. Now you can get the job done and get it done right. We know you don't have time to do it any other way.

This Owner's Manual is designed to help you get the most out of your Hobart products. Please take time to read the Safety precautions. They will help you

protect yourself against potential hazards on the worksite. We've made installation and operation quick and easy. With Hobart you can count on years of reliable service with proper maintenance. And if for some reason the unit needs repair, there's a Troubleshooting section that will help you figure out what the problem is. The parts list will then help you to decide which exact part you may need to fix the problem. Warranty and service information for your particular model are also provided.

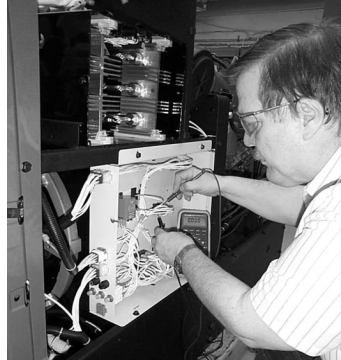

Hobart is registered to the ISO 9001 Quality System Standard.

Hobart Welders manufactures a full line of welders and welding related equipment. For information on other quality Hobart products, contact your local Hobart distributor to receive the latest full line catalog or individual catalog sheets. **To locate your nearest distributor or service agency call 1-877-Hobart1.**



Hobart offers a Technical Manual which provides more detailed service and parts information for your unit. To obtain a Technical Manual, contact your local distributor. Your distributor can also supply you with Welding Process Manuals such as SMAW, GTAW, GMAW, and GMAW-P.

HOBART[®]
WELDING PRODUCTS

TABLE OF CONTENTS

WARNING

This product, when used for welding or cutting, produces fumes or gases which contain chemicals known to the State of California to cause birth defects and, in some cases, cancer. (California Health & Safety Code Section 25249.5 et seq.)

SECTION 1 – SAFETY PRECAUTIONS - READ BEFORE USING	1
1-1. Symbol Usage	1
1-2. Arc Welding Hazards	1
1-3. Additional Symbols For Installation, Operation, And Maintenance	3
1-4. Principal Safety Standards	3
1-5. EMF Information	4
SECTION 1 – CONSIGNES DE SECURITE – LIRE AVANT UTILISATION	5
1-1. Signification des symboles	5
1-2. Dangers relatifs au soudage à l'arc	5
1-3. Dangers supplémentaires en relation avec l'installation, le fonctionnement et la maintenance	7
1-4. Principales normes de sécurité	8
1-5. Information sur les champs électromagnétiques	8
SECTION 2 – INSTALLATION	9
2-1. Specifications	9
2-2. Site Selection	9
2-3. Gun Recommendation Table	10
2-4. Equipment Connection Diagrams	10
2-5. Rear Panel Connections And Power Switch Location	10
2-6. Connecting Welding Gun And Weld Cable	11
2-7. Installing Wire Guide And Drive Roll	12
2-8. Installing And Threading Welding Wire	13
2-9. Interconnecting Power Cord Ground Lead Connection (All Models)	14
2-10. Connection For L-TEC Welding Power Sources With 7-Flat Socket Receptacle	14
2-11. Connection For Hobart Welding Power Sources With 19-Socket Receptacle	15
2-12. Connection For L-TEC Welding Power Sources With 19-Socket Receptacle	15
2-13. Connection For Hobart Welding Power Sources With 5-Socket And 115 Volts AC Receptacles	16
2-14. Connection For Lincoln Welding Power Sources With 14-Socket Receptacle	16
2-15. Connection For Lincoln Welding Power Sources With Terminal Strip Connections	17
2-16. Connection For AIRCO Welding Power Source With Two-Prong Twistlock And 115 Volts AC Receptacles	17
2-17. Connection For Welding Power Sources With Hubbell Receptacles	18
2-18. Connection For Miller Welding Power Sources With 14-Socket Receptacle	18
2-19. Motor Start/Burnback Control	19
SECTION 3 – OPERATION	20
3-1. Front Panel Controls	20
3-2. Optional Side Panel Controls	20
SECTION 4 – MAINTENANCE & TROUBLESHOOTING	21
4-1. Routine Maintenance	21
4-2. Overload Protection	21
4-3. Troubleshooting	22
SECTION 5 – ELECTRICAL DIAGRAM	23
SECTION 6 – PARTS LIST	24

SECTION 1 – SAFETY PRECAUTIONS - READ BEFORE USING

som_nd_4/98

1-1. Symbol Usage



Means Warning! Watch Out! There are possible hazards with this procedure! The possible hazards are shown in the adjoining symbols.

▲ Marks a special safety message.

☞ Means "Note"; not safety related.



This group of symbols means Warning! Watch Out! possible ELECTRIC SHOCK, MOVING PARTS, and HOT PARTS hazards. Consult symbols and related instructions below for necessary actions to avoid the hazards.

1-2. Arc Welding Hazards

▲ The symbols shown below are used throughout this manual to call attention to and identify possible hazards. When you see the symbol, watch out, and follow the related instructions to avoid the hazard. The safety information given below is only a summary of the more complete safety information found in the Safety Standards listed in Section 1-4. Read and follow all Safety Standards.

▲ Only qualified persons should install, operate, maintain, and repair this unit.

▲ During operation, keep everybody, especially children, away.



ELECTRIC SHOCK can kill.

Touching live electrical parts can cause fatal shocks or severe burns. The electrode and work circuit is electrically live whenever the output is on. The input power circuit and machine internal circuits are also

live when power is on. In semiautomatic or automatic wire welding, the wire, wire reel, drive roll housing, and all metal parts touching the welding wire are electrically live. Incorrectly installed or improperly grounded equipment is a hazard.

- Do not touch live electrical parts.
- Wear dry, hole-free insulating gloves and body protection.
- Insulate yourself from work and ground using dry insulating mats or covers big enough to prevent any physical contact with the work or ground.
- Do not use AC output in damp areas, if movement is confined, or if there is a danger of falling.
- Use AC output ONLY if required for the welding process.
- If AC output is required, use remote output control if present on unit.
- Disconnect input power or stop engine before installing or servicing this equipment. Lockout/tagout input power according to OSHA 29 CFR 1910.147 (see Safety Standards).
- Properly install and ground this equipment according to its Owner's Manual and national, state, and local codes.
- Always verify the supply ground – check and be sure that input power cord ground wire is properly connected to ground terminal in disconnect box or that cord plug is connected to a properly grounded receptacle outlet.
- When making input connections, attach proper grounding conductor first – double-check connections.
- Frequently inspect input power cord for damage or bare wiring – replace cord immediately if damaged – bare wiring can kill.
- Turn off all equipment when not in use.
- Do not use worn, damaged, undersized, or poorly spliced cables.
- Do not drape cables over your body.

- If earth grounding of the workpiece is required, ground it directly with a separate cable.
- Do not touch electrode if you are in contact with the work, ground, or another electrode from a different machine.
- Use only well-maintained equipment. Repair or replace damaged parts at once. Maintain unit according to manual.
- Wear a safety harness if working above floor level.
- Keep all panels and covers securely in place.
- Clamp work cable with good metal-to-metal contact to workpiece or worktable as near the weld as practical.
- Insulate work clamp when not connected to workpiece to prevent contact with any metal object.
- Do not connect more than one electrode or work cable to any single weld output terminal.

SIGNIFICANT DC VOLTAGE exists after removal of input power on inverters.

- Turn Off inverter, disconnect input power, and discharge input capacitors according to instructions in Maintenance Section before touching any parts.



FUMES AND GASES can be hazardous.

Welding produces fumes and gases. Breathing these fumes and gases can be hazardous to your health.

- Keep your head out of the fumes. Do not breathe the fumes.
- If inside, ventilate the area and/or use exhaust at the arc to remove welding fumes and gases.
- If ventilation is poor, use an approved air-supplied respirator.
- Read the Material Safety Data Sheets (MSDSs) and the manufacturer's instructions for metals, consumables, coatings, cleaners, and degreasers.
- Work in a confined space only if it is well ventilated, or while wearing an air-supplied respirator. Always have a trained watch-person nearby. Welding fumes and gases can displace air and lower the oxygen level causing injury or death. Be sure the breathing air is safe.
- Do not weld in locations near degreasing, cleaning, or spraying operations. The heat and rays of the arc can react with vapors to form highly toxic and irritating gases.
- Do not weld on coated metals, such as galvanized, lead, or cadmium plated steel, unless the coating is removed from the weld area, the area is well ventilated, and if necessary, while wearing an air-supplied respirator. The coatings and any metals containing these elements can give off toxic fumes if welded.



ARC RAYS can burn eyes and skin.

Arc rays from the welding process produce intense visible and invisible (ultraviolet and infrared) rays that can burn eyes and skin. Sparks fly off from the weld.

- Wear a welding helmet fitted with a proper shade of filter to protect your face and eyes when welding or watching (see ANSI Z49.1 and Z87.1 listed in Safety Standards).
- Wear approved safety glasses with side shields under your helmet.
- Use protective screens or barriers to protect others from flash and glare; warn others not to watch the arc.
- Wear protective clothing made from durable, flame-resistant material (leather and wool) and foot protection.



WELDING can cause fire or explosion.

Welding on closed containers, such as tanks, drums, or pipes, can cause them to blow up. Sparks can fly off from the welding arc. The flying sparks, hot workpiece, and hot equipment can cause fires and burns. Accidental contact of electrode to metal objects can cause sparks, explosion, overheating, or fire. Check and be sure the area is safe before doing any welding.

- Protect yourself and others from flying sparks and hot metal.
- Do not weld where flying sparks can strike flammable material.
- Remove all flammables within 35 ft (10.7 m) of the welding arc. If this is not possible, tightly cover them with approved covers.
- Be alert that welding sparks and hot materials from welding can easily go through small cracks and openings to adjacent areas.
- Watch for fire, and keep a fire extinguisher nearby.
- Be aware that welding on a ceiling, floor, bulkhead, or partition can cause fire on the hidden side.
- Do not weld on closed containers such as tanks, drums, or pipes, unless they are properly prepared according to AWS F4.1 (see Safety Standards).
- Connect work cable to the work as close to the welding area as practical to prevent welding current from traveling long, possibly unknown paths and causing electric shock and fire hazards.
- Do not use welder to thaw frozen pipes.
- Remove stick electrode from holder or cut off welding wire at contact tip when not in use.
- Wear oil-free protective garments such as leather gloves, heavy shirt, cuffless trousers, high shoes, and a cap.
- Remove any combustibles, such as a butane lighter or matches, from your person before doing any welding.

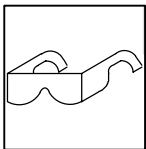

FLYING METAL can injure eyes.

- Welding, chipping, wire brushing, and grinding cause sparks and flying metal. As welds cool, they can throw off slag.
- Wear approved safety glasses with side shields even under your welding helmet.



BUILDUP OF GAS can injure or kill.

- Shut off shielding gas supply when not in use.
- Always ventilate confined spaces or use approved air-supplied respirator.



HOT PARTS can cause severe burns.

- Do not touch hot parts bare handed.
- Allow cooling period before working on gun or torch.

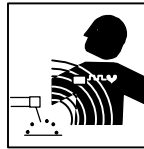

MAGNETIC FIELDS can affect pacemakers.

- Pacemaker wearers keep away.
- Wearers should consult their doctor before going near arc welding, gouging, or spot welding operations.

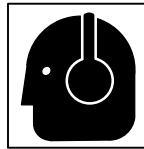

NOISE can damage hearing.

Noise from some processes or equipment can damage hearing.

- Wear approved ear protection if noise level is high.

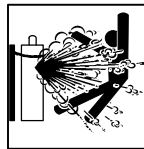

CYLINDERS can explode if damaged.

Shielding gas cylinders contain gas under high pressure. If damaged, a cylinder can explode. Since gas cylinders are normally part of the welding process, be sure to treat them carefully.

- Protect compressed gas cylinders from excessive heat, mechanical shocks, slag, open flames, sparks, and arcs.
- Install cylinders in an upright position by securing to a stationary support or cylinder rack to prevent falling or tipping.
- Keep cylinders away from any welding or other electrical circuits.
- Never drape a welding torch over a gas cylinder.
- Never allow a welding electrode to touch any cylinder.
- Never weld on a pressurized cylinder – explosion will result.
- Use only correct shielding gas cylinders, regulators, hoses, and fittings designed for the specific application; maintain them and associated parts in good condition.
- Turn face away from valve outlet when opening cylinder valve.
- Keep protective cap in place over valve except when cylinder is in use or connected for use.
- Read and follow instructions on compressed gas cylinders, associated equipment, and CGA publication P-1 listed in Safety Standards.

1-3. Additional Symbols For Installation, Operation, And Maintenance



FIRE OR EXPLOSION hazard.

- Do not install or place unit on, over, or near combustible surfaces.
- Do not install unit near flammables.
- Do not overload building wiring – be sure power supply system is properly sized, rated, and protected to handle this unit.



MOVING PARTS can cause injury.

- Keep away from moving parts such as fans.
- Keep all doors, panels, covers, and guards closed and securely in place.



FALLING UNIT can cause injury.

- Use lifting eye to lift unit only, NOT running gear, gas cylinders, or any other accessories.
- Use equipment of adequate capacity to lift and support unit.
- If using lift forks to move unit, be sure forks are long enough to extend beyond opposite side of unit.

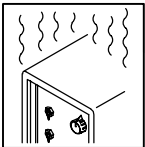

OVERUSE can cause OVERHEATING

- Allow cooling period; follow rated duty cycle.
- Reduce current or reduce duty cycle before starting to weld again.
- Do not block or filter airflow to unit.



STATIC (ESD) can damage PC boards.

- Put on grounded wrist strap BEFORE handling boards or parts.
- Use proper static-proof bags and boxes to store, move, or ship PC boards.



MOVING PARTS can cause injury.

- Keep away from moving parts.
- Keep away from pinch points such as drive rolls.



WELDING WIRE can cause injury.

- Do not press gun trigger until instructed to do so.
- Do not point gun toward any part of the body, other people, or any metal when threading welding wire.

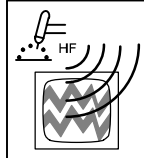

H.F. RADIATION can cause interference.

- High-frequency (H.F.) can interfere with radio navigation, safety services, computers, and communications equipment.
- Have only qualified persons familiar with electronic equipment perform this installation.
- The user is responsible for having a qualified electrician promptly correct any interference problem resulting from the installation.
- If notified by the FCC about interference, stop using the equipment at once.
- Have the installation regularly checked and maintained.
- Keep high-frequency source doors and panels tightly shut, keep spark gaps at correct setting, and use grounding and shielding to minimize the possibility of interference.

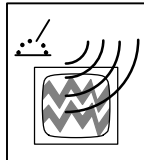

ARC WELDING can cause interference.

- Electromagnetic energy can interfere with sensitive electronic equipment such as computers and computer-driven equipment such as robots.
- Be sure all equipment in the welding area is electromagnetically compatible.
- To reduce possible interference, keep weld cables as short as possible, close together, and down low, such as on the floor.
- Locate welding operation 100 meters from any sensitive electronic equipment.
- Be sure this welding machine is installed and grounded according to this manual.
- If interference still occurs, the user must take extra measures such as moving the welding machine, using shielded cables, using line filters, or shielding the work area.

1-4. Principal Safety Standards

Safety in Welding and Cutting, ANSI Standard Z49.1, from American Welding Society, 550 N.W. LeJeune Rd, Miami FL 33126

Safety and Health Standards, OSHA 29 CFR 1910, from Superintendent of Documents, U.S. Government Printing Office, Washington, D.C. 20402.

Recommended Safe Practices for the Preparation for Welding and Cutting of Containers That Have Held Hazardous Substances, American Welding Society Standard AWS F4.1, from American Welding Society, 550 N.W. LeJeune Rd, Miami, FL 33126

National Electrical Code, NFPA Standard 70, from National Fire Protection Association, Batterymarch Park, Quincy, MA 02269.

Safe Handling of Compressed Gases in Cylinders, CGA Pamphlet P-1, from Compressed Gas Association, 1235 Jefferson Davis Highway, Suite 501, Arlington, VA 22202.

Code for Safety in Welding and Cutting, CSA Standard W117.2, from Canadian Standards Association, Standards Sales, 178 Rexdale Boulevard, Rexdale, Ontario, Canada M9W 1R3.

Safe Practices For Occupation And Educational Eye And Face Protection, ANSI Standard Z87.1, from American National Standards Institute, 1430 Broadway, New York, NY 10018.

Cutting And Welding Processes, NFPA Standard 51B, from National Fire Protection Association, Batterymarch Park, Quincy, MA 02269.

1-5. EMF Information

Considerations About Welding And The Effects Of Low Frequency Electric And Magnetic Fields

Welding current, as it flows through welding cables, will cause electromagnetic fields. There has been and still is some concern about such fields. However, after examining more than 500 studies spanning 17 years of research, a special blue ribbon committee of the National Research Council concluded that: "The body of evidence, in the committee's judgment, has not demonstrated that exposure to power-frequency electric and magnetic fields is a human-health hazard." However, studies are still going forth and evidence continues to be examined. Until the final conclusions of the research are reached, you may wish to minimize your exposure to electromagnetic fields when welding or cutting.

To reduce magnetic fields in the workplace, use the following procedures:

1. Keep cables close together by twisting or taping them.
2. Arrange cables to one side and away from the operator.
3. Do not coil or drape cables around your body.
4. Keep welding power source and cables as far away from operator as practical.
5. Connect work clamp to workpiece as close to the weld as possible.

About Pacemakers:

Pacemaker wearers consult your doctor first. If cleared by your doctor, then following the above procedures is recommended.

SECTION 1 – CONSIGNES DE SECURITE – LIRE AVANT UTILISATION

som _nd_fre 4/98

1-1. Signification des symboles



Signifie Mise en garde ! Soyez vigilant ! Cette procédure présente des risques de danger ! Ceux-ci sont identifiés par des symboles adjacents aux directives.

▲ Identifie un message de sécurité particulier.

Signifie NOTA ; n'est pas relatif à la sécurité.



Ce groupe de symboles signifie Mise en garde ! Soyez vigilant ! Il y a des risques de danger reliés aux CHOCS ÉLECTRIQUES, aux PIÈCES EN MOUVEMENT et aux PIÈCES CHAUDES. Reportez-vous aux symboles et aux directives ci-dessous afin de connaître les mesures à prendre pour éviter tout danger.

1-2. Dangers relatifs au soudage à l'arc

▲ Les symboles présentés ci-après sont utilisés tout au long du présent manuel pour attirer votre attention et identifier les risques de danger. Lorsque vous voyez un symbole, soyez vigilant et suivez les directives mentionnées afin d'éviter tout danger. Les consignes de sécurité présentées ci-après ne font que résumer l'information contenue dans les normes de sécurité énumérées à la section 1-4. Veuillez lire et respecter toutes ces normes de sécurité.

▲ L'installation, l'utilisation, l'entretien et les réparations ne doivent être confiés qu'à des personnes qualifiées.

▲ Au cours de l'utilisation, tenir toute personne à l'écart et plus particulièrement les enfants.



UN CHOC ÉLECTRIQUE peut tuer.

Un simple contact avec des pièces électriques peut provoquer une électrocution ou des blessures graves. L'électrode et le circuit de soudage sont sous tension dès que l'appareil est sur ON. Le circuit d'entrée et les circuits internes de l'appareil sont également sous tension à ce moment-là. En soudage semi-automatique ou automatique, le fil, le dévidoir, le logement des galets d'entraînement et les pièces métalliques en contact avec le fil de soudage sont sous tension. Des matériels mal installés ou mal mis à la terre présentent un danger.

- Ne jamais toucher les pièces électriques sous tension.
- Porter des gants et des vêtements de protection secs ne comportant pas de trous.
- S'isoler de la pièce et de la terre au moyen de tapis ou d'autres moyens isolants suffisamment grands pour empêcher le contact physique éventuel avec la pièce ou la terre.
- Ne pas se servir de source électrique à courant électrique dans les zones humides, dans les endroits confinés ou là où on risque de tomber.
- Se servir d'une source électrique à courant électrique UNIQUEMENT si le procédé de soudage le demande.
- Si l'utilisation d'une source électrique à courant électrique s'avère nécessaire, se servir de la fonction de télécommande si l'appareil en est équipé.
- Couper l'alimentation ou arrêter le moteur avant de procéder à l'installation, à la réparation ou à l'entretien de l'appareil. Déverrouiller l'alimentation selon la norme OSHA 29 CFR 1910.147 (voir normes de sécurité).
- Installer et mettre à la terre correctement cet appareil conformément à son manuel d'utilisation et aux codes nationaux, provinciaux et municipaux.
- Toujours vérifier la terre du cordon d'alimentation – Vérifier et s'assurer que le fil de terre du cordon d'alimentation est bien raccordé à la borne de terre du sectionneur ou que la fiche du cordon est raccordée à une prise correctement mise à la terre.
- En effectuant les raccordements d'entrée fixer d'abord le conducteur de mise à la terre approprié et contre-vérifier les connexions.
- Vérifier fréquemment le cordon d'alimentation pour voir s'il n'est pas endommagé ou dénudé – remplacer le cordon immédiatement s'il est endommagé – un câble dénudé peut provoquer une électrocution.
- Mettre l'appareil hors tension quand on ne l'utilise pas.
- Ne pas utiliser des câbles usés, endommagés, de grosseur insuffisante ou mal épissés.
- Ne pas enrouler les câbles autour du corps.
- Si la pièce soudée doit être mise à la terre, le faire directement avec un câble distinct.
- Ne pas toucher l'électrode quand on est en contact avec la pièce, la terre ou une électrode provenant d'une autre machine.

- N'utiliser qu'un matériel en bon état. Réparer ou remplacer sur-le-champ les pièces endommagées. Entretien l'appareil conformément à ce manuel.
- Porter un harnais de sécurité quand on travaille en hauteur.
- Maintenir solidement en place tous les panneaux et capots.
- Fixer le câble de retour de façon à obtenir un bon contact métal-métal avec la pièce à souder ou la table de travail, le plus près possible de la soudure.
- Isoler la pince de masse quand pas mis à la pièce pour éviter le contact avec tout objet métallique.

Il y a DU COURANT CONTINU IMPORTANT dans les convertisseurs après la suppression de l'alimentation électrique.

- Arrêter les convertisseurs, débrancher le courant électrique, et décharger les condensateurs d'alimentation selon les instructions indiquées dans la partie entretien avant de toucher les pièces.

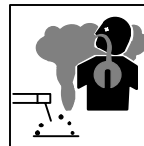

LES FUMÉES ET LES GAZ peuvent être dangereux.

Le soudage génère des fumées et des gaz. Leur inhalation peut être dangereuse pour votre santé.

- Eloigner votre tête des fumées. Ne pas respirer les fumées.
- A l'intérieur, ventiler la zone et/ou utiliser un échappement au niveau de l'arc pour l'évacuation des fumées et des gaz de soudage.
- Si la ventilation est insuffisante, utiliser un respirateur à alimentation d'air homologué.
- Lire les spécifications de sécurité des matériaux (MSDSs) et les instructions du fabricant concernant les métaux, les consommables, les revêtements, les nettoyants et les dégraissants.
- Travailler dans un espace fermé seulement s'il est bien ventilé ou en portant un respirateur à alimentation d'air. Demander toujours à un surveillant dûment formé de se tenir à proximité. Des fumées et des gaz de soudage peuvent déplacer l'air et abaisser le niveau d'oxygène provoquant des blessures ou des accidents mortels. S'assurer que l'air de respiration ne présente aucun danger.
- Ne pas souder dans des endroits situés à proximité d'opérations de dégraissage, de nettoyage ou de pulvérisation. La chaleur et les rayons de l'arc peuvent réagir en présence de vapeurs et former des gaz hautement toxiques et irritants.
- Ne pas souder des métaux munis d'un revêtement, tels que l'acier galvanisé, plaqué en plomb ou au cadmium à moins que le revêtement n'ait été enlevé dans la zone de soudure, que l'endroit soit bien ventilé, et si nécessaire, en portant un respirateur à alimentation d'air. Les revêtements et tous les métaux renfermant ces éléments peuvent dégager des fumées toxiques en cas de soudage.



LES RAYONS DE L'ARC peuvent provoquer des brûlures dans les yeux et sur la peau.

Le rayonnement de l'arc du procédé de soudage génère des rayons visibles et invisibles intenses (ultraviolets et infrarouges) susceptibles de provoquer des brûlures dans les yeux et sur la peau. Des étincelles sont projetées pendant le soudage.

- Porter un casque de soudage muni d'un écran de filtre approprié pour protéger votre visage et vos yeux pendant le soudage ou pour regarder (voir ANSI Z49.1 et Z87.1 énuméré dans les normes de sécurité).
- Porter des protections approuvés pour les oreilles si le niveau sonore est trop élevé.
- Utiliser des écrans ou des barrières pour protéger des tiers de l'éclair et de l'éblouissement; demander aux autres personnes de ne pas regarder l'arc.
- Porter des vêtements de protection constitué dans une matière durable, résistant au feu (cuir ou laine) et une protection des pieds.



LE SOUDAGE peut provoquer un incendie ou une explosion.

Le soudage effectué sur des conteneurs fermés tels que des réservoirs, tambours ou des conduites peut provoquer leur éclatement. Des étincelles peuvent être projetées de l'arc de soudure. La projection d'étincelles, des pièces chaudes et des équipements chauds peut provoquer des incendies et des brûlures. Le contact accidentel de l'électrode avec des objets métalliques peut provoquer des étincelles, une explosion, un surchauffement ou un incendie. Avant de commencer le soudage, vérifier et s'assurer que l'endroit ne présente pas de danger.

- Se protéger et d'autres personnes de la projection d'étincelles et de métal chaud.
- Ne pas souder dans un endroit là où des étincelles peuvent tomber sur des substances inflammables.
- Déplacer toutes les substances inflammables à une distance de 10,7 m de l'arc de soudage. En cas d'impossibilité les recouvrir soigneusement avec des protections homologués.
- Des étincelles et des matériaux chauds du soudage peuvent facilement passer dans d'autres zones en traversant de petites fissures et des ouvertures.
- Surveiller tout déclenchement d'incendie et tenir un extincteur à proximité.
- Le soudage effectué sur un plafond, plancher, paroi ou séparation peut déclencher un incendie de l'autre côté.
- Ne pas effectuer le soudage sur des conteneurs fermés tels que des réservoirs, tambours, ou conduites, à moins qu'ils n'aient été préparés correctement conformément à AWS F4.1 (voir les normes de sécurité).
- Brancher le câble sur la pièce le plus près possible de la zone de soudage pour éviter le transport du courant sur une longue distance par des chemins inconnus éventuels en provoquant des risques d'électrocution et d'incendie.
- Ne pas utiliser le poste de soudage pour dégelier des conduites gelées.
- En cas de non utilisation, enlever la bague d'électrode du porte-électrode ou couper le fil à la pointe de contact.
- Porter des vêtements de protection dépourvus d'huile tels que des gants en cuir, une chemise en matériau lourd, des pantalons sans revers, des chaussures hautes et un couvre chef.
- Avant de souder, retirer toute substance combustible de vos poches telles qu'un allumeur au butane ou des allumettes.



DES PARTICULES VOLANTES peuvent blesser les yeux.

- Le soudage, l'écaillage, le passage de la pièce à la brosse en fil de fer, et le meulage génèrent des étincelles et des particules métalliques volantes. Pendant la période de refroidissement des soudures, elles risquent de projeter du laitier.
 - Porter des lunettes de sécurité avec écrans latéraux ou un écran facial.



LES ACCUMULATIONS DE GAZ risquent de provoquer des blessures ou même la mort.

- Fermer l'alimentation du gaz protecteur en cas de non utilisation.
 - Veiller toujours à bien aérer les espaces confinés ou se servir d'un respirateur d'adduction d'air homologué.



DES PIÈCES CHAUDES peuvent provoquer des brûlures graves.

- Ne pas toucher des parties chaudes à mains nues
- Prévoir une période de refroidissement avant d'utiliser le pistolet ou la torche.

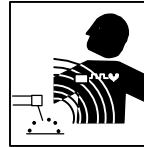

LES CHAMPS MAGNÉTIQUES peuvent affecter les stimulateurs cardiaques.

- Porteurs de stimulateur cardiaque, restez à distance.
- Les porteurs d'un stimulateur cardiaque doivent d'abord consulter leur médecin avant de s'approcher des opérations de soudage à l'arc, de gougeage ou de soudage par points.

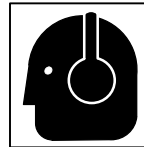

LE BRUIT peut affecter l'ouïe.

Le bruit des processus et des équipements peut affecter l'ouïe.

- Porter des protections approuvés pour les oreilles si le niveau sonore est trop élevé.

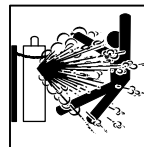

Si des BOUTEILLES sont endommagées, elles pourront exploser.

Des bouteilles de gaz protecteur contiennent du gaz sous haute pression. Si une bouteille est endommagée, elle peut exploser. Du fait que les bouteilles de gaz font normalement partie du procédé de soudage, les manipuler avec précaution.

- Protéger les bouteilles de gaz comprimé d'une chaleur excessive, des chocs mécaniques, du laitier, des flammes ouvertes, des étincelles et des arcs.
- Placer les bouteilles debout en les fixant dans un support stationnaire ou dans un porte-bouteilles pour les empêcher de tomber ou de se renverser.
- Tenir les bouteilles éloignées des circuits de soudage ou autres circuits électriques.
- Ne jamais placer une torche de soudage sur une bouteille à gaz.
- Une électrode de soudage ne doit jamais entrer en contact avec une bouteille.
- Ne jamais souder une bouteille pressurisée – risque d'explosion.
- Utiliser seulement des bouteilles de gaz protecteur, régulateurs, tuyaux et raccords convenables pour cette application spécifique; les maintenir ainsi que les éléments associés en bon état.
- Ne pas tenir la tête en face de la sortie en ouvrant la soupape de la bouteille.
- Maintenir le chapeau de protection sur la soupape, sauf en cas d'utilisation ou de branchement de la bouteille.
- Lire et suivre les instructions concernant les bouteilles de gaz comprimé, les équipements associés et les publications P-1 CGA énumérées dans les normes de sécurité.

1-3. Dangers supplémentaires en relation avec l'installation, le fonctionnement et la maintenance



Risque D'INCENDIE OU D'EXPLOSION.

- Ne pas placer l'appareil sur, au-dessus ou à proximité de surfaces inflammables.
- Ne pas installer l'appareil à proximité de produits inflammables
- Ne pas surcharger l'installation électrique – s'assurer que l'alimentation est correctement dimensionnée et protégée avant de mettre l'appareil en service.



LA CHUTE DE L'APPAREIL peut blesser.

- Utiliser l'anneau de levage uniquement pour soulever l'appareil, NON PAS les chariot, les bouteilles de gaz ou tout autre accessoire.
- Utiliser un engin d'une capacité appropriée pour soulever l'appareil.
- En utilisant des fourches de levage pour déplacer l'unité, s'assurer que les fourches sont suffisamment longues pour dépasser du côté opposé de l'appareil.

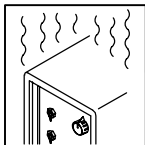

L'EMPLOI EXCESSIF peut SURCHAUFFER L'ÉQUIPEMENT.

- Prévoir une période de refroidissement, respecter le cycle opératoire nominal.
- Réduire le courant ou le cycle opératoire avant de recommencer le soudage.
- Ne pas obstruer les passages d'air du poste.

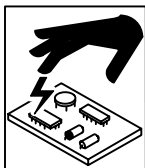

LES CHARGES ÉLECTROSTATIQUES peuvent endommager les circuits imprimés.

- Établir la connexion avec la barrette de terre avant de manipuler des cartes ou des pièces.
- Utiliser des pochettes et des boîtes antistatiques pour stocker, déplacer ou expédier des cartes de circuits imprimés.

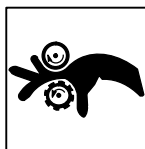

DES ORGANES MOBILES peuvent provoquer des blessures.

- Ne pas s'approcher des organes mobiles.
- Ne pas s'approcher des points de coincement tels que des rouleaux de commande.



LES FILS DE SOUDAGE peuvent provoquer des blessures.

- Ne pas appuyer sur la gachette avant d'en avoir reçu l'instruction.
- Ne pas diriger le pistolet vers soi, d'autres personnes ou toute pièce mécanique en engageant le fil de soudage.



DES ORGANES MOBILES peuvent provoquer des blessures.

- Rester à l'écart des organes mobiles comme le ventilateur.
- Maintenir fermés et fixement en place les portes, panneaux, recouvrements et dispositifs de protection.

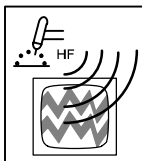

LE RAYONNEMENT HAUTE FRÉQUENCE (H.F.) risque de provoquer des interférences.

- Le rayonnement haute fréquence peut provoquer des interférences avec les équipements de radio-navigation et de communication, les services de sécurité et les ordinateurs.
- Demander seulement à des personnes qualifiées familiarisées avec des équipements électroniques de faire fonctionner l'installation.
- L'utilisateur est tenu de faire corriger rapidement par un électricien qualifié les interférences résultant de l'installation.
- Si le FCC signale des interférences, arrêter immédiatement l'appareil.
- Effectuer régulièrement le contrôle et l'entretien de l'installation.
- Maintenir soigneusement fermés les portes et les panneaux des sources de haute fréquence, maintenir les éclateurs à une distance correcte et utiliser une terre et un blindage pour réduire les interférences éventuelles.

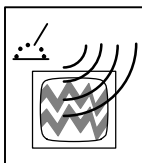

LE SOUDAGE À L'ARC risque de provoquer des interférences.

- L'énergie électromagnétique risque de provoquer des interférences pour l'équipement électronique sensible tel que les ordinateurs et l'équipement commandé par ordinateur tel que les robots.
- Veiller à ce que tout l'équipement de la zone de soudage soit compatible électromagnétiquement.
- Pour réduire la possibilité d'interférence, maintenir les câbles de soudage aussi courts que possible, les grouper, et les poser aussi bas que possible (ex. par terre).
- Veiller à souder à une distance de 100 mètres de tout équipement électronique sensible.
- Veiller à ce que ce poste de soudage soit posé et mis à la terre conformément à ce mode d'emploi.
- En cas d'interférences après avoir pris les mesures précédentes, il incombe à l'utilisateur de prendre des mesures supplémentaires telles que le déplacement du poste, l'utilisation de câbles blindés, l'utilisation de filtres de ligne ou la pose de protecteurs dans la zone de travail.

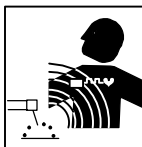

LES CHAMPS MAGNÉTIQUES peuvent affecter les stimulateurs cardiaques.

- Porteurs de stimulateur cardiaque, restez à distance.
- Les porteurs d'un stimulateur cardiaque doivent d'abord consulter leur médecin avant de s'approcher des opérations de soudage à l'arc, de gougeage ou de soudage par points.

1-4. Principales normes de sécurité

Safety in Welding and Cutting, norme ANSI Z49.1, de l'American Welding Society, 550 N.W. Lejeune Rd, Miami FL 33126

Safety and Health Standards, OSHA 29 CFR 1910, du Superintendent of Documents, U.S. Government Printing Office, Washington, D.C. 20402.

Recommended Safe Practice for the Preparation for Welding and Cutting of Containers That Have Held Hazardous Substances, norme AWS F4.1, de l'American Welding Society, 550 N.W. Lejeune Rd, Miami FL 33126

National Electrical Code, NFPA Standard 70, de la National Fire Protection Association, Batterymarch Park, Quincy, MA 02269.

Safe Handling of Compressed Gases in Cylinders, CGA Pamphlet P-1, de la Compressed Gas Association, 1235 Jefferson Davis Highway, Suite 501, Arlington, VA 22202.

Règles de sécurité en soudage, coupage et procédés connexes, norme CSA W117.2, de l'Association canadienne de normalisation, vente de normes, 178 Rexdale Boulevard, Rexdale (Ontario) Canada M9W 1R3.

Safe Practices For Occupation And Educational Eye And Face Protection, norme ANSI Z87.1, de l'American National Standards Institute, 1430 Broadway, New York, NY 10018.

Cutting and Welding Processes, norme NFPA 51B, de la National Fire Protection Association, Batterymarch Park, Quincy, MA 02269.

1-5. Information sur les champs électromagnétiques

Données sur le soudage électrique et sur les effets, pour l'organisme, des champs magnétiques basse fréquence

Le courant de soudage, pendant son passage dans les câbles de soudage, causera des champs électromagnétiques. Il y a eu et il y a encore un certain souci à propos de tels champs. Cependant, après avoir examiné plus de 500 études qui ont été faites pendant une période de recherche de 17 ans, un comité spécial ruban bleu du National Research Council a conclu: "L'accumulation de preuves, suivant le jugement du comité, n'a pas démontré que l'exposition aux champs magnétiques et champs électriques à haute fréquence représente un risque à la santé humaine". Toutefois, des études sont toujours en cours et les preuves continuent à être examinées. En attendant que les conclusions finales de la recherche soient établies, il vous serait souhaitable de réduire votre exposition aux champs électromagnétiques pendant le soudage ou le coupage.

Afin de réduire les champs électromagnétiques dans l'environnement de travail, respecter les consignes suivantes :

- 1 Garder les câbles ensemble en les torsadant ou en les attachant avec du ruban adhésif.
- 2 Mettre tous les câbles du côté opposé de l'opérateur.
- 3 Ne pas courber pas et ne pas entourer pas les câbles autour de votre corps.
- 4 Garder le poste de soudage et les câbles le plus loin possible de vous.
- 5 Relier la pince de masse le plus près possible de la zone de soudure.

Consignes relatives aux stimulateurs cardiaques :

Les personnes qui portent un stimulateur cardiaque doivent avant tout consulter leur docteur. Si vous êtes déclaré apte par votre docteur, il est alors recommandé de respecter les consignes ci-dessus.

SECTION 2 – INSTALLATION

2-1. Specifications

Type of Input Power	Welding Power Source Type	Wire Feed Speed Range	Wire Diameter Range	Welding Circuit Rating	Overall Dimensions	Weight
115 Volts AC Single Phase 2 Amperes 50/60 Hz	Constant Voltage (CV) DC And Contactor Control	75 to 750 ipm (1.9 To 19 mpm)	.030 To 3/32 in (0.8 To 2.4 mm) Max Spool Weight: 60 lb (27 kg)	100 Volts, 500 Amperes, 100% Duty Cycle	Length: 23-1/2 in (597 mm) Width: 10-3/4 in (273 mm) Height: 11 in (279 mm)	40 lb (18 kg)

2-2. Site Selection

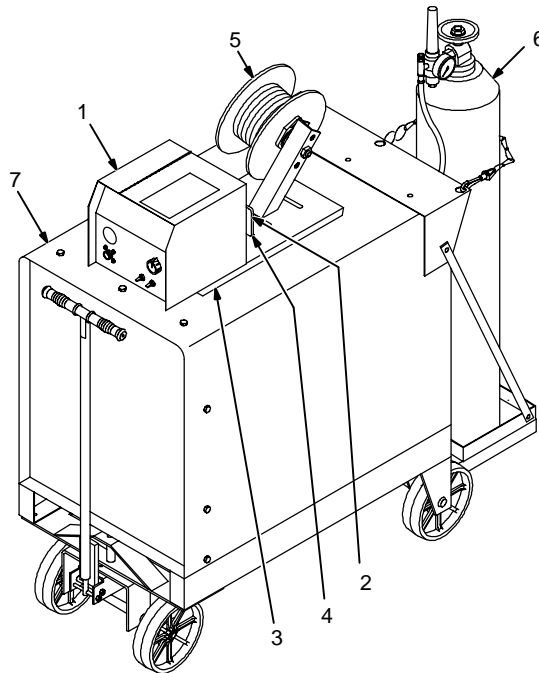
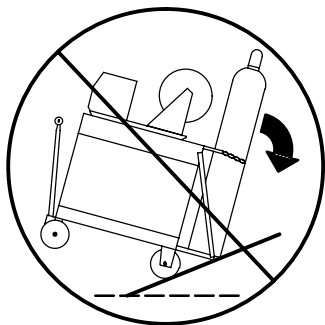
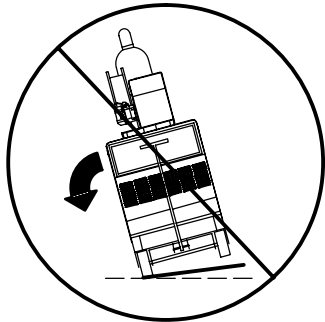
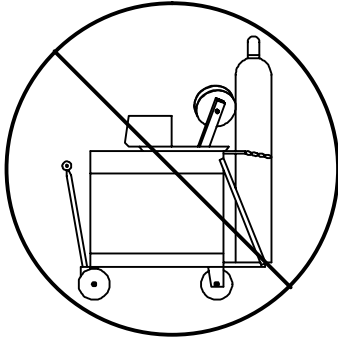

- 1 Wire Feeder
- 2 Lifting Eye
- 3 Rubber Feet
- 4 Slot

Choose slot that allows all rubber feet to sit securely on top of welding power source.

- 5 Wire Spool/Reel
- 6 Gas Cylinder (Customer Supplied)
- 7 Welding Power Source

▲ Do not put feeder where welding wire hits cylinder.

▲ Do not move or operate equipment when it could tip.

2-3. Gun Recommendation Table

Process	Gun
GMAW – Hard or Corded Wires	M25 Or M40
FCAW – Self-Shielding Wires	GA-40GL

2-4. Equipment Connection Diagrams

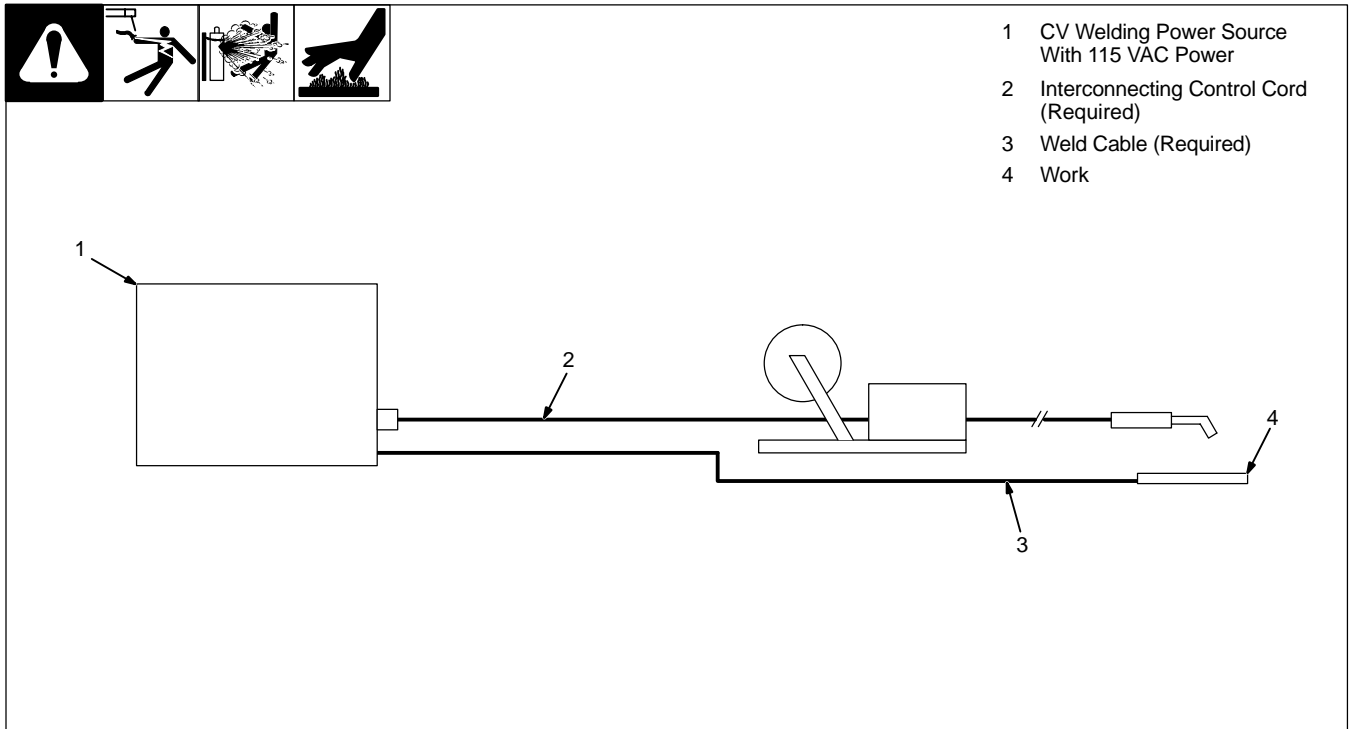

2-5. Rear Panel Connections And Power Switch Location

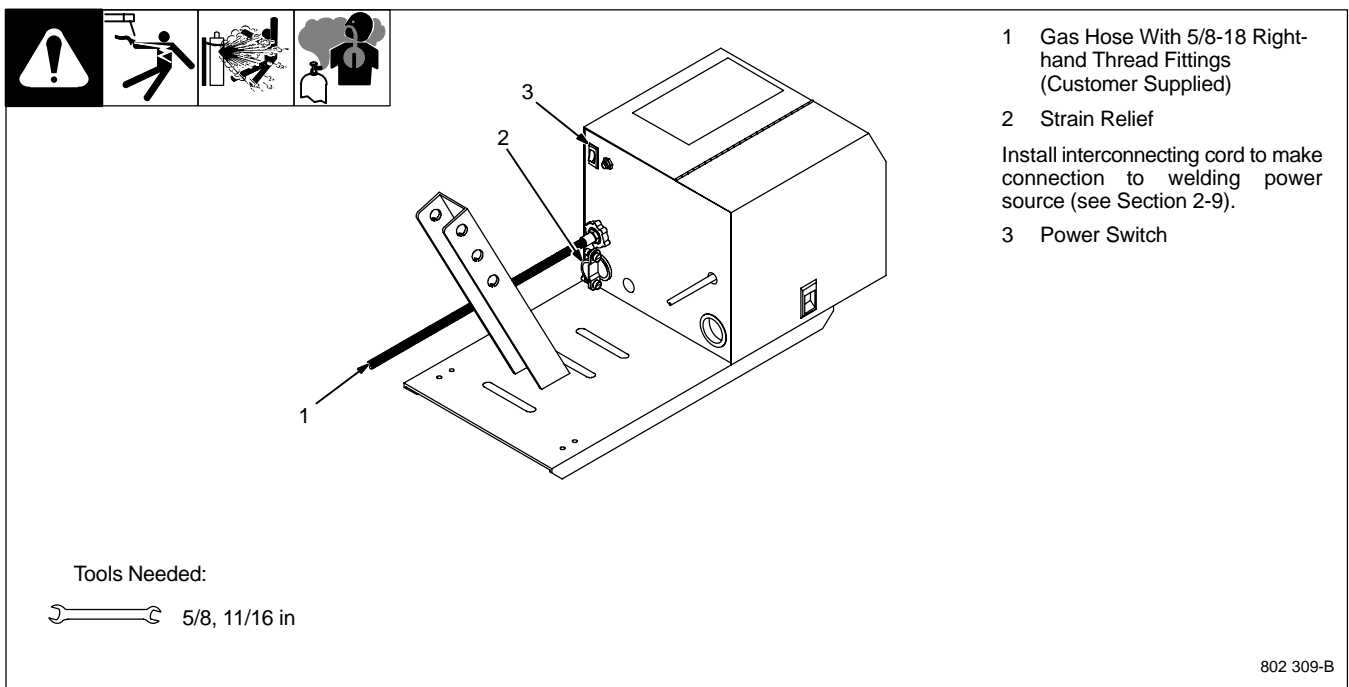

802 309-B

2-6. Connecting Welding Gun And Weld Cable

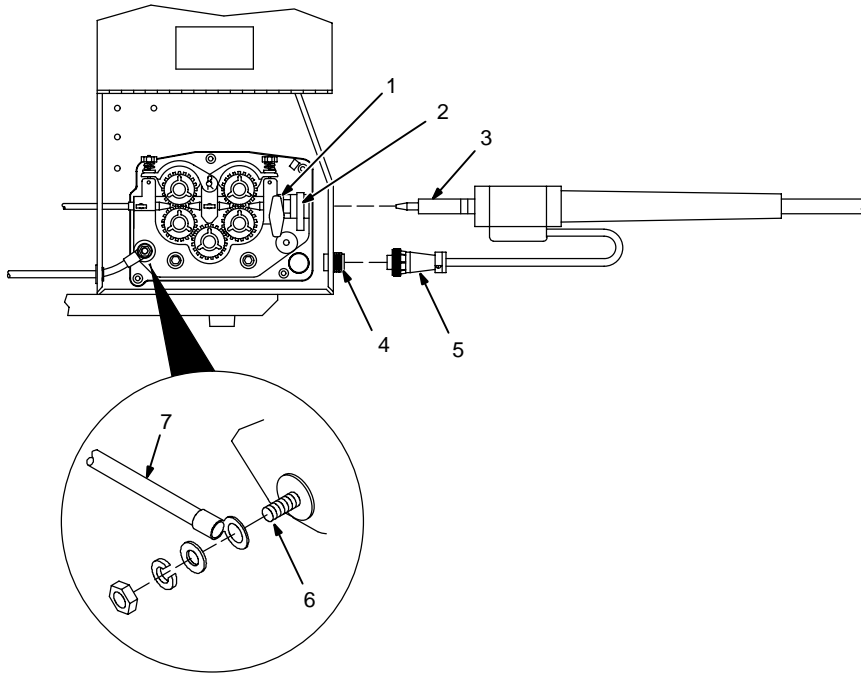

- 1 Gun Securing Knob
- 2 Gun Block
- 3 Gun Outlet Wire Guide

Loosen knob, insert gun into block. Position outlet wire guide as close as possible to drive rolls without touching. Tighten knob.

- 4 Gun Trigger Receptacle
- 5 Gun Trigger Plug
- 6 Weld Cable Terminal
- 7 Weld Cable From Welding Power Source

Tools Needed:

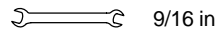

802 308

2-7. Installing Wire Guide And Drive Roll

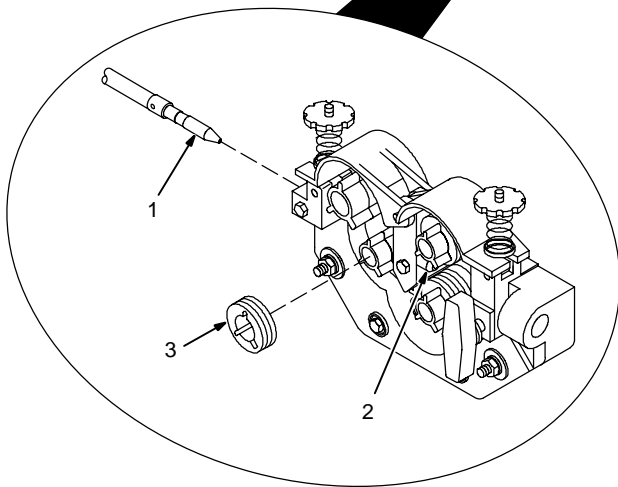
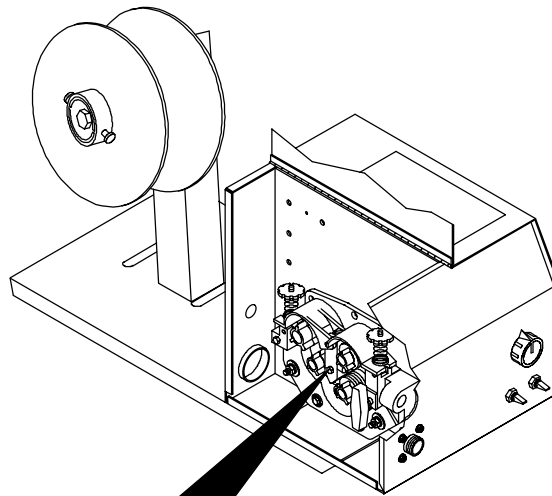

- 1 Inlet Wire Guide
- 2 Intermediate Wire Guide

Install and secure inlet wire guide, and intermediate wire guide.

- 3 Drive Roll (4)

Install drive rolls and turn drive roll nut one click.

During maintenance intervals, remove drive rolls, and clean grooves using a wire brush. Check groove of drive roll for pitting or increase in the depth of the groove indicating drive roll is worn out.

Tools Needed:

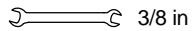

802 310-A

2-8. Installing And Threading Welding Wire

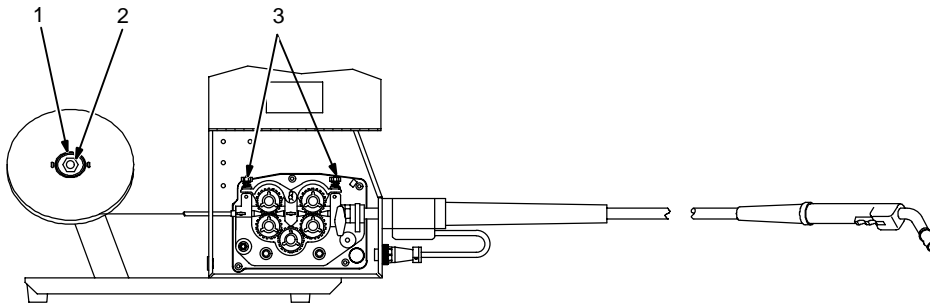
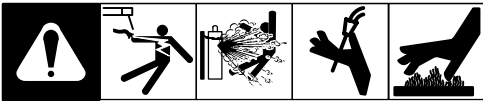

- 1 Retaining Ring
- 2 Hub Tension Adjustment Nut

If necessary, move hub on support for use of different size wire spool.

Remove retaining ring, and install spool so hub pin fits spool hole. Reinstall retaining ring.

Adjust tension nut so wire is taut when wire feed stops.

- 3 Pressure Assembly Adjustment Knob

Lay gun cable out straight.

A Open pressure assemblies, hold wire tightly, and cut off end. Push wire through guides into gun.

B Close and tighten pressure assemblies. Press JOG button until the wire comes out of the gun.

C To adjust drive roll pressure, press gun trigger to feed wire against wood surface. Tighten knob so wire does not slip.

Cut off wire. Close door.

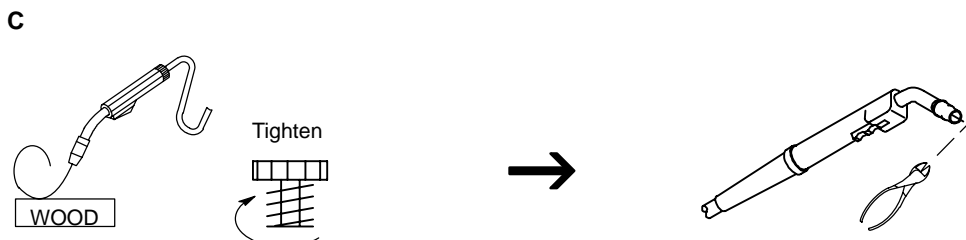
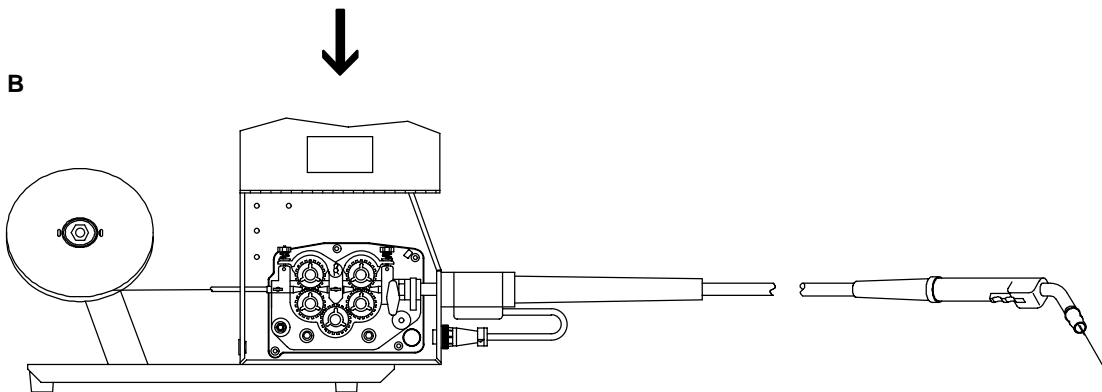
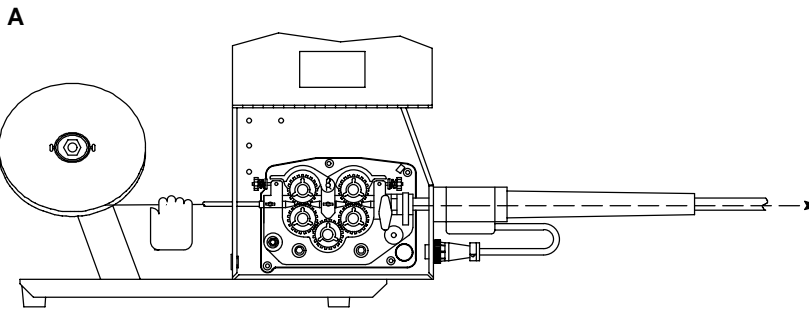

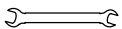
Tools Needed:
 15/16 in

Ref. 802 308 / S-0627-A

2-9. Interconnecting Power Cord Ground Lead Connection (All Models)

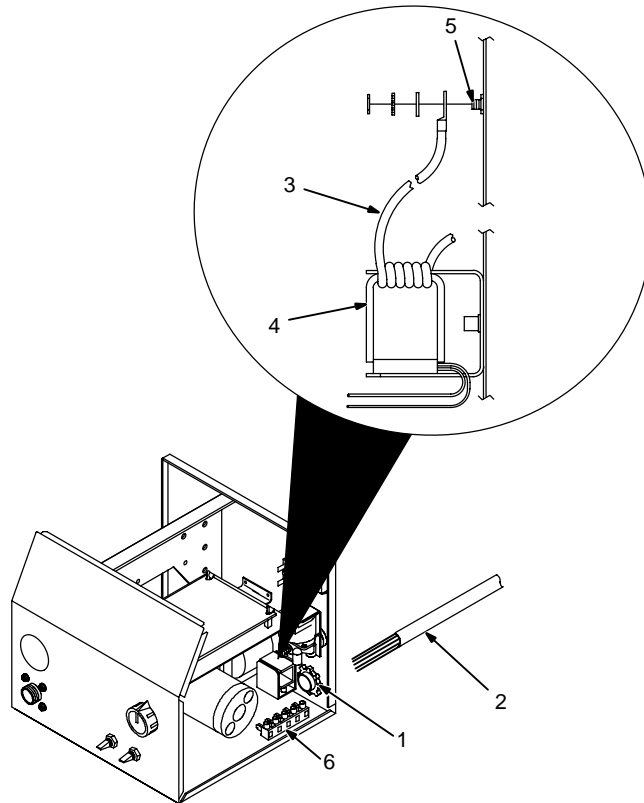

Tools Needed:

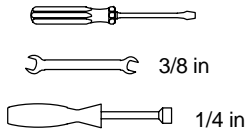

☞ The interconnecting power cord is not supplied with the unit. Be sure to obtain the proper interconnecting power cord for the welding power source the wire feeder is being connected to.

- 1 Strain Relief
- 2 Interconnecting Power Cord

☞ To ensure cord will be secure in strain relief, slide supplied tubing over cord.

Insert cord through strain relief.

☞ Ground lead must be wrapped around ground current sensor to protect ground wire against damage from weld current.

- 3 Green Lead (Ground Lead)
- 4 Ground Current Sensor
- 5 Chassis Ground Stud w/Hardware

Wrap ground lead 5 times around ground current sensor. Connect and secure end of ground lead to chassis ground stud.

- 6 Terminal Block 1T

☞ For welding power sources requiring dry contact closure, move lead 38 at terminal block to terminal D.

Refer to Sections 2-10 through 2-17 and make additional connections to terminal block 1T according to the applicable procedure.

Ref. 802 310

2-10. Connection For L-TEC Welding Power Sources With 7-Flat Socket Receptacle



☞ Make ground lead connections according to Section 2-9 before following this procedure.

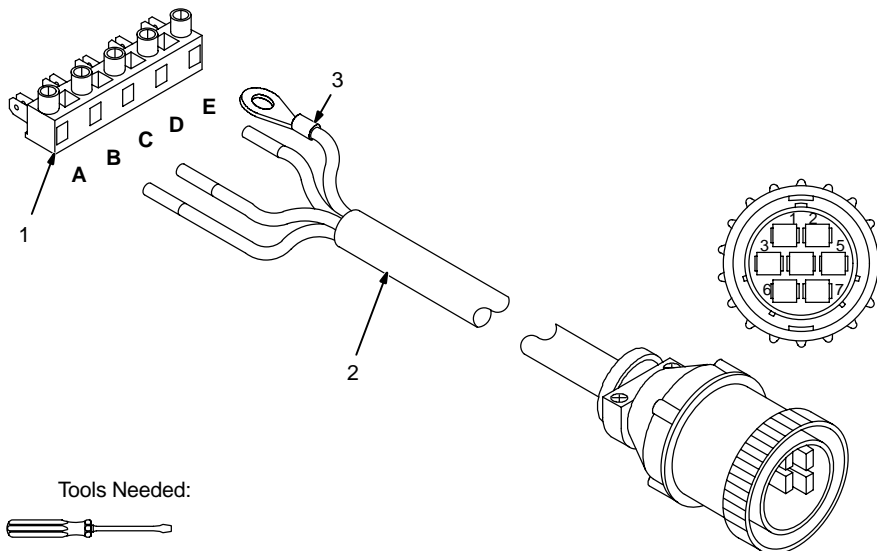

Tools Needed:

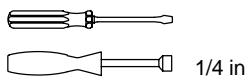

- 1 Terminal Block 1T
- 2 Interconnecting Power Cord
- 3 Green Lead (Connected To Ground In Section 2-9)

Connect remaining leads to terminal block as follows:

- A: 115 VAC/Neutral Lead
- B: 115 VAC/Hot Lead
- C: No Connection
- D: No Connection
- E: 115 VAC/Contact Closure Lead

Secure strain relief clamp around cord.

Reinstall and secure wrapper to unit.

Connect remaining end of cord to welding power source.

Ref. 802 310 / Ref. 193 749

2-11. Connection For Hobart Welding Power Sources With 19-Socket Receptacle



☞ Make ground lead connections according to Section 2-9 before following this procedure.

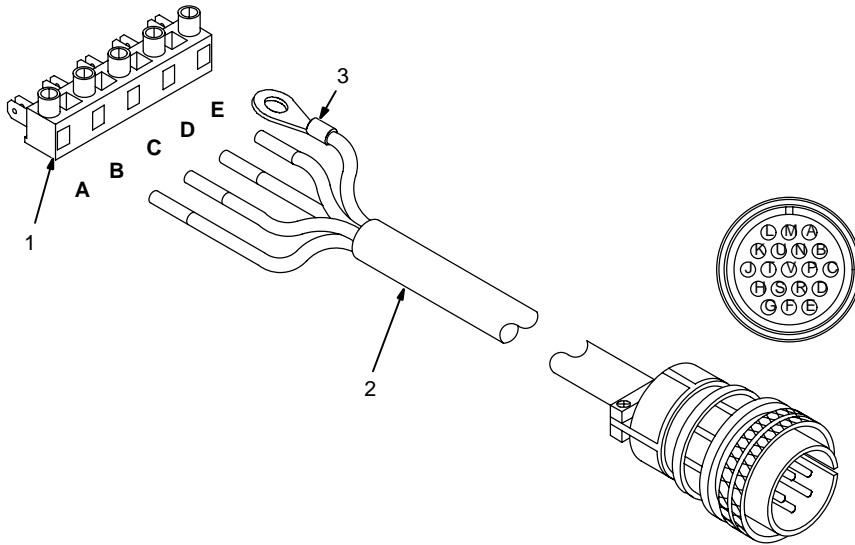

Tools Needed:

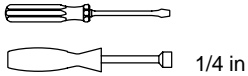

- 1 Terminal Block 1T
- 2 Interconnecting Power Cord
- 3 Green Lead (Connected To Ground In Section 2-9)

Connect remaining leads to terminal block as follows:

A: 115 VAC/Neutral Lead

B: 115 VAC/Hot Lead

C: No Connection

D: Dry Contact Closure w/Respect To Terminal E Lead

E: 115 VAC/Contact Closure Lead

☞ For welding power sources requiring dry contact closure, move lead 38 at terminal block to terminal D.

Secure strain relief clamp around cord.

Reinstall and secure wrapper to unit.

Connect remaining end of cord to welding power source.

Ref. 802 310 / Ref. 193 749

2-12. Connection For L-TEC Welding Power Sources With 19-Socket Receptacle



☞ Make ground lead connections according to Section 2-9 before following this procedure.

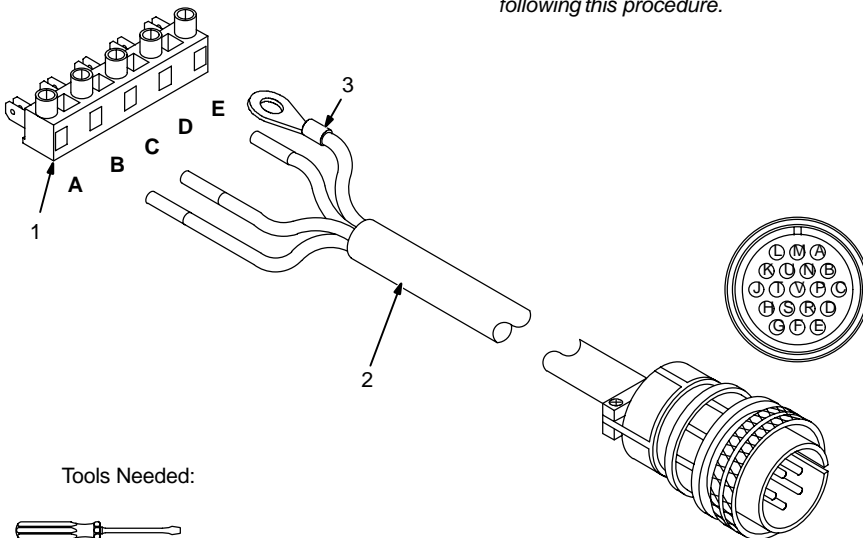

Tools Needed:

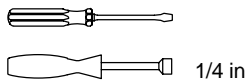

- 1 Terminal Block 1T
- 2 Interconnecting Power Cord
- 3 Green Lead (Connected To Ground In Section 2-9)

Connect remaining leads to terminal block as follows:

A: 115 VAC/Neutral Lead

B: 115 VAC/Hot Lead

C: No Connection

D: No Connection

E: 115 VAC/Contact Closure Lead

Secure strain relief clamp around cord.

Reinstall and secure wrapper to unit.

Connect remaining end of cord to welding power source.

Ref. 802 310 / Ref. 193 749

2-13. Connection For Hobart Welding Power Sources With 5-Socket And 115 Volt AC Receptacles



☞ Make ground lead connections according to Section 2-9 before following this procedure.

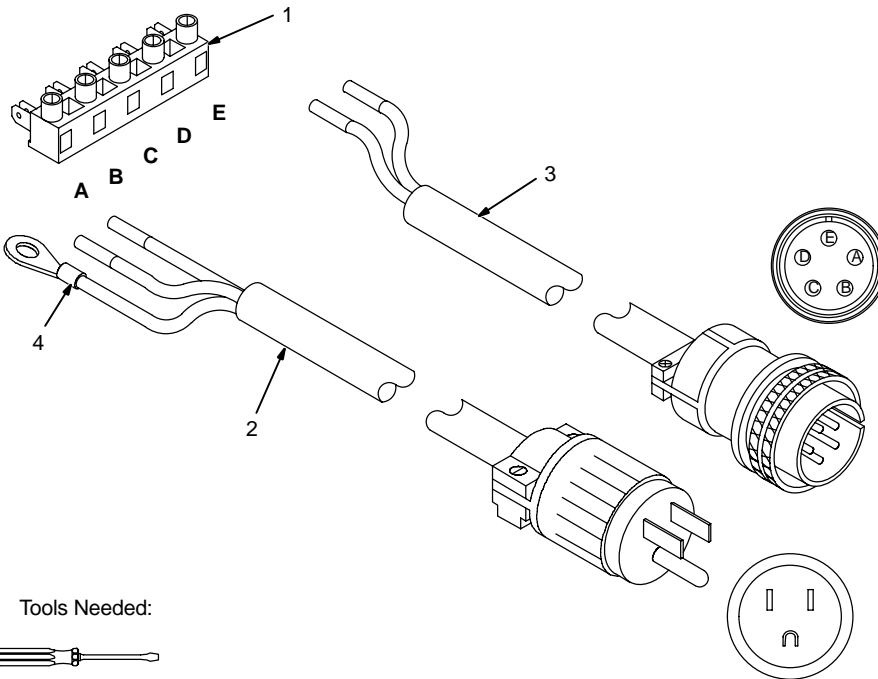

Tools Needed:

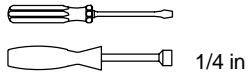

- 1 Terminal Block 1T
- 2 3-Conductor Cord
- 3 2-Conductor Cord
- 4 Green Lead (Connected To Ground In Section 2-9)

Connect remaining leads to terminal block as follows:

- A: 115 VAC/Neutral Lead
- B: 115 VAC/Hot Lead
- C: No Connection
- D: Dry Contact Closure w/Respect To Terminal E Lead
- E: 115 VAC/Contact Closure Lead

☞ For welding power sources requiring dry contact closure, move lead 38 at terminal block to terminal D.

Secure strain relief clamp around cords.

Reinstall and secure wrapper to unit.

Connect remaining cord ends to welding power source.

Ref. 802 310 / Ref. 193 749

2-14. Connection For Lincoln Welding Power Sources With 14-Socket Receptacle



☞ Make ground lead connections according to Section 2-9 before following this procedure.

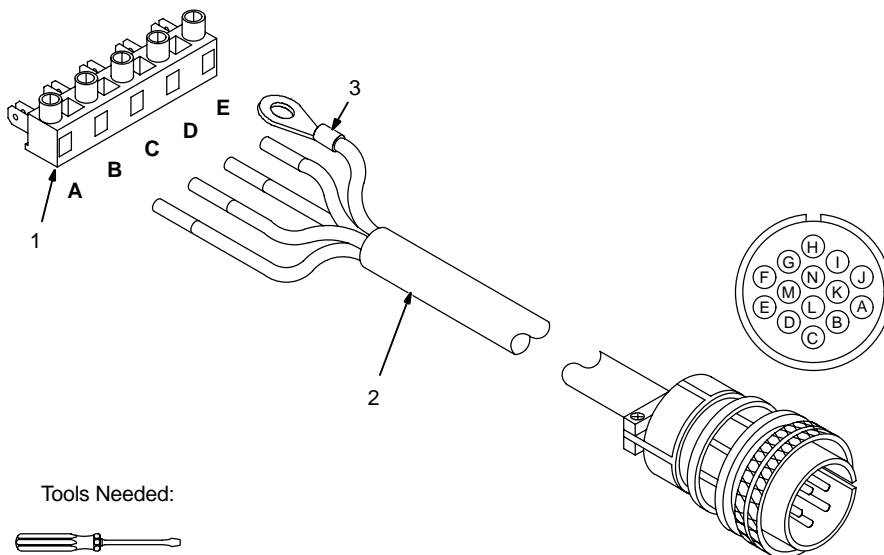

Tools Needed:

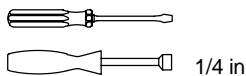

- 1 Terminal Block 1T
- 2 Interconnecting Power Cord
- 3 Green Lead (Connected To Ground In Section 2-9)

Connect remaining leads to terminal block as follows:

- A: 115 VAC/Neutral Lead
- B: 115 VAC/Hot Lead
- C: No Connection
- D: Dry Contact Closure w/Respect To Terminal E Lead
- E: 115 VAC/Contact Closure Lead

☞ For welding power sources requiring dry contact closure, move lead 38 at terminal block to terminal D.

Secure strain relief clamp around cord.

Reinstall and secure wrapper to unit.

Connect remaining end of cord to welding power source.

Ref. 802 310 / Ref. 193 749

2-15. Connection For Lincoln Welding Power Sources With Terminal Strip Connections



☞ Make ground lead connections according to Section 2-9 before following this procedure.

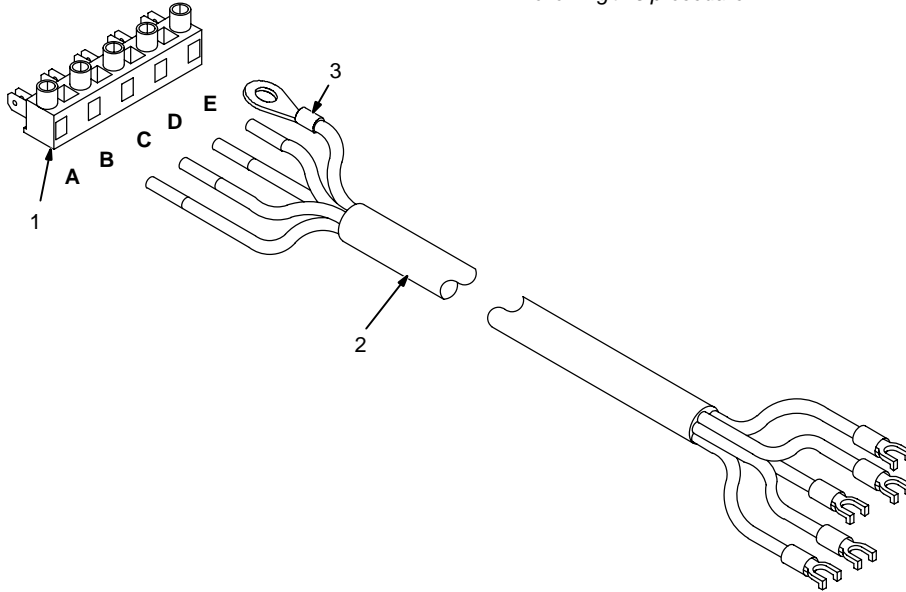

- 1 Terminal Block 1T
- 2 Interconnecting Power Cord
- 3 Green Lead (Connected To Ground In Section 2-9)

Connect remaining leads to terminal block as follows:

A: 115 VAC/Neutral Lead

B: 115 VAC/Hot Lead

C: No Connection

D: Dry Contact Closure w/Respect To Terminal E Lead

E: 115 VAC/Contact Closure Lead

☞ For welding power sources requiring dry contact closure, move lead 38 at terminal block to terminal D.

Secure strain relief clamp around cord.

Reinstall and secure wrapper to unit.

Connect remaining end of cord to welding power source.

Tools Needed:

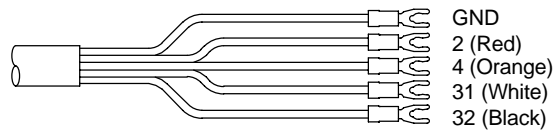
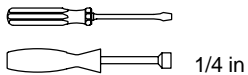

- GND
- 2 (Red)
- 4 (Orange)
- 31 (White)
- 32 (Black)

Ref. 802 310 / Ref. 193 749

2-16. Connection For AIRCO Welding Power Sources With Two-Prong Twistlock And 115 Volts AC Receptacles



☞ Make ground lead connections according to Section 2-9 before following this procedure.

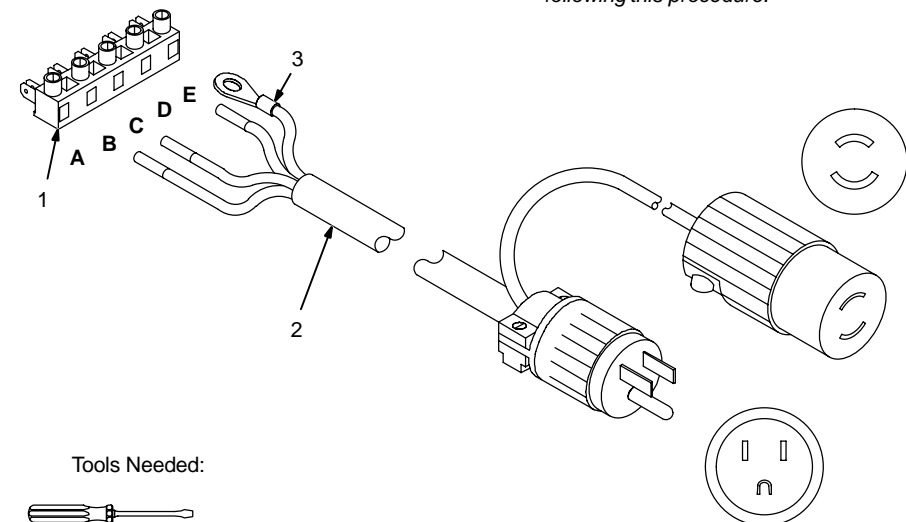

- 1 Terminal Block 1T
- 2 Interconnecting Power Cord
- 3 Green Lead (Connected To Ground In Section 2-9)

Connect remaining leads to terminal block as follows:

A: 115 VAC/Neutral Lead

B: 115 VAC/Hot Lead

C: No Connection

D: No Connection

E: 115 VAC/Contact Closure Lead

Secure strain relief clamp around cord.

Reinstall and secure wrapper to unit.

Connect remaining end of cord to welding power source.

Tools Needed:

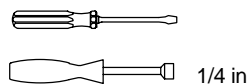

Ref. 802 310 / Ref. 193 749

2-17. Connection For Welding Power Sources With Hubbell Receptacles



☞ Make ground lead connections according to Section 2-9 before following this procedure.

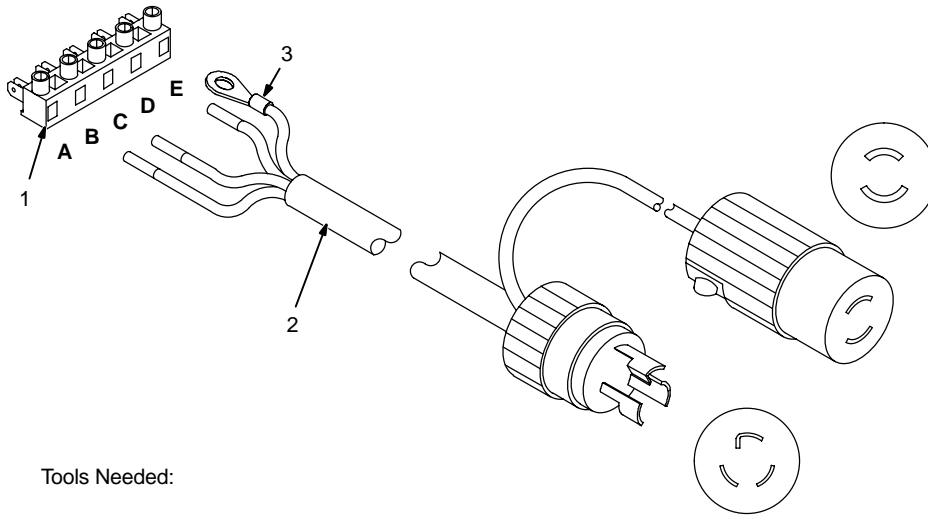

- 1 Terminal Block 1T
- 2 Interconnecting Power Cord
- 3 Green Lead (Connected To Ground In Section 2-9)

Connect remaining leads to terminal block as follows:

- A: 115 VAC/Neutral Lead
 B: 115 VAC/Hot Lead
 C: No Connection
 D: No Connection
 E: 115 VAC/Contact Closure Lead
- Secure strain relief clamp around cord.

Reinstall and secure wrapper to unit.

Connect remaining end of cord to welding power source.

Tools Needed:

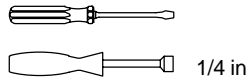

Ref. 802 310 / Ref. 193 749

2-18. Connection For Miller Welding Power Sources With 14-Socket Receptacle



☞ Make ground lead connections according to Section 2-9 before following this procedure.

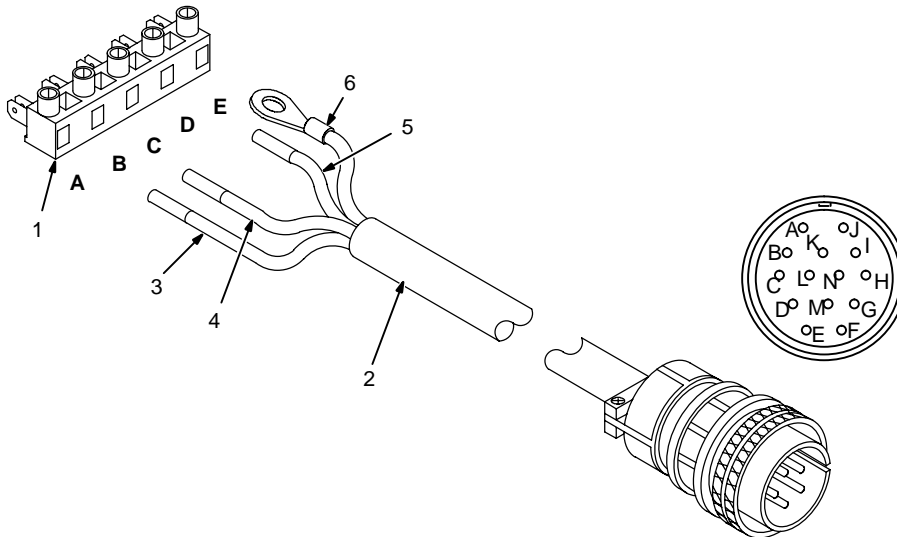

- 1 Terminal Block 1T
- 2 Interconnecting Power Cord
- 3 White Lead
- 4 Black Lead
- 5 Red Lead
- 6 Green Lead (Connected To Ground In Section 2-9)

Connect remaining leads to terminal block as follows:

- A: White Lead (115 VAC/Neutral)
 B: Black Lead (115 VAC/Hot)
 C: No Connection
 D: No Connection
 E: Red Lead (115 VAC/Contact Closure)

Secure strain relief clamp around cord.

Reinstall and secure wrapper to unit.

Connect remaining end of cord to welding power source.

Tools Needed:

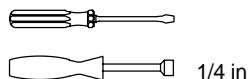

Ref. 802 310 / Ref. 193 749

2-19. Motor Start/Burnback Control

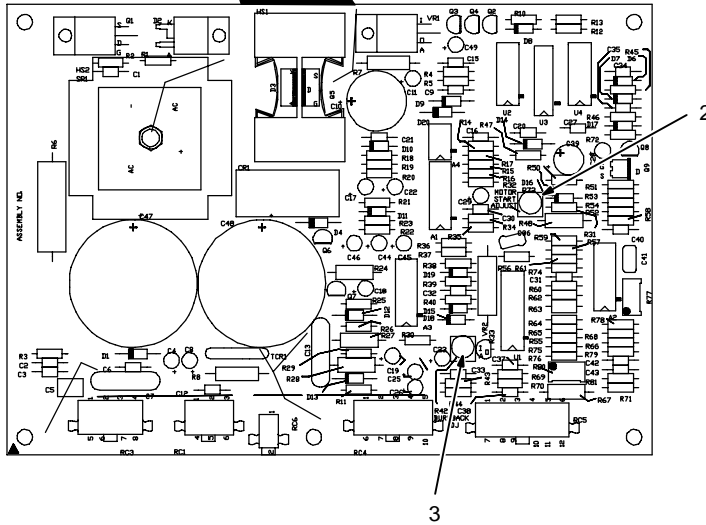
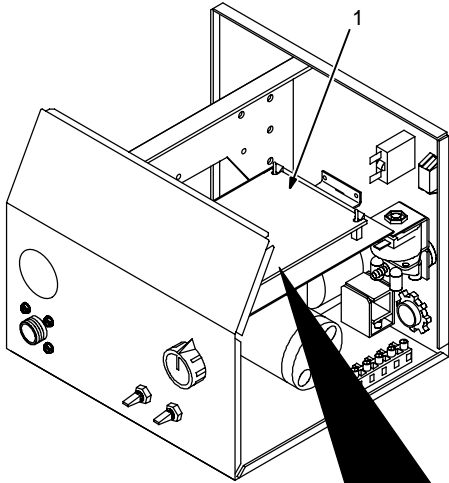

Tools Needed:

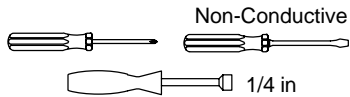

To change wire feed starting speed proceed as follows:

Turn Off unit and welding power source.

Remove wrapper.

- 1 Motor Board PC1
- 2 Motor Start Control Potentiometer R73

Remove protective white rubber cap before making adjustment. Adjust potentiometer R73 using a small nonconductive screwdriver. Rotate potentiometer clockwise to increase time it takes the motor to ramp up to speed.

- 3 Burnback Potentiometer R42

Remove protective white rubber cap before making adjustment. Adjust potentiometer R42 using a small nonconductive screwdriver. Rotate potentiometer clockwise to increase burnback time.

Reinstall wrapper.

Ref. 802 310 / 192 653

SECTION 3 – OPERATION

3-1. Front Panel Controls

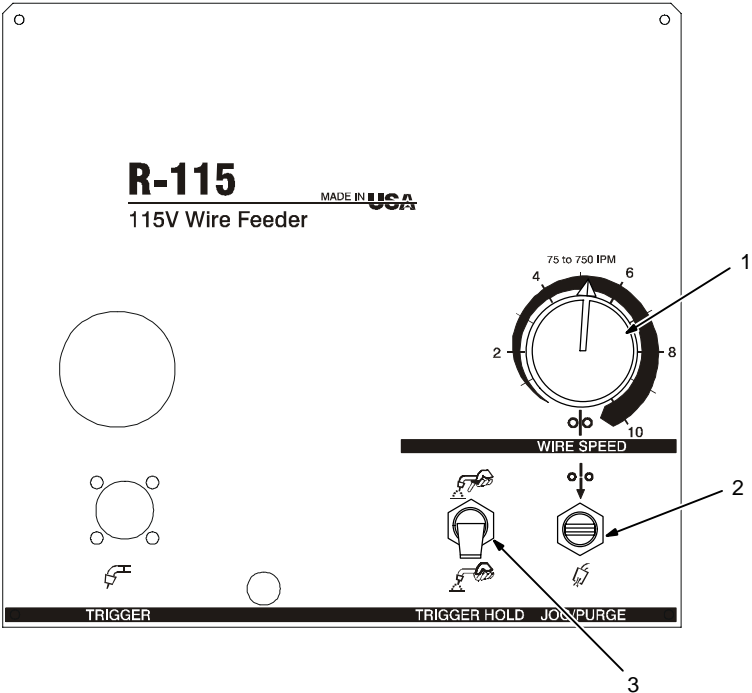

R-115
115V Wire Feeder

MADE IN **USA**

75 to 750 IPM

2 4 6 8 10

WIRE SPEED

TRIGGER TRIGGER HOLD JOG/PURGE

- 1 Wire Speed Control
- 2 Jog/Purge Switch
- 3 Trigger Hold Switch

Use Jog position to momentarily feed welding wire at speed set on Wire Speed control without energizing welding circuit or shielding gas valve.

Use Purge position to momentarily energize gas valve to purge air from gun or adjust gas regulator.

Push up to weld without holding gun trigger throughout the weld cycle.

To start weld cycle, press and release gun trigger within three seconds after an arc has been struck. To end weld, press and release gun trigger.

Power switch is on rear panel (see Section 2-5)

192 510-B

3-2. Optional Side Panel Controls

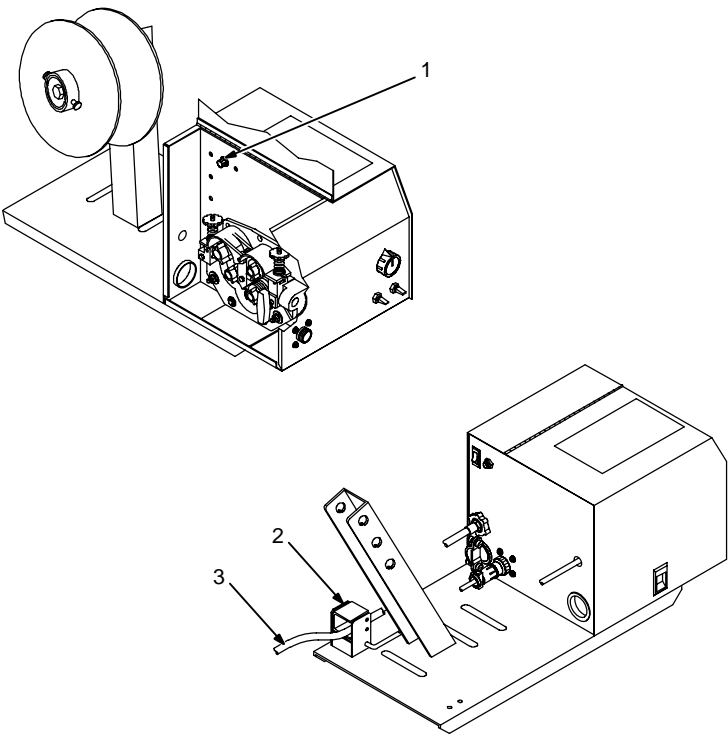

- 1 Optional Run-In Speed Control
- 2 Reed Relay Switch
- 3 Weld Cable

The Run-In Speed Control provides a means of selecting the rate at which welding wire will feed after preflow and before arc initiation. After arc initiation, the wire feed speed is governed by the Wire Speed Control. Rotating the Run-In Speed Control clockwise will increase run-in wire feed speed.









Close side door.

Weld cable must be routed through reed relay switch present on units with Run-In Speed Control option.

Ref. 802 310-A / Ref. 802 309-B

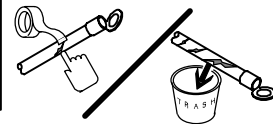
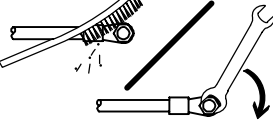
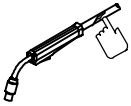
SECTION 4 – MAINTENANCE & TROUBLESHOOTING

4-1. Routine Maintenance

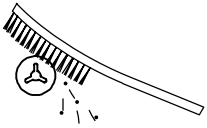
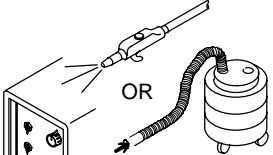
				<p>▲ Disconnect power before maintaining.</p>			
 3 Months							
							
<p>Replace Unreadable Labels</p>		<p>Repair Or Replace Cracked Weld Cable</p>		<p>Clean And Tighten Weld Terminals</p>			
						<p>Replace Cracked Parts</p>	
<p>Gun Cable</p>		<p>Gas Hose</p>					
 6 Months							
						<p>Blow Out Or Vacuum Inside, During Heavy Service, Clean Monthly</p>	
<p>Clean Drive Rolls</p>			<p>OR</p>				

4-2. Overload Protection

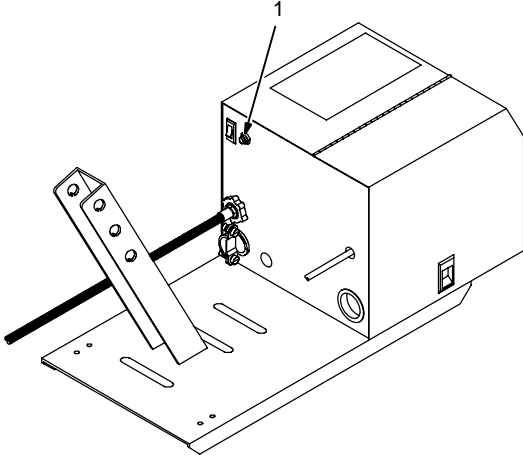
				<p>▲ Turn Off wire feeder and welding power source. Stop engine on welding generator.</p>			
				<p>1 Circuit Breaker CB1</p> <p>CB1 protects motor from overload. Correct problem and manually reset breaker.</p>			

802 309-B

4-3. Troubleshooting

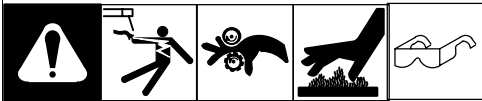
	
Trouble	Remedy
Wire does not feed, unit completely inoperative.	Turn Power switch On.
	Check circuit breaker CB1 (see Section 4-2).
	Check Interconnecting control cord connections (see Section 2-9).
	Check input power.
Wire does not feed.	Check circuit breaker CB1 (see Section 4-2).
	Check gun trigger connection at wire feeder. Check gun trigger leads and trigger switch. See gun Owner's Manual.
	Check ground current sensor (see Section 2-9).
	Check welding circuit for shorts to case activating ground current sensor.
	Have Factory Authorized Service Agent check drive motor and control board PC1.
Wire feeds erratically.	Readjust hub tension and drive roll pressure (see Section 2-8).
	Use correct size drive roll (see Parts List).
	Clean or replace dirty or worn drive roll (see Section 2-7).
	Remove weld spatter around nozzle opening.
	Replace contact tip or liner. See gun Owner's Manual.
	Have Factory Authorized Service Agent check drive motor and control board PC1.
Wire feeds when Jog switch is pressed but not when gun trigger is pressed.	Check gun trigger connection at wire feeder. Check gun trigger leads and trigger switch. See gun Owner's Manual.
Wire feeds as soon as power is applied.	Check gun trigger. See gun Owner's Manual.
Wire does not feed until trigger is pressed but continues to feed after trigger is released.	Check for short between gun trigger leads and weld cable. Repair or replace gun trigger leads.
Gas does not flow; wire feeds.	Check gas valve and flowmeter.

SECTION 5 – ELECTRICAL DIAGRAM

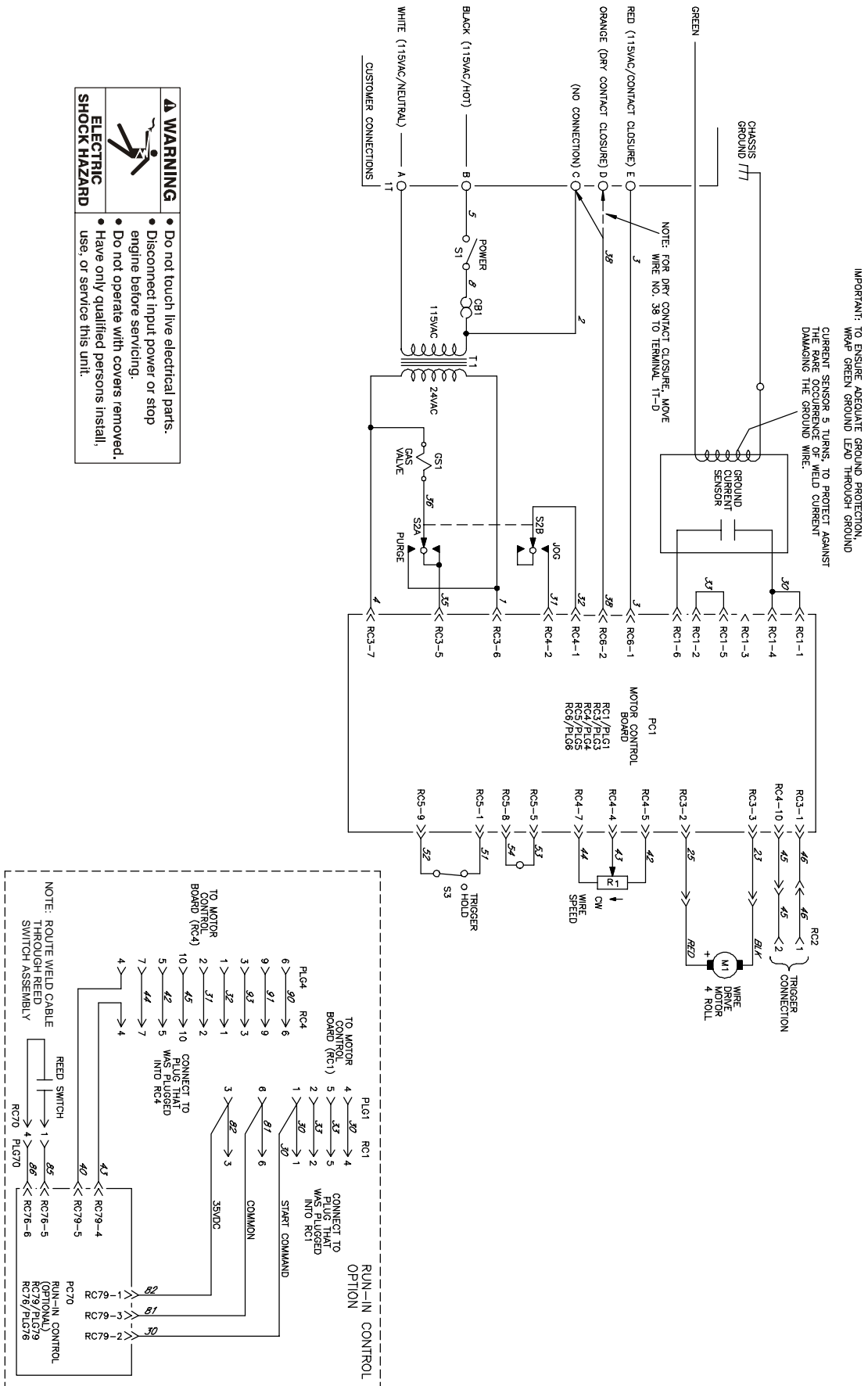
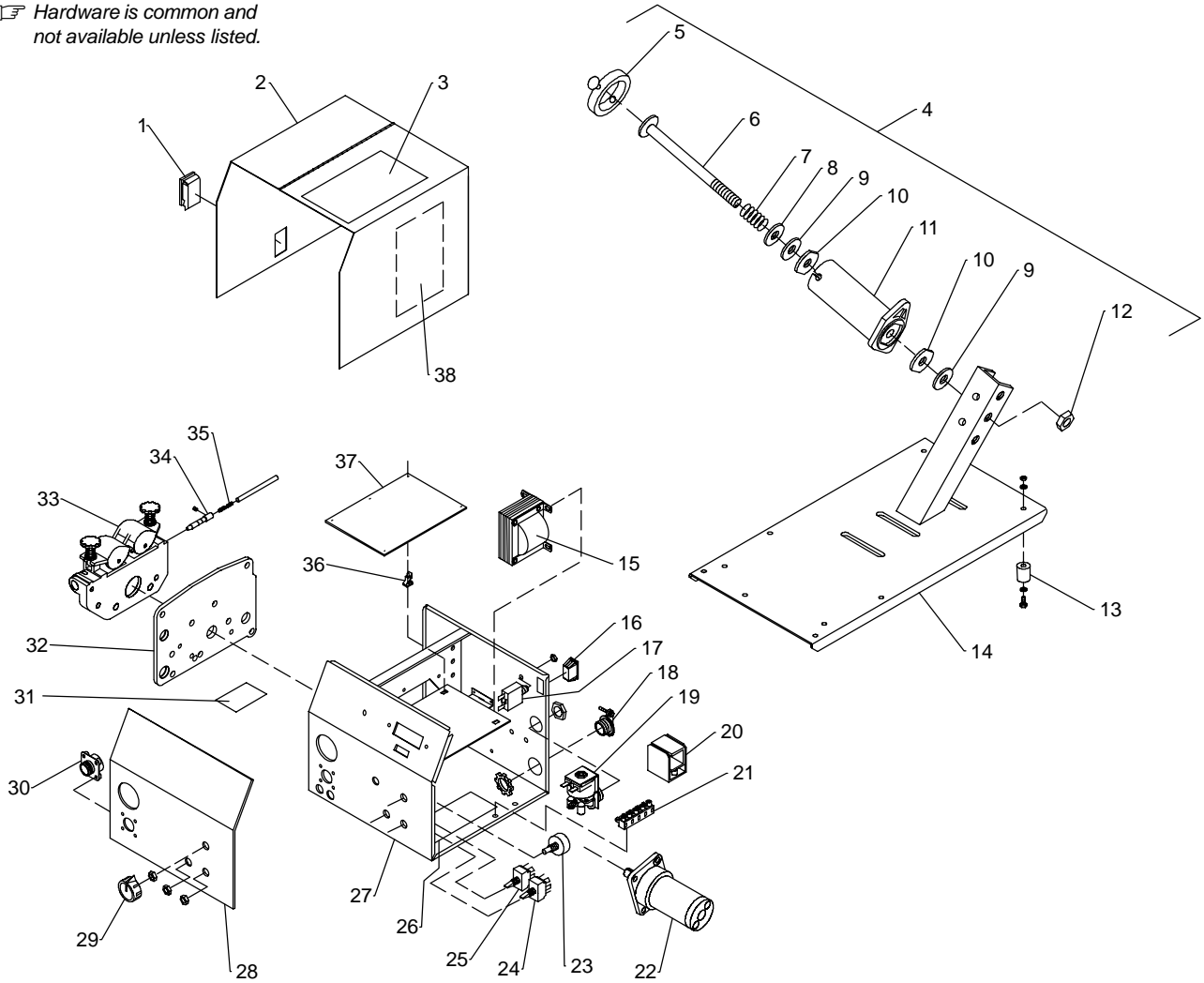

Figure 5-1. Circuit Diagram For Wire Feeder With Optional Equipment

SECTION 6 – PARTS LIST

☞ Hardware is common and not available unless listed.



802 305-B

Figure 6-1. Main Assembly

Item No.	Dia. Mkgs.	Part No.	Description	Quantity
----------	------------	----------	-------------	----------

Figure 6-1. Main Assembly

...	1	089 899	LATCH	1
...	2	+198 651	WRAPPER	1
...		126 873	BUMPER	1
...	3	134 464	LABEL, warning electric shock	1
...	4	072 094	HUB & SPINDLE ASSEMBLY, (consisting of)	1
...	5	058 427	RING, retaining spool	1
...	6	180 572	SHAFT, spool support	1
...	7	010 233	SPRING, cprsn .970 OD x .120 wire x 1.250	1
...	8	057 971	WASHER, flat stl keyed 1.500dia x .125thk	1
...	9	010 191	WASHER, fbr .656 ID x 1.500 OD x .125thk	2
...	10	058 628	WASHER, brake stl	2
...	11	058 428	HUB, spool	1
...	12	135 205	NUT, stl sflkg hex reg .625-11 w/nylon insert	1
...	13	134 306	FOOT, rbr 1.250dia x 1.375 high	4
...	14	137 461	BASE	1
...	T1	193 351	TRANSFORMER, control 115/24VAC	1
...	S1	111 997	SWITCH, rocker SPST 10A 250VAC	1
...	CB1	011 244	CIRCUIT BREAKER, man reset 1P 2A 250VAC	1

Item No.	Dia. Mkgs.	Part No.	Description	Quantity
Figure 6-1. Main Assembly (Continued)				
18		044 426	CONNECTOR, clamp cable	1
19	GS1	125 785	VALVE, 24VAC 2 way custom port 1/8 orf	1
20	GFI	193 440	SWITCH, ground current sensor	1
21	1T	193 376	BLOCK, terminal 20A 5 pole	1
		193 500	LABEL, terminal mkg 20A 5 pole	1
22	M1	193 188	MOTOR, gear 24VDC 146RPM (consisting of)	1
		*136 745	BRUSH & SPRING ASSEMBLY	2
23	R1	073 562	POTENTIOMETER, C sltd sft1/T 2W 10K ohm	1
24	S2	134 846	SWITCH, tgl SPTT 6A 125VAC	1
25	S3	134 847	SWITCH, tgl SPDT 15A 125VAC	1
		189 404	SPACER, nylon	2
26		194 401	LABEL, warning ground current	1
27		197 328	CASE ASSY	1
28			NAMEPLATE (order by model and serial number)	1
	RC2	191 239	CONNECTOR, w/leads	1
29		097 924	KNOB, pointer	1
30		048 282	CONNECTOR & SOCKETS	1
31		178 937	LABEL, warning electric shock and pinch	1
32		192 875	INSULATOR, drive motor	1
33		Fig 6-2	WIRE DRIVE ASSEMBLY	1
34		188 149	GUIDE, wire inlet .030 thru 5/64 in dia (consisting of)	1
35		082 050	LINER, monocoil inlet wire	1
		082 036	GUIDE, wire inlet	1
34		◆194 264	GUIDE, wire inlet 3/32 in dia (consisting of)	1
35		082 050	LINER, monocoil inlet wire	1
		194 265	GUIDE, wire inlet	1
	PLG4	115 091	HOUSING PLUG & SKTS	1
	PLG3	115 092	HOUSING PLUG & SKTS	1
	PLG6	131 054	HOUSING RCPT & SKTS	1
		120 304	BLANK, snap-in nyl .250 mtg hole	4
		107 983	BLANK, snap-in nyl .500 mtg hole	2
		024 103	BLANK, snap-in nyl .750 mtg hole	2
		000 527	BLANK, snap-in nyl .875 mtg hole	1
		010 494	BUSHING, snap-in nyl 1.375 ID x 1.750 mtg hole	1
36		134 201	STAND-OFF SUPPORT, PC card	5
37	PC1	192 652	CIRCUIT CARD ASSY, motor	1
38		194 362	LABEL, warning ground	1
	PC70	◆196 746	CIRCUIT CARD ASSY	1
		◆194 310	BRACKET, mounting	1
		◆097 132	STAND-OFF, 6-32 x .375 lg .250 hex	2
		◆093 551	KNOB	1
		◆140 789	SWITCH, reed	1
		◆193 917	LABEL, indicator run-in	1
		◆193 719	BRACKET, mounting receptacle	1
		◆115 093	HOUSING PLUG & SOCKETS	1
		◆131 059	HOUSING PLUG & SOCKETS	1
		◆115 091	HOUSING PLUG & SOCKETS	1
		◆135 531	HOUSING PLUG & SOCKETS	1
		◆048 282	HOUSING PLUG & SOCKETS	1

+When ordering a component originally displaying a precautionary label, the label should also be ordered.

◆OPTIONAL

To maintain the factory original performance of your equipment, use only Manufacturer's Suggested Replacement Parts. Model and serial number required when ordering parts from your local distributor.

Item No.	Dia. Mkgs.	Part No.	Description	Quantity
----------	------------	----------	-------------	----------

Figure 6-2. Drive Assembly, Wire (Fig 7-2 Item 1)

1		602 009	SCREW, .250-20 x 1.250 soc hd hex gr 8	4
2		172 075	CARRIER, drive roll w/component 24 pitch	4
3		166 072	SPACER, gear	4
4		054 263	SCREW, thumb stl .250-20 x .500	2
5		010 224	PIN, spring CS .187 x 1.000	2
6		089 562	FASTENER, pinned	2
7		085 244	WASHER, cupped stl .328 ID x .812 OD x .125	2
8		089 477	SPRING, cprsn .770 OD x .105 wire x 1.225	2
9		085 243	KNOB, adjustment tension	2
10		166 071	LEVER, mtg pressure gear	1
11		079 634	PIN, hinge	1
12		151 828	PIN, cotter hair .054 x .750	2
13		166 338	LEVER, mtg pressure gear	1
14		605 308	RING, rtng ext .500 shaft	1
15		187 325	INSULATOR, drive assembly	1
16		144 172	FITTING, hose brs barbed m 3/16 tbg x .250-20	1
17		166 337	HOUSING, adapter gun/feeder	1
18		072 010	WASHER, shldr .316 ID x .812 OD x .187thk	2
19		168 590	BUSHING, insulating	2
20		124 778	KNOB, T 2.000 bar w/.312-18 x 1.000lg	1
21		079 625	WASHER, wave .500 ID x .750 OD x .015thk	2
22		092 865	KEY, stl	1
23		172 077	CARRIER, drive roll keyed 24 pitch	1
24		121 271	SCREW, .250-20 x .500 soc hd	1

 Hardware is common and not available unless listed.

See Table 6-1 For Drive Roll & Wire Guide Kits

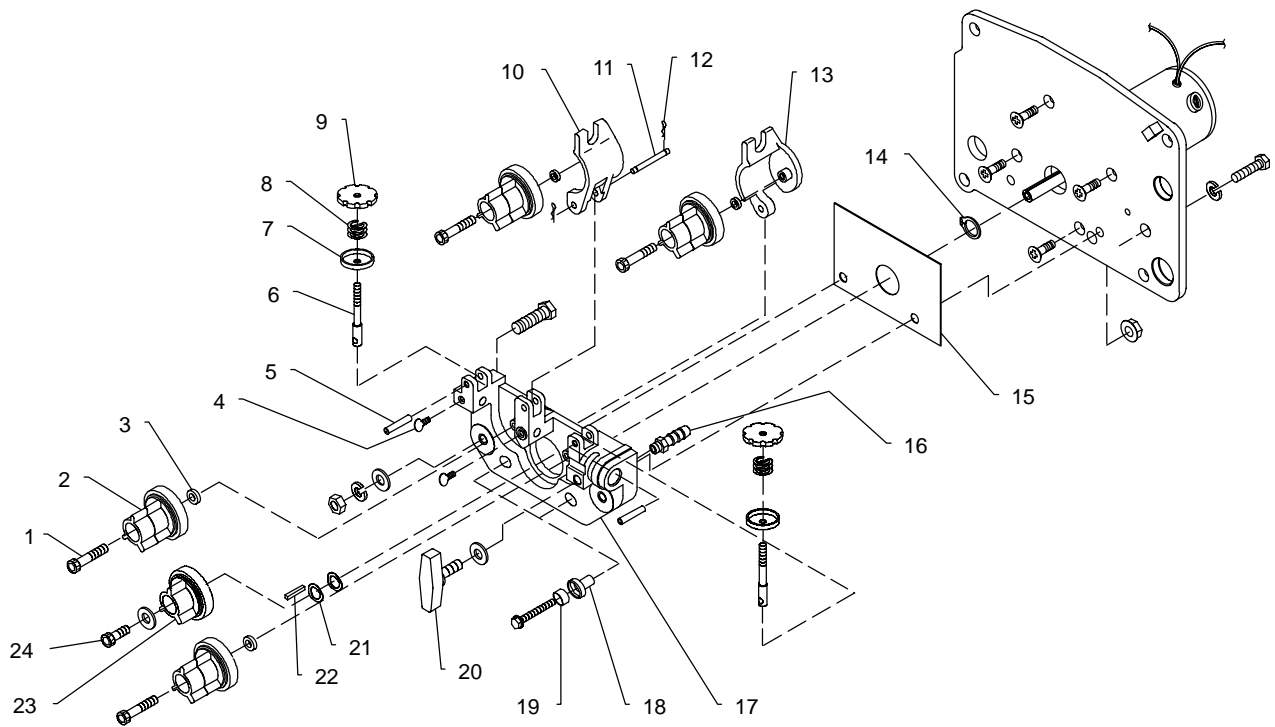

802 307-A

Figure 6-2. Drive Assembly, Wire

To maintain the factory original performance of your equipment, use only Manufacturer's Suggested Replacement Parts. Model and serial number required when ordering parts from your local distributor.

Table 6-1. Drive Roll & Wire Guide Kits

NOTE



Base selection of drive rolls upon the following recommended usages:

1. V-Grooved rolls for hard wire.
2. U-Grooved rolls for soft and soft shelled cored wires.
3. U-Cogged rolls for extremely soft shelled wires (usually hard surfacing types).
4. V-Knurled rolls for hard shelled cored wires.
5. Drive roll types may be mixed to suit particular requirements (example: V-Knurled roll in combination with U-Grooved).

Wire Diameter			Kit No.	Drive Roll		Wire Guide	
Fraction	Decimal	Metric		Part No.	Type	Inlet	Intermediate
.023/.025 in	.023/.025 in	0.6 mm	087 132	087 130	V-Grooved	056 192	056 206
.030 in	.030 in	0.8 mm	046 780	053 695	V-Grooved	056 192	056 206
.035 in	.035 in	0.9 mm	046 781	053 700	V-Grooved	056 192	056 206
.040 in	.040 in	1.0 mm	191 917	053 696	V-Grooved	056 192	056 206
.045 in	.045 in	1.2 mm	046 782	053 697	V-Grooved	056 193	056 207
.052 in	.052 in	1.3 mm	046 783	053 698	V-Grooved	056 193	056 207
1/16 in	.062 in	1.6 mm	046 784	053 699	V-Grooved	056 195	056 209
.035 in	.035 in	0.9 mm	044 750	072 000	U-Grooved	056 192	056 206
.045 in	.045 in	1.2 mm	046 785	053 701	U-Grooved	056 193	056 207
.052 in	.052 in	1.3 mm	046 786	053 702	U-Grooved	056 193	056 207
1/16 in	.062 in	1.6 mm	046 787	053 706	U-Grooved	056 195	056 209
5/64 in	.079 in	2.0 mm	046 788	053 704	U-Grooved	056 195	056 209
3/32 in	.094 in	2.4 mm	046 789	053 703	U-Grooved	056 196	056 210
.035 in	.035 in	0.9 mm	046 792	132 958	V-Knurled	056 192	056 206
.045 in	.045 in	1.2 mm	046 793	132 957	V-Knurled	056 193	056 207
.052 in	.052 in	1.3 mm	046 794	132 956	V-Knurled	056 193	056 207
1/16 in	.062 in	1.6 mm	046 795	132 955	V-Knurled	056 195	056 209
.068-.072 in	.068-.072 in	1.8 mm	089 985	132 959	V-Knurled	056 195	056 209
5/64 in	.079 in	2.0 mm	046 796	132 960	V-Knurled	056 195	056 209
3/32 in	.094 in	2.4 mm	046 797	132 961	V-Knurled	056 196	056 210
.045 in	.045 in	1.2 mm	083 319	083 489	U-Cogged	056 193	056 207
.052 in	.052 in	1.3 mm	083 320	083 490	U-Cogged	056 193	056 207
1/16 in	.062 in	1.6 mm	046 800	053 708	U-Cogged	056 195	056 209
5/64 in	.079 in	2.0 mm	046 801	053 710	U-Cogged	056 195	056 209
3/32 in	.094 in	2.4 mm	046 802	053 709	U-Cogged	056 196	056 210

Ref. S-0025-D

HOBART WARRANTY

Effective January 1, 2000

(Equipment with a serial number preface of "LA" or newer)

This limited warranty supersedes all previous Hobart warranties and is exclusive with no other guarantees or warranties expressed or implied.

Warranty Questions?

Call

1-877-HOBART1

for your local
Hobart distributor.

Service

You always get the fast, reliable response you need. Most replacement parts can be in your hands in 24 hours.

Support

Need fast answers to the tough welding questions? Contact your distributor or call 1-800-332-3281. The expertise of the distributor and Hobart is there to help you, every step of the way.

LIMITED WARRANTY – Subject to the terms and conditions below, Hobart Welding Products., Troy, Ohio, warrants to its original retail purchaser that new Hobart equipment sold after the effective date of this limited warranty is free of defects in material and workmanship at the time it is shipped by Hobart. THIS WARRANTY IS EXPRESSLY IN LIEU OF ALL OTHER WARRANTIES, EXPRESS OR IMPLIED, INCLUDING THE WARRANTIES OF MERCHANTABILITY AND FITNESS.

Within the warranty periods listed below, Hobart will repair or replace any warranted parts or components that fail due to such defects in material or workmanship. Hobart must be notified in writing within thirty (30) days of such defect or failure, at which time Hobart will provide instructions on the warranty claim procedures to be followed.

Hobart shall honor warranty claims on warranted equipment listed below in the event of such a failure within the warranty time periods. All warranty time periods start on the date that the equipment was delivered to the original retail purchaser, or one year after the equipment is sent to a North American distributor or eighteen months after the equipment is sent to an International distributor.

1. 5 Years Parts – 3 Years Labor
 - * Original main power rectifiers
 - * Inverters (input and output rectifiers only)
2. 3 Years — Parts and Labor
 - * Transformer/Rectifier Power Sources
 - * Plasma Arc Cutting Power Sources
 - * Semi-Automatic and Automatic Wire Feeders
 - * Inverter Power Supplies
 - * Intelligig
 - * Engine Driven Welding Generators
(NOTE: Engines are warranted separately by the engine manufacturer.)
3. 1 Year — Parts and Labor
 - * DS-2 Wire Feeder
 - * Motor Driven Guns (w/exception of Spoolmate 185 & Spoolmate 250)
 - * Process Controllers
 - * Positioners and Controllers
 - * Automatic Motion Devices
 - * RFCS Foot Controls
 - * Induction Heating Power Sources
 - * Water Coolant Systems
 - * HF Units
 - * Grids
 - * Maxstar 140
 - * Spot Welders
 - * Load Banks
 - * Hobart Cyclomatic Equipment
 - * Running Gear/Trailers
 - * Plasma Cutting Torches (except APT & SAF Models)
 - * Field Options
(NOTE: Field options are covered under True Blue® for the remaining warranty period of the product they are installed in, or for a minimum of one year — whichever is greater.)
4. 6 Months — Batteries
5. 90 Days — Parts
 - * MIG Guns/TIG Torches
 - * Induction Heating Coils and Blankets

- * APT, ZIPCUT & PLAZCUT Model Plasma Cutting Torches
- * Remote Controls
- * Accessory Kits
- * Replacement Parts (No labor)
- * Spoolmate 185 & Spoolmate 250
- * Canvas Covers

HOBART's Limited Warranty shall not apply to:

1. **Consumable components; such as contact tips, cutting nozzles, contactors, brushes, slip rings, relays or parts that fail due to normal wear.**
2. Items furnished by Hobart, but manufactured by others, such as engines or trade accessories. These items are covered by the manufacturer's warranty, if any.
3. Equipment that has been modified by any party other than Hobart, or equipment that has been improperly installed, improperly operated or misused based upon industry standards, or equipment which has not had reasonable and necessary maintenance, or equipment which has been used for operation outside of the specifications for the equipment.

HOBART PRODUCTS ARE INTENDED FOR PURCHASE AND USE BY COMMERCIAL/INDUSTRIAL USERS AND PERSONS TRAINED AND EXPERIENCED IN THE USE AND MAINTENANCE OF WELDING EQUIPMENT.

In the event of a warranty claim covered by this warranty, the exclusive remedies shall be, at Hobart's option: (1) repair; or (2) replacement; or, where authorized in writing by Hobart in appropriate cases, (3) the reasonable cost of repair or replacement at an authorized Hobart service station; or (4) payment of or credit for the purchase price (less reasonable depreciation based upon actual use) upon return of the goods at customer's risk and expense. Hobart's option of repair or replacement will be F.O.B., Factory at Appleton, Wisconsin, or F.O.B. at a Hobart authorized service facility as determined by Hobart. Therefore no compensation or reimbursement for transportation costs of any kind will be allowed.

TO THE EXTENT PERMITTED BY LAW, THE REMEDIES PROVIDED HEREIN ARE THE SOLE AND EXCLUSIVE REMEDIES. IN NO EVENT SHALL HOBART BE LIABLE FOR DIRECT, INDIRECT, SPECIAL, INCIDENTAL OR CONSEQUENTIAL DAMAGES (INCLUDING LOSS OF PROFIT), WHETHER BASED ON CONTRACT, TORT OR ANY OTHER LEGAL THEORY.

ANY EXPRESS WARRANTY NOT PROVIDED HEREIN AND ANY IMPLIED WARRANTY, GUARANTY OR REPRESENTATION AS TO PERFORMANCE, AND ANY REMEDY FOR BREACH OF CONTRACT TORT OR ANY OTHER LEGAL THEORY WHICH, BUT FOR THIS PROVISION, MIGHT ARISE BY IMPLICATION, OPERATION OF LAW, CUSTOM OF TRADE OR COURSE OF DEALING, INCLUDING ANY IMPLIED WARRANTY OF MERCHANTABILITY OR FITNESS FOR PARTICULAR PURPOSE, WITH RESPECT TO ANY AND ALL EQUIPMENT FURNISHED BY HOBART IS EXCLUDED AND DISCLAIMED BY HOBART.

Some states in the U.S.A. do not allow limitations of how long an implied warranty lasts, or the exclusion of incidental, indirect, special or consequential damages, so the above limitation or exclusion may not apply to you. This warranty provides specific legal rights, and other rights may be available, but may vary from state to state.

In Canada, legislation in some provinces provides for certain additional warranties or remedies other than as stated herein, and to the extent that they may not be waived, the limitations and exclusions set out above may not apply. This Limited Warranty provides specific legal rights, and other rights may be available, but may vary from province to province.





Owner's Record

Please complete and retain with your personal records.

Model Name

Serial/Style Number

Purchase Date

(Date which equipment was delivered to original customer.)

Distributor

Address

City

State

Zip



Resources Available

Always provide Model Name and Serial/Style Number.

To locate a Distributor, retail or service location:

Call 1-877-Hobart1 or visit our website at www.HobartWelders.com

For technical assistance:

Call 1-800-332-3281

Contact your Distributor for:

Welding Supplies and Consumables

Options and Accessories

Personal Safety Equipment

Service and Repair

Replacement Parts

Training (Schools, Videos, Books)

Technical Manuals (Servicing Information and Parts)

Circuit Diagrams

Welding Process Handbooks

Contact the Delivering Carrier for:

For assistance in filing or settling claims, contact your distributor and/or equipment manufacturer's Transportation Department.

File a claim for loss or damage during shipment.

Hobart Welding Products

An Illinois Tool Works Company
600 West Main Street
Troy, OH 45373 USA

For Technical Assistance:

Call 1-800-332-3281
For Literature Or Nearest Dealer:
Call 1-877-Hobart1