OWNER'S MANUAL

MOTORIZED TROLLEY MR2 SERIES

1 Ton through 20 Ton Capacity

Code, Lot and Serial Number

WARNING

This equipment should not be installed, operated or maintained by any person who has not read and understood all the contents of this manual. Failure to read and comply with the contents of this manual can result in serious bodily injury or death, and/or property damage.

HARRINGTON
HOISTS AND CRANES

9.0 Parts List

When ordering parts, please provide the trolley code number, lot number and serial number located on the hoist name Plate (see fig. below).

Reminder: Per sections 1.1 and 3.6.1 to aid in ordering parts and product Support, record the trolley code number, lot number and serial number in the space provided on the Cover of this manual.



The parts list is arranged into the following sections:

Section 1/8 to 5 Ton	Page
9.1 Electric Parts – 1/8 to 5 Ton.....	52
9.2 Pendant Parts – 1/8 to 5 Ton	58
9.3 Power Supply Parts – 1/8 to 5 Ton	60
9.4 Side Plates and Suspension Parts – 1/8 to 5 Ton	62
9.5 Motor Parts – 1/8 to 5 Ton	64
 Section 8 to 20 Ton	
9.6 Motor Parts – 8 to 20 Ton	66
9.7 Side Plates and Suspension Parts – 8 to 20 Ton	68
9.8 Electric Parts – 1/8 to 20 Ton	70
9.9 Pendant Parts – 8 to 20 Ton	72
9.10 Optional Parts – 8 Ton	74

In the column "Parts Per Trolley" a designator is used for parts that apply only to a particular model or option. Refer to Section 2 for MR2 Trolley model numbers and additional descriptions.

The designators are:

S = Single Speed	W = SS/SS = Single Speed Hoist, Single Speed Trolley
D = Dual Speed	X = SS/DS = Single Speed Hoist, Dual Speed Trolley
PC = Plug Connection	Y = DS/SS = Dual Speed Hoist, Single Speed Trolley
DC = Direct Connection	Z = DS/DS = Dual Speed Hoist, Dual Speed Trolley
2V = 208/230 Volt Models	4V = 460 Volt Models

9.1 Electric Parts – 1/8 to 5 Ton (Single Speed)

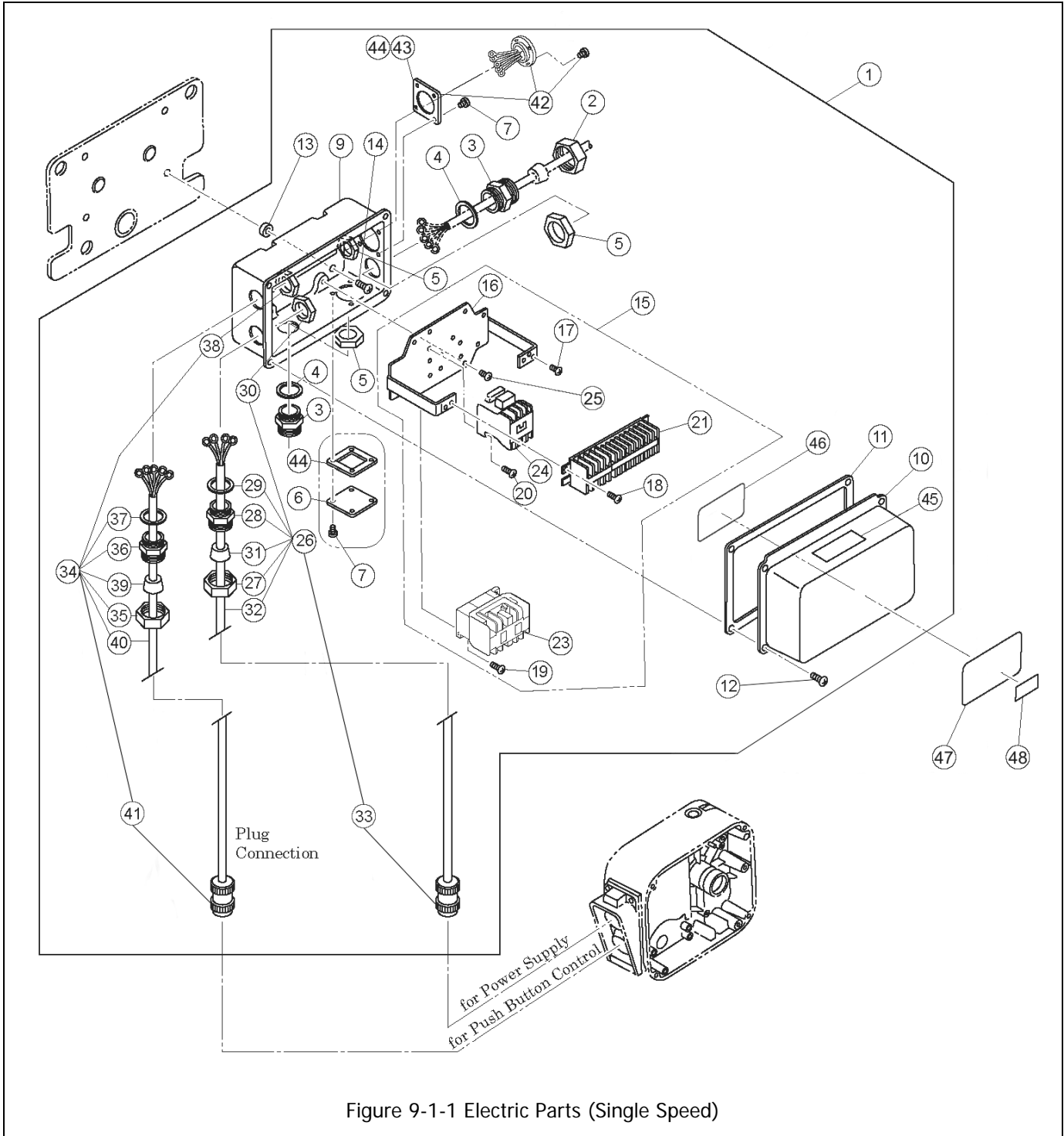

9.1 Electric Parts– 1/8 to 5 Ton (Single Speed)

Figure No.	Part Name	Parts Per Trolley	1 Ton	2 Ton	3 Ton	5 Ton
1	Connection Box Assembly	1	7013001	7013002		
2	Holder A	1	ECP5924AA			
3	Holder B	2	ECP5924AB			
4	Packing	2	ECP5924AC			
5	Holder Nut	2	ECP5924AD			
6	Cord Cover	1	E6F630010S			
7	Machine Screw With Spring Washer	8	MS554010			
9	Connection Box	1	MR1DS9401			
10	Connection Box Cover	1	MR1DS9411			
11	Connection Box Packing	1	MR1DS9421			
12	Machine Screw With Spring Washer	4	MS554010			
13	Spacer	4	MS517010			
14	Machine Screw With Spring Washer	4	MS551010			
15	Complete Plate Assembly	1	MR2RHM10M1A5			
16	Plate	1	MR2DS5445			
17	Machine Screw With Spring Washer	3	MS555010			
18	Machine Screw With Spring Washer	2	MS556010			
19	Machine Screw With Spring Washer	2	MS556010			
20	Machine Screw With Spring Washer	2	MS556010			
21	Terminal 16P	1	ECP1416AA			
23	Electromagnetic Contactor	1	MGC22306B			
24	E-Stop Contactor	1	MGC12306B			
25	Machine Screw With Spring Washer	4	MS554010			
26	Power Supply Cable Assembly	1	MR2DS1759	MR2ES1759		
27	Holder A	1	ECP5924AA			
28	Holder B	1	ECP5924AB			
29	Packing	1	ECP5924AC			
30	Holder Nut	1	ECP5924AD			
31	Cable Packing	1	ECP6912AA	ECP6916AA		
32	S.O. Cord 4C	1	16/4	14/4		
33	Plug 4P	1	ECP2304AD	ECP2304AF		
34	Control Cable Assembly	1	MR2DS1768	MR2ES1768		
35	Holder A	1	ECP5924AA			
36	Holder B	1	ECP5924AB			
37	Packing	1	ECP5924AC			
38	Holder Nut	1	ECP5924AD			
39	Cable Packing	1	ECP6916AA			
40	S.O. Cord 6C	1	16/6P			
41	Plug 8P	1	ECP2108AC			
42	Socket 8P Assembly	1	MR2DS2811			
43	Plate P	1	ECP5924AH			
44	Cord Cover Packing	2	MS527010			
45	Warning Seal E (Electric Shock)	1	ER2CS9936			
46	Wiring Diagram	1	EWG3110H01			
47	Name Plate B	1	MR2SHM10S9A8			
48	Name Plate C	1	MR2SHM10S9A7	MR2SHM20S9A7	MR2SHM30S9A7	MR2SHM50S9A7

Name Plates for 1/8, 1/4, 1/2, 1 1/2 & 2 1/2 Ton Capacities

Figure No.	Part Name	Parts Per Trolley	1/8 Ton	1/4 Ton	1/2 Ton	1 1/2 Ton	2 1/2 Ton
48	Name Plate C	1	MR2SHM01S9A7	MR2SHM03S9A7	MR2SHM05S9A7	MR2SHM15S9A7	MR2SHM25S9A7

9.1 Electric Parts – 1/8 to 5 Ton (Dual Speed)

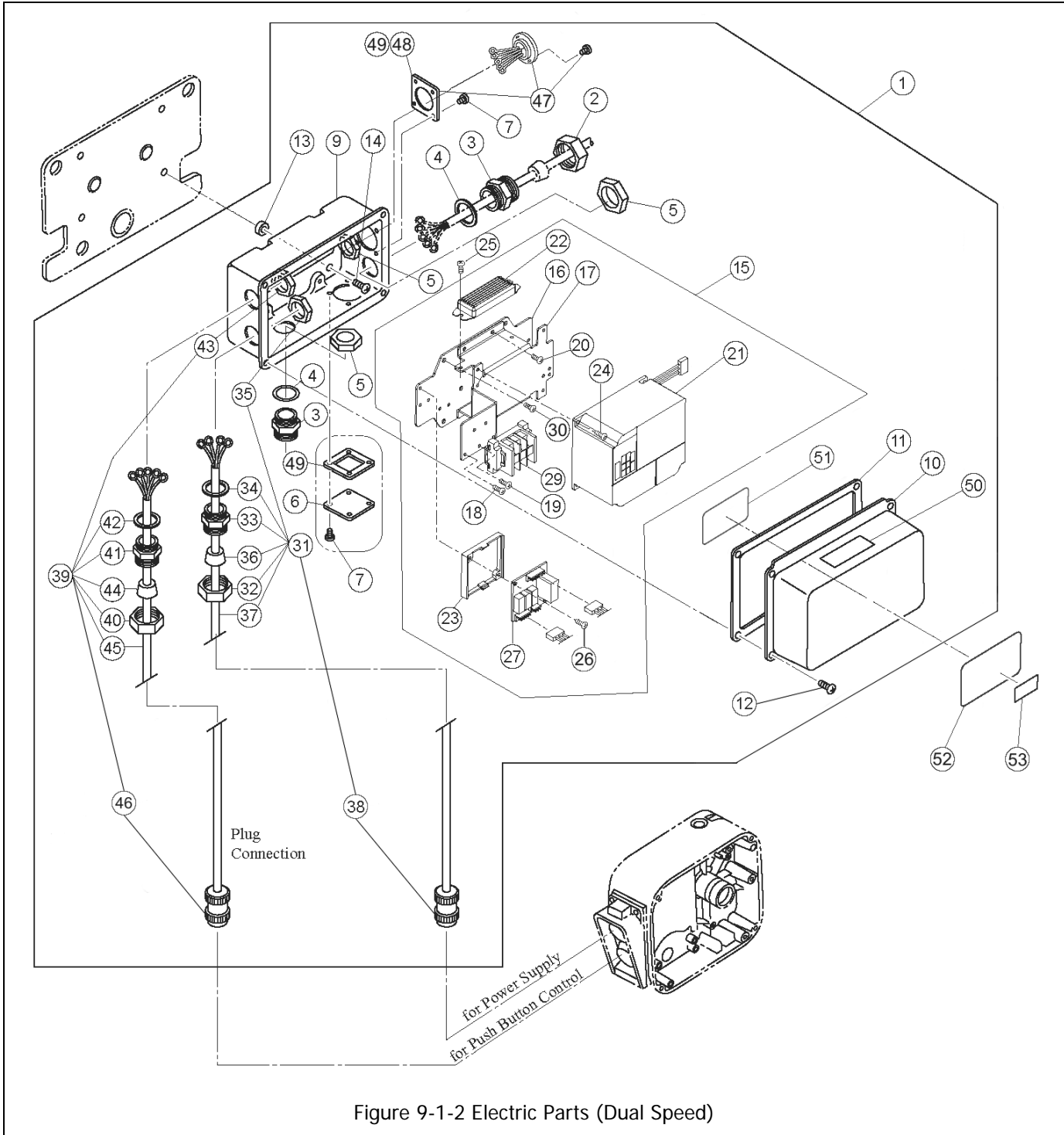

Figure 9-1-2 Electric Parts (Dual Speed)

9.1 Electric Parts– 1/8 to 5 Ton (Dual Speed)

Figure No.	Part Name	Parts Per Trolley		1 Ton	2 Ton	3 Ton	5 Ton
		2V	4V				
1	Connection Box Assembly	2V	1	7013101	7013102		7013103
		4V		7013104	7013105		7013106
2	Holder A		1		ECP5924AA		
3	Holder B		2		ECP5924AB		
4	Packing		2		ECP5924AC		
5	Holder Nut		2		ECP5924AD		
6	Cord Cover		1		E6F630010S		
7	Machine Screw With Spring Washer		8		MS554010		
9	Connection Box		1		MR1DS9401		
10	Connection Box Cover		1		MR1DS9411		
11	Connection Box Packing		1		MR1DS9421		
12	Machine Screw With Spring Washer		4		MS554010		
13	Spacer		4		MS517010		
14	Machine Screw With Spring Washer		4		MS551010		
15	Complete Plate Assembly	2V	1	MR2IHE10R1A5	MR2IHE20R1A5		MR2IHE50R1A5
		4V		MR2IHN10R1A5	MR2IHN20R1A5		MR2IHN50R1A5
16	Plate		1		MR2DI9441		
17	Plate B		1		MR2DI9443		
18	Machine Screw With Spring Washer		3		MS555010		
19	Machine Screw With Washers		2		J1AW24000808		
20	Machine Screw With Spring Washer		4		MS555010		
21	VFD Assembly	2V	1		INV604E31		INV60FE31
		4V			INV604N31		INV60FN31
22	Braking Resistor	2V	1		INV904E34		INV90FE34
		4V			INV904Y34		INV90FY34
23	Board Support		1		ECP99BKAB		
24	Machine Screw With Spring Washer		2		MS555010		
25	Machine Screw With Washers		2		J1AW24000808		
26	Machine Screw With Spring Washer		2		MS5556010		
27	Interface Board		1		ECP91KB12		
29	Terminal 3P		1		ECP1403AA		
30	Machine Screw With Spring Washer		4		MS554010		
31	Power Supply Cable Assembly		1	MR2DS1759		MR2ES1759	
32	Holder A		1		ECP5924AA		
33	Holder B		1		ECP5924AB		
34	Packing		1		ECP5924AC		
35	Holder Nut		1		ECP5924AD		
36	Cable Packing		1	ECP6912AA		ECP6916AA	
37	S.O. Cord 4C		1	16/4		14/4	
38	4P Plug		1	ECP2304AD		ECP2304AF	
39	Control Cable Assembly		1	MR2D11768		MR2E11768	
40	Holder A		1		ECP5924AA		
41	Holder B		1		ECP5924AB		
42	Packing		1		ECP5924AC		
43	Holder Nut		1		ECP5924AD		
44	Cable Packing		1		ECP6916AA		
45	S.O. Cord 6C		1		16/6P		
46	8P Plug		1		ECP2108AC		
47	Socket 8P Assembly	2V	1		MR2DI1811		
		4V			MR2DI2811		
48	Plate P		1		ECP5924AH		
49	Cord Cover Packing		2		MS527010		
50	Warning Seal E (Electric Shock)		1		ER2CS9936		
51	Wiring Diagram		1		EWG3DD0H01		
52	Name Plate B		1		MR2SHM10S9A8		
53	Name Plate C		1	MR2SHM10S9A7	MR2SHM20S9A7	MR2SHM30S9A7	MR2SHM50S9A7

Name Plates for 1/8, 1/4, 1/2, 1 1/2 & 2 1/2 Ton Capacities

Figure No.	Part Name	Parts Per Trolley	1/8 Ton	1/4 Ton	1/2 Ton	1 1/2 Ton	2 1/2 Ton
53	Name Plate C	1	MR2SHM01S9A7	MR2SHM03S9A7	MR2SHM05S9A7	MR2SHM15S9A7	MR2SHM25S9A7

9.1 Electric Parts – 1/8 to 5 Ton (Direct Connection)

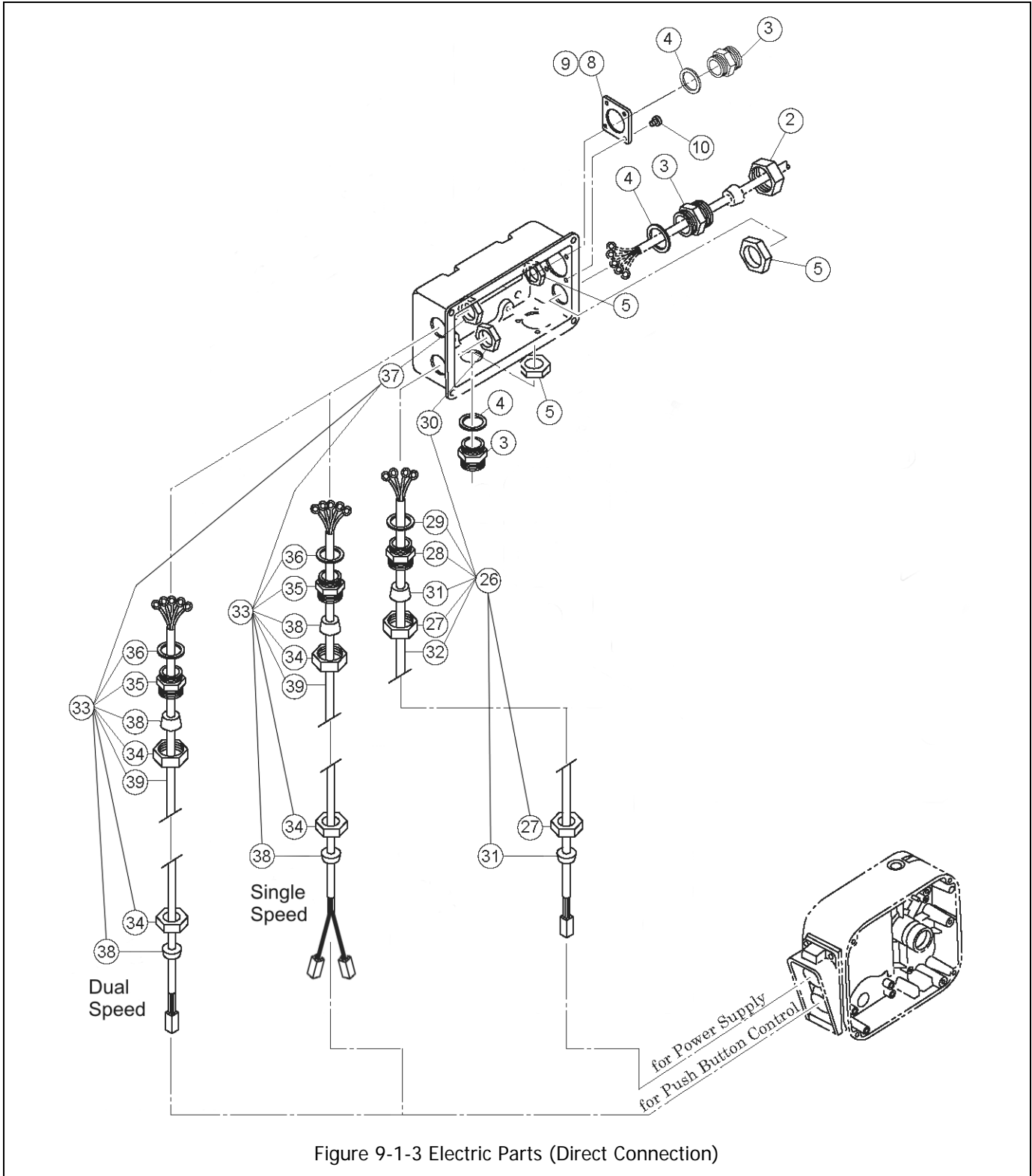

Figure 9-1-3 Electric Parts (Direct Connection)

9.1 Electric Parts– 1/8 to 5 Ton (Direct Connection)

Figure No.	Part Name	Parts Per Trolley	1 Ton	2 Ton	3 Ton	5 Ton
2	Holder A	1	ECP5924AA			
3	Holder B	3	ECP5924AB			
4	Packing	3	ECP5924AC			
5	Holder Nut	3	ECP5924AD			
8	Plate D	1	ECP5924AF			
9	Cord Cover Packing	2	MS527010			
10	Machine Screw With Spring Washer	4	MS554010			
26	Power Supply Cable Assembly	1	MR2DS2759	MR2ES2759		
27	Holder A	2	ECP5924AA			
28	Holder B	1	ECP5924AB			
29	Packing	1	ECP5924AC			
30	Holder Nut	1	ECP5924AD			
31	Cable Packing	2	ECP6912AA			
32	S.O. Cord 4C	1	16/4	14/4		
33	Control Cable Assembly	S	1	MR2DS2768	MR2ES2768	
		D		MR2DI2768	MR2EI2768	
34	Holder A	2	ECP5924AA			
35	Holder B	1	ECP5924AB			
36	Packing	1	ECP5924AC			
37	Holder Nut	1	ECP5924AD			
38	Cable Packing	2	ECP6916AA			
39	S.O. Cord 6C	1	16/6			

9.2 Pendant Parts – 1/8 to 5 Ton

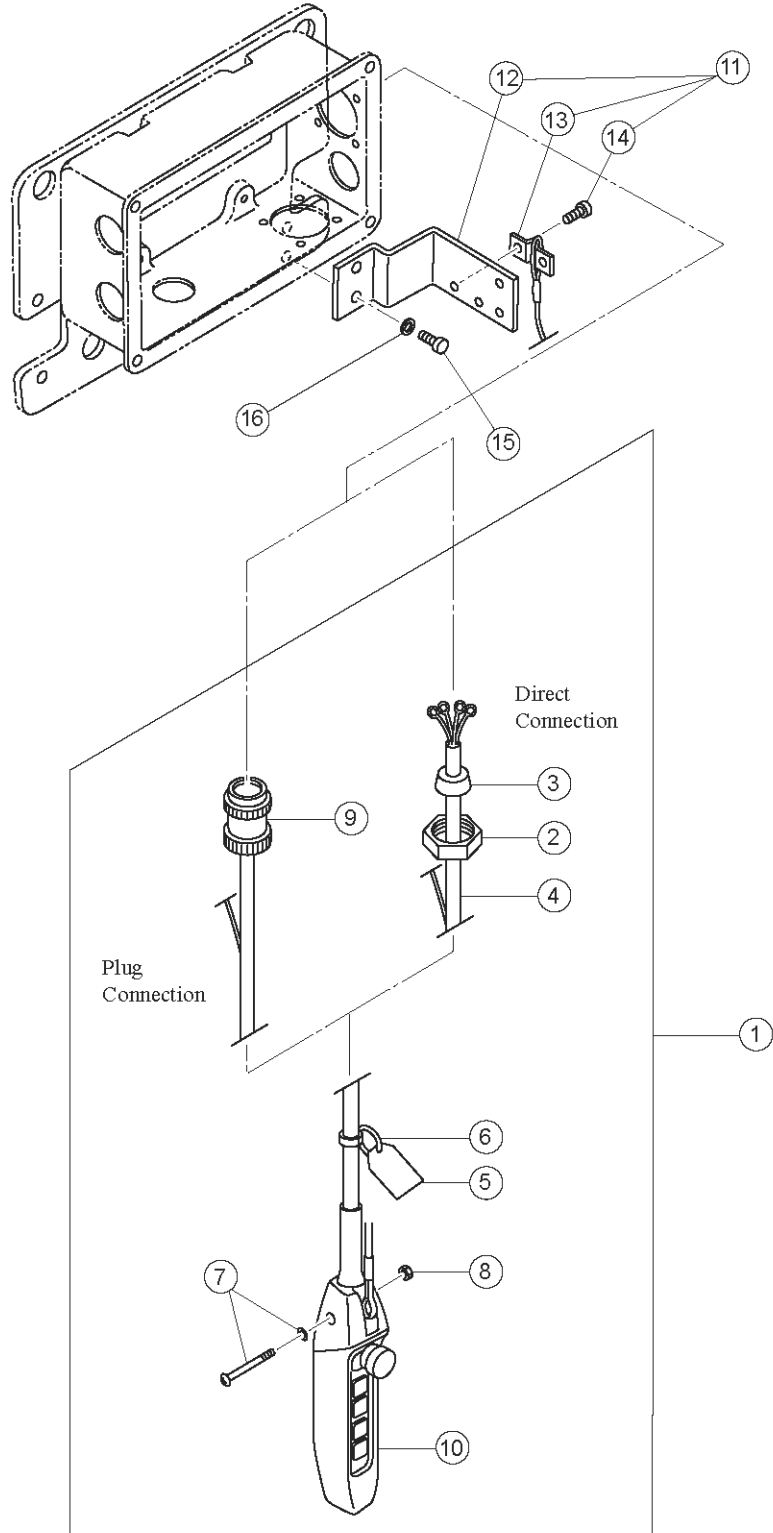

Figure 9-2-1 Pendant Parts

9.2 Pendant Parts – 1/8 to 5 Ton

Figure No.	Part Name	Parts Per Trolley		1 Ton	2 Ton	3 Ton	5 Ton
1	Push Button Cord 6C/7C/8C Complete Assembly	W	1	ZB1102A11000			
		X		ZB1202A11000			
		Y		ZB2102A11000			
		Z		ZB2202A11000			
2	Holder A	DC	1	ECP5924AA			
3	Cable Packing	DC	1	ECP6916AA			
4	Push Button Cord 6C	W	1	16/6P			
	Push Button Cord 8C	X, Y, Z		16/8P			
5	Warning Tag PB	1		WTAG7			
6	Tag Holder	1		E3S787003			
7	Machine Screw With Spring Washer	1		J1AP24002608			
8	Nut	1		9093414			
9	Plug 8P	W, PC	1	ECP2108AB			
		X, Y, Z, PC		ECP2108AD			
10	5 Push Button Switch Assembly	W	1	SWD2110AD			
		X		SWD2120AB			
		Y		SWD2210AB			
		Z		SWD2220AD			
11	Bar Holder Assembly	1		MR1DS1481			
12	Bar Holder	1		MR1DS9481			
13	Cord Strain Relief Stopper	1		E6L614010S			
14	Machine Screw With Spring Washer	2		E6F151003			
15	Socket Bolt	2		9091295			
16	Spring Washer	2		9012712			

9.3 Power Supply Parts – 1/8 to 5 Ton

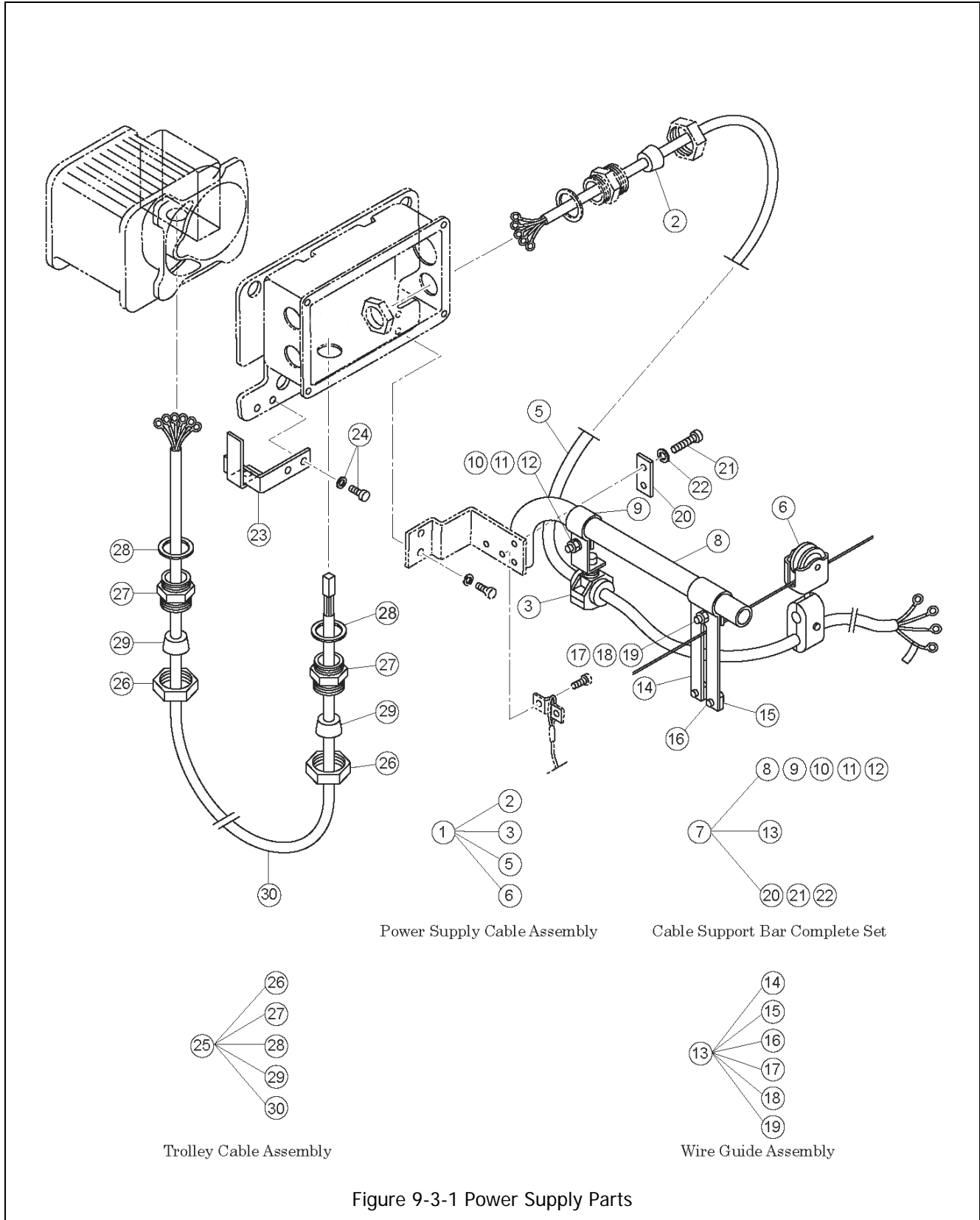

Figure 9-3-1 Power Supply Parts

9.3 Power Supply Parts – 1/8 to 5 Ton

Figure No.	Part Name	Parts Per Trolley	1 Ton	2 Ton	3 Ton	5 Ton
1	Power Supply Cable 4C Assembly	1	ZBZC12AH1100	ZBZC12BH1100		
	Cable Packing	1	ECP6914AA	ECP6916AA		
	Cable Support 14 Assembly	1	M3ES0101724			
	Power Supply Cable 4C	1	14/4	12/4		
	Cable Hanger 14 Assembly	A/R	ES1527003	MS1733020		
	Cable Support Bar Assembly	1	MR1DS1491			
8	Cable Support Bar	1	MR1DS9491			
9	Cable Support Arm	1	MR1DS9492			
10	Bolt	1	9093328			
11	Spring Lock Washer	1	9012711			
12	Nut	1	9093424			
13	Wire Guide Assembly	1	MR1DS1493			
14	Wire Guide	1	MR1DS9493			
15	Wire Stopper	1	MR1DS9496			
16	Machine Screw With Spring Washer	2	M6F554010			
17	Bolt	1	9093328			
18	Spring Lock Washer	1	9012711			
19	Nut	1	9093424			
20	Support Bar Holder (Plate)	1	MR1DS9501			
21	Bolt	2	9093329			
22	Spring Lock Washer	2	9012711			
23	Cable Hanger Pusher (Beam 75mm)	1	MR1DS9511			
	Cable Hanger Pusher (Beam 100-150mm)	1	MR1DS9512			
	Cable Hanger Pusher (Beam 125-175mm)	1				MR1GS9511
24	Socket Bolt With Spring Washer	2	J1BG11002828			
25	Trolley Cable 6C Assembly	1	MR2DS1793			
26	Holder A	2	ECP5924AA			
27	Holder B	2	ECP5924AB			
28	Packing	2	ECP5924AC			
29	Cable Packing	2	ECP6912AA			
30	Trolley Cable 6C	1	16/6			

*A/R = As Required, one for every 5 ft of power Supply Cable.

9.4 Side Plates and Suspension Parts – 1/8 to 5 Ton

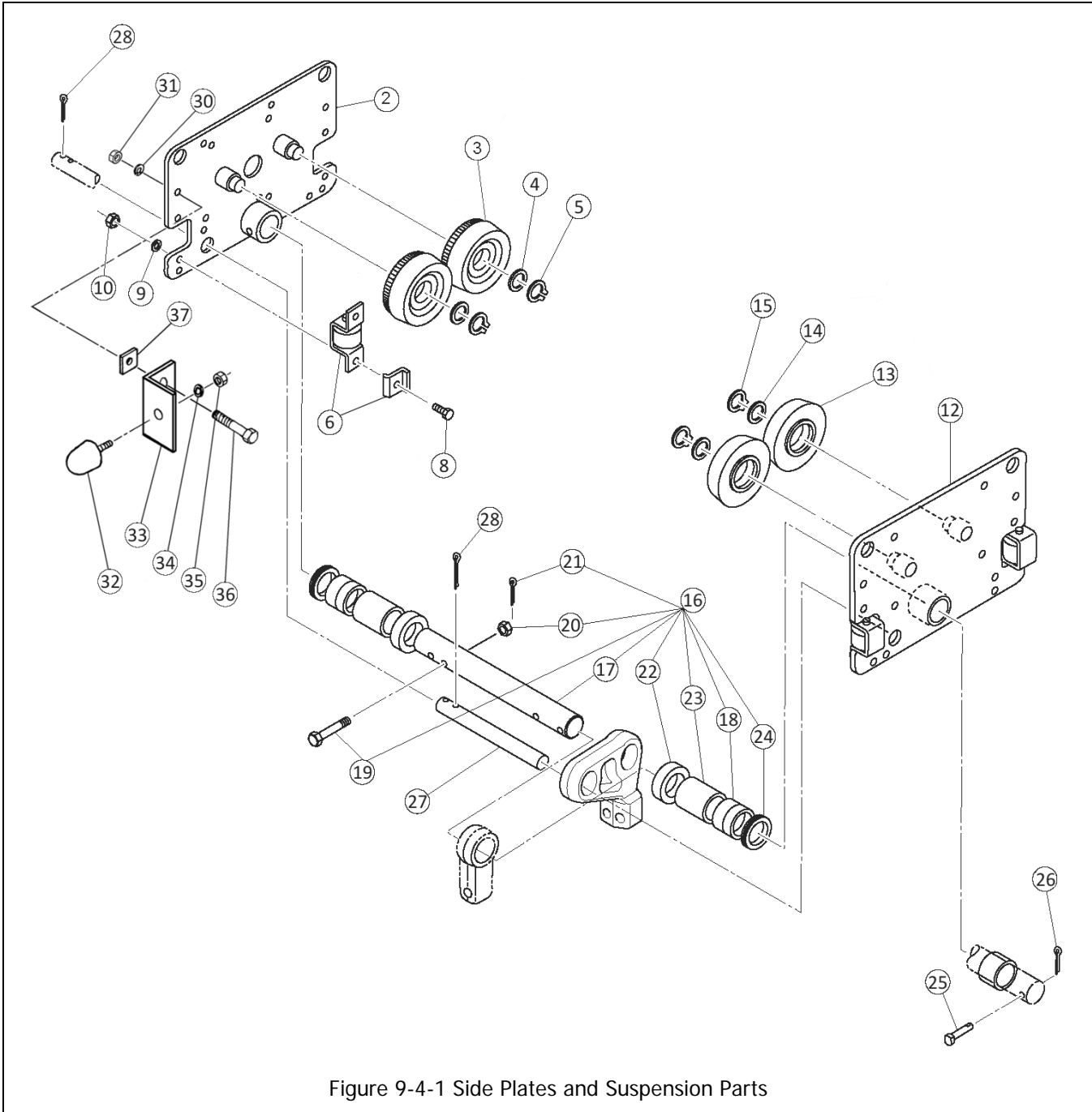

Figure 9-4-1 Side Plates and Suspension Parts

9.4 Side Plates and Suspension Parts– 1/8 to 5 Ton

Figure No.	Part Name	Parts Per Trolley	1 Ton	2 Ton	3 Ton	5 Ton
2	Side Plate G Assembly	1	MR1DS5201	MR1ES5201	MR1FS5201	MR1GS5201
3	Track Wheel G Assembly	2	MS1101010	MS1101020	MS1101030	MS1101050
4	Washer	2	MS104010	MS104020	MS104030	MS104050
5	Snap Ring	2	9047115	9047120	9047125	9047135
6	Side Roller Assembly	4	MR1DS1211	MR1ES1211		MR1GS1211
8	Bolt	4	9093329	9093351		90933116
9	Spring Lock Washer	4	9012711	9012712		9012715
10	Nut	4	9093424	9093427		9093439
12	Side Plate S Assembly	1	MR1DS5202	MR1ES5202	MR1FS5202	MR1GS5202
13	Track Wheel S Assembly	2	MS1102010	MS1102020	MS1102030	MS1102050
14	Washer	2	MS104010	MS104020	MS104030	MS104050
15	Snap Ring	2	9047115	9047120	9047125	9047135
16	Suspension Shaft Assembly	1	MR1DS1111	MR1ES1111	MR1FS1111	MR1GS1111
17	Suspension Shaft	1	MSF115010	MSF115020	MR1FS9101	MR1GS9101
18	Thick Spacer	3	MSF116010	T7G116030	MSF116030	MSF116050
19	Bolt	1	MS161010	MS161020	T3P153050	MS161050
20	Slotted Nut	1	T3P154020		MS162030	
21	Split Pin	1	90094145		90094165	
22	Thick Spacer L	2	MR1DS9110	MR1ES9110	MR1FS9110	MR1GS9110
24	Thin Spacer	8	MSF117010	MSF117020	MSF117030	MSF117050
25	Shaft Stopper	1	T6G156020	MS164020	MS164030	MS164050
26	Split Pin	1	9009432		9009433	
27	Fixing Shaft	1	MR1DS9131	MR1ES9131	MR1FS9131	MR1GS9131
28	Split Pin	2	9009446		9009448	
30	Spring Washer	8	9012711	9012712		9012715
31	Nut	8	9093424	9093427		9093433
32	Bumper	4	MR1DS9631		MR1FS9631	
33	Bumper Bracket	4	MR1DS9634	MR1ES9634		MR1GS9634
34	Spring Washer	4	9012711			
35	Nut	4	9093424			
36	Bolt	8	9093330	9093352		90933118
37	Square Spacer	4	MS006010	MS006020		MS006050

Extended Suspension Shaft Assemblies

Figure No.	Part Name	Parts Per Trolley	1 Ton	2 Ton	3 Ton	5 Ton
16	Suspension Shaft Assembly	1	MR1DS1112	MR1ES1112	MR1FS1112	MR1GS1112
17	Suspension Shaft	1	MSF181010	MSF181020	MR1FS9121	MR1GS9121
18	Thick Spacer	9 (13)	MSF116010	T7G116030	MSF116030	MSF116050
19	Bolt	1	MS161010	MS161020	MS161030	MS161050
20	Slotted Nut	1	T3P154020		MS162030	
21	Split Pin	1	90094145		90094165	
22	Thick Spacer L	2	MR1DS9110	MR1ES9110	MR1FS9110	MR1GS9110
23	Fixing Spacer	2	MSF182010	MSF182020	MSF182030	
24	Thin Spacer	8	MSF117010	MSF117020	MSF117030	MSF117050
27	Fixing Shaft	1	MR1DS9141	MR1ES9141	MR1FS9141	MR1GS9141
28	Split Pin	2	9009446		9009448	

*Quantity in parentheses is for 5 Ton Trolley.

9.5 Motor Parts – 1/8 to 5 Ton

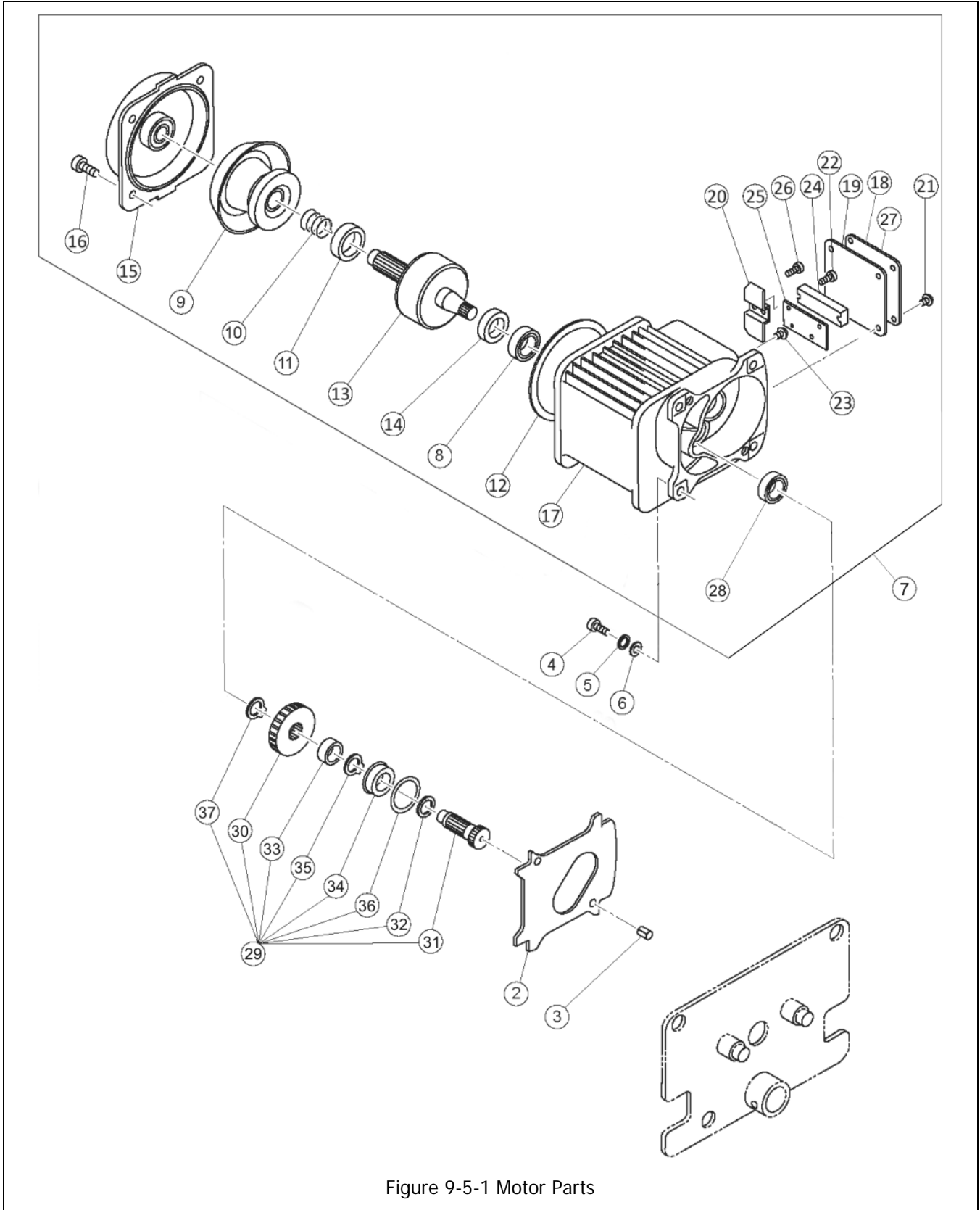

Figure 9-5-1 Motor Parts

9.5 Motor Parts – 1/8 to 5 Ton

Figure No.	Part Name	Parts Per Trolley	1 Ton	2 Ton	3 Ton	5 Ton
2	Gear Box Packing	1	MR1DS9248			
3	Set Pin	2	MR1DS9249			
4	Bolt	4	9093328			
5	Spring Lock Washer	4	9012711			
6	Washer	4	9012513			
7	Motor Assembly	1	7018401			7018402
8	Ball Bearing	1	9001004			
9	Brake Drum Assembly	1	MR1DS5261			
10	Brake Spring	1	MS304010			
11	Bumper	1	MR1DS9265			
12	Guard	1	MR1DS9281			
13	Motor Shaft With Rotor	1	MR1DS5291			MR1GS5291
14	Oil Seal	1	MR1DS9293			
15	Motor Cover Assembly	1	MR1DS1301			
16	Socket Bolt	4	90912134			
17	Motor Frame With Stator	1	B1SHM10S5A2			B1SHM50S5A2
18	Terminal Cover	1	MR1DS9324			MR1GS9324
19	Terminal Cover Packing	1	MR1DS9325			MR1GS9325
20	Coil Cover	1	MR1DS9326			
21	Machine Screw With Spring Washer	4	MS554010			
22	Machine Screw With Spring Washer	2	MS556010			
23	Machine Screw With Spring Washer	1	MS555010			
24	Terminal 6P	1	ECP1306AB			
25	Terminal Plate Holder	1	MR1DS9855			
26	Flat Head Tapping Screw	2	9096529			
27	Motor Data Plate	1	IMNBH04VT			IMNBH0FVT
28	Ball Bearing	1	E2D238125			

Figure No.	Part Name	Parts Per Trolley	1 Ton S/SD	1 Ton L/LD	2 Ton S/SD	2 Ton L/LD	3 Ton S/SD	3 Ton L/LD	5 Ton S/SD	5 Ton L/LD
29	Gear Assembly	1	MR1DS1241	MR1DL1241	MR1ES1241	MR1EL1241	MR1ES1241	MR1EL1241	MR1GS1241	MR1GL1241
30	Gear #2	1	MR1DS9241	MR1DL9241	MR1DS9241	MR1DL9241	MR1DS9241	MR1DL9241	MR1DS9241	MR1DL9241
31	Gear #3	1	MR1DS9242		MR1ES9242		MR1GS9242			
32	O Ring	1	9013316							
33	Spacer	1	MR1DS9244							
34	Ball Bearing	1	9001211							
35	Snap Ring	2	9047120							
36	O Ring	1	MR1DS9254							
37	Snap Ring	1	9047120							

9.6 Motor Parts – 8 to 20 Ton

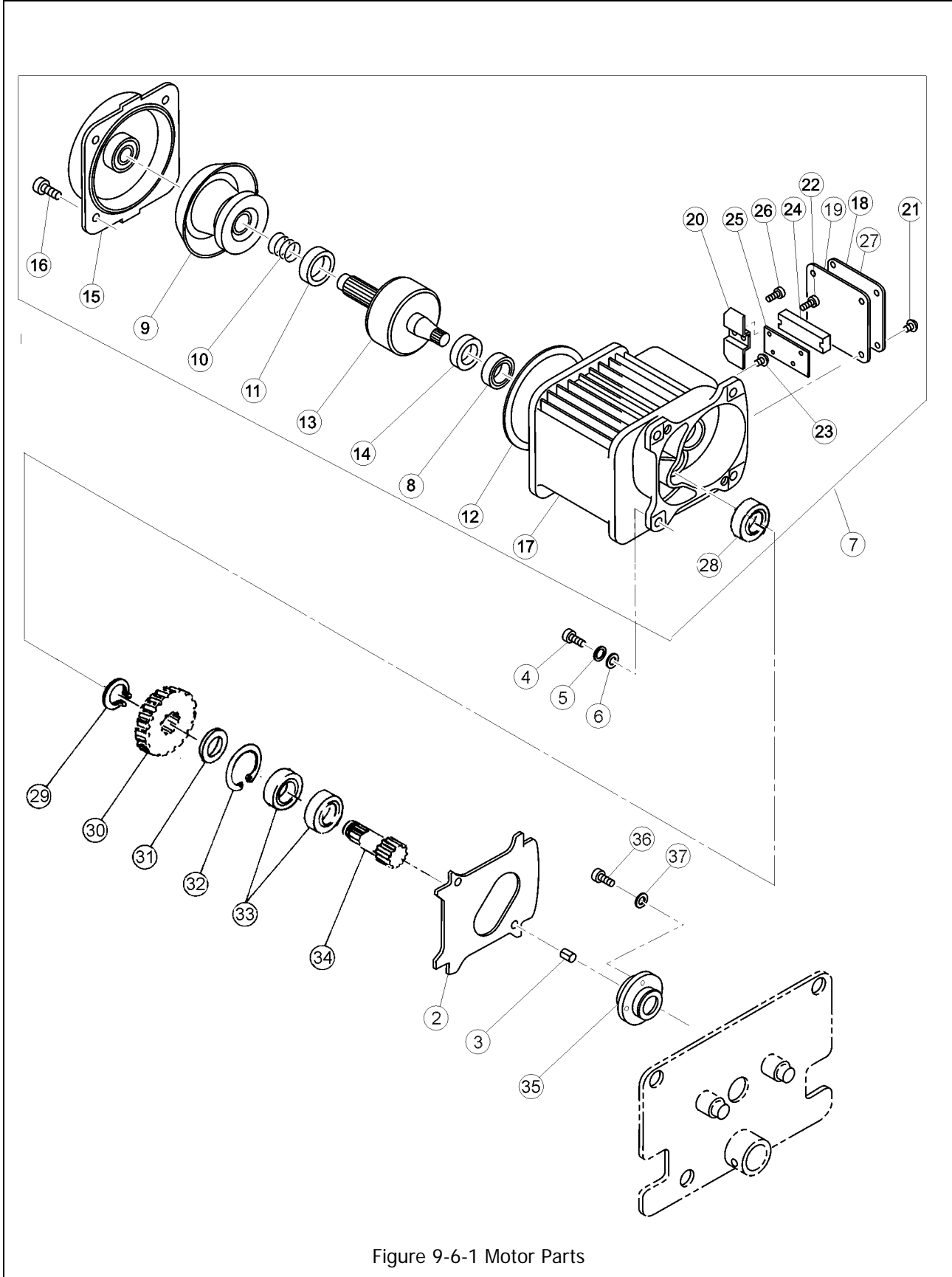

Figure 9-6-1 Motor Parts

9.6 Motor Parts – 8 to 20 Ton

Figure No.	Part Name	Parts Per Trolley	8 Ton	10 Ton	15 Ton	20 Ton
2	Gear Frame Packing	1 (2)			MR1IS9248	
3	Set Pin	2 (4)			MR1DS9249	
4	Bolt	4 (8)			9093328	
5	Spring Lock Washer	4 (8)			9012711	
6	Washer	4 (8)			9012513	
7	Motor Assembly	1 (2)			7018402	
8	Ball Bearing	1 (2)			9001004	
9	Brake Drum Assembly	1 (2)			MR1DS5261	
10	Brake Spring	1 (2)			MS304010	
11	Bumper	1 (2)			MR1DS9265	
12	Guard	1 (2)			MR1DS9281	
13	Motor Shaft With Rotor	1 (2)			MR1DS5291	
14	Oil Seal	1 (2)			MR1DS9293	
15	Motor Cover Assembly	1 (2)			MR1DS1301	
16	Socket Bolt	4 (8)			9091272	
17	Motor Frame With Stator	1 (2)			B1SHM50S5A2	
18	Terminal Cover	1 (2)			MR1DS9324	
19	Terminal Cover Packing	1 (2)			MR1DS9325	
20	Coil Cover	1 (2)			MR1DS9326	
21	Machine Screw With Spring Washer	4 (8)			MS554010	
22	Machine Screw With Spring Washer	2 (4)			MS556010	
23	Machine Screw With Spring Washer	1 (2)			MS555010	
24	Terminal 6P	1 (2)			ECP1306AB	
25	Terminal Plate Holder	1 (2)			MR1DS9855	
26	Flat Head tapping Screw	2 (4)			9096529	
27	Motor Data Plate	1 (2)			IMNBH0FVT	
28	Ball Bearing	1 (2)			E2D238125	
29	Snap Ring	1 (2)			9047125	
30	Gear #2	1 (2)			MR1IS9241	
31	Spacer	1 (2)			MR1IS9244	
32	Snap Ring	1 (2)			9047252	
33	Ball Bearings	2 (4)			9000605	
34	Gear #3	1 (2)			MR1IS9242	
35	Bearing Holder	1 (2)			MR1IS9257	
36	Socket Bolt	4 (8)			9091252	
37	Spring Lock Washer	4 (8)			9012709	

*Quantity in parentheses is for 15 Ton AND 20 Ton Trolley.

9.7 Side Plates and Suspension Parts – 8 to 20 Ton

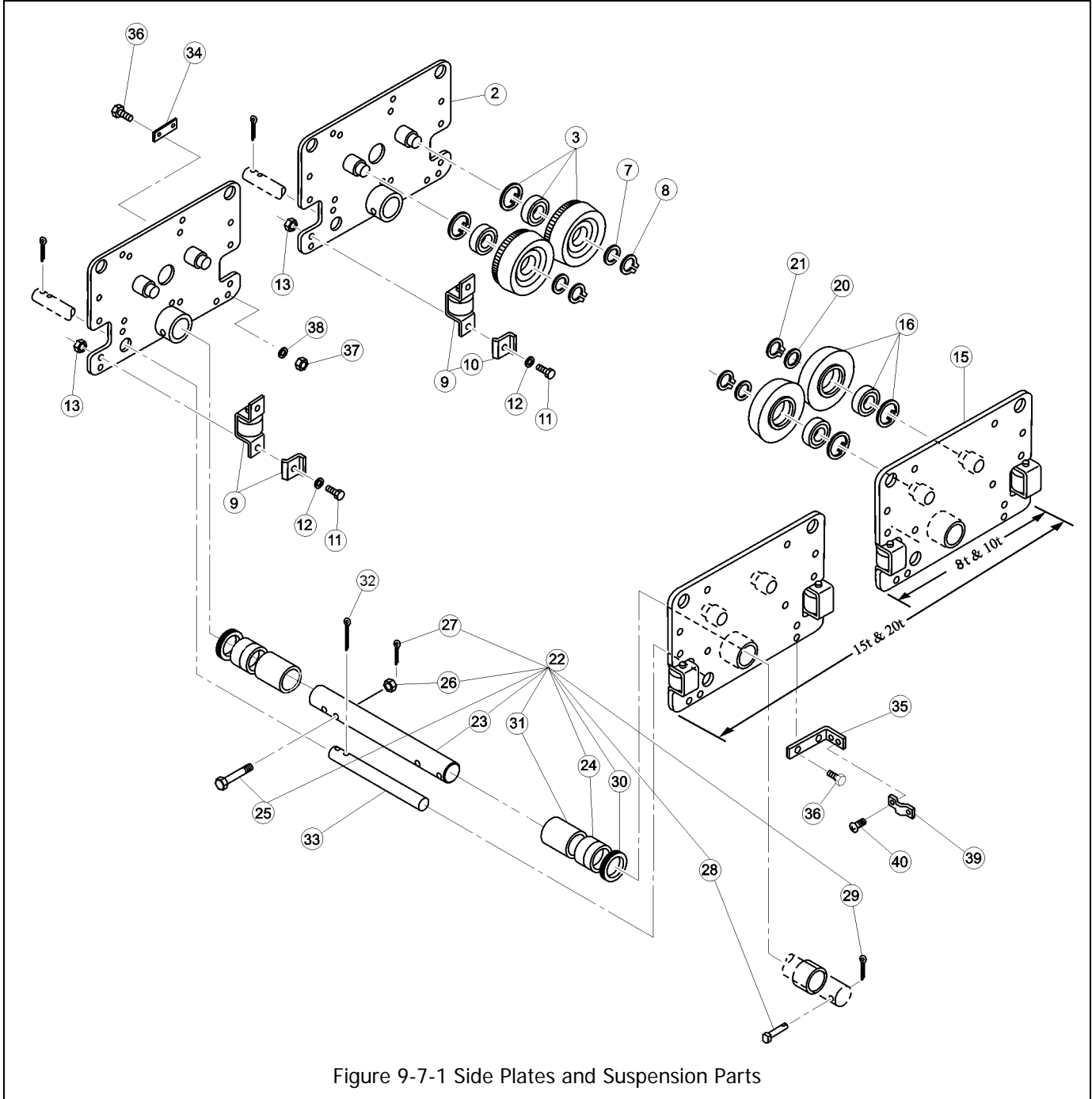

Figure 9-7-1 Side Plates and Suspension Parts

9.7 Side Plates and Suspension Parts – 8 to 20 Ton

Figure No.	Part Name	Parts Per Trolley	8 Ton	10 Ton	15 Ton	20 Ton
2	Side Plate G Assembly	1 (2)			MR1IS5201	
3	Track Wheel G Assembly	2 (4)			MS1101075	
7	Washer	2 (4)			MS104075	
8	Snap Ring	2 (4)			9047145	
9	Side Roller Complete Assembly	4 (8)			MR1GS1211	
11	Bolt	4 (8)			90933116	
12	Spring Lock Washer	4 (8)			9012715	
13	Nut	4 (8)			9093439	
15	Side Plate S Assembly	1 (2)			MR1IS5202	
16	Track Wheel S Assembly	2 (4)			MS1102075	
20	Washer	2 (4)			MS104075	
21	Snap Ring	2 (4)			9047145	
22	Suspension Shaft Complete Assembly	1 (2)			M6SS100S1115	
23	Suspension Shaft	1 (2)			MS115075	
24	Thick Spacer	6 (12)			MS117075	
25	Bolt	1 (2)			MS161100	
26	Slotted Nut	1 (2)			ES088020L	
27	Split Pin	1 (2)			9009436	
28	Shaft Stopper	1 (2)			MS164075	
29	Split Pin	1 (2)			9009435	
30	Thin Spacer	8 (16)			MS116075	
32	Split Pin	2	9009448			
33	Fixing Shaft	1	E6S010075			
34	Connection Plate	1			MS105150	
35	Connection Plate S	1			MR1JS9225	
36	Bolt	4			MS106150	
37	Nut	4			9093433	
38	Spring Lock Washer	4			9012713	
39	Cord Chain Stopper	1			E6L614010S	
40	Machine Screw With Spring Washer	2			J1AP26000808	

Extended Suspension Shaft Assemblies

Figure No.	Part Name	Parts Per Trolley	8 Ton	10 Ton	15 Ton	20 Ton
22	Suspension Shaft Assembly	1 (2)			M6SS1001118	
23	Suspension Shaft	1 (2)			M6SE100S9181	
24	Thick Spacer	7 (14)			MS117075	
25	Bolt	1 (2)			MS161100	
26	Slotted Nut	1 (2)			ES088020L	
27	Split Pin	1 (2)			9009436	
28	Shaft Stopper	1 (2)			MS164075	
29	Split Pin	1 (2)			9009435	
30	Thin Spacer	8 (16)			MS116075	
31	Fixing Spacer	2 (4)			M6SE100S9182	
32	Split Pin	2	9009448			
33	Fixing Shaft	1	E3S018075			

*Quantity in parentheses is for 15 Ton and 20 Ton Trolley.

9.8 Electric Parts – 8 to 20 Ton

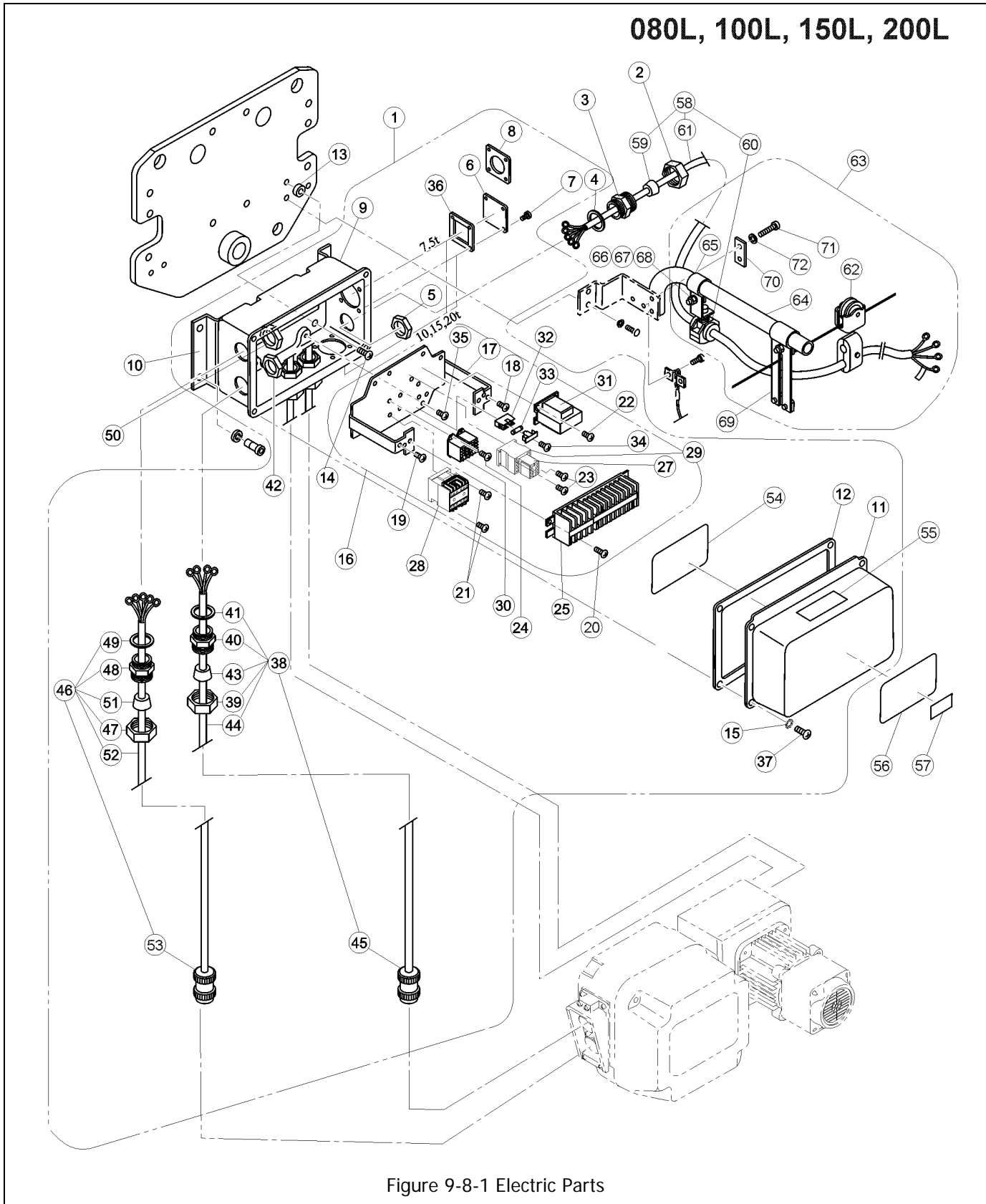

Figure 9-8-1 Electric Parts

9.8 Electric Parts – 8 to 20 Ton

Figure No.	Part Name	Parts Per Trolley	8 Ton	10 Ton (L/LD Hoist)	10 Ton (S/SD Hoist)	15 Ton	20 Ton	
1	Connection Box Complete Assembly	1	7016501		7016502	7016503		
2	Holder A	1					ECP5924AA	
3	Holder B	1					ECP5924AB	
4	Packing	1					ECP5924AC	
5	Holder Nut	1					ECP5924AD	
6	Cord Cover	1	E6F630010S					
7	Machine Screw With Spring Washer	4					MS554010	
8	Plate D	1					ECP5924AF	
9	Connection Box	1					MR1DS9401	
10	Connection Box Holder	1					MR1HS9405	
11	Connection Box Cover	1					MR1DS9411	
12	Connection Box Packing	1					MR1DS9421	
13	Spacer	4					MS517010	
14	Machine Screw With Spring Washer	4					J1AP28001414	
15	Toothed Lock Washer	4					9679708	
16	Plate Complete Assembly	1	MR2RHM75M1A5		MR2RHM1QM1A5			
17	Plate Assembly	1	MR2DS5445		MR2IS5445			
18	Machine Screw With Spring Washer	1					MS554010	
19	Machine Screw With Spring Washer	5					MS555010	
20	Machine Screw With Spring Washer	2	J1AW24001212		MS554010			
21	Machine Screw With Spring Washer	2					MS556010	
22	Machine Screw With Spring Washer	2					MS555010	
23	Machine Screw With Spring Washer	2					J1AP24001212	
24	Machine Screw With Spring Washer	4					J1AW23000808	
25	Terminal 10P	1	ECP1416AA		ECP1610AA			
27	Auxiliary Contactor	1					MGC92409A	
28	Contactor	1	MGC22306B		MGC23306C			
29	Contactor	1					MGC12306B	
30	Relay	1					MGC42C26A	
31	Transformer	1					TRF72V613	
32	Fuse Holder	1					ECP92FZAA	
33	Fuse	1					ECP91FZ01	
34	Machine Screw With Spring Washer	1					E2D667125	
35	Machine Screw With Spring Washer	4					MS554010	
36	Cord Cover Packing	1					MS527010	
37	Machine Screw With Spring Washer	4					MS554010	
38	Relay Cable 4C Assembly	1 (2)	MR2HS1759		MR2IS1759	MR2JS1759		
39	Holder A	1 (2)					ECP5924AA	
40	Holder B	1 (2)					ECP5924AB	
41	Packing	1 (2)					ECP5924AC	
42	Holder Nut	1 (2)					ECP5924AD	
43	Cable Packing	1 (2)					ECP6916AA	
44	Relay Cable 4C	1 (2)					14/4	
45	Plug 4P	1 (2)					ECP2304AF	
46	Relay Cable 4/5C Assembly	W	1 (2)		MR2HS1768	MR2IS1768	MR2JS1768	
		Y				MR2IS3768	MR2JS3768	
47	Holder A	1 (2)					ECP5924AA	
48	Holder B	1 (2)					ECP5924AB	
49	Packing	1 (2)					ECP5924AC	
50	Holder Nut	1 (2)					ECP5924AD	
51	Cable Packing	1 (2)					ECP6916AA	
52	Relay Cable 4/6C	W	1 (2)		16/6P	16/4P		
		Y				16/6P		
53	Plug 8P	1 (2)					ECP2108AC	
54	Wiring Diagram	W	1 (2)		EWG3210H01	EWG3210H11	EWG3210H21	
		Y			EWG3E10H01	EWG3E10H11	EWG3E10H21	
55	Warning Seal E (Electric Shock)	1 (2)					ER2CS9936	
56	Name Plate B	1 (2)					MR2SHM10S9A8	
57	Name Plate C	1 (2)	MR2SHM75S9A7	MR2SHM10S9A7	MR2SHM1PS9A7	MR2SHM2QS9A7		
58	Power Supply Cable 4C Assembly	1	ZBZC12AH1000		ZBZC12BH2000			
59	Cable Packing	1					ECP6918AA	
60	Cable Support 16/19 Assembly	1	M3ES0101724				ECP5900CA	
61	Power Supply Cable 4C	1	12/4				10/4	
62	Cable Hanger 15 Assembly	n					MS1733020	
63	Cable Support Bar Complete Assembly	1	MR1DS1491		MR1DS1491 (2 required)			
64	Cable Support Bar	1					MR1DS949	
65	Cable Support Arm	1					MR1DS949	
66	Bolt	2					9093328	
67	Spring Lock Washer	2					9012711	
68	Nut	2					9093424	
69	Wire Guide Assembly	1					MR1DS149	
70	Support Bar Holder (Plate)	1					MR1DS950	
71	Bolt	2					9093329	
72	Spring Lock Washer	2					9012711	

*Quantity in parentheses is for 15 Ton and 20 Ton Trolley.

9.9 Pendant Parts – 8 to 20 Ton

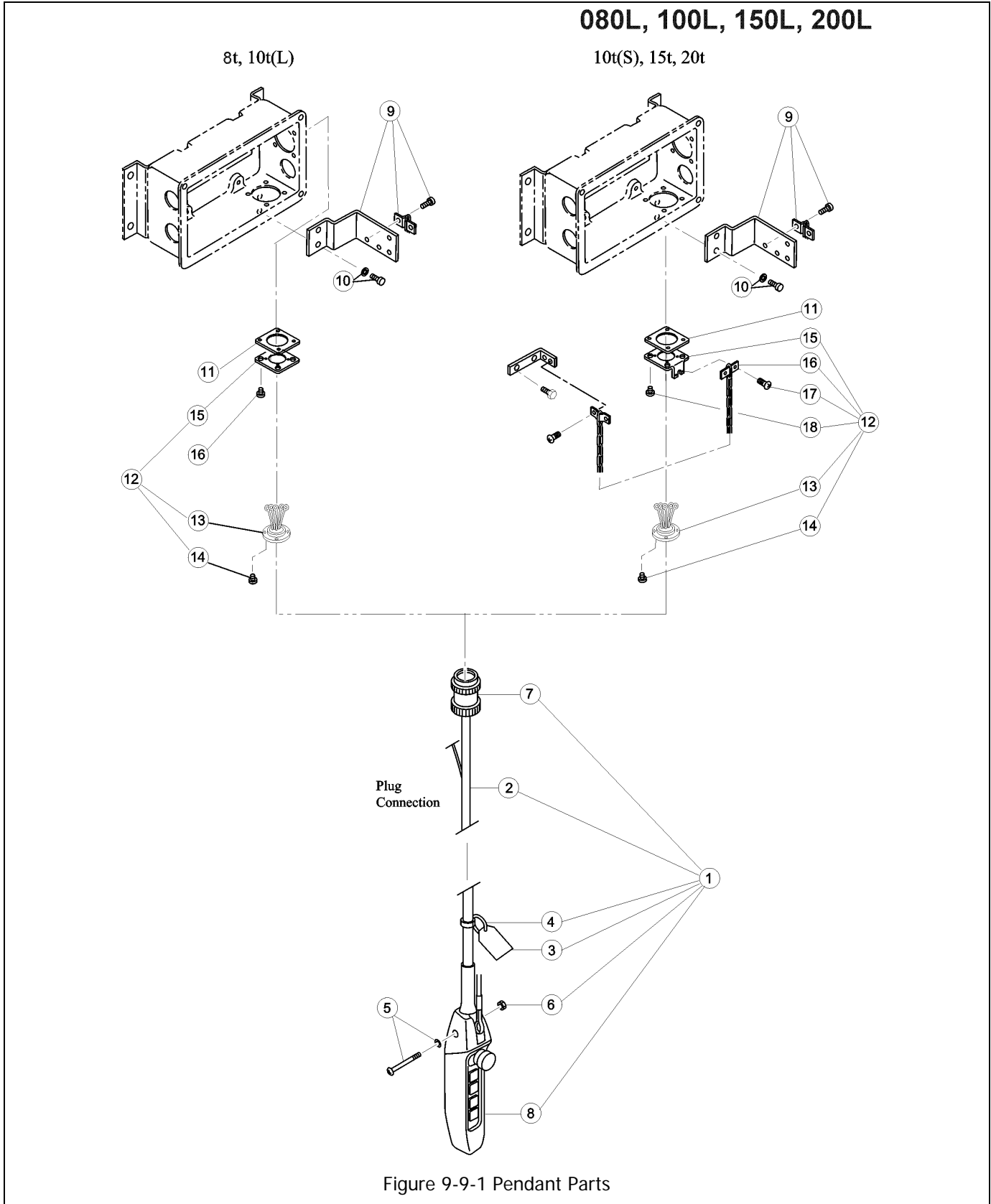

9.9 Pendant Parts – 8 to 20 Ton

Figure No.	Part Name	Parts Per Trolley		8 Ton
1	Push Button Cord 6C/7C/8C Complete Assembly	W	1	ZB1102AI1000
		Y		ZB2102AI1000
2	Push Button Cord 6C	W	1	16/6P
	Push Button Cord 8C	Y		16/8P
3	Warning Tag PB	1		SWD9013AE
4	Tag Holder	1		E3S787003
5	Machine Screw With Spring Washer	1		J1AP24002608
6	Nut	1		9093414
7	Plug 8P	W	1	ECP2108AB
		Y		ECP2108AD
8	5 Push Button Switch Assembly	W	1	SWD2110AD
		Y		SWD2210AB
9	Bar Holder Assembly	1		MR1DS1481
10	Socket Bolt	2		J1BG11002828
11	Cord Cover Packing	1		MS527010
12	Socket 8P Complete Assembly	1		MR2DS2811
13	Socket 8P Assembly	1		MR2DS5811
14	Tapping Flat Head machine Screw	4		E3S658015
15	Plate P	1		ECP5924AH
16	Machine Screw With Spring Washer	4		MS554010

Figure No.	Part Name	Parts Per Trolley		10 Ton	15 Ton	20 Ton
1	Push Button Cord 6C/7C/8C Complete Assembly	W	1	ZB1102AI1000		
		Y		ZB2102AI1000		
2	Push Button Cord 6C	W	1	16/6P		
		Y		16/8P		
3	Warning Tag PB	1		SWD9013AE		
4	Tag Holder	1		E3S787003		
5	Machine Screw With Spring Washer	1		J1AP24002608		
6	Nut	1		9093414		
7	Plug 8P	W	1	ECP2108AB		
		Y		ECP2108AD		
8	5 Push Button Switch Assembly	W	1	SWD2110AD		
		Y		SWD2210AB		
9	Bar Holder Assembly	1		MR1DS1481		
10	Socket Bolt	2		J1BG11002828		
11	Cord Cover Packing	1		MS527010		
12	Socket 8P Complete Assembly	1		MR2IS1811		
13	Socket 8P Assembly	1		MR2IS5811		
14	Tapping Flat Head machine Screw	4		E3S658015		
15	Socket Holder	1		MS529010		
16	Cord Chain Stopper	1		E6L614010S		
17	Machine Screw With Spring Washer	2		MS554010		
18	Machine Screw With Spring Washer	4		MS554010		

9.10 Optional Parts – 8 Ton

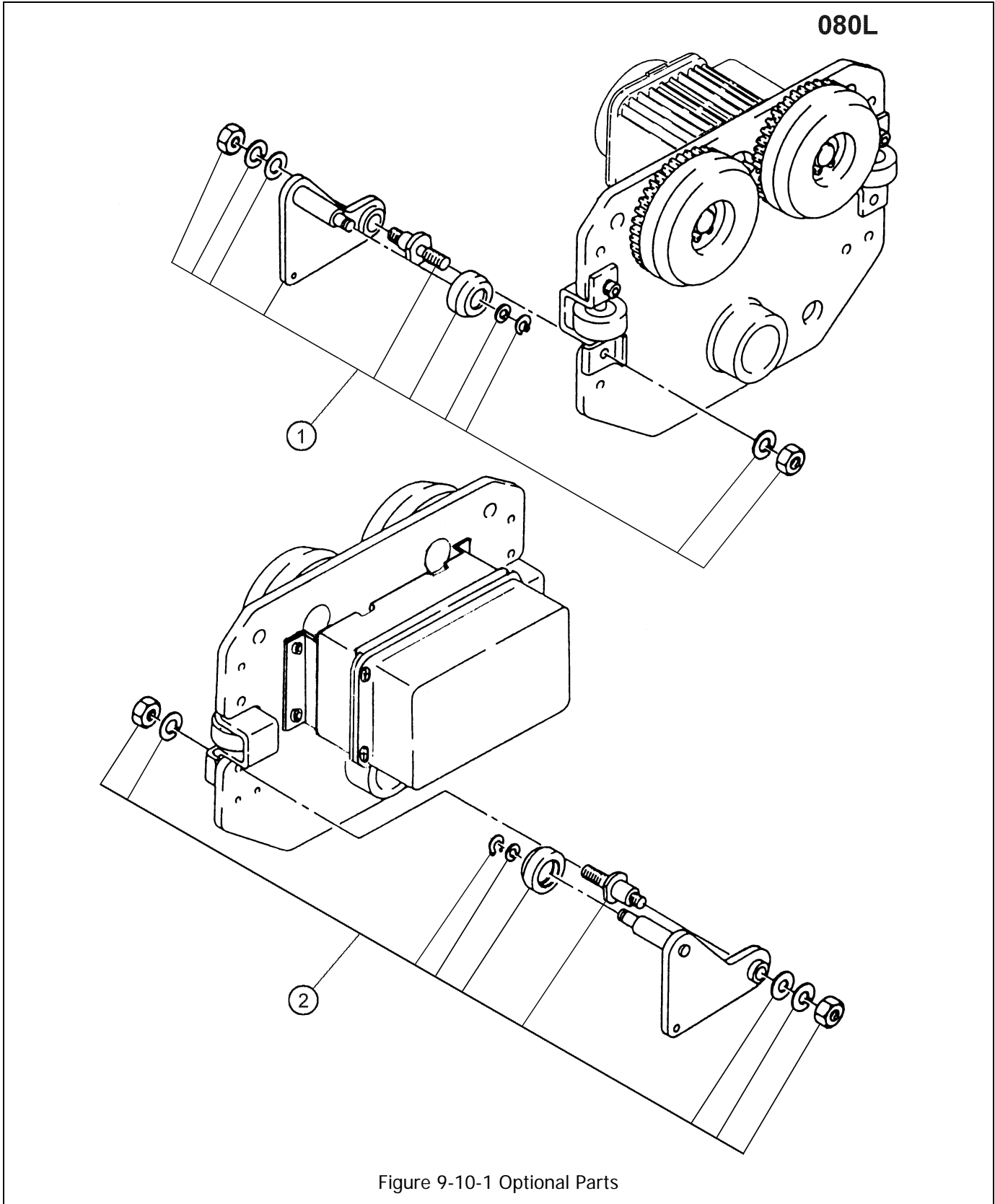

9.10 Optional Parts – 8 to 20 Ton

Figure No.	Part Name	Parts Per Trolley	8 Ton
1	Hanger Plate A Assembly	1	MS1401075
2	Hanger Plate B Assembly	1	MS1402075



www.harringtonhoists.com

Harrington Hoists, Inc.
401 West End Avenue
Manheim, PA 17545-1703
Phone: 717-665-2000
Toll Free: 800-233-3010
Fax: 717-665-2861

Harrington Hoists – Western Division
2341 Pomona Rd. #103
Corona, CA 92880-6973
Phone: 951-279-7100
Toll Free: 800-317-7111
Fax: 951-279-7500

MR20M